



WORKSHOP MANUAL

TRACTOR

B1550 • B1550HST
B1750 • B1750HST
B2150 • B2150HST

Kubota

TO THE READER

This Workshop Manual has been prepared to provide servicing personnel with information on the mechanism, service and maintenance of KUBOTA Tractors B1550, B1750, B2150, B1550HST, B1750HST and B2150HST. It is divided into two parts, "Mechanism" and "Disassembling and Servicing"

■ Mechanism

Information on the construction and function are included for each tractor section. This part should be understood before proceeding with troubleshooting, disassembling and servicing.

■ Servicing

Under the heading "General" comes general precautions, check and maintenance and special tools. For each section, there are troubleshooting, servicing specification lists, checking and adjusting, disassembling and assembling, and servicing which cover procedures, precautions, factory specifications and allowable limits.

All information, illustrations and specifications contained in this manual are based on the latest production information available at the time of publication.

The right is reserved to make changes in all information at any time without notice.

Aug. '88

© KUBOTA Corporation 1993

SPECIFICATIONS

Model		B1550 2WD				B1550 4WD			
Engine gross power		12.7 kW (17 HP)*							
PTO power		10.5 kW (14 HP)*							
Engine	Model	D850-58							
	Type	Vertical, water-cooled, 4-cycle diesel							
	No. of cylinders	3							
	Bore and stroke	72 mm x 70 mm (2.8 in. x 2.7 in.)							
	Total displacement	855 cm ³ (52.2 cu.in.)							
	Rated revolution	43.3 r/s (2600 rpm)							
	Fuel	Diesel fuel No.2-D [No. 1 diesel fuel if temperature is below-10°C (14°F)]							
	Starter	Electric starter with battery and glow plug, 12V, 0.8 kW							
	Lubrication	Forced lubrication by trochoidal pump							
	Cooling	Water with pressurized radiator							
	Battery	12V (45 AH)							
Capacities	Fuel tank	18 ℓ (4.8 U.S. gals)							
	Engine crankcase	3.1 ℓ (3.3 U.S. qts)							
	Engine coolant	2.9 ℓ (3.1 U.S. qts)							
	Transmission case	12 ℓ (12.7 U.S. qts)							
	Steering gear box	0.2 ℓ (0.2 U.S. qts)							
	Front axle diff. case	—				0.5 ℓ (0.5 U.S. qts) Bi-speed Turn: 2.5 ℓ (2.6 U.S. qts)			
Front axle gear case	—				0.15 ℓ (0.16 U.S. qts)				
Tires	Front	Farm 4.50-10	Farm 5.00-10	Turf 18x9.50-8	Turf 18x9.50-8	Farm 6-12B	Turf 20.5x8.00-10	Turf 20.5x8.00-10	
	Rear	7-16	8-16	29x12.00-15	31x13.5-15**	8-16	29x12.00-15	31x13.5-15**	
Dimensions	Overall length	mm (in.)	2565 (101.0)	2565 (101.0)	2565 (101.0)	2565 (101.0)	2565 (101.0)	2565 (101.0)	
	Overall width	mm (in.)	910 (35.8) 960 (37.8) 1080 (42.5)	990 (39.0) 1110 (43.7)	1140 (44.9)	1240 (48.8)	980 (38.6) 1110 (43.7)	1140 (44.9)	1240 (48.8)
	Overall height with ROPS	mm (in.)	1875 (73.7)	1900 (74.8)	1880 (74.1)	1890 (74.4)	1900 (74.8)	1880 (74.1)	1890 (74.4)
	Wheelbase	mm (in.)	1470 (57.9)	1470 (57.9)	1470 (57.9)	1470 (57.9)	1470 (57.9)	1470 (57.9)	1470 (57.9)
	Min. ground clearance	mm (in.)	230 (9.1)	255 (10.0)	240 (9.4)	250 (9.8)	240 (9.4)	215 (8.5)	215 (8.5)
	Treads	Front	mm (in.)	710 (28.0)	710 (28.0)	850 (33.5)	850 (33.5)	795 (31.3)	825 (32.5)
Rear		mm (in.)	740 (29.1) 790 (31.1) 910 (35.8)	790 (31.1) 910 (35.8)	840 (33.1)	895 (35.2)	790 (31.1) 910 (35.8)	840 (33.1)	895 (35.2)
Weight (with ROPS)	kg (lbs)	545 (1202)	555 (1224)	565 (1246)	570 (1257)	610 (1345)	615 (1356)	630 (1389)	
		Transmission case rear (rear PTO), Transmission case bottom (mid PTO) and engine front (front PTO)							
PTO shaft	Rear PTO	SAE 1-3/8 (with over running clutch) 2 speeds (9.0 and 15.5 r/s at 41.3 engine r/s) (540 and 924 rpm at 2476 engine rpm)							
	Mid PTO	USA No.5 (KUBOTA 10 tooth) Involute spline 1 speeds (40.3 r/s at 41.3 engine r/s) (2416 rpm at 2476 engine rpm)							
Clutch	Dry single plate								
Steering	Recirculating ball type manual steering or integral type power steering (if equipped)								
Transmission	Gear shift, 6 forward and 2 reverse								
Min. turning radius	m (ft)	2.0 (6.6)				2.1 (6.9)			
Brake	Internal expanding type, right and left independent with interlocking device								
Differential	Bevel gear								

Note: * Manufacture's estimate
** Bar Tire (if equipped)

B1550HST 2WD				B1550HST 4WD		
12.7 kW (17 HP)*						
9.3 kW (12.5 HP)*						
D850-5B						
Vertical, water-cooled, 4-cycle diesel						
3						
72 mm x 70 mm (2.8 in. x 2.7 in.)						
855 cm ³ (52.2 cu.in.)						
43.3 r/s (2600 rpm)						
Diesel fuel No.2-D [No. 1 diesel fuel if temperature is below-10°C (14°F)]						
Electric starter with battery and glow plug, 12V, 0.8 kW						
Forced lubrication by trochoidal pump						
Water with pressurized radiator						
12V (45 AH)						
18 ℓ (4.8 U.S. gals)						
3.1 ℓ (3.3 U.S. qts)						
2.9 ℓ (3.1 U.S. qts)						
13.5 ℓ (14.3 U.S. qts)						
0.2 ℓ (0.2 U.S. qts)						
---				0.5 ℓ (0.5 U.S. qts) Bi-speed Turn: 2.5 ℓ (2.6 U.S. qts)		
---				0.15 ℓ (0.16 U.S. qts)		
Farm 4.50-10	Farm 5.00-10	Turf 18x9.50-8	Turf 18x9.50-8	Farm 6-12B	Turf 20.5x8.00-10	Turf 20.5x8.00-10
7-16	8-16	29x12.00-15	31x13.5-15**	8-16	29x12.00-15	31x13.5-15**
2565 (101.0)	2565 (101.0)	2565 (101.0)	2565 (101.0)	2565 (101.0)	2565 (101.0)	2565 (101.0)
910 (35.8) 960 (37.8) 1080 (42.5)	990 (39.0) 1110 (43.7)	1140 (44.9)	1240 (48.8)	980 (38.6) 1110 (43.7)	1140 (44.9)	1240 (48.8)
1875 (73.7)	1900 (74.8)	1880 (74.1)	1890 (74.4)	1900 (74.8)	1880 (74.1)	1890 (74.4)
1470 (57.9)	1470 (57.9)	1470 (57.9)	1470 (57.9)	1470 (57.9)	1470 (57.9)	1470 (57.9)
230 (9.1)	255 (10.0)	240 (9.4)	250 (9.8)	240 (9.4)	215 (8.5)	215 (8.5)
710 (28.0)	710 (28.0)	850 (33.5)	850 (33.5)	795 (31.3)	825 (32.5)	895 (35.2)
790 (31.1) 910 (35.8)	790 (31.1) 910 (35.8)	840 (33.1)	895 (35.2)	790 (31.1) 910 (35.8)	840 (33.1)	895 (35.2)
560 (1235)	570 (1257)	580 (1279)	570 (1257)	625 (1387)	630 (1389)	630 (1389)
Transmission case rear (rear PTO), Transmission case bottom (mid PTO) and engine front (front PTO)						
SAE 1-3/8 2 speeds (9.0 and 14.3 r/s at 41.9 engine r/s) (540 and 858 rpm at 2517 engine rpm)						
USA No.5 (KUBOTA 10 tooth) Involute spline 1 speeds (40.9 r/s at 41.9 engine r/s) (2455 rpm at 2517 engine rpm)						
Dry single plate						
Recirculating ball type manual steering or integral type power steering (if equipped)						
Main-hydrostatic transmission, High-Low gear shift (2 forward, 2 reverse)						
2.1 (6.9)				2.3 (7.5)		
Internal expanding type, right and left independent with interlocking device						
Bevel gear						

Note: * Manufacture's estimate
 ** Bar Tire (if equipped)

SPECIFICATIONS (Continued)

Model		B1750 2WD				B1750 4WD				
Engine gross power		14.9 kW (20 HP)*								
PTO power		12.3 kW (16.5 HP)*								
Engine	Model	D950-5B								
	Type	Vertical, water-cooled, 4-cycle diesel								
	No. of cylinders	3								
	Bore and stroke	75 mm x 70 mm (3.0 in. x 2.8 in.)								
	Total displacement	927 cm ³ (56.6 cu in.)								
	Rated revolution	43.3 r/s (2600 rpm)								
	Fuel	Diesel fuel No.2-D [No. 1 diesel fuel if temperature is below -10°C (14°F)]								
	Starter	Electric starter with battery and glow plug, 12V, 0.8 kW								
	Lubrication	Forced lubrication by trochoidal pump								
	Cooling	Water with pressurized radiator								
	Battery	12V (45 AH)								
Capacities	Fuel tank	18 ℓ (4.8 U.S. gals)								
	Engine crankcase	3.1 ℓ (3.3 U.S. qts)								
	Engine coolant	3.5 ℓ (3.7 U.S. qts)								
	Transmission case	12 ℓ (12.7 U.S. qts)								
	Steering gear box	0.2 ℓ (0.2 U.S. qts)								
	Front axle diff. case	—				1.5 ℓ (1.6 U.S. qts) Bi-speed Turn: 2.5 ℓ (2.6 U.S. qts)				
	Front axle gear case	—				0.5 ℓ (0.5 U.S. qts)				
Tires	Front	Farm 5.00-10	Farm 5.00-10	Turf 18x9.50-8	Turf 18x9.50-8	Farm 6-12B	Farm 6-12	Turf 20.5x8.00-10	Turf 20.5x8.00 10	
	Rear	8-16	9.5-16	29x12.00-15	31x13.5-15**	8-16	9.5-16	29x12.00-15	31x13.5-15**	
Dimensions	Overall length	mm (in.)	2565 (101.0)	2565 (101.0)	2565 (101.0)	2565 (101.0)	2565 (101.0)	2565 (101.0)	2565 (101.0)	
	Overall width	mm (in.)	990 (39.0)	1045 (41.1)	1140 (44.9)	1240 (48.8)	1050 (41.3)	1045 (41.1)	1140 (44.9)	1240 (48.8)
			1110 (43.7)	1095 (43.1)			1110 (43.7)	1145 (45.1)		
				1145 (45.1)				1265 (49.8)		
	Overall height with ROPS	mm (in.)	1900 (74.8)	1925 (75.8)	1880 (74.1)	1890 (74.4)	1900 (74.8)	1925 (75.8)	1880 (74.1)	1890 (74.4)
	Wheelbase	mm (in.)	1470 (57.9)	1470 (57.9)	1470 (57.9)	1470 (57.9)	1470 (57.9)	1470 (57.9)	1470 (57.9)	1470 (57.9)
	Min. ground clearance	mm (in.)	255 (10.0)	285 (101.2)	240 (9.4)	250 (9.8)	240 (9.4)	255 (10.0)	215 (8.5)	215 (8.5)
Treads	Front	mm (in.)	710 (28.0)	710 (28.0)	850 (33.5)	850 (33.5)	860 (33.9)	860 (33.9)	895 (35.2)	895 (35.2)
	Rear	mm (in.)	790 (31.1)	795 (31.3)	840 (33.1)	895 (35.2)	790 (31.1)	795 (31.3)	840 (33.1)	895 (35.2)
		910 (40.0)	845 (33.3)	910 (35.8)			895 (35.2)	1015 (40.0)		
Weight (with ROPS)		kg (lbs)	555 (1224)	570 (1257)	565 (1246)	570 (1257)	620 (1367)	630 (1384)	625 (1378)	630 (1389)
		Transmission case rear (rear PTO), Transmission case bottom (mid PTO) and engine front (front PTO)								
PTO shaft	Rear PTO	SAE 1-3/8 (with over running clutch) 2 speeds (9.0 and 15.5 r/s at 41.3 engine r/s) (540 and 924 rpm at 2476 engine rpm)								
	Mid PTO	USA No.5 (KUBOTA 10 tooth) Involute spline 1 speeds (40.3 r/s at 41.3 engine r/s) (2416 rpm at 2476 engine rpm)								
Clutch		Dry single plate								
Steering		Recirculating ball type manual steering or integral type power steering (if equipped)								
Transmission		Gear shift, 6 forward and 2 reverse								
Min. turning radius		m (ft)	2.0 (6.6)				2.0 (6.6)			
Brake		Internal expanding type, right and left independent with interlocking device								
Differential		Bevel gear								

Note: * Manufacture's estimate
** Bar Tire (if equipped)

B1750HST 2WD				B1750HST 4WD			
14.9 kW (20 HP)*							
11.2 kW (15.5 HP)*							
D950-5B							
Vertical, water-cooled, 4-cycle diesel							
3							
75 mm x 70 mm (3.0 in. x 2.8 in.)							
927 cm ³ (56.6 cu.in.)							
43.3 r/s (2600 rpm)							
Diesel fuel No.2-D [(No. 1 diesel fuel if temperature is below -10°C (14°F)]							
Electric starter with battery and glow plug, 12V, 0.8 kW							
Forced lubrication by trochoidal pump							
Water with pressurized radiator							
12V (45 AH)							
18 ℓ (4.8 U.S. gals)							
3.1 ℓ (3.3 U.S. qts)							
3.5 ℓ (3.7 U.S. qts)							
13.5 ℓ (14.3 U.S. qts)							
0.2 ℓ (0.2 U.S. qts)							
—				1.5 ℓ (1.6 U.S. qts) Bi-speed Turn: 2.5 ℓ (2.6 U.S. qts)			
—				0.5 ℓ (0.5 U.S. qts)			
Farm 5.00-10	Farm 5.00-10	Turf 18x9.50-8	Turf 18x9.50-8	Farm 6-12B	Farm 6-12	Turf 20.5x8.00-10	Turf 20.5x8.00-10
8-16	9.5-16	29x12.00-15	31x13.5-15**	8-16	9.5-16	29x12.00-15	31x13.5-15**
2565 (101.0)	2565 (101.0)	2565 (101.0)	2565 (101.0)	2565 (101.0)	2565 (101.0)	2565 (101.0)	2565 (101.0)
990 (39.0) 1110 (43.7)	1045 (41.1) 1095 (43.1) 1145 (45.1) 1265 (49.8)	1140 (44.9)	1240 (48.8)	1050 (41.3) 1110 (43.7)	1045 (41.1) 1095 (43.1) 1145 (45.1) 1265 (49.8)	1140 (44.9)	1240 (48.8)
1900 (74.8)	1925 (75.8)	1880 (74.1)	1890 (74.4)	1900 (74.8)	1925 (75.8)	1880 (74.1)	1890 (74.4)
1470 (57.9)	1470 (57.9)	1470 (57.9)	1470 (57.9)	1470 (57.9)	1470 (57.9)	1470 (57.9)	1470 (57.9)
255 (10.0)	285 (101.2)	240 (9.4)	250 (9.8)	240 (9.4)	255 (10.0)	215 (8.5)	215 (8.5)
710 (28.0)	710 (28.0)	850 (33.5)	850 (33.5)	860 (33.9)	860 (33.9)	895 (35.2)	895 (35.2)
790 (31.1) 910 (40.0)	795 (31.3) 845 (33.3) 895 (35.2) 1015 (40.0)	840 (33.1)	895 (35.2)	790 (31.1) 910 (35.8)	795 (31.3) 845 (33.3) 895 (35.2) 1015 (40.0)	840 (33.1)	895 (35.2)
575 (1268)	585 (1290)	580 (1279)	585 (1240)	635 (1400)	645 (1422)	640 (1411)	645 (1422)
Transmission case rear (rear PTO), Transmission case bottom (mid PTO) and engine front (front PTO)							
SAE 1-3/8 2 speeds (9.0 and 14.3 r/s at 41.9 engine r/s) (540 and 858 rpm at 2517 engine rpm)							
USA No.5 (KUBOTA 10 tooth) Involute spline 1 speeds (40.9 r/s at 41.9 engine r/s) (2455 rpm at 2517 engine rpm)							
Dry single plate							
Recirculating ball type manual steering or integral type power steering (if equipped)							
Main-hydrostatic transmission, High-Low gear shift (2 forward, 2 reverse)							
2.1 (6.9)				2.2 (7.2)			
Internal expanding type, right and left independent with interlocking device							
Bevel gear							

Note: * Manufacture's estimate
 ** Bar Tire (if equipped)

SPECIFICATIONS (Continued)

Model		B2150 2WD			B2150 4WD			
Engine gross power		17.9 kW (24 HP)*						
PTO power		14.9 kW (20 HP)*						
Engine	Model	V1200-5B						
	Type	Vertical, water-cooled, 4-cycle diesel						
	No. of cylinders	4						
	Bore and stroke	75 mm x 70 mm (3.0 in. x 2.8 in.)						
	Total displacement	1237 cm ³ (75.4 cu.in.)						
	Rated revolution	43.3 r/s (2600 rpm)						
	Fuel	Diesel fuel No.2-D [No. 1 diesel fuel if temperature is below -10°C (14°F)]						
	Starter	Electric starter with battery and glow plug, 12V, 1.0 kW						
	Lubrication	Forced lubrication by trochoidal pump						
	Cooling	Water with pressurized radiator						
Battery		12V (65 AH)						
Capacities	Fuel tank	28 ℓ (7.4 U.S. gals)						
	Engine crankcase	4.2 ℓ (4.4 U.S. qts)						
	Engine coolant	3.9 ℓ (4.1 U.S. qts)						
	Transmission case	18 ℓ (19 U.S. qts)						
	Steering gear box	0.2 ℓ (0.2 U.S. qts)						
	Front axle diff. case	—			1.5 ℓ (1.6 U.S. qts)			
Front axle gear case	—			0.5 ℓ (0.5 U.S. qts)				
Tires	Front	Farm 4.00-12	Farm 6.50-10	Turf 23x8.50-12	Farm 6-12	Farm 6-12	Turf 24x8.50-12	
	Rear	8.3-24	12.4-16	13.6-16	12.4-16	8.3-24	13.6-16	
Dimensions	Overall length	mm (in.)	2780 (109.4)	2780 (109.4)	2780 (109.4)	2780 (109.4)	2780 (109.4)	
	Overall width	mm (in.)	1095 (43.1) 1135 (44.7)	1365 (53.7)	1405 (55.3)	1365 (53.7)	1095 (43.1) 1135 (44.7)	1405 (55.3)
	Overall height with ROPS	mm (in.)	1950 (76.8)	1940 (76.4)	1960 (77.2)	1940 (76.4)	1950 (76.8)	1960 (77.2)
	Wheelbase	mm (in.)	1600 (63)	1600 (63)	1600 (63)	1600 (63)	1600 (63)	1600 (63)
	Min. ground clearance	mm (in.)	235 (9.3)	235 (9.3)	235 (9.3)	235 (9.3)	235 (9.3)	235 (9.3)
	Treads	Front	mm (in.)	830 (32.7)	905 (35.6)	900 (35.4)	900 (35.4)	900 (35.4)
Rear		mm (in.)	890 (35.0) 930 (36.6)	1050 (41.3)	1050 (41.3)	1050 (41.3)	890 (35.0) 930 (36.6)	1050 (41.3)
Weight (with ROPS)		kg (lbs)	760 (1674)	777 (1711)	783 (1725)	830 (1828)	828 (1824)	840 (1850)
		Transmission case rear (rear PTO), Transmission case bottom (mid PTO) and engine front (front PTO)						
PTO shaft	Rear PTO	SAE 1-3/8 (with over running clutch) 2 speeds (9.0 and 12.6 r/s at 41.1 engine r/s) (540 and 755 rpm at 2467 engine rpm)						
	Mid PTO	USA No.5 (KUBOTA 10 tooth) Involute spline 2 speeds (28.4 r/s at 39.7r/s at 41.1 engine r/s) (1701 rpm at 2379rpm at 2467 engine rpm)						
Clutch		Dry two plates (live PTO)						
Steering		Recirculating ball type manual steering or integral type power steering (if equipped)						
Transmission		Gear shift, 9 forward and 3 reverse						
Min. turning radius		m (ft)	2.4 (7.9)			2.8 (9.2)		
Brake		Internal expanding type, right and left independent with interlocking device						
Differential		Bevel gear						

Note: * Manufacture's estimate)

B2150HST 2WD			B2150HST 4WD		
17.9 kW (24 HP)*					
13.4 kW (18 HP)*					
V1200-58					
Vertical, water-cooled, 4-cycle diesel					
4					
75 mm x 70 mm (3.0 in. x 2.8 in.)					
1237 cm ³ (75.4 cu.in.)					
43.3 r/s (2600 rpm)					
Diesel fuel No.2-D [No. 1 diesel fuel if temperature is below -10°C (14°F)]					
Electric starter with battery and glow plug, 12V, 1.0 kW					
Forced lubrication by trochoidal pump					
Water with pressurized radiator					
12V (65 AH)					
28 ℓ (7.4 U.S. gals)					
4.2 ℓ (4.4 U.S. qts)					
3.9 ℓ (4.1 U.S. qts)					
18 ℓ (19 U.S. qts)					
0.2 ℓ (0.2 U.S. qts)					
---			1.5 ℓ (1.6 U.S. qts)		
---			0.5 ℓ (0.5 U.S. qts)		
Farm 4.00-12	Farm 6.50-10	Turf 23x8.50-12	Farm 6-12	Farm 6-12	Turf 24x8.50-12
8.3-24	12.4-16	13.6-16	12.4-16	8.3-24	13.6-16
2780 (109.4)	2780 (109.4)	2780 (109.4)	2780 (109.4)	2780 (109.4)	2780 (109.4)
1095 (43.1) 1135 (44.7)	1365 (53.7)	1405 (55.3)	1365 (53.7)	1095 (43.1) 1135 (44.7)	1405 (55.3)
1950 (76.8)	1940 (76.4)	1960 (77.2)	1940 (76.4)	1950 (76.8)	1960 (77.2)
1600 (63)	1600 (63)	1600 (63)	1600 (63)	1600 (63)	1600 (63)
235 (9.3)	235 (9.3)	235 (9.3)	235 (9.3)	235 (9.3)	235 (9.3)
830 (32.7)	905 (35.6)	900 (35.4)	900 (35.4)	900 (35.4)	935 (36.8)
890 (35.0) 930 (36.6)	1050 (41.3)	1050 (41.3)	1050 (41.3)	890 (35.0) 930 (36.6)	1050 (41.3)
765 (1685)	782 (1722)	788 (1736)	835 (1839)	833 (1835)	845 (1861)
Transmission case rear (rear PTO), Transmission case bottom (mid PTO) and engine front (front PTO)					
SAE 1-3/8 2 speeds (9.0 and 12.5 r/s at 40.1 engine r/s) (540 and 748 rpm at 2408 engine rpm)					
USA No.5 (KUBOTA 10 tooth) Involute spline 2 speeds (28.4 r/s at 39.3r/s at 40.1 engine r/s) (1701 rpm at 2355rpm at 2408 engine rpm)					
Dry single plate (live PTO)					
Recirculating ball type manual steering or integral type power steering (if equipped)					
Main-hydrostatic transmission; range-gear shift, (3 forward and 3 reverse)					
2.4 (7.9)			2.8 (9.2)		
Internal expanding type, right and left independent with interlocking device					
Bevel gear					

Note: * Manufacture's estimate

DIMENSION

Maximum dimension is shown against farm tire variation.

Unit: mm (in.)

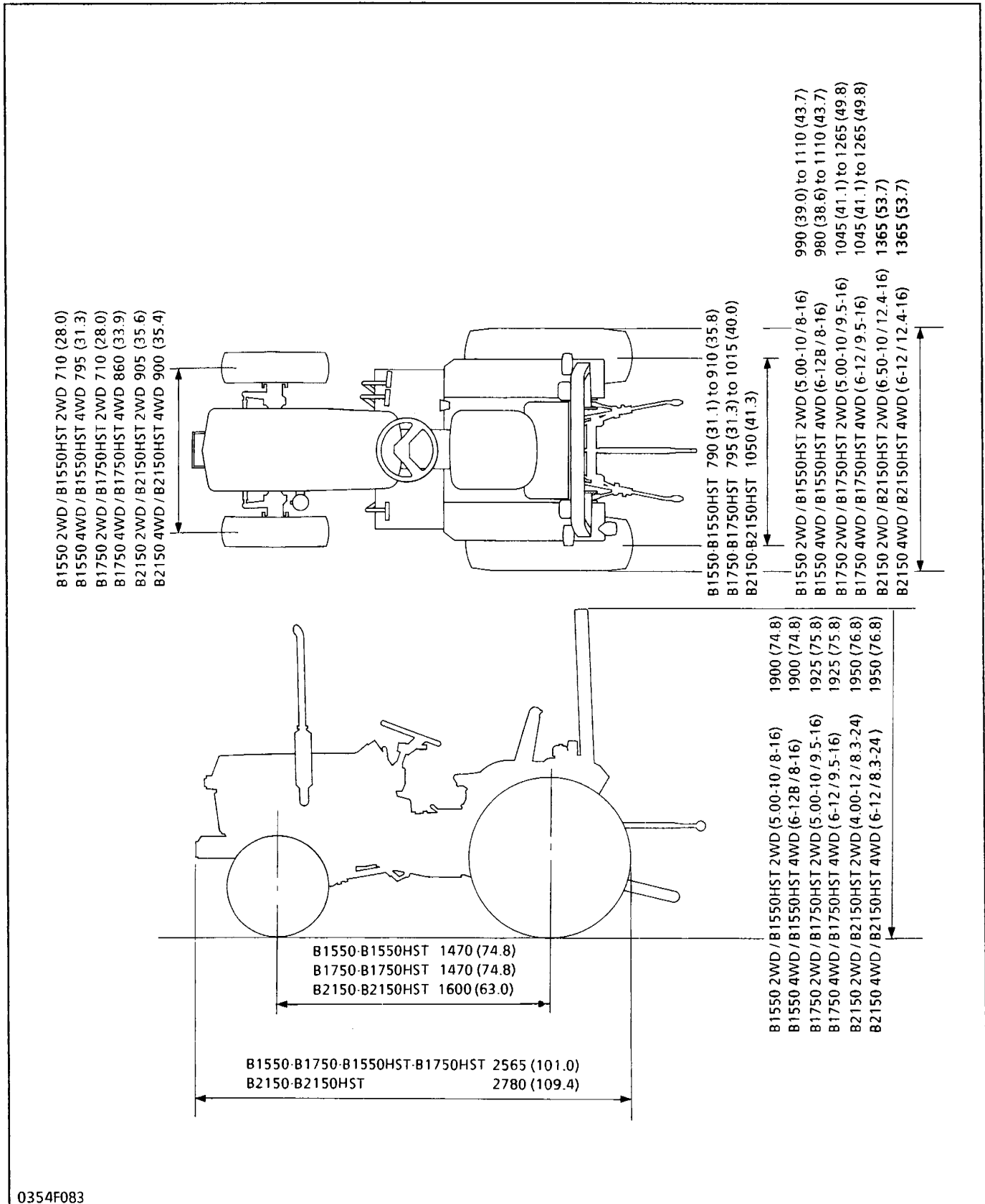

0354F083

M MECHANISM

CONTENTS

F	FEATURES	M.F-1		
1	ENGINE	M.1-1		
	[1] ENGINE BODY	M.1-2		
	(1) Cylinder Block	M.1-2		
	(2) Cylinder Head	M.1-2		
	(3) Crankshaft	M.1-3		
	(4) Piston and Piston Ring	M.1-4		
	(5) Connecting Rod	M.1-5		
	(6) Camshaft and Fuel Camshaft	M.1-5		
	(7) Rocker Arm Assembly	M.1-6		
	(8) Inlet and Exhaust Valves	M.1-6		
	(9) Valve Timing	M.1-6		
	(10) Flywheel	M.1-7		
	(11) Air Cleaner	M.1-7		
	[2] LUBRICATING SYSTEM	M.1-8		
	(1) Relief Valve	M.1-10		
	(2) Oil Filter Cartridge	M.1-10		
	(3) Oil Switch	M.1-11		
	(4) Oil Pump	M.1-11		
	[3] COOLING SYSTEM	M.1-12		
	(1) Water Pump	M.1-13		
	(3) Thermostat	M.1-13		
	(4) Radiator	M.1-14		
	(5) Radiator Cap	M.1-14		
	[4] FUEL SYSTEM	M.1-15		
	(1) Fuel Filter	M.1-16		
	(2) Fuel Lift Pump	M.1-17		
	(3) Fuel Injection Pump	M.1-18		
	(4) Fuel Injection Nozzle	M.1-21		
	(5) Governor	M.1-21		
2	CLUTCH	M.2-1		
	[1] DRY TYPE, SINGLE PLATE CLUTCH	M.2-1		
	[2] DRY TYPE, DUAL STAGE CLUTCH	M.2-3		
3	TRANSMISSION	M.3-1		
	[1] TRAVELING SYSTEM	M.3-3		
	(1) Main Gear Shift Section	M.3-3		
	(2) Hydrostatic Transmission B1550HST-B1750HST	M.3-4		
	B2150HST	M.3-18		
	(3) Auxiliary Gear Shift Section	M.3-32		
	(4) Front Wheel Drive Section	M.3-33		
	[2] PTO SYSTEM	M.3-33		
	(1) Rear PTO Shift Section	M.3-33		
	(2) Mid PTO Section	M.3-35		
	(3) Front PTO Section	M.3-36		
	(4) One-way Clutch Cam Section	M.3-36		
4	REAR AXLE	M.4-1		
	[1] DIFFERENTIAL FUNCTIONING	M.4-2		
	[2] DIFFERENTIAL LOCK	M.4-3		
5	BRAKE	M.5-1		
6	FRONT AXLE	M.6-1		
	[1] FRONT WHEEL ALIGNMENT	M.6-1		
	[2] STRUCTURE	M.6-2		
	(1) Two Wheel Drive Type	M.6-2		
	(2) Four Wheel Drive Type	M.6-3		
	B1550-B1550HST	M.6-3		
	B1750-B2150-B1750HST- B2150HST	M.6-4		
	Bi-speed Turn	M.6-5		
7	STEERING	M.7-1		
	[1] MANUAL STEERING	M.7-1		
	[2] POWER STEERING	M.7-2		
8	HYDRAULIC SYSTEM	M.8-1		
	[1] HYDRAULIC PUMP	M.8-5		
	[2] CONTROL VALVE	M.8-6		
	[2]-1 OIL FLOW	M.8-7		
	[2]-2 FEEDBACK LINKAGE FOR POSITION CONTROL	M.8-11		
	[3] HYDRAULIC BLOCK TYPE OUTLET	M.8-12		
	B1550-B1750-B1550HST B1750HST	M.8-12		
	B2150-B2150HST	M.8-15		
	[4] OIL COOLER	M.8-18		
9	ELECTRICAL SYSTEM	M.9-1		
	[1] WIRING DIAGRAM AND ELECTRICAL CIRCUIT	M.9-1		
	[2] STARTING SYSTEM	M.9-5		
	(1) Starter Motor	M.9-6		

(2) Starter	M.9-10
(3) Glow Plug	M.9-12
(4) Safety Switch	M.9-12
[3] ENGINE KEY SWITCH SHUT-OFF SYSTEM	M.9-13
(1) Operation of Timer Relay.....	M.9-14
(2) Fuel Cut Off Solenoid.....	M.9-15
[4] CHARGING SYSTEM	M.9-16
(1) AC Dynamo	M.9-17
(2) Regulator	M.9-17
(3) Operation of Charging System	M.9-18
[5] LIGHTING SYSTEM	M.9-20
(1) Head Light	M.9-21
(2) Hazard Light	M.9-21
[6] EASY CHECKER	M.9-24
(1) Indication Items	M.9-25
(2) Low Engine Oil Pressure	M.9-25
[7] GAUGE	M.9-26
(1) Fuel Quantity	M.9-26
(2) Coolant Temperature	M.9-27

10 OTHERS _____ M.10-1

[1] TIRES	M.10-1
[1]-1 TYPES OF TIRE	M.10-1
[1]-2 TREAD ADJUSTMENT	M.10-2
[1]-3 WHEEL HUB.....	M.10-4
[1]-4 TIRE PRESSURE	M.10-4
[1]-5 TIRE LIQUID INJECTION.....	M.10-5
[2] SPECIFICATION OF IMPLEMENT LIMITATIONS	M.10-8
[3] WIRING DIAGRAM AND ELECTRICAL CIRCUIT (for Canada)	M.10-10
[4] CHARGING SYSTEM for Canada	M.10-12

F FEATURES

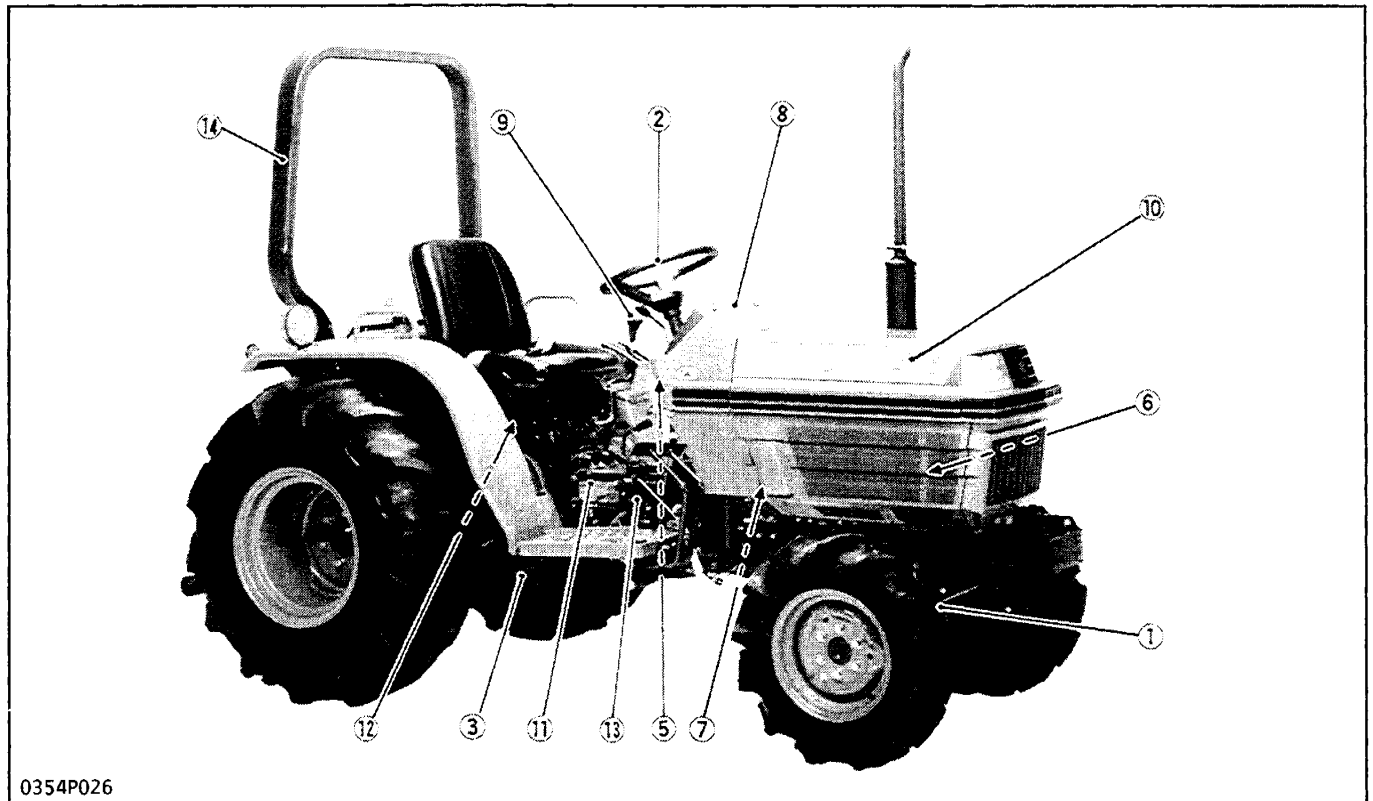

0354P026

- | | |
|---|---|
| <p>(1) Bi-speed Turn (If equipped)
(Small turning radius)</p> <p>(2) Integral Power Steering (If equipped)</p> <p>(3) Standard Mid PTO</p> <p>(4) Simultaneous Mounting of Both the Mid Mount Mower and Front Loader
(Loader is fully-compatible with the mower)</p> <p>(5) Engine Key Shut-Off System
(Engine key switch)</p> <p>(6) Reverse Fan Blade for Cooling
(Forward air flow keeps away dust and fumes)</p> <p>(7) Large Hydraulic Pump</p> <p>(8) Combination Panel of Easy Checker
(Indicators for charging system, engine oil pressure and glow plug, fuel gauge and coolant temperature gauge)</p> | <p>(9) Main Shift Lever Located in the Left Side of Transmission</p> <p>(10) New Design (Familiar with L-series)</p> <p>(11) Variation of Transmission
(Mechanical Transmission and Hydrostatic Transmission for all models)</p> <p>(12) Position Control Valve
(Shockless mechanism for smooth and comfortable operation)</p> <p>(13) Hydraulic Block Type Outlet
(Outlet has the flow priority valve for power steering)</p> <p>(14) ROPS</p> |
|---|---|

1 ENGINE

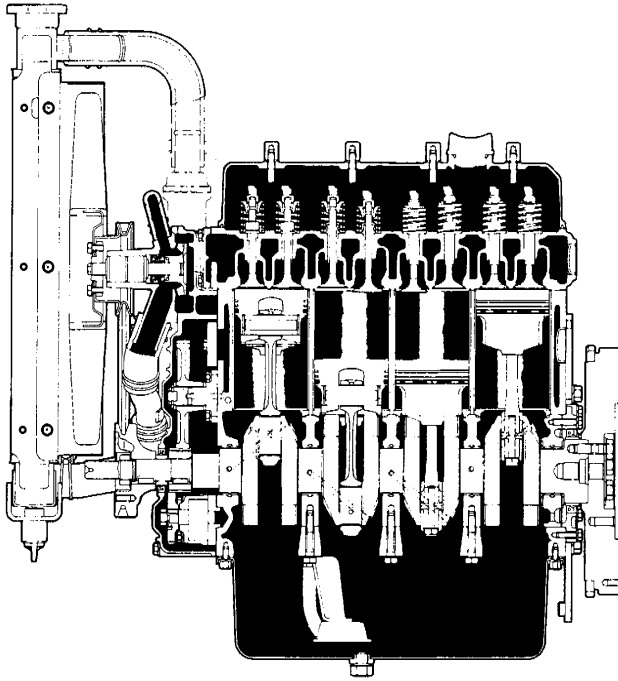

0107F009

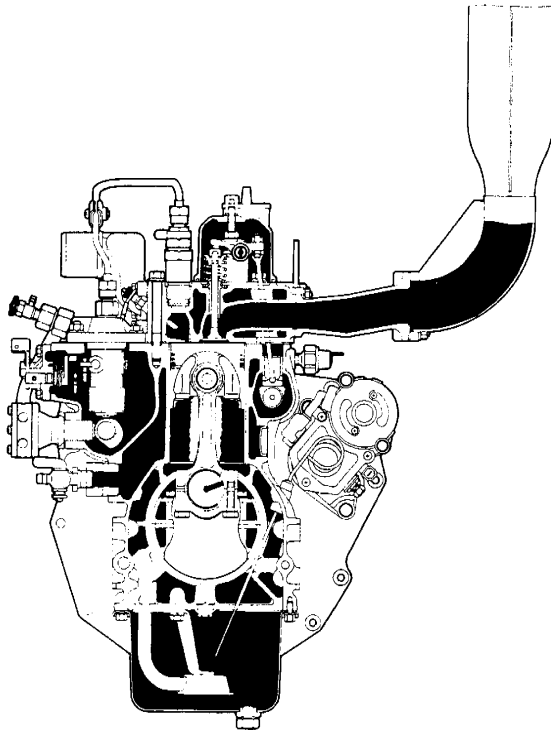

0107F010

The D850-5B, D950-5B and V1200-5B are vertical, water-cooled, 4-cycle diesel engine.

This is incorporated KUBOTA's foremost technologies. With KUBOTA's spherical combustion chamber, well-known Bosch K type injection pump and the well-balanced designs, they give greater power, low fuel consumption, little vibration and quiet operation.

[1] ENGINE BODY

(1) Cylinder Block

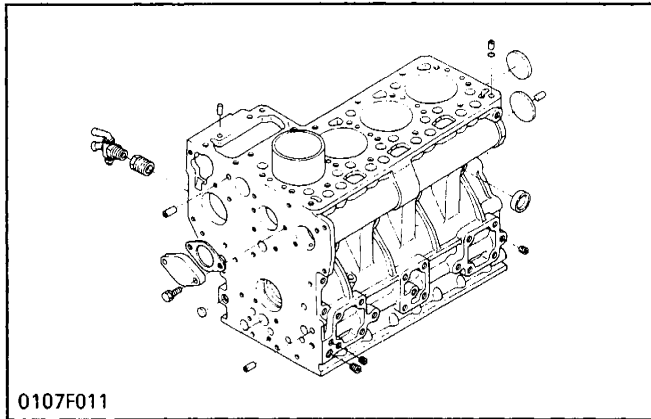

The engine has a high durability tunnel-type cylinder in which the crankshaft bearing part is constructed in a body. Furthermore, dry-type cylinder liners, being pressure-fitted into cylinders, allow effective cooling, less distortion, and greater wear-resistance. The noise level is reduced to a minimum because each cylinder has its own chamber.

(2) Cylinder Head

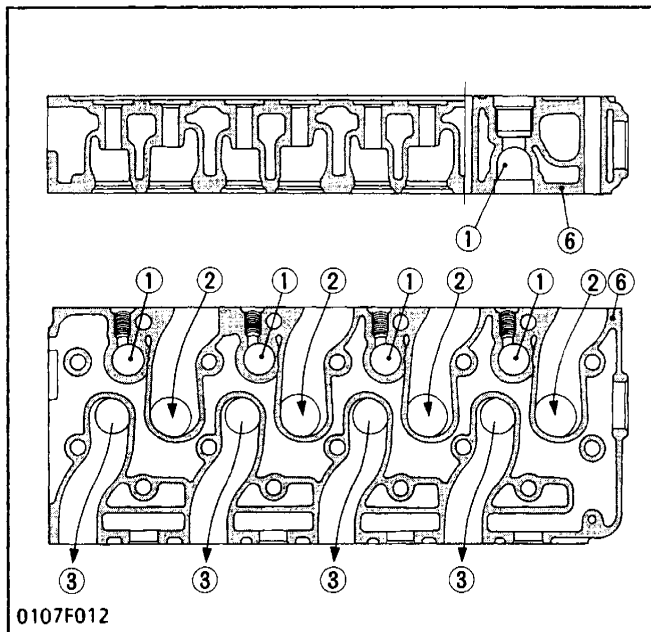

The cross-flow type inlet/exhaust ports in this engine have their openings at both sides of the cylinder head. Because overlaps of inlet/exhaust ports are smaller than in ports of other types which have openings on one side, the suction air can be protected from being heated and expanded by heated exhaust air. The cool, high density suction air has high volume efficiency and raises the power of the engine. Furthermore, distortion of the cylinder head by heated exhaust air is reduced because suction ports are arranged alternately. The combustion chamber is of KUBOTA's exclusive spherical combustion chamber type. Suction air is whirled to be mixed effectively with fuel, prompting combustion and reducing fuel consumption.

In the combustion chamber are installed throttle type injection nozzle and rapid heating sheathed type glow plug. This glow plug assures easier than ever engine starts even at -15°C (5°F).

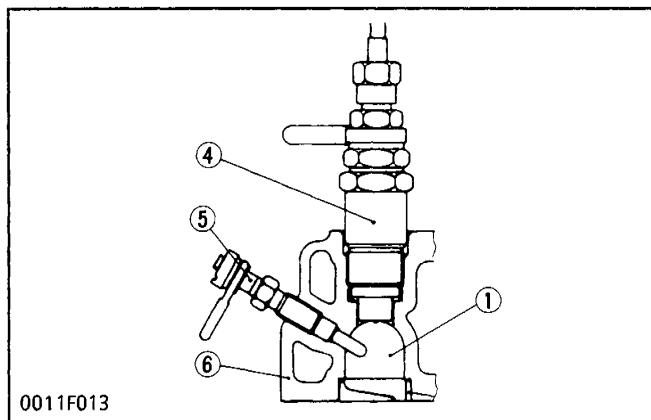

- | | |
|------------------------|---------------------|
| (1) Combustion Chamber | (4) Nozzle Assembly |
| (2) Suction | (5) Glow Plug |
| (3) Exhaust | (6) Cylinder Head |

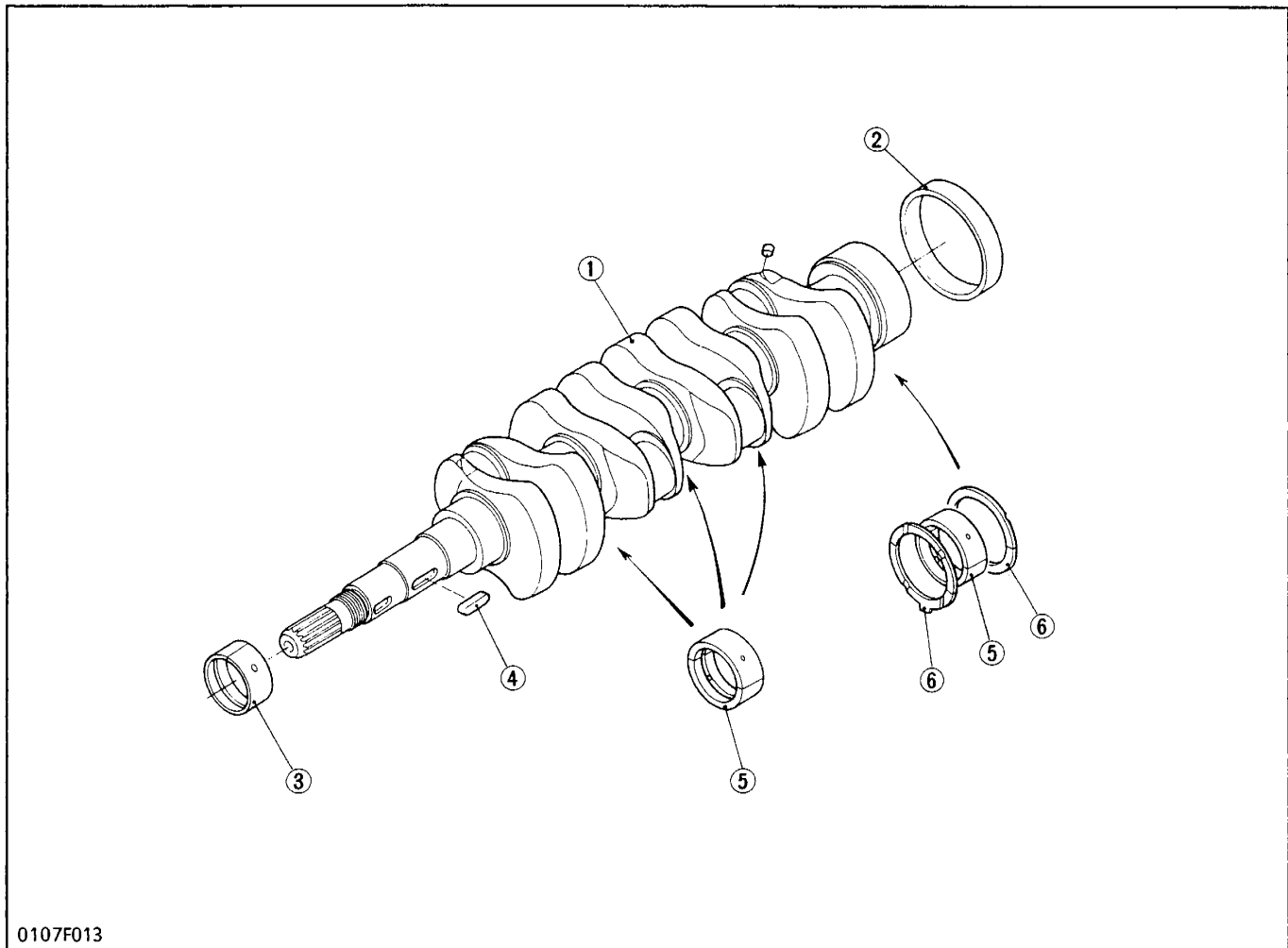
(3) Crankshaft

(1) Crankshaft
(2) Crankshaft Sleeve

(3) Crankshaft Bearing 1
(4) Feather Key

(5) Crankshaft Bearing 2

(6) Thrust Bearing

The crankshaft (1) is driven by the pistons and connecting rods, and translates its reciprocating movement into a circular movement. It also drives the oil pump, camshaft and fuel camshaft.

The counterweights, which are cast together with the crankshaft, prevent a large force of inertia from partially working on the crankshaft, consequently reducing the wear of the crankshaft bearings and lessening the temperature rise of the lubricating oil.

Crankshaft journals, crankpins and oil seal sliding section are induction-hardened to increase wear

resistance.

Crankshaft journals are supported by the main bearing cases in which a bearing is used.

Crankshaft bearing 1 (3) at the front end is a solid type bushing and the four bearings 2 (5) behind are split type. Thrust bearings (6) are mounted on both sides of the main bearing case at the flywheel side.

Crankshaft bearings and thrust bearings are plated with a special alloy to raise wear resistance quality. Furthermore the crankshaft, crankshaft bearings and main bearing cases have oil holes.

(4) Piston and Piston Ring

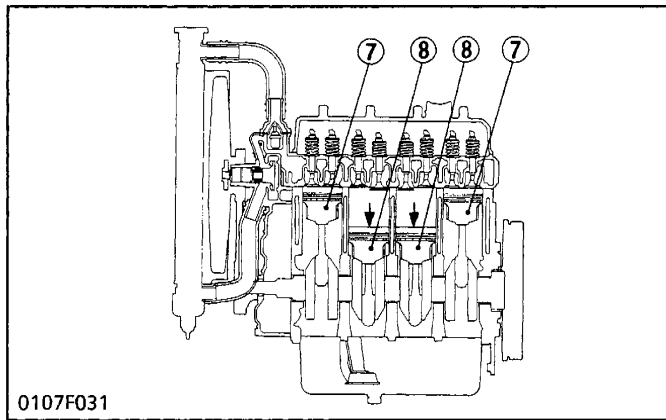
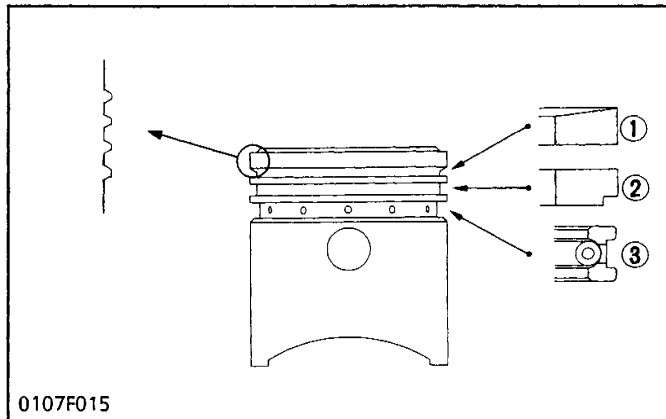
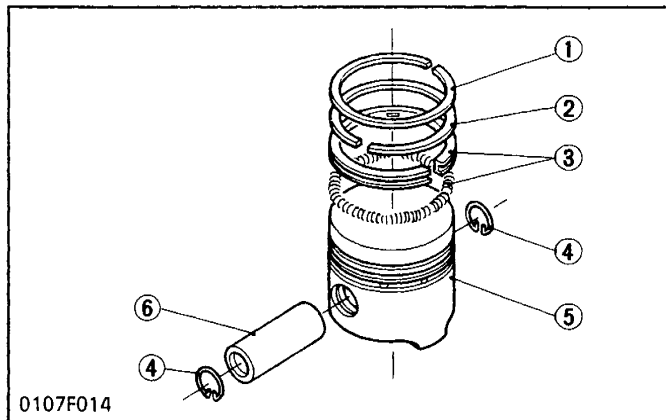

Piston circumference has a special elliptic shape in consideration of expansion due to explosion heat. Piston head is flatformed. Grooves are cut round the top section of the piston. These grooves help to dissipate heat and prevent scuffing. Piston (5) is made of special aluminum alloy of low thermal expansion and high temperature resistance.

Compression ring 1 (1) is of the key stone type which can stand against heavy load, and the sliding surface to the cylinder wall is shaped into barrel face which is well fitted to the wall and plated with hard chrome.

Compression ring 2 (2) is of the under-cut type which is effective to prevent oil rising.

Oil ring (3) is effective to scrape oil because it is closely fitted to the cylinder wall by a coil expander and the upper and lower ends of its sliding surface are cut diagonally to raise face pressure to the cylinder walls.

Some scraped oil is forced into the inside of piston through the oil escape holes of rings and piston. The oil ring is plated with hard chrome to increase wear resistance quality.

■ IMPORTANT

- Note that the piston 2's (8) in the No.2 and No.3 cylinders have different profile from the pistons (7) in the No.1 and No.4 cylinders.

The piston 2 (8) is marked "2" on the head. Be sure to install the pistons (7) (8) to each original cylinders.

- | | |
|--------------------------|----------------|
| (1) Compression Ring 1 | (5) Piston |
| (2) Compression Ring 2 | (6) Piston Pin |
| (3) Oil Ring | (7) Piston |
| (4) Piston Pin Snap Ring | (8) Piston 2 |

(5) Connecting Rod

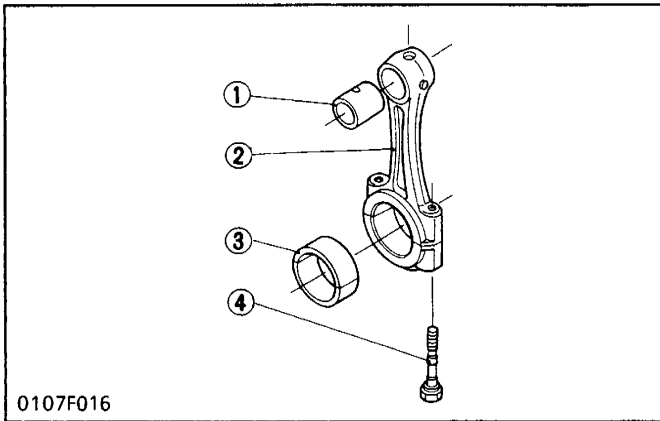

- (1) Small End Bushing
- (2) Connecting Rod
- (3) Crank Pin Bearing
- (4) Connecting Rod Screw

(6) Camshaft and Fuel Camshaft

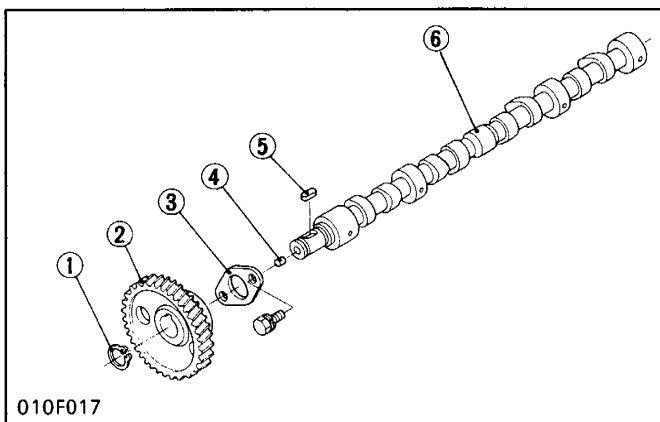

The camshaft (6) is made of special cast iron and the journal and cam sections are chilled to resist wear. The journal sections are force-lubricated. The fuel camshaft (12) controls the reciprocating movement of the injection pump, and is equipped with a ball to control the governor. The fuel camshaft is made of carbon steel and the cam sections are quenched and tempered to provide greater wear resistance.

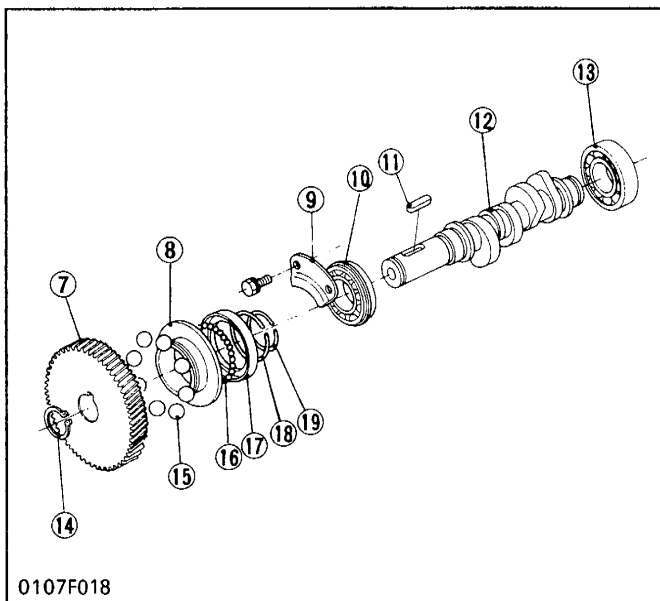

- (1) External Snap Ring
- (2) Cam Gear
- (3) Camshaft Stopper
- (4) Plug
- (5) Feather Key
- (6) Camshaft
- (7) Injection Pump Gear
- (8) Governor Sleeve
- (9) Fuel Camshaft Stopper
- (10) Ball Bearing
- (11) Feather Key
- (12) Fuel Camshaft
- (13) Ball Bearing
- (14) External Snap Ring
- (15) Steel Ball
- (16) Steel Ball
- (17) Ball Case
- (18) Ball Case Snap Ring
- (19) Governor Sleeve Snap Ring

(7) Rocker Arm Assembly

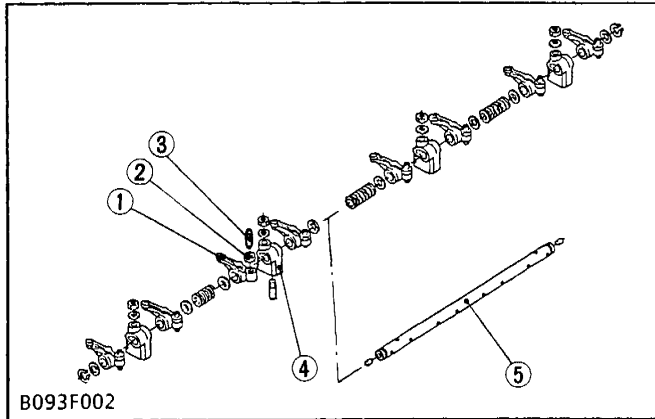

The rocker arm assembly includes the rocker arms (1), rocker arm brackets (4) and rocker arm shaft (5) and converts the reciprocating movement of the push rods to an open/close movement of the inlet and exhaust valves.

Lubricating oil is pressurized through the bracket to the rocker arm shaft, which serves as a fulcrum so that the rocker arm and the entire system are lubricated sufficiently

- (1) Rocker Arm
- (2) Lock Nut
- (3) Adjusting Screw
- (4) Rocker Arm Bracket
- (5) Rocker Arm Shaft

(8) Inlet and Exhaust Valves

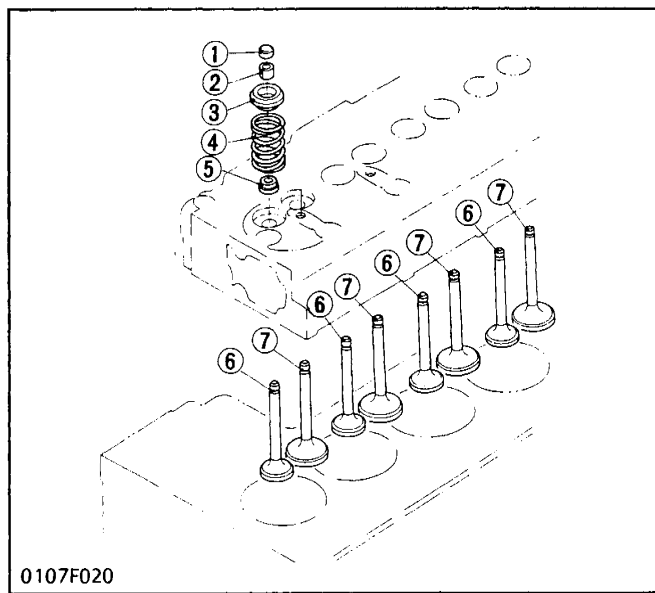

The inlet and exhaust valves (7), (6) and their guides are different from each other. Other parts, such as valve springs (4), valve spring retainers (3), valve spring collets (2), valve stem seals (5), and valve caps (1) are the same for both the inlet and exhaust valves. All contact or sliding parts are quenched and tempered to resist wear.

- (1) Valve Cap
- (2) Valve Spring Collet
- (3) Valve Spring Retainer
- (4) Valve Spring
- (5) Valve Stem Seal
- (6) Exhaust Valve
- (7) Inlet Valve

(9) Valve Timing

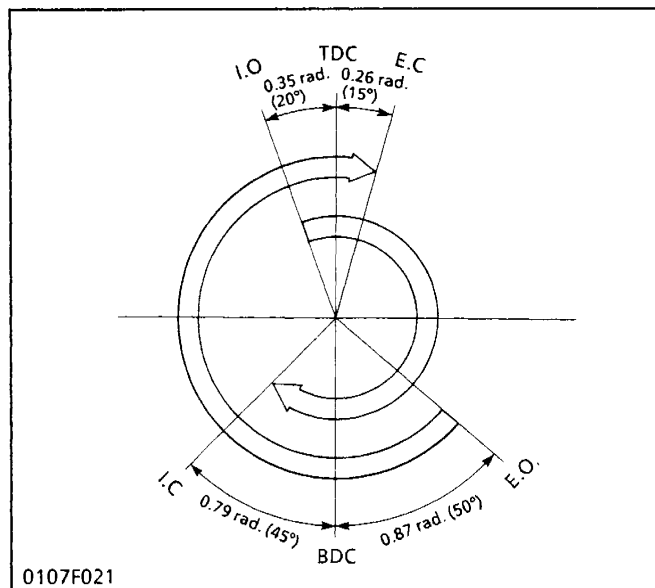

The valve opening and closing timing is extremely important for effectively intaking air into the cylinder and sufficiently exhaust gas. An appropriate timing can be obtained by aligning the alignment marks on the crank gear and cam gear.

Inlet valve open (I.O)	0.35 rad. (20°) before T.D.C.
Inlet valve close (I.C)	0.79 rad (45°) after B.D.C.
Exhaust valve open (E.O)	0.87 rad. (50°) before B.D.C.
Exhaust valve close (E.C)	0.26 rad. (15°) after T.D.C.

0107F021

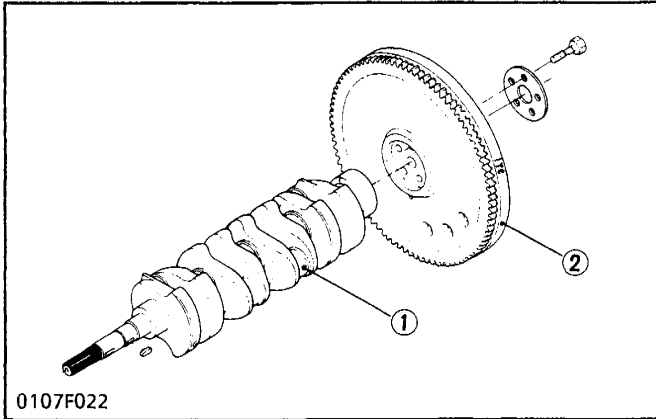
(10) Flywheel

The flywheel is connected with the crankshaft, it stores the rotating force in the combustion stroke as inertial energy to rotate the crankshaft smoothly.

The flywheel periphery is provided with marks showing fuel injection timing and top dead center.

The flywheel and crankshaft can be fixed to each other at a certain point according to the arrangement of flywheel mounting screw hole.

- (1) Crankshaft
- (2) Flywheel

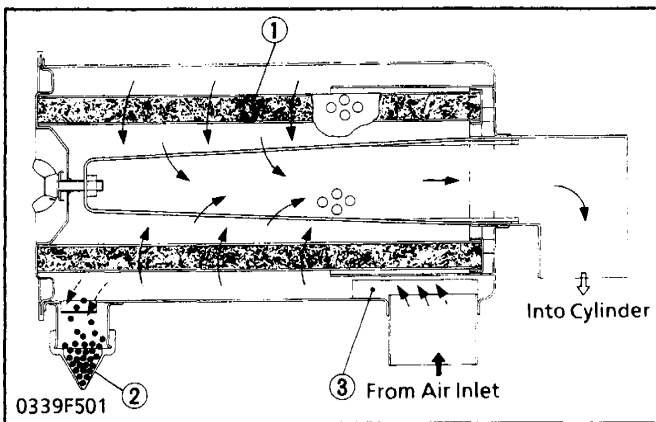
(11) Air Cleaner

The air cleaner is of a dry type with evacuator valve for easy maintenance. Sucked air is caused to flow in a whirling way with air guide (3). As a result, heavier dust particles circulate around the circumference and accumulate in the evacuator valve (2). Minute dust, while circulating in the air flow, is absorbed by the element (1) and thus prevented from entering the engine.

- (1) Air Cleaner Element
- (2) Evacuator Valve
- (3) Air Guide

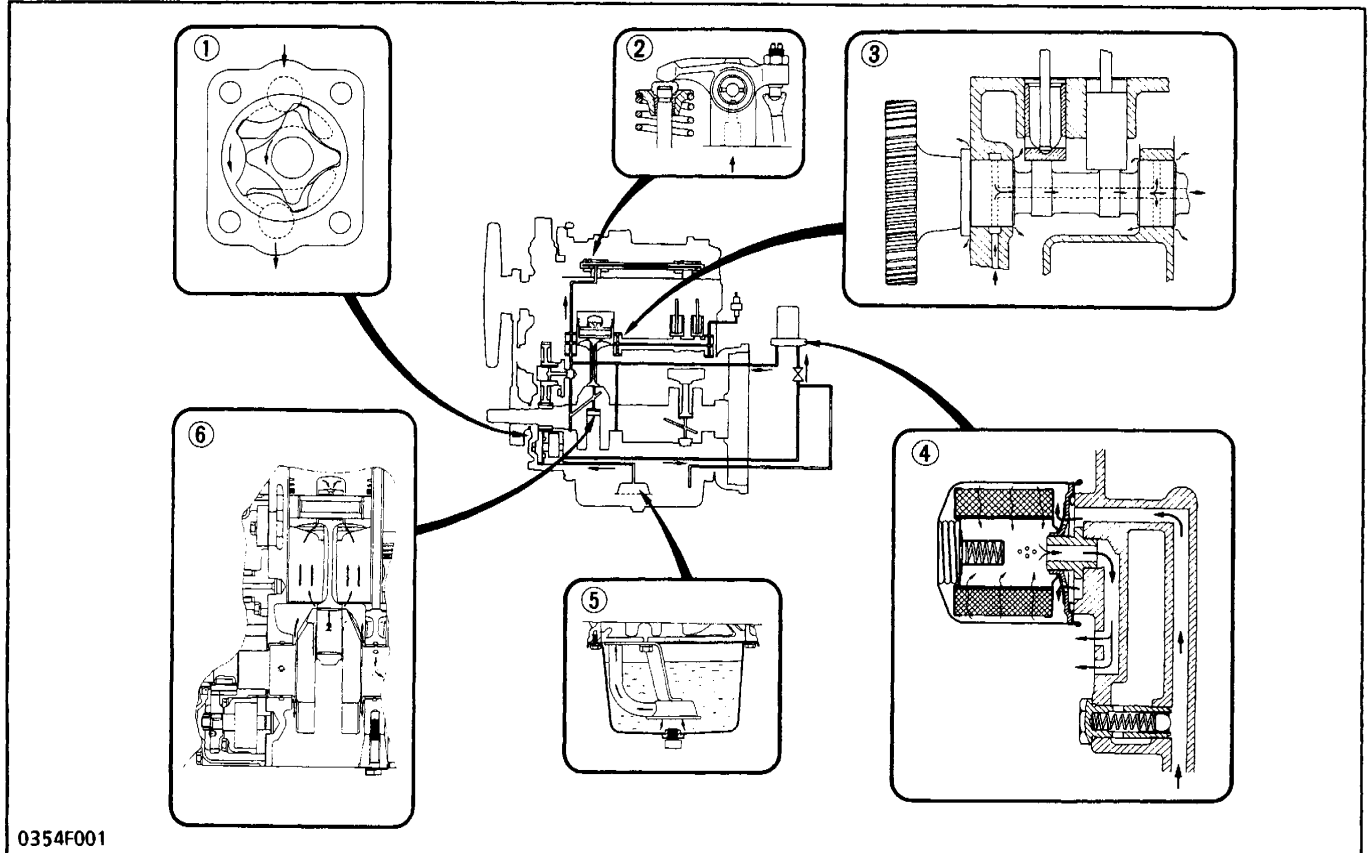
[2] LUBRICATING SYSTEM

0354F001

- (1) Oil Pump
- (2) Rocker Arm and Rocker Arm Shaft
- (3) Camshaft

- (4) Oil Filter Cartridge and Relief Valve
- (5) Oil Strainer
- (6) Crankshaft and Piston

This engine lubricating system consists of oil strainer, oil pump, relief valve, oil filter cartridge and oil switch.

The oil pump sucks lubricating oil from the oil pan through the oil strainer and the oil flows down to the filter cartridge, where it is further filtered.

Then the oil is force-fed to crankshaft, connecting

rods, idle gear, camshaft and rocker arm shaft to lubricate each part.

Some part of oil, splashed by the crankshaft or leaking and dropping from gaps of each part, lubricates these parts: pistons, cylinders, small ends of connecting rods, tappets, push rods, inlet and exhaust valves and timing gears.

■ Engine Oil Flow

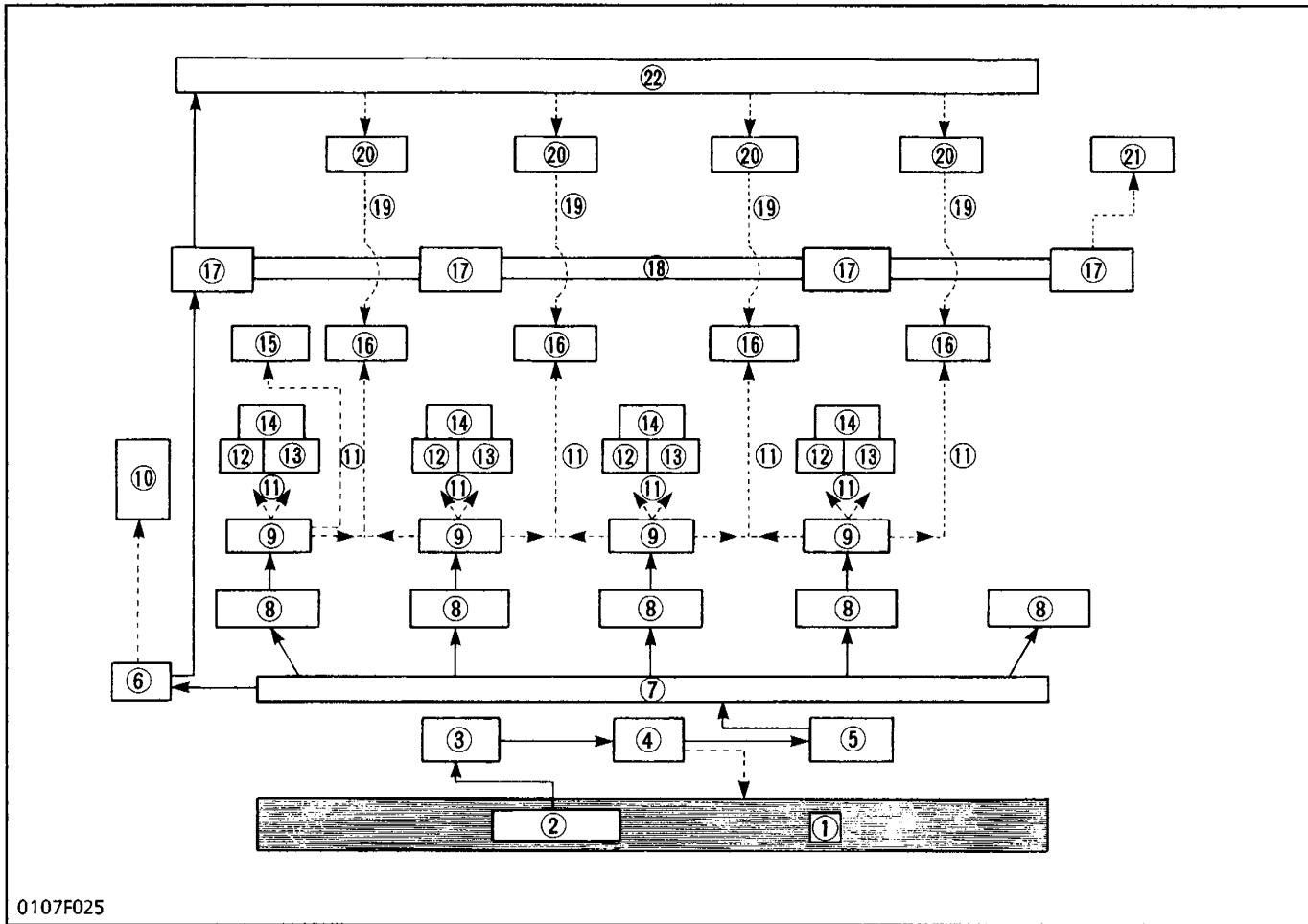

0107F025

- | | | | |
|--------------------------|----------------------|-----------------------|-----------------------|
| (1) Oil Pan | (7) Main Oil Gallery | (13) Small End | (19) Drain |
| (2) Oil Strainer | (8) Main Bearing | (14) Piston | (20) Rocker Arm |
| (3) Oil Pump | (9) Big End | (15) Fuel Camshaft | (21) Oil Switch |
| (4) Relief Valve | (10) Timing Gear | (16) Tappets | (22) Rocker Arm Shaft |
| (5) Oil Filter Cartridge | (11) Splash | (17) Camshaft Bearing | |
| (6) Idle Gear | (12) Bore | (18) Camshaft | |

(1) Relief Valve

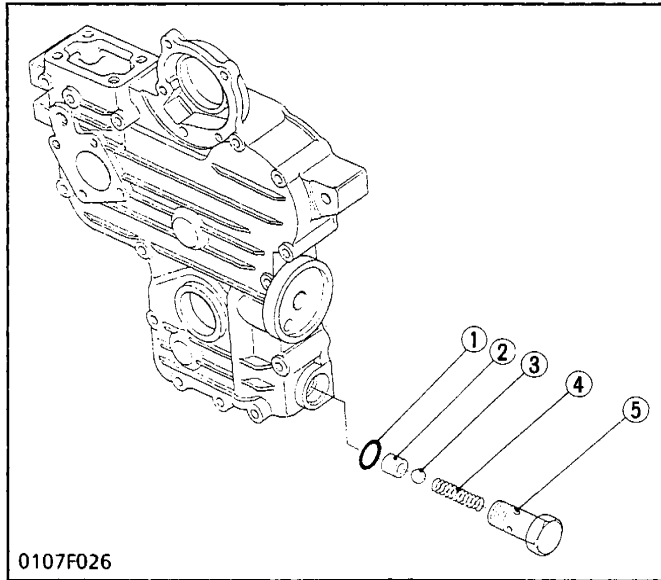

The relief valve prevents damage to the lubricating system due to high oil pressure. This relief valve is a ball type direct acting relief valve, and is best suited for low pressures. When oil pressure exceeds the upper limit, the ball (3) is pushed back by the pressure oil and the oil escapes.

Valve opening pressure at rated speed	441 to 490 kPa 4.5 to 5.0 kgf/cm ² 64 to 71 psi
---------------------------------------	--

- (1) O-ring
- (2) Valve Seat
- (3) Steel Ball
- (4) Spring
- (5) Relief Valve Body

(2) Oil Filter Cartridge

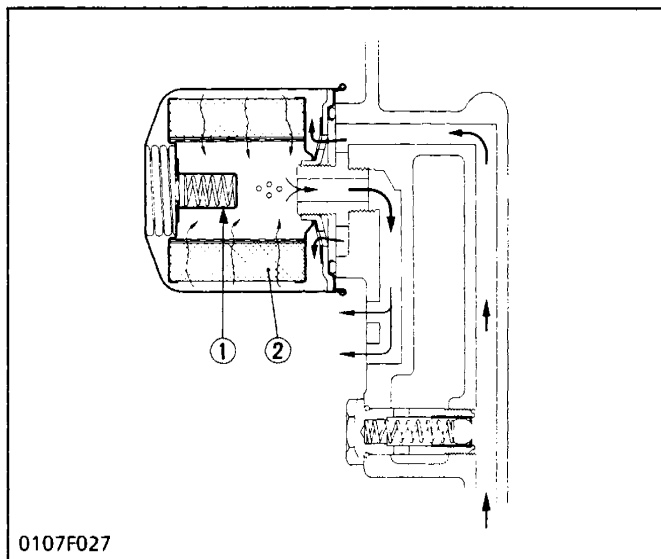

Impurities (various metallic chips, and dust, carbon, etc. in the sucked air) in engine oil can cause to wear and seize components as well as impairing the physical and chemical properties of the oil itself. Impurities contained in force-fed engine oil are absorbed on the filter paper for removal as they pass through the filter element (2).

When the filter element is clogged and the oil pressure in inlet line builds up by 98 kPa (1.0 kgf/cm², 14 psi) more than the outlet line, the bypass valve (1) opens and the oil flows from inlet to outlet bypassing the filter element.

- (1) Bypass Valve
- (2) Filter Element

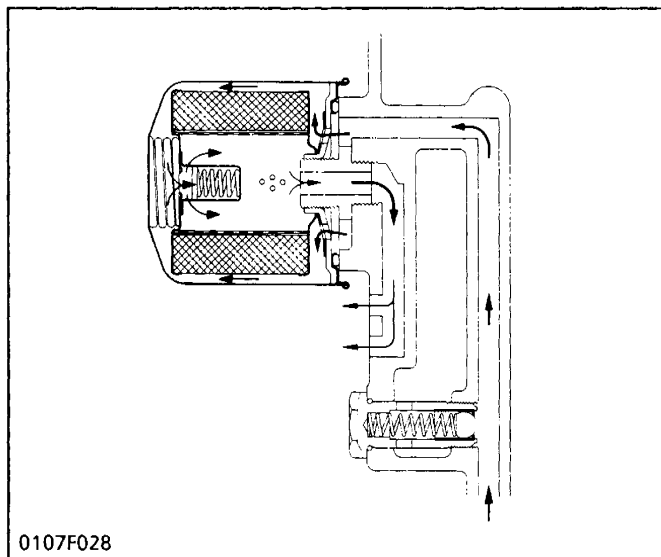

(3) Oil Switch

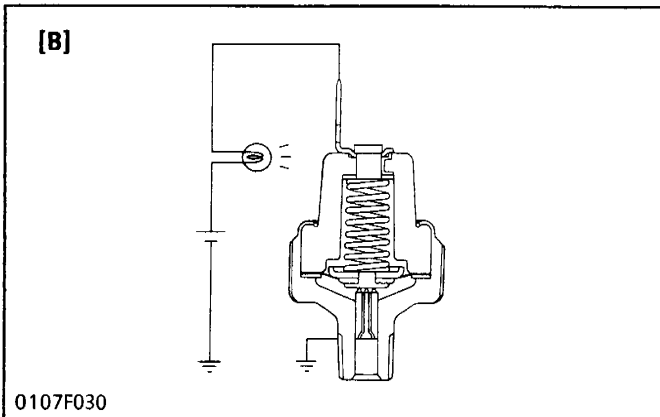
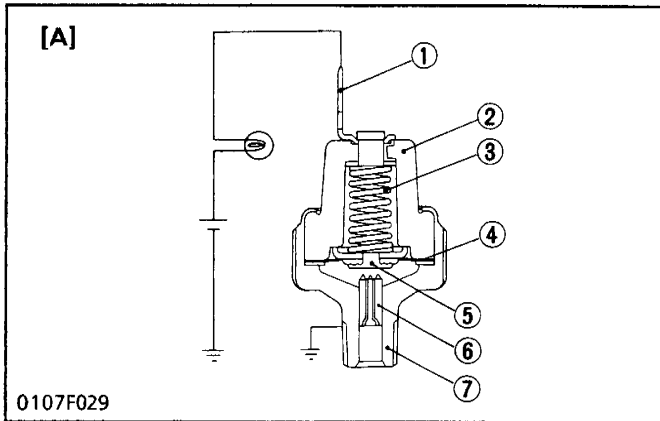

The oil switch is mounted on the crankcase, to warn the operator that the lubricating oil pressure is poor.

If the oil pressure falls below 49 kPa (0.5 kgf/cm², 7 psi), the oil warning lamp will light up, warning the operator. In this case, stop the engine immediately and check the cause of pressure drop.

- [A] At Proper Oil Pressure**
[B] At Oil Pressures of 49 kPa (0.5 kgf/cm², 7 psi) or Less
- (1) Terminal
 - (2) Insulator
 - (3) Spring
 - (4) Rubber Gasket
 - (5) Contact Rivet
 - (6) Contact
 - (7) Oil Switch Body

(4) Oil Pump

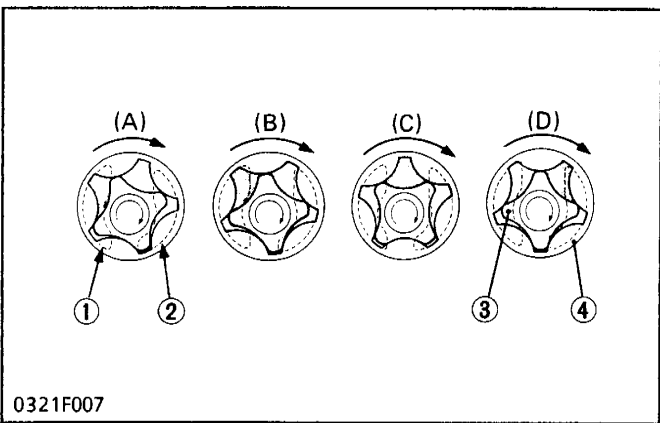

- (1) Inlet
- (2) Outlet
- (3) Inner Rotor
- (4) Outer Rotor

The oil pump in this engine is a trochoid pump.

Inside the pump body, the 4 lobe inner rotor (3) is eccentrically engaged with the 5 lobe outer rotor (4).

The inner rotor is driven by the crankshaft via gears, which in turn rotate the outer rotor.

When the inner rotor rotates, the outer rotor also rotates in the same direction.

The two rotors have differences in lobe number and center which generates space between lobes as shown in the figure. At position (A), there is little space between lobes in the inlet port. As the rotor rotates towards position (B), the space between the lobes becomes larger, creating a negative pressure which sucks in oil.

Outside the inlet port, as shown in position (C), the space between the lobes becomes gradually smaller, and oil pressure increases. At position (D), oil is discharged from the outlet port.

[3] COOLING SYSTEM

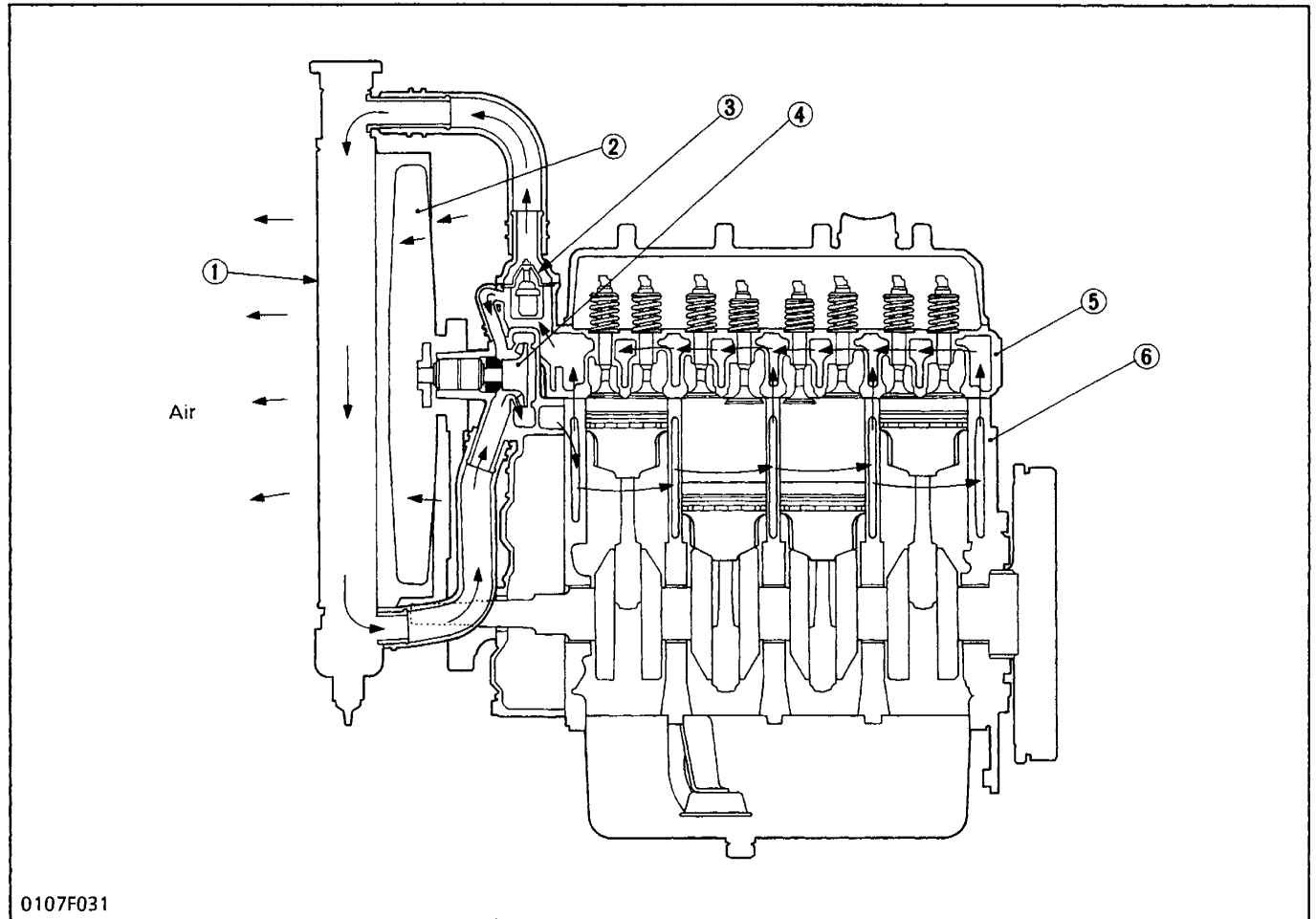

0107F031

(1) Radiator
(2) Cooling Fan

(3) Thermostat
(4) Water Pump

(5) Cylinder Head

(6) Cylinder Block

The cooling system consists of a radiator (1), centrifugal water pump (4), cooling fan (2) and thermostat (3).

The water is cooled through the radiator core, and the fan set behind the radiator blows cooling air through the core to improve cooling.

The water pump sucks the cooled water, forces it into the cylinder block and draws out the hot water.

Then the cooling is repeated. Furthermore, to control temperature of water, a thermostat is provided in the system. When the thermostat opens, the water moves directly to radiator, but when it closes, the water moves toward the water pump through the bypass between thermostat and water pump. The opening temperature of thermostat is approx. 82°C (180°F).

(1) Water Pump

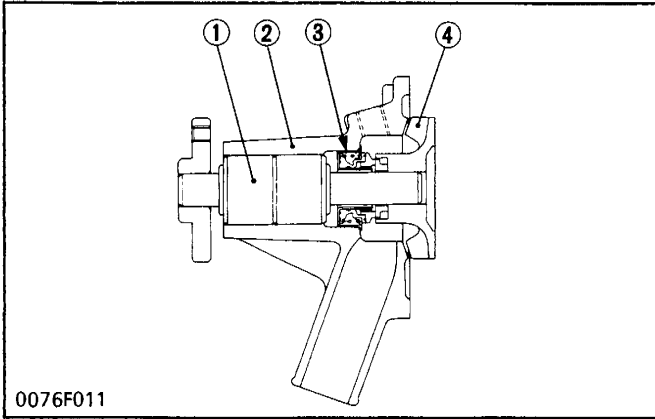

The water pump is driven by the crankshaft via a V belt. Water cooled in the radiator is sucked into the water pump from its lower portion and is sent from the center of the water pump impeller (4) radially outward into the water jacket in the crankcase. The bearing unit (1) prevents cooling water from entering by a mechanical seal (3).

- (1) Bearing Unit
- (2) Water Pump Body
- (3) Mechanical Seal
- (4) Water Pump Impeller

(2) Thermostat

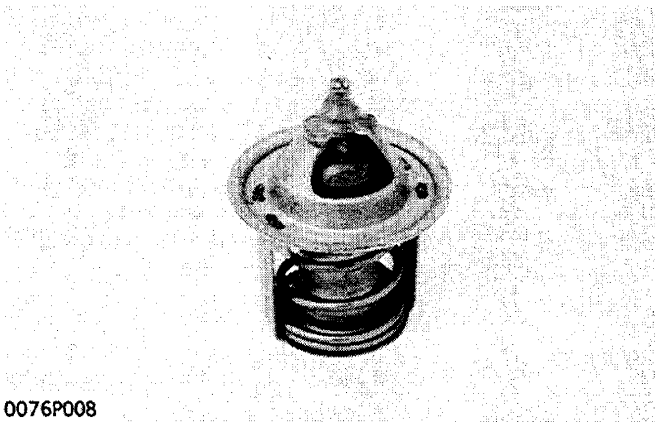

The thermostat maintains the cooling water at correct temperature. KUBOTA's engine uses a wax pellet type thermostat. Wax is enclosed in the pellet. The wax is solid at low temperatures, but turns liquid at high temperatures, expands and opens the valve.

- a) At low temperatures (lower than 82°C (180°F)).
As the thermostat is closed, cooling water circulates in the engine through the water return pipe without running to the radiator. Air in the water jacket escapes to the radiator side through leak hole (7) of the thermostat.
- b) At high temperatures (higher than 82°C (180°F)).
When the temperature of cooling water exceeds 82°C (180°F), wax in the pellet turns liquid and expands. Because the spindle (4) is fixed, the pellet (3) is lowered, the valve (2) is separated from the seat (1), and then cooling water is sent to the radiator.

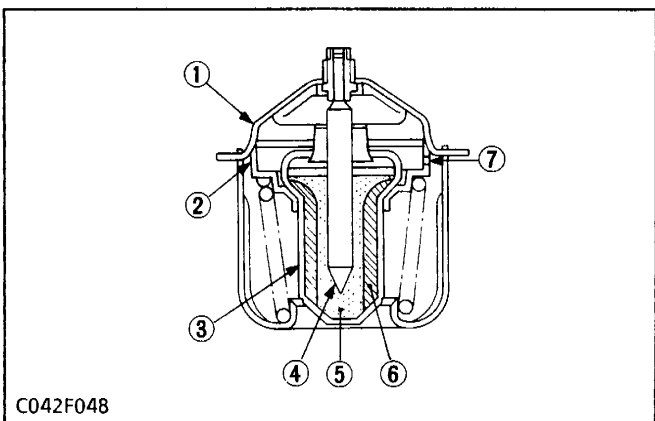

- (1) Seat
- (2) Valve
- (3) Pellet
- (4) Spindle
- (5) Synthetic Rubber
- (6) Wax (solid)
- (7) Leak Hole

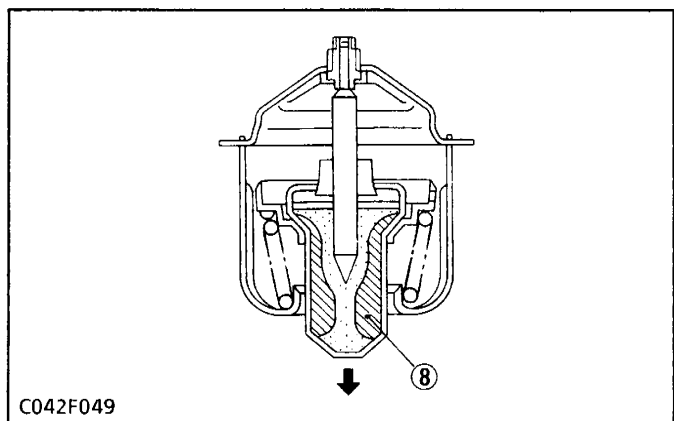

(3) Radiator

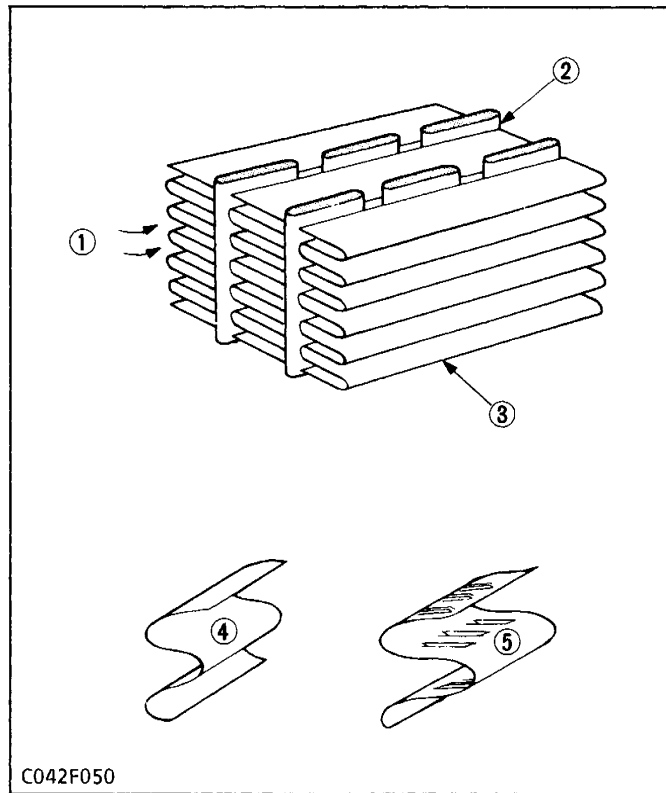

The radiator core consists of water carrying tubes and fins (3) at a right angle to the tubes (2). Heat of hot water in the tubes is radiated from the tube walls and fins. KUBOTA's engine uses corrugated fin type core which has a light weight and high heat transfer rate. Clogging is minimized by the louverless corrugated fins.

- (1) Cooling Air
- (2) Tube
- (3) Fin
- (4) Louverless Corrugated Fin
- (5) Louvered Corrugated Fin

(4) Radiator Cap

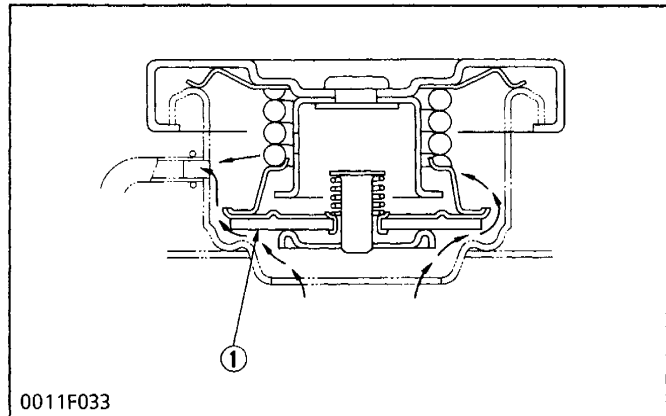

The radiator cap is of the pressure type, which opens the pressure valve (1) to reduce internal pressure when internal pressure is increased beyond a certain point due to increase in water temperature. The normal valve actuating pressure of the radiator cap is 88 kPa (0.9 kgf/cm², 13 psi).

When water temperature is reduced (and its volume is reduced), pressure in the radiator becomes negative, and the vacuum valve (2) opens and introduces air into the radiator to prevent distortion of the radiator.

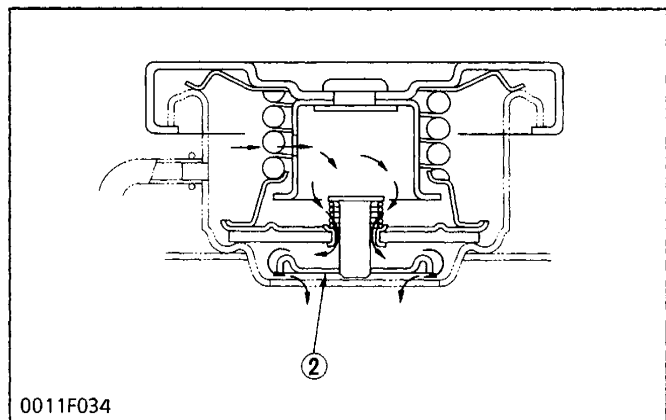

- (1) Pressure Valve
- (2) Vacuum Valve

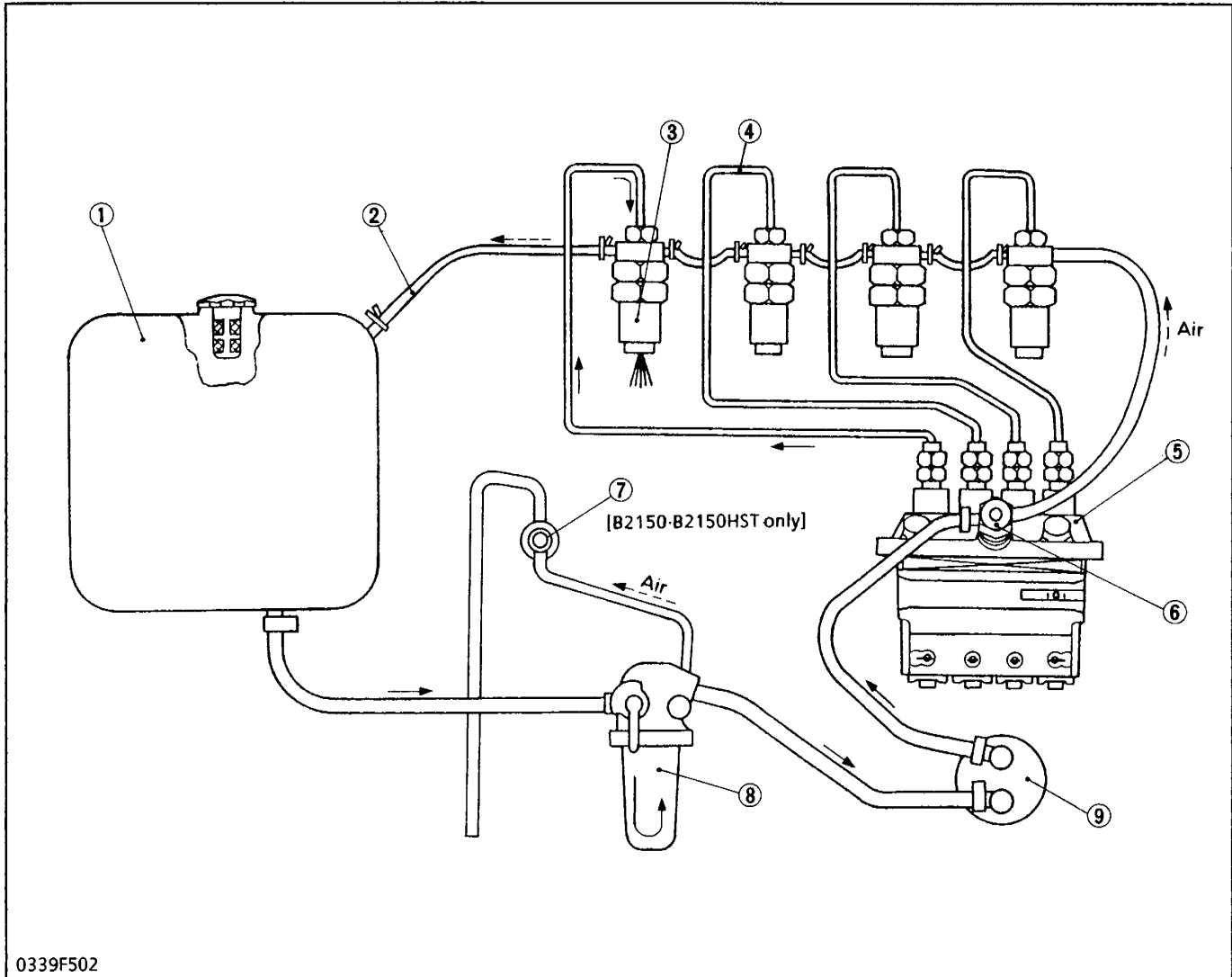
[4] FUEL SYSTEM

- | | | | | |
|------------------------|----------------------|--------------------|-------------------|--------------------|
| (1) Fuel Tank | (3) Injection Nozzle | (5) Injection Pump | (7) Air Vent Cock | (9) Fuel Lift Pump |
| (2) Fuel Overflow Pipe | (4) Injection Pipe | (6) Air Vent Cock | (8) Fuel Filter | |

While the engine is running, fuel is fed from the fuel tank (1) through the fuel filter (8) to the fuel lift pump (9), which feeds fuel to the injection pump (5). The injection pump then feeds the fuel through the injection pipes (4), to the nozzles (3) which inject fuel

to the cylinders for combustion. Any fuel leaking from nozzles is collected in the fuel overflow pipes (2) which drain into tank.

Air in the fuel system can be bled by loosening the air vent cock (6), (7) and by starting the engine.

(1) Fuel Filter

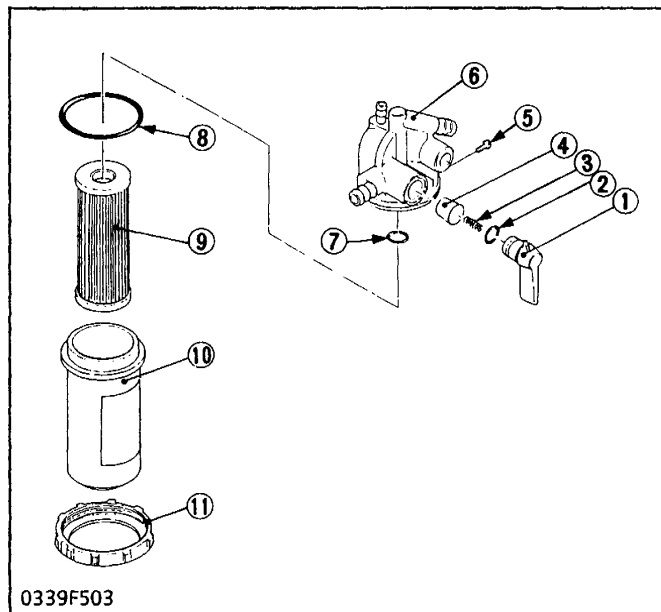

0339F503

The fuel filter is installed between the fuel tank and fuel lift pump, and serves to remove dirt and impurities from the fuel.

Fuel from the fuel tank enters the outside of the filter element (9) and passes through the filter element under its own pressure. As it passes through, the dirt and impurities in the fuel are filtered out, allowing only clean fuel to enter the interior of the filter element. The fuel exits from the outlet of the cock body (6) and is sent to the fuel lift pump.

Type of filter element	Accordion-pleated paper type
Material of filter element	Cotton fiber
Filter mesh	10 to 20 μm 400 to 800 μin.

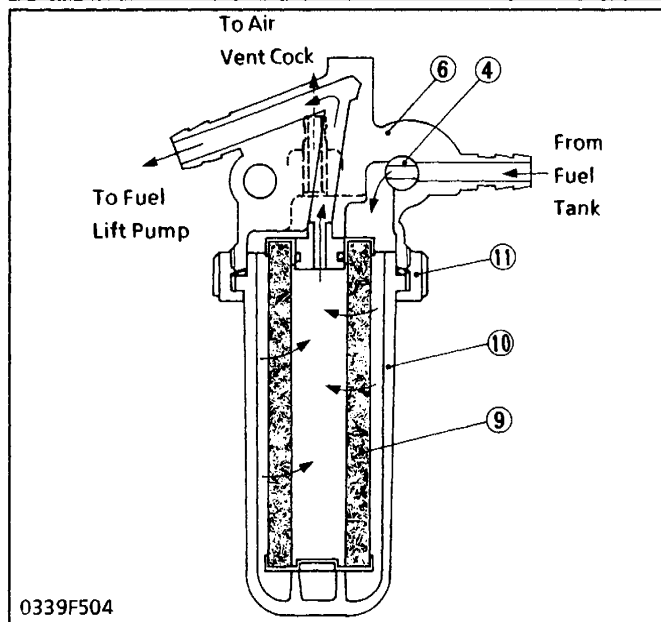

0339F504

- (1) Fuel Cock
- (2) O-ring
- (3) Spring
- (4) Taper Valve
- (5) Lever Screw
- (6) Cock Body
- (7) O-ring
- (8) O-ring
- (9) Filter Element
- (10) Filter Cup
- (11) Screw Ring

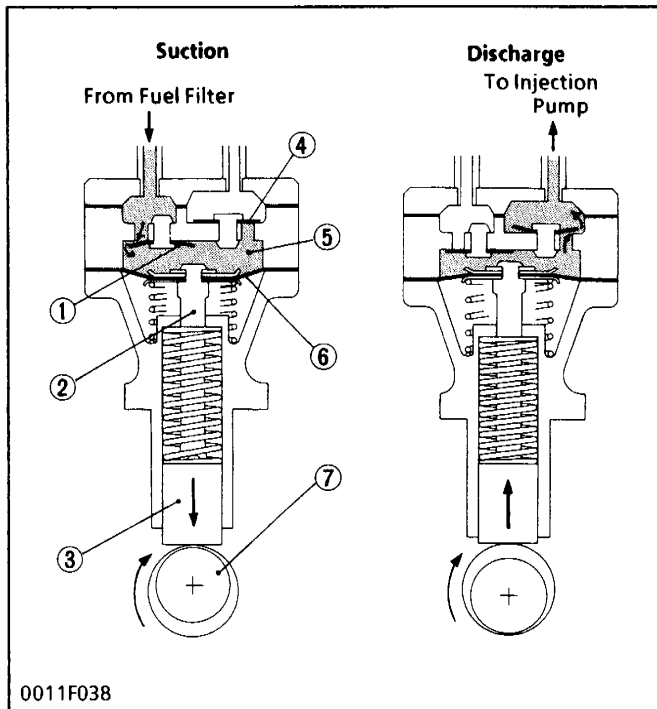
(2) Fuel Lift Pump

0011F038

- | | |
|------------------|-------------------|
| (1) Inlet Valve | (5) Chamber |
| (2) Pull Rod | (6) Diaphragm |
| (3) Tappet | (7) Fuel Camshaft |
| (4) Outlet Valve | |

Filtered fuel is fed to the injection pump by the fuel lift pump. The fuel lift pump operates as shown in the figure. Power is applied to the tappet (3) by an eccentric movement on the fuel camshaft (7). As the fuel camshaft rotates, the eccentric movement causes the tappet to move up and down. The tappet is linked to a flexible diaphragm (6) via the pull rod (2).

When the diaphragm is pulled down, a low vacuum or low pressure area is created above the diaphragm. This causes atmospheric pressure in the fuel tank to force fuel into the fuel lift pump. The inlet valve (1) opens to admit fuel into the chamber (5).

When the diaphragm is pushed up, pressure is created in the area above the diaphragm. This pressure closes the inlet valve and opens the outlet valve (4), forcing fuel from the pump through the fuel pipe to the injection pump.

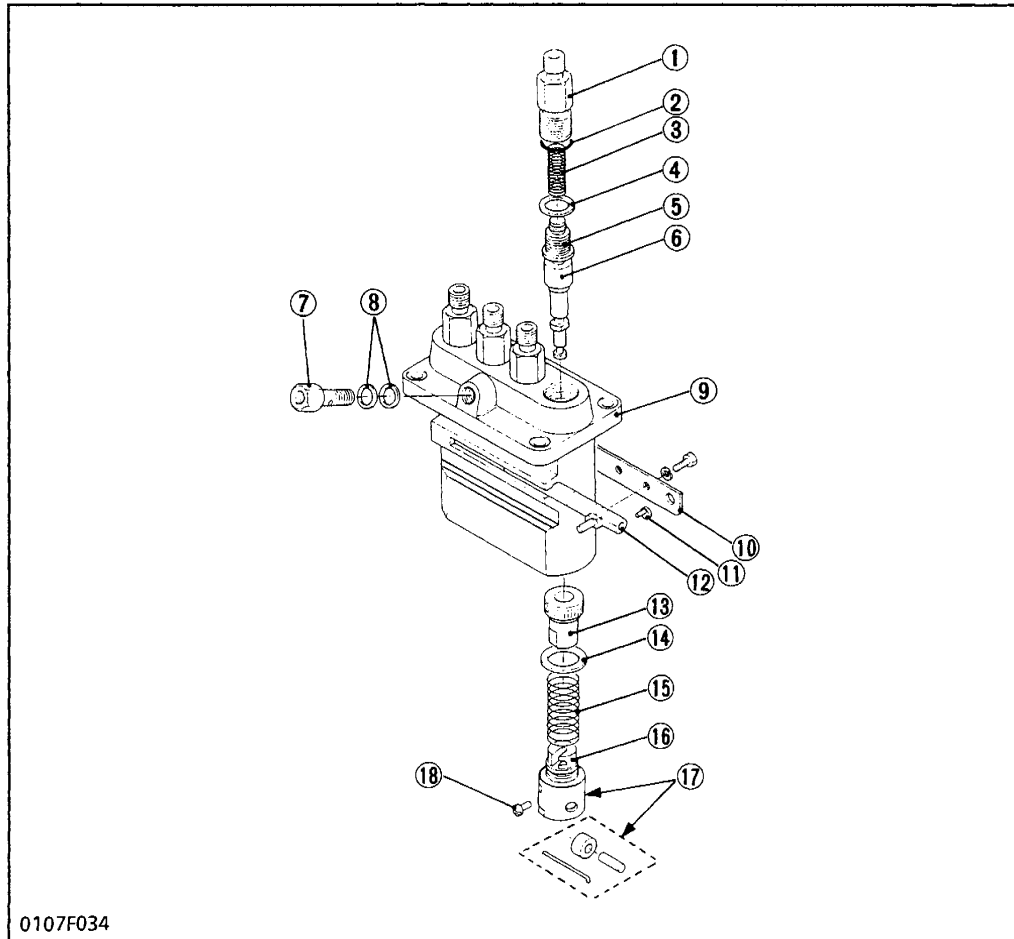
(3) Fuel Injection Pump

- (1) Delivery Valve Holder
- (2) O-ring
- (3) Delivery Valve Spring
- (4) Delivery Valve Gasket
- (5) Delivery Valve
- (6) Pump Element
- (7) Screw
- (8) Gaskets
- (9) Injection Pump Assembly
- (10) Adjusting Plate
- (11) Collar
- (12) Control Rack
- (13) Control Sleeve
- (14) Spring Upper Seat
- (15) Plunger Spring
- (16) Spring Under Seat
- (17) Tappet Assembly
- (18) Tappet Guide Pin

0107F034

This engine uses a Bosch K type mini injection pump. It gives high injection quality even at low engine speed. The plunger has a right-hand lead. It is reciprocated by the fuel camshaft via the tappet (17), forcing the fuel into the injection nozzle.

The fuel in the fuel chamber is drawn into the delivery chamber when the plunger lowers. When the plunger rises, delivery valve (5) is pushed open to force into the injection nozzle.

The control rack (12) is actuated by the governor, and the control rack movement is transmitted to the control sleeve (13). As a result, the plunger rotates to vary the amount of fuel fed into the injection nozzle.

When the engine stop lever is turned to the stop position, the fuel is not pressurized, and is not injected since the feed hole meets with the control groove.

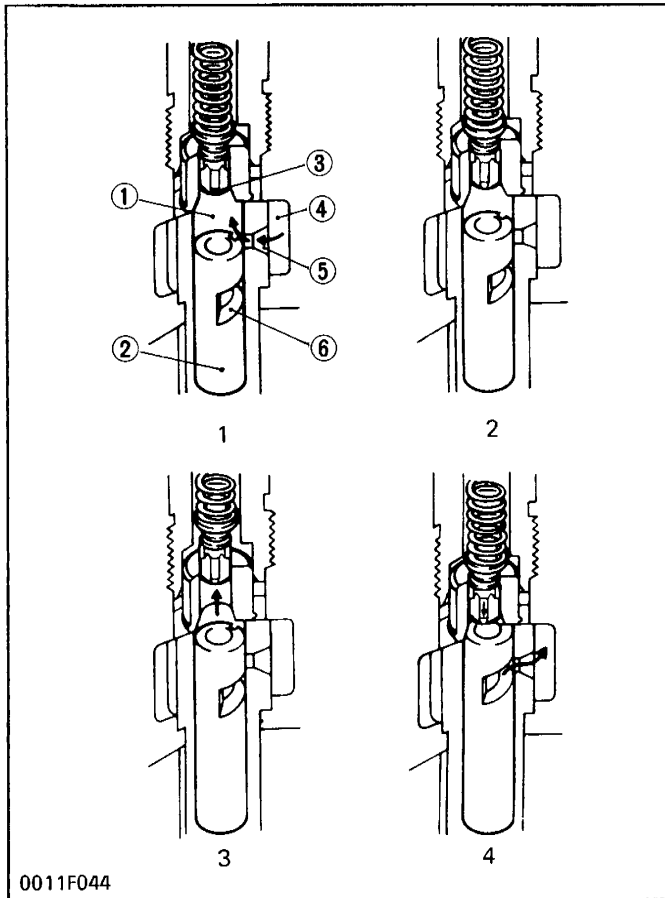

■ Operation of Pump Element

1. Before delivery

As the tappet lowers, the plunger (2) also lowers and fuel is drawn into the delivery chamber (1) through the feed hole (5) from the fuel chamber (4).

2. Beginning of delivery

When the plunger is pushed up by the rotation of the fuel camshaft and the head surface of the plunger closes the feed hole, the pressure in the delivery chamber rises to push the relief plunger (3) open.

Fuel is then force-fed toward the injection pipe.

3. Delivery

Delivery of fuel continues while the plunger is rising.

4. End of delivery

When the plunger rises further and the control groove (6) on its periphery meets the feed hole, the fuel returns to the fuel chamber from the delivery chamber through the control groove and the feed hole.

- | | |
|----------------------|--------------------|
| (1) Delivery Chamber | (4) Fuel Chamber |
| (2) Plunger | (5) Feed Hole |
| (3) Relief Plunger | (6) Control Groove |

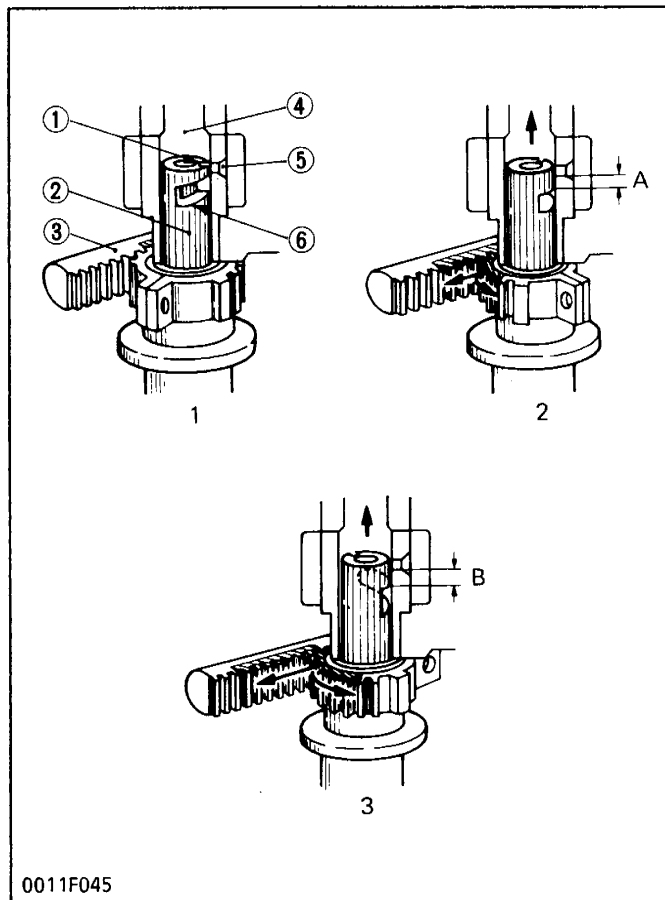

■ Plunger Position

1. No fuel delivery

When the control rack (3) is set at the engine stop position, the plunger (2) is rotated to a position where the vertical slot (1) of the plunger (2) aligns with the feed hole (5). Since the vertical slot prevents the feed hole from being covered, pressure in the delivery chamber (4) cannot build up. Therefore, no fuel can be forced to the injection nozzle.

2. Partial fuel delivery

When the plunger is rotated by the control rack in the direction of arrow, the fuel is delivered to the injection nozzle. The amount of fuel corresponds to the distance "A" from where the feed hole is closed by the plunger head, to where the control groove (6) meets the feed hole.

3. Maximum fuel delivery

Maximum fuel delivery occurs when the plunger is rotated to a position where the feed hole is covered by the plunger as it moves upward, for the greatest distance "B" permitted by the control rack.

- | | |
|-------------------|----------------------|
| (1) Vertical Slot | (4) Delivery Chamber |
| (2) Plunger | (5) Feed Hole |
| (3) Control Rack | (6) Control Groove |

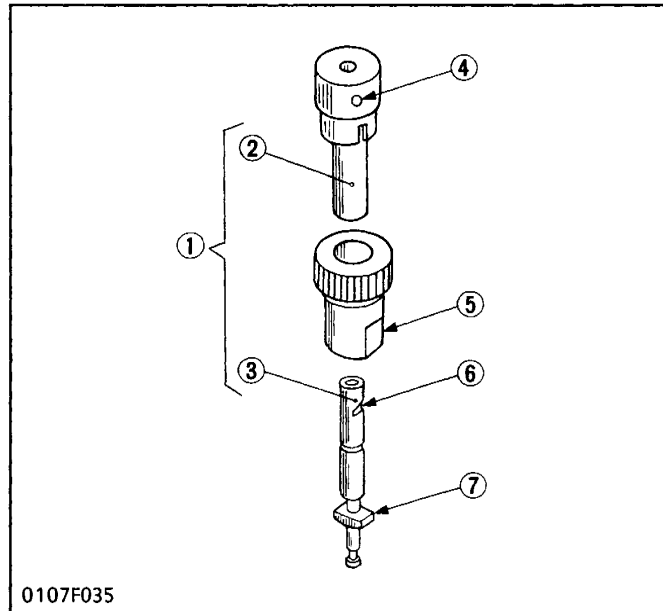

■ Pump Element

The pump element (1) consists of the plunger (3) and cylinder (2). Their sliding surfaces are super precision machined to maintain the injection pressure (approx. 13.73 MPa, 140 kgf/cm², 1991 psi) at idle speed.

Since the driving face (7) fits in the control sleeve (5), the plunger is rotated by the movement of the control rack. The cylindrical surface of the plunger has a helix groove, which is called the control groove (6).

- (1) Pump Element
- (2) Cylinder
- (3) Plunger
- (4) Feed Hole
- (5) Control Sleeve
- (6) Control Groove
- (7) Driving Face

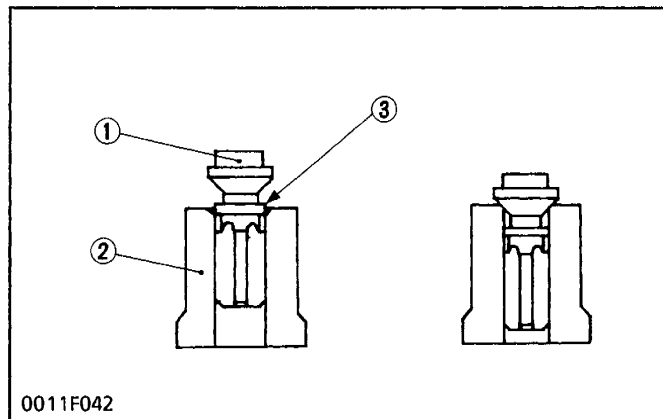

- (1) Valve
- (2) Valve Seat

- (3) Relief Plunger

■ Delivery Valve

The delivery valve consists of the valve (1) and valve seat (2). The delivery valve prevents the fuel in the injection pipe from flowing backward toward the delivery chamber side and also serves to suck back the fuel to prevent dribbling at the injection nozzle.

When the delivery stroke ends and the valve starts to resume its seated position, the relief plunger (3) will move into the bore of the valve seat, thus sealing the delivery line from the delivery chamber. After the relief plunger has entered the bore of the valve seat, the valve seats firmly. Now the space for fuel in the delivery line is increased by an amount equal to the volume of the relief plunger. The effect of this increase in volume is a sudden pressure drop in the delivery line, causing the injection nozzle to close instantly, thus preventing backward dribbling.

(4) Injection Nozzle

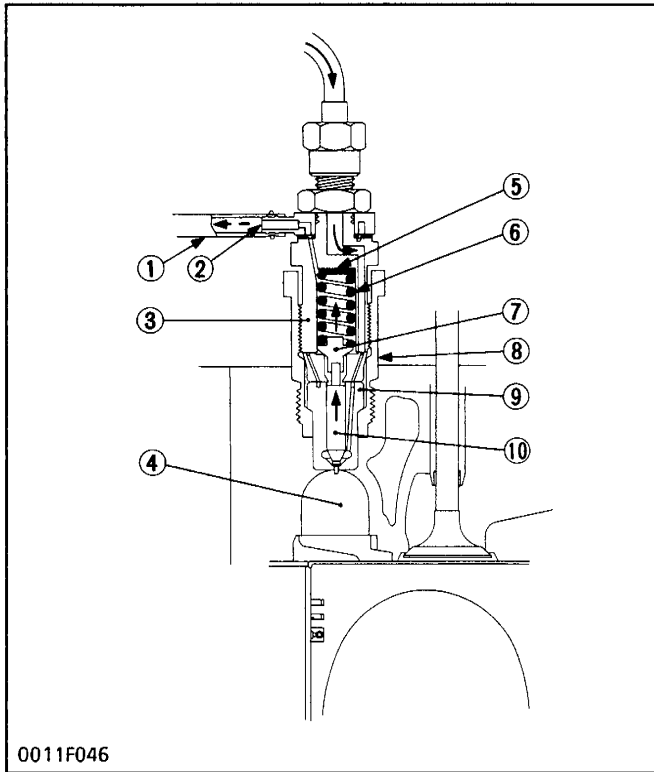

This nozzle is throttle-type. The needle valve (10) is pushed against the nozzle body (9) by the nozzle spring (6) via the push rod (7). Fuel pressurized by the injection pump pushes the needle valve up and then is injected into the sub-combustion chamber (4).

Fuel lubricating the needle valve (10) and nozzle body (9) drains through the eye joint (2) and the fuel overflow pipe (1) to the fuel tank.

The injection pressure is 13.73 to 14.71 MPa (140 to 150 kgf/cm², 1991 to 2133 psi), and is adjusted with adjusting washer (5).

- (1) Fuel Overflow Pipe
- (2) Eye Joint
- (3) Nozzle Holder Body
- (4) Sub-combustion Chamber
- (5) Adjusting Washer
- (6) Nozzle Spring
- (7) Push Rod
- (8) Retaining Nut
- (9) Nozzle Body
- (10) Needle Valve

(5) Governor

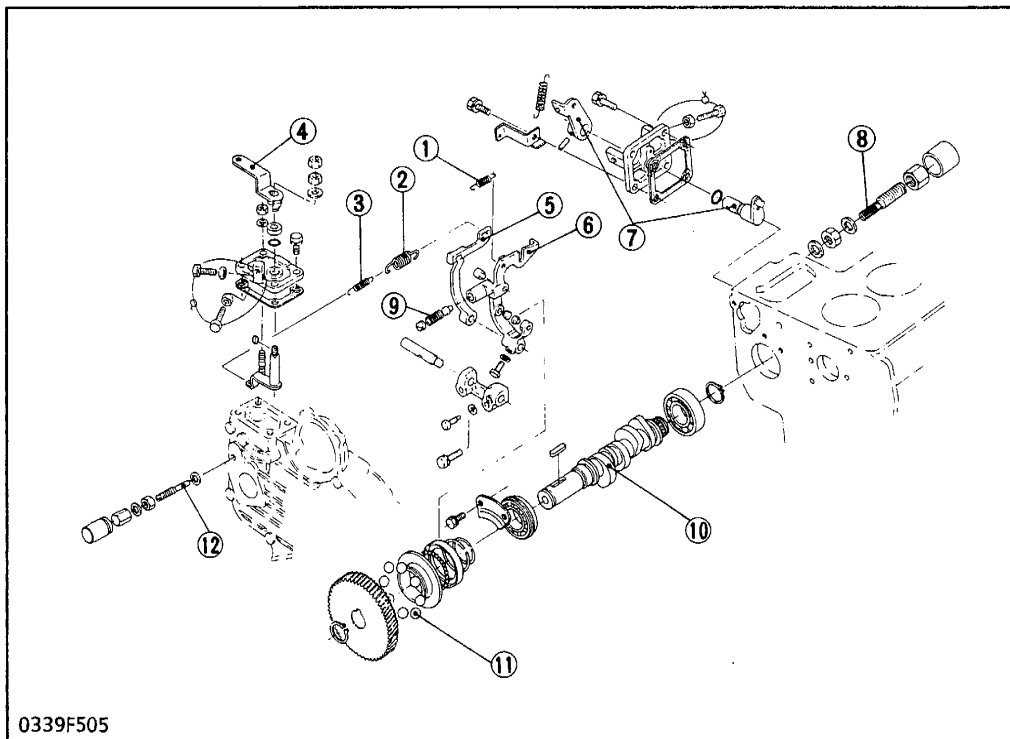

- (1) Start Spring
- (2) Governor Spring 1
- (3) Governor Spring 2
- (4) Speed Control Lever
- (5) Fork Lever 2
- (6) Fork Lever 1
- (7) Stop Lever
- (8) Idling Limit Spring
- (9) Torque Spring
- (10) Fuel Camshaft
- (11) Steel Ball
- (12) Fuel Limit Adjusting Screw

The governor serves to keep engine speed constant by automatically adjusting the amount of fuel supplied to the engine according to changes in the load. This engine employs an all-speed governor

which controls the centrifugal force of the steel balls (11) weight, produced by rotation of the fuel camshaft (10), and the load of the governor spring 1 (2) and 2 (3) are balanced.

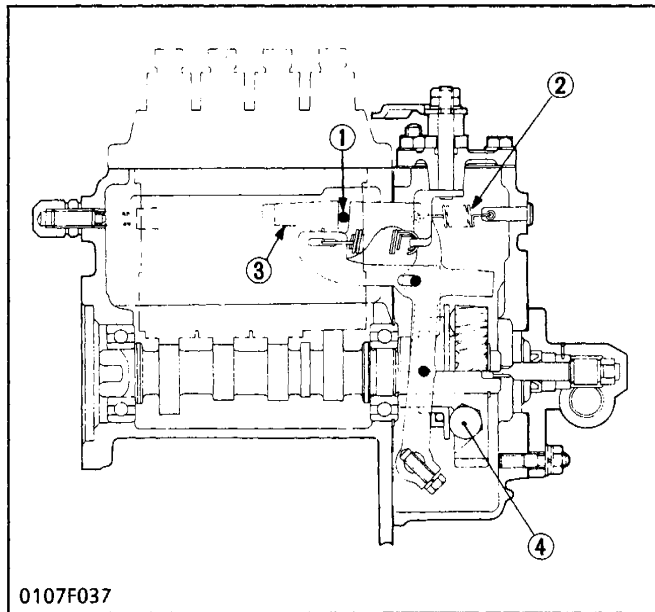

- | | |
|------------------|------------------|
| (1) Control Rack | (3) Fork Lever 1 |
| (2) Start Spring | (4) Steel Ball |

■ At Start

Since the steel balls (4) have no centrifugal force, a fork lever 1 (3) is pulled to the right by the start spring (2). Accordingly, the control rack (1) moves to the maximum injection position to assure easy starting.

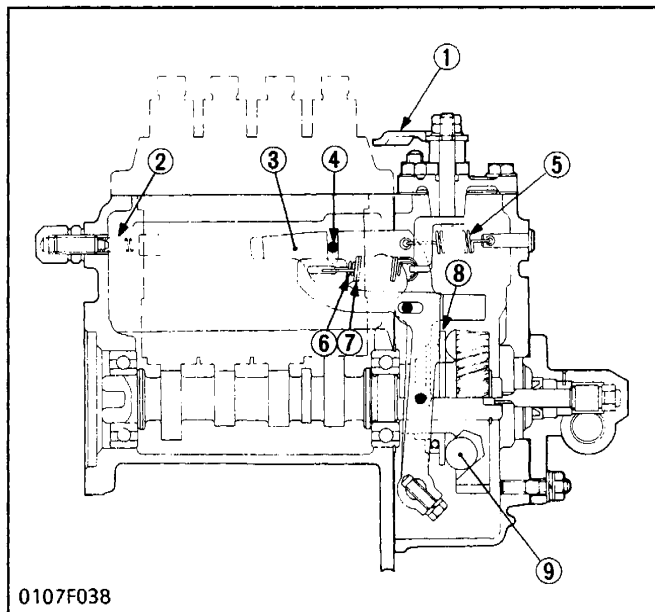

- | | |
|-------------------------|-----------------------|
| (1) Speed Control Lever | (6) Governor Spring 2 |
| (2) Idling Limit Spring | (7) Governor Spring 1 |
| (3) Fork Lever 1 | (8) Governor Sleeve |
| (4) Control Rack | (9) Steel Ball |
| (5) Start Spring | |

■ At Idling

When the speed control lever (1) is set at the idling position after the engine starts, the governor spring 1 (7) does not work at all and the governor spring 2 (6) does only act slightly. The governor sleeve (8) is pushed leftward by a centrifugal force of steel balls (9).

Therefore, the fork lever 1 (3) and control rack (4) are moved to the left by the governor sleeve (8) and then the idling limit spring (2) is compressed by the control rack (4). As a result, the control rack (4) is kept at a position where a centrifugal force of steel balls (9) and force of start spring (5), governor spring 2 (6) and idling limit spring (2) are balanced, providing stable idling.

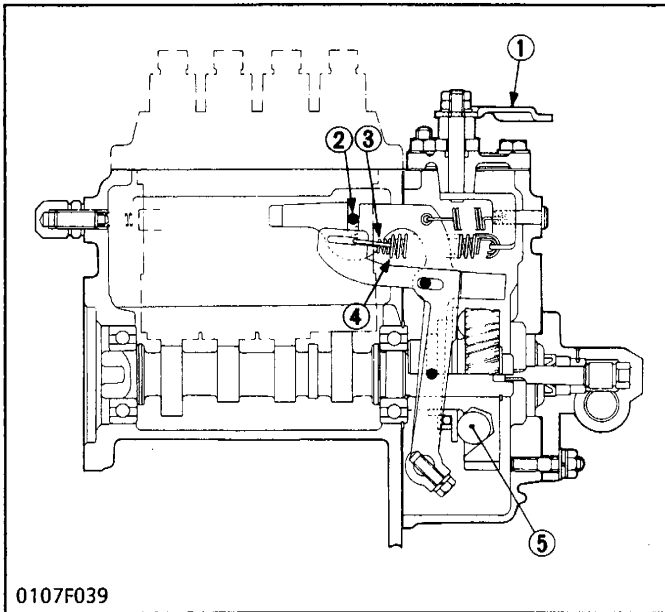

0107F039

■ At Medium or High Speed Running

The engine speed is controlled when the tension of governor springs 1 (4) and 2 (3), which are pulled by the speed control lever (1), and the centrifugal force of steel balls (5) are balanced.

When the engine speed is dropped (A→B) with load increased (a→b), the centrifugal force of steel balls becomes smaller than the tension of governor springs 1 and 2. As a result, the control rack (2) is moved to the right and amount of fuel injected is increased to produce an engine torque required for the load.

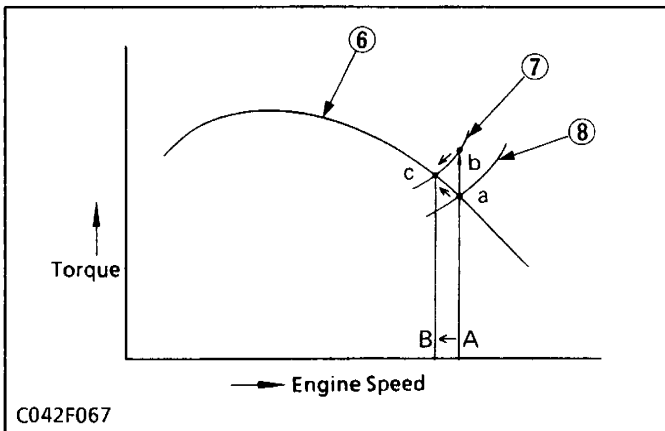

C042F067

- (1) Speed Control Lever
- (2) Control Rack
- (3) Governor Spring 2
- (4) Governor Spring 1
- (5) Steel Ball
- (6) Engine Torque Curve
- (7) Large Load Torque Curve
- (8) Small Load Torque Curve

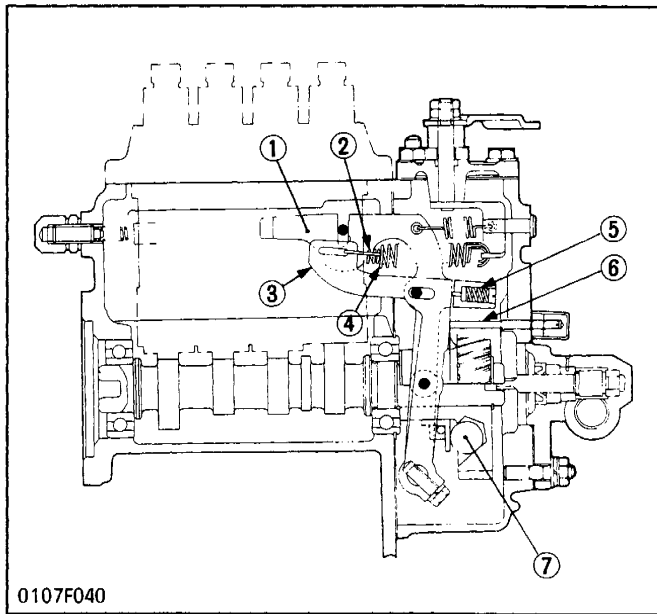

0107F040

- (1) Fork Lever 1
- (2) Governor Spring 2
- (3) Fork Lever 2
- (4) Governor Spring 1
- (5) Torque Spring
- (6) Adjusting Screw
- (7) Steel Ball

At High Speed Running with Overload

When an overload is applied to the engine running at a high speed, the centrifugal force of steel balls (7) becomes small as the engine speed is dropped, and fork lever 2 (3) is pulled to the right by the governor springs 1 (4) and 2 (2), increasing fuel injection. Though, fork lever 2 becomes ineffective in increasing fuel injection when it is stopped by the adjusting screw (6).

After that, when the force of torque spring (5) becomes greater than the centrifugal force of the steel balls, fork lever 1 (1) moves rightward to increase fuel injection, causing the engine to run continuously at a high torque.

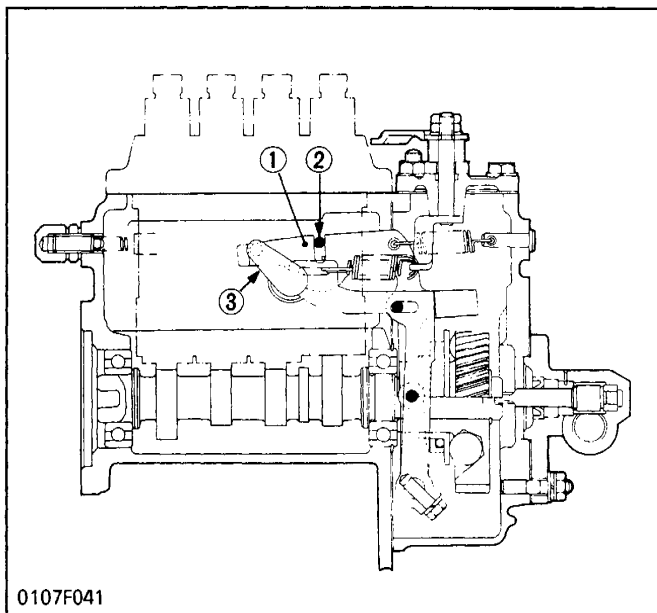

0107F041

- (1) Fork Lever 1
- (2) Control Rack
- (3) Stop Lever

To Stop Engine

When the stop lever (3) is moved to "STOP" position, fork lever 1 (1) is moved leftward and the control rack (2) is moved to the non-injection position, stopping the engine.

2 CLUTCH

The clutch is located between the engine and the transmission and is operated by stepping on the clutch pedal. When the clutch pedal is depressed, the

clutch is disengaged. And when it is released, the clutch is engaged and power from the engine is transmitted to the transmission.

[1] DRY TYPE, SINGLE PLATE CLUTCH (EXCEPT B2150)

■ B1550-B1750-B1550HST-B1750HST

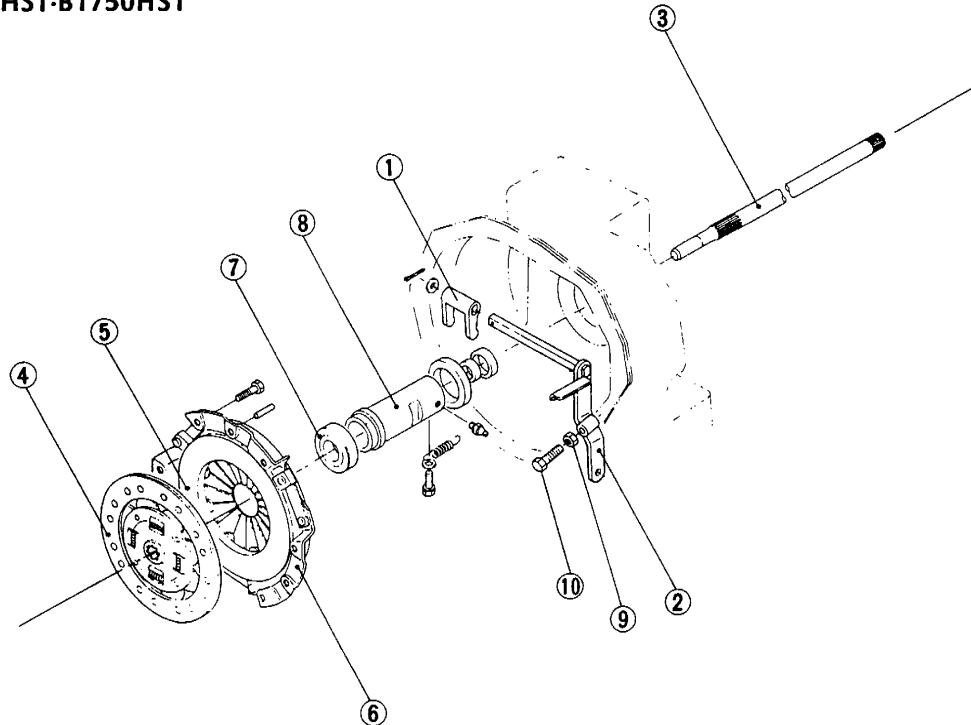

0354F002

■ B2150HST

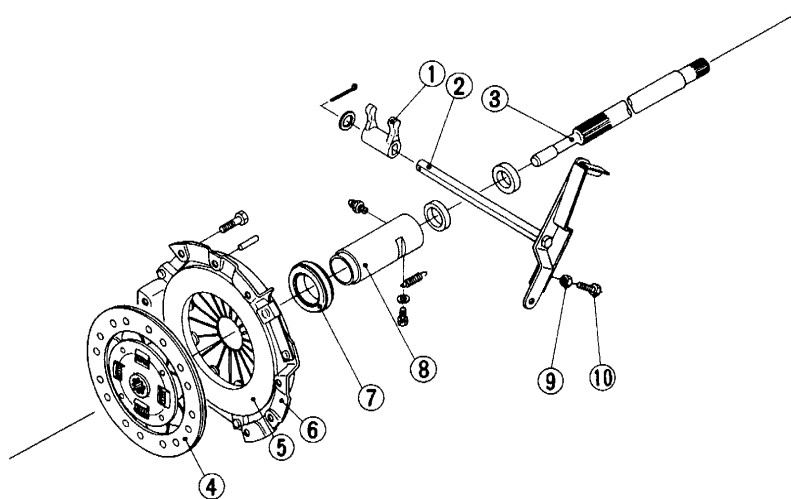

0302F006

- | | | | |
|-------------------------|--------------------------|----------------------------|----------------------------|
| (1) Clutch Release Fork | (4) Clutch Disc Assembly | (7) Clutch Release Bearing | (10) Clutch Adjusting Bolt |
| (2) Clutch Rod | (5) Pressure Plate | (8) Release Bearing Holder | |
| (3) Propeller Shaft | (6) Clutch Cover | (9) Lock Nut | |

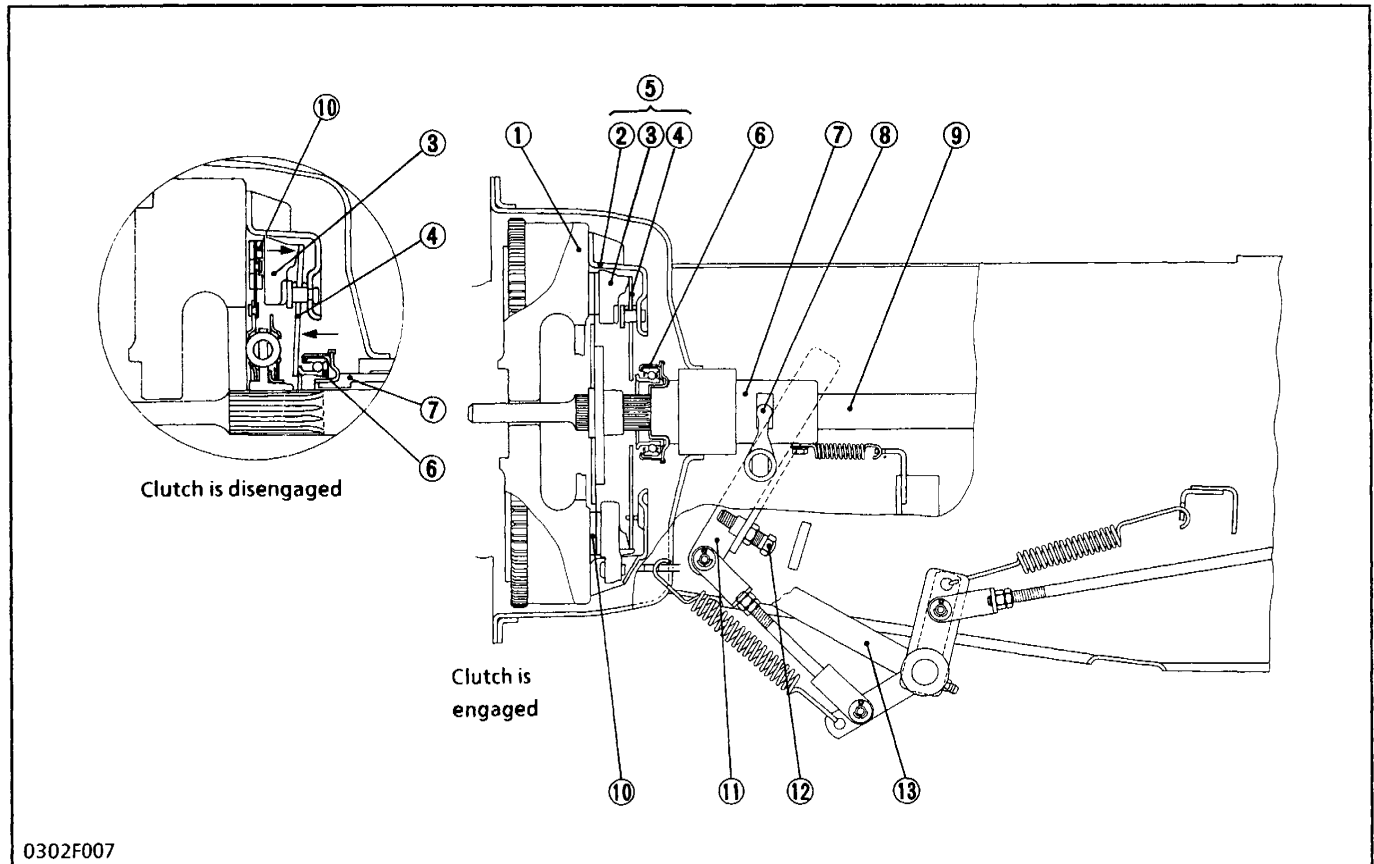

- | | | | |
|----------------------|-----------------------------|-------------------------|----------------------------|
| (1) Engine Flywheel | (5) Pressure Plate Assembly | (8) Clutch Release Fork | (11) Clutch Rod |
| (2) Clutch Cover | (6) Clutch Release Bearing | (9) Propeller Shaft | (12) Clutch Adjusting Bolt |
| (3) Pressure Plate | (7) Release Bearing Holder | (10) Clutch Disc | (13) Clutch Pedal |
| (4) Diaphragm Spring | | | |

Engine torque is transmitted to the pressure plate assembly (5) via the flywheel (1) which is connected to the engine crankshaft. Therefore, the clutch cover constantly runs with engine. The clutch disc (10) is located between the flywheel (1) and the pressure plate (3) of pressure plate assembly. Torque is transmitted to the clutch disc (10) by the pressure created by diaphragm spring (4) installed in pressure

plate assembly. Then, the torque is transmitted to the transmission via the propeller shaft (9).

When the pedal (13) is depressed, the release bearing holder (7) and the clutch release bearing (6) move towards the flywheel and push the fingers of the diaphragm spring (4). In other words, this movement pulls the pressure plate (3) up and disengages the clutch.

[2] DRY TYPE, DUAL STAGE CLUTCH (B2150)

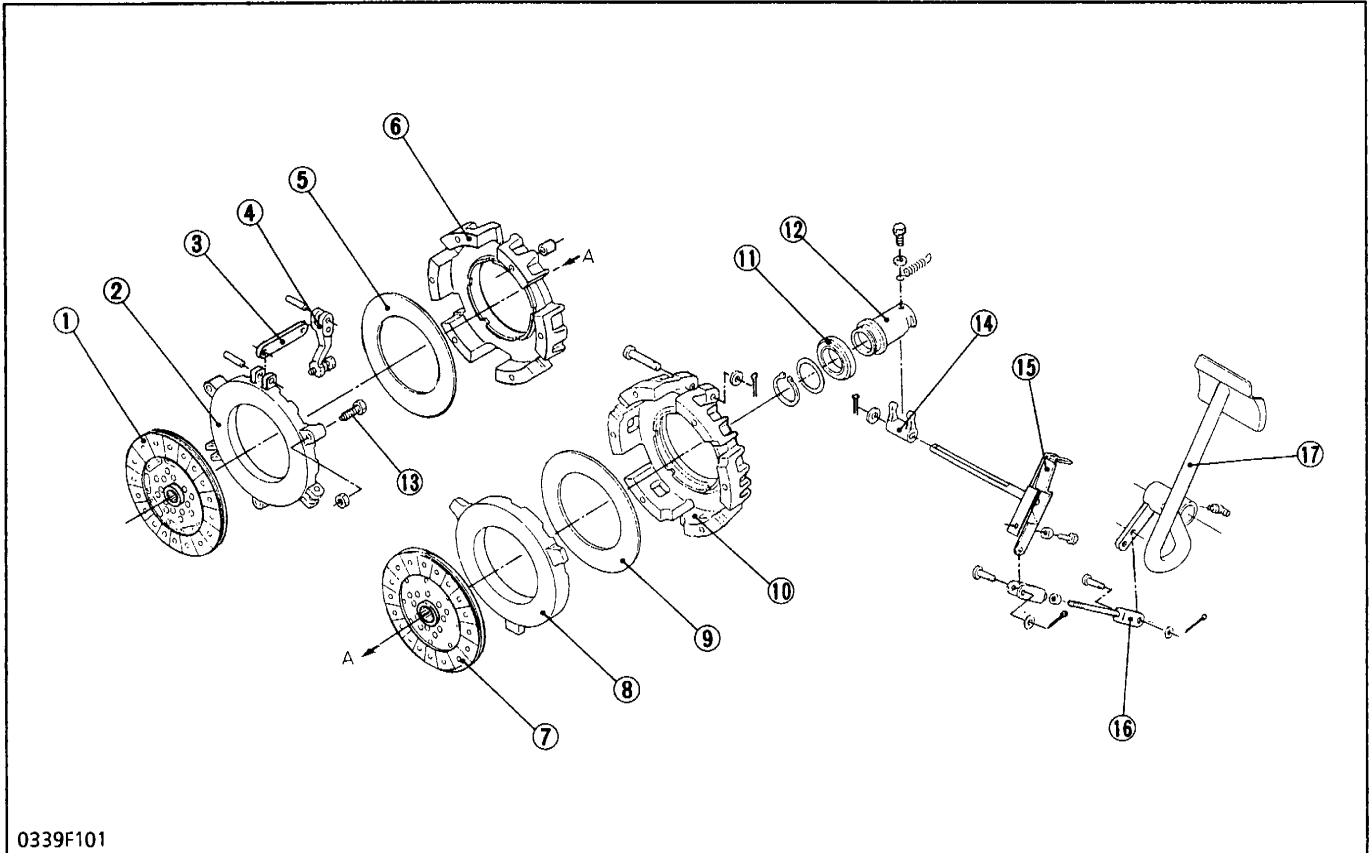

0339F101

- | | | | |
|-----------------------------|-----------------------|-----------------------------|-------------------|
| (1) Clutch Disc (Traveling) | (6) Clutch Cover | (10) Clutch Cover | (14) Release Fork |
| (2) Pressure Plate | (7) Clutch Disc (PTO) | (11) Release Bearing | (15) Clutch Rod |
| (3) Release Rod | (8) Pressure Plate | (12) Release Bearing Holder | (16) Clutch Rod |
| (4) Release Lever | (9) Belleville | (13) Adjusting Bolt | (17) Clutch Pedal |
| (5) Belleville | | | |

A dual stage clutch is a combination of single plate clutches. One clutch control power flow from the

engine to the transmission for traveling, and the other controls that for PTO.

■ Travelling Clutch and PTO Clutch "Engaged"

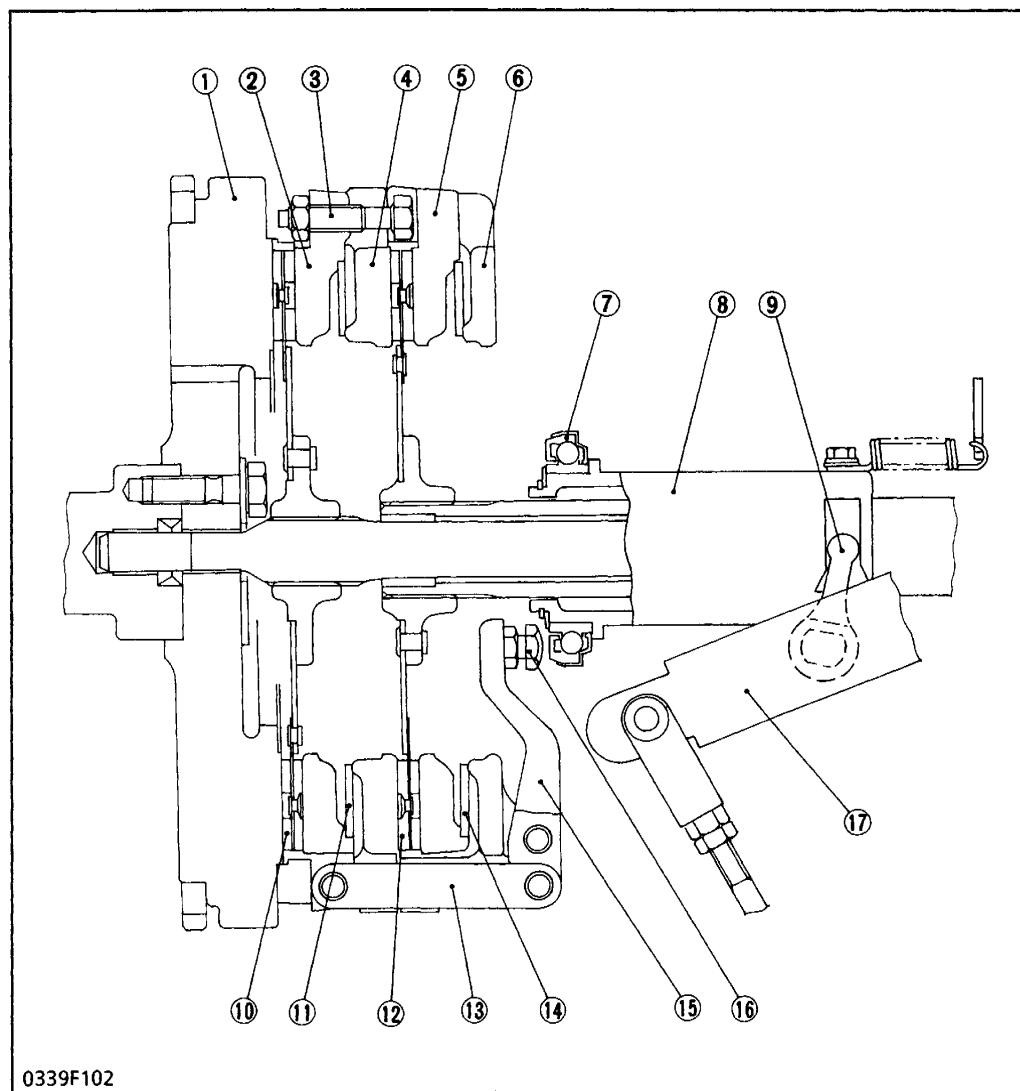

- (1) Flywheel
- (2) Pressure Plate (Travelling)
- (3) Adjusting Screw
- (4) Clutch Cover
- (5) Pressure Plate (PTO)
- (6) Clutch Cover
- (7) Release Bearing
- (8) Release Bearing Holder
- (9) Release Fork
- (10) Clutch Disc (Travelling)
- (11) Belleville Spring
- (12) Clutch Disc (PTO)
- (13) Release Rod
- (14) Belleville Spring
- (15) Release Lever
- (16) Adjusting Screw
- (17) Clutch Rod

0339F102

When the clutch pedal is not depressed, there is a certain amount of clearance between the release bearing (7) and the adjusting screw (16) mounted on the release lever (15). Under the conditions above;

- The travelling clutch disc (10) is pressed between the flywheel (1) and the pressure plate (2) by the force of the Belleville spring (11).
- The PTO clutch disc (12) is pressed between the clutch cover (4) and the pressure plate (5) by the force of the Belleville spring (14).

Thus, the rotation of flywheel is transmitted to both the travelling and PTO systems.

■ Traveling Clutch "Disengaged", PTO Clutch "Engaged"

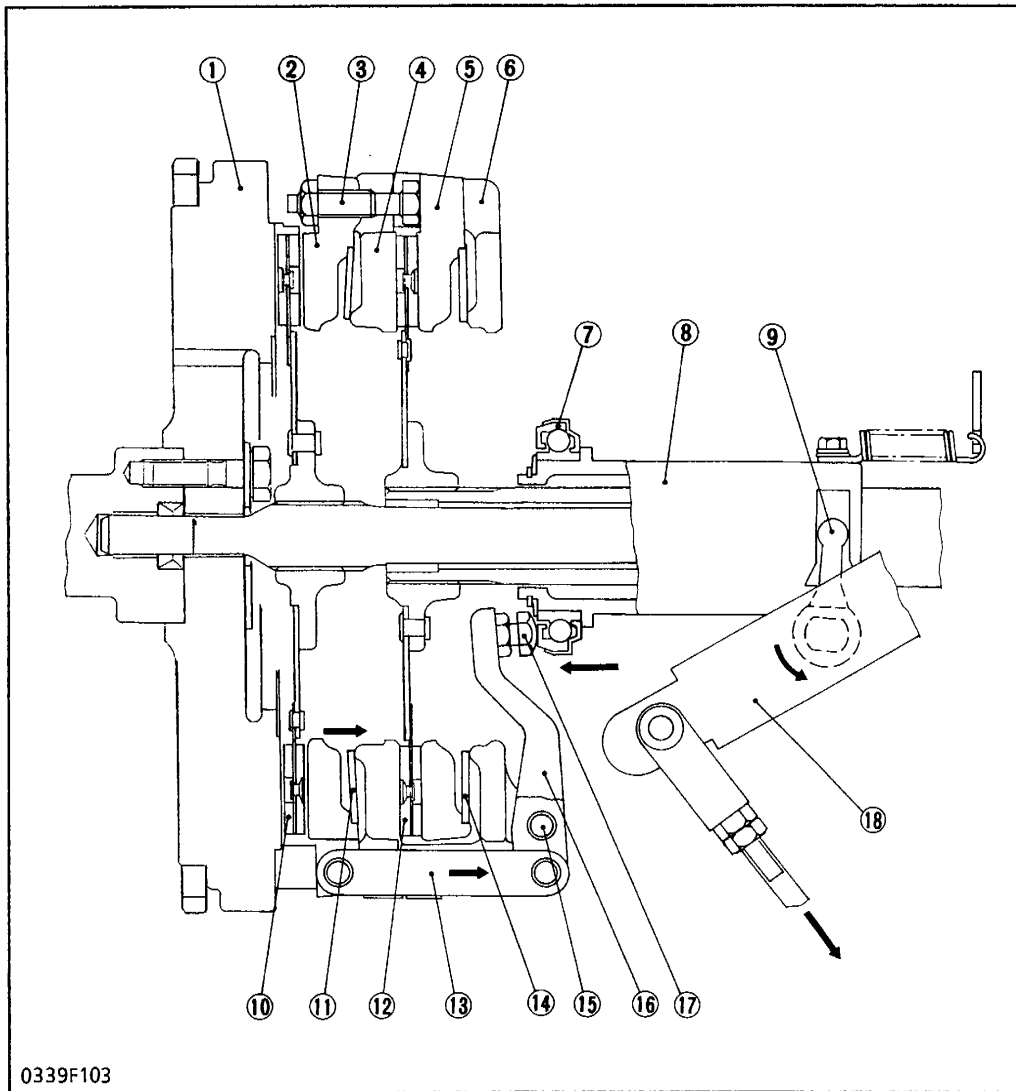

- (1) Flywheel
- (2) Pressure Plate (Travelling)
- (3) Adjusting Screw
- (4) Clutch Cover
- (5) Pressure Plate (PTO)
- (6) Clutch Cover
- (7) Release Bearing
- (8) Release Bearing Holder
- (9) Release Fork
- (10) Clutch Disc (Travelling)
- (11) Belleville Spring
- (12) Clutch Disc (PTO)
- (13) Release Rod
- (14) Belleville Spring
- (15) Clevis Pin
- (16) Release Lever
- (17) Adjusting Screw
- (18) Clutch Rod

0339F103

When the clutch pedal is depressed to the middle of the stroke, the clutch rod (18) rotates then the release fork (9) pushes the release bearing holder (8) and the release bearing (7) toward the flywheel (1). Simultaneously, the release bearing pushes the adjusting screw (17).

The release lever (16) pulls the pressure plate (2) by means of the release rod (13) as the lever turns at the clevis pin (15) as a fulcrum.

When the pressure plate (2) is pulled, the clutch disc (10) becomes free and the rotation of flywheel is not transmitted to the travelling system.

At this time, the pressure plate (5) is in contact with the head of the adjusting screw (3) which serves as a stopper.

■ Travelling Clutch and PTO Clutch "Disengaged"

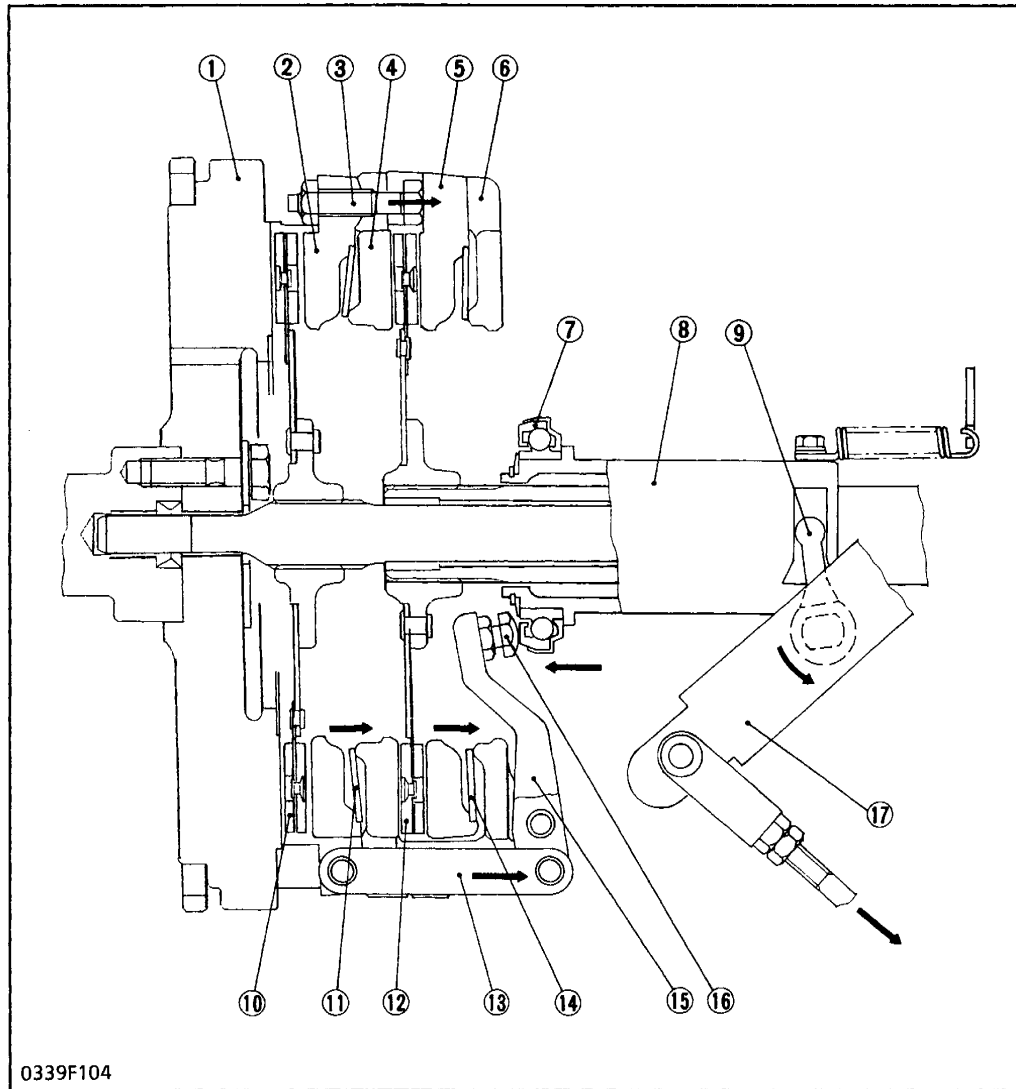

- (1) Flywheel
- (2) Pressure Plate (Travelling)
- (3) Adjusting Screw
- (4) Clutch Cover
- (5) Pressure Plate (PTO)
- (6) Clutch Cover
- (7) Release Bearing
- (8) Release Bearing Holder
- (9) Release Fork
- (10) Clutch Disc (Travelling)
- (11) Belleville Spring
- (12) Clutch Disc (PTO)
- (13) Release Rod
- (14) Belleville Spring
- (15) Release Lever
- (16) Adjusting Screw
- (17) Clutch Rod

0339F104

When the clutch pedal is depressed to the full stroke, the pressure plate (5) is pushed to the right by the adjusting screw (3).

This results in no friction among the clutch cover (4), clutch disc (12) and pressure plate (5).

The rotation of flywheel is not transmitted to the PTO system and travelling system.

3 TRANSMISSION

The transmission consists of a series of gears shown previously. It offers the most suitable speed for traveling and operation by combination of these gears.

It transmits power to the front or rear axles and the PTO shaft, which are classified respectively as the traveling system and PTO system.

■ B1550-B1750

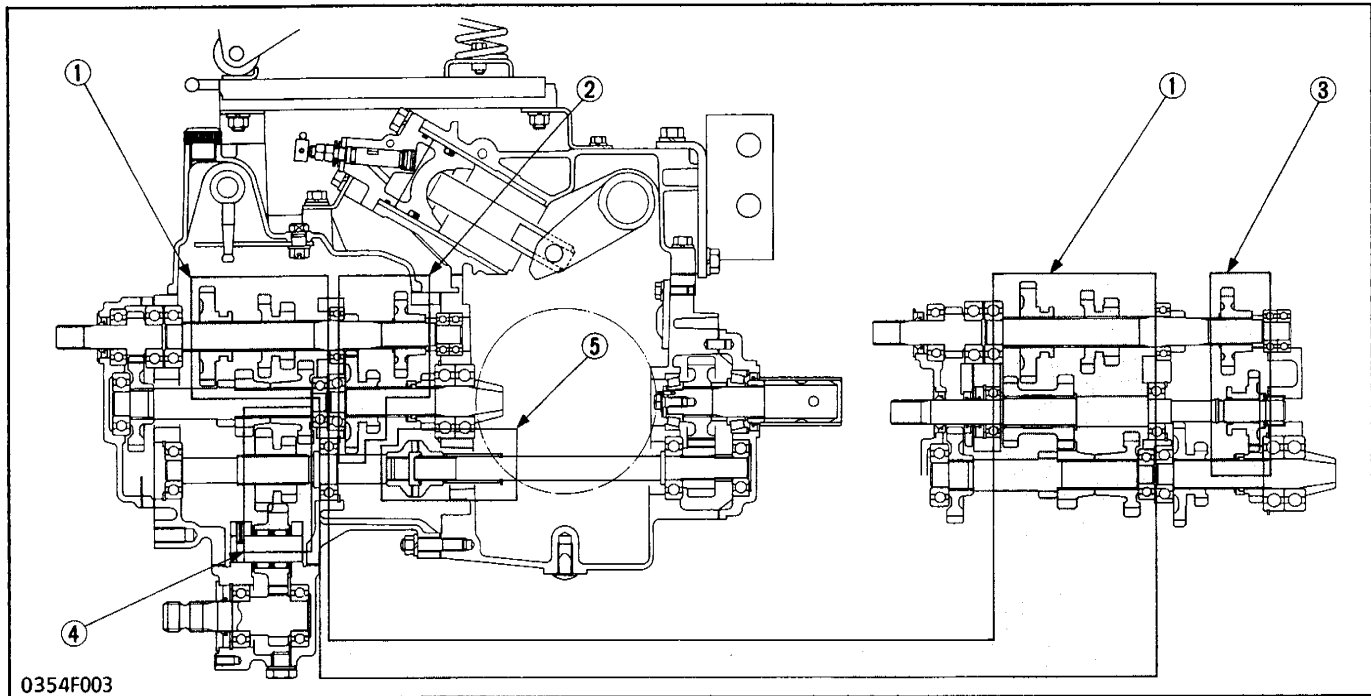

■ B1550HST-B1750HST

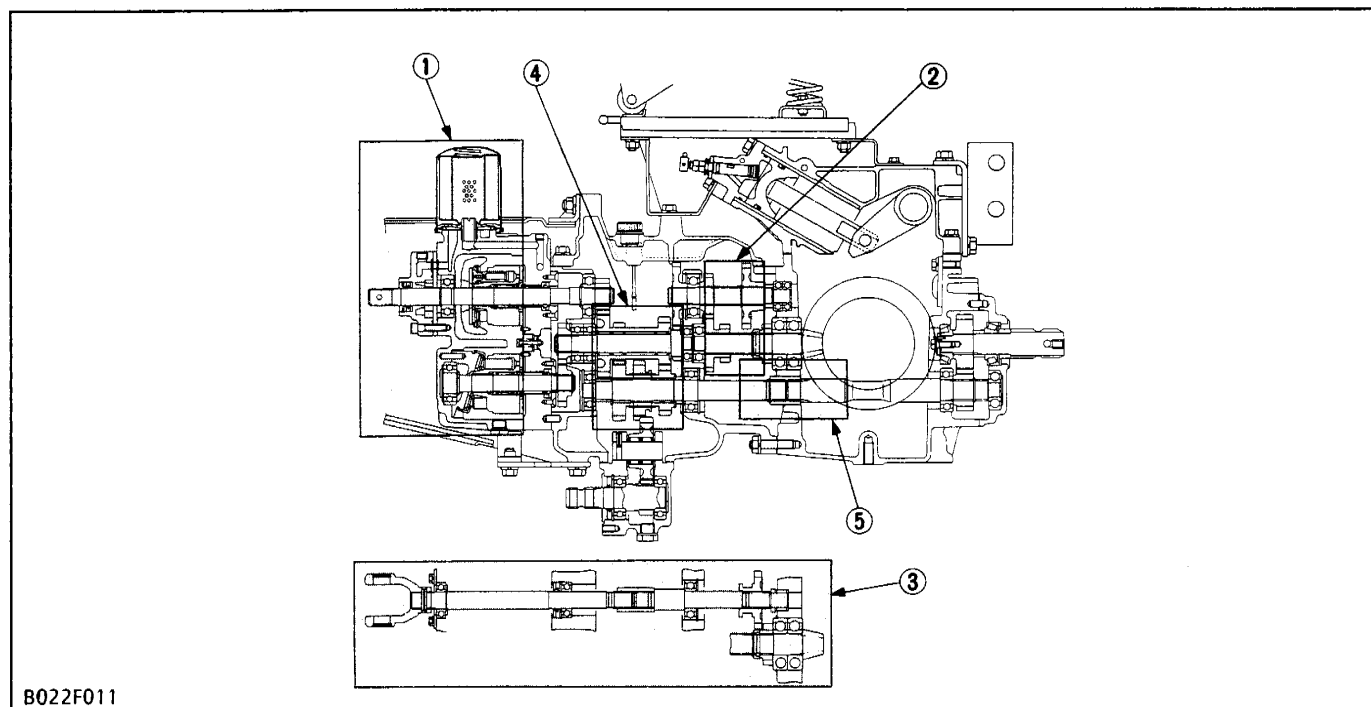

- (1) Main Gear Shift Section or Hydrostatic Transmission
- (2) Aux. Gear Shift Section
- (3) Front Wheel Drive Section
- (4) PTO Shift Section
- (5) One-way Clutch Section or Coupling

■ B2150

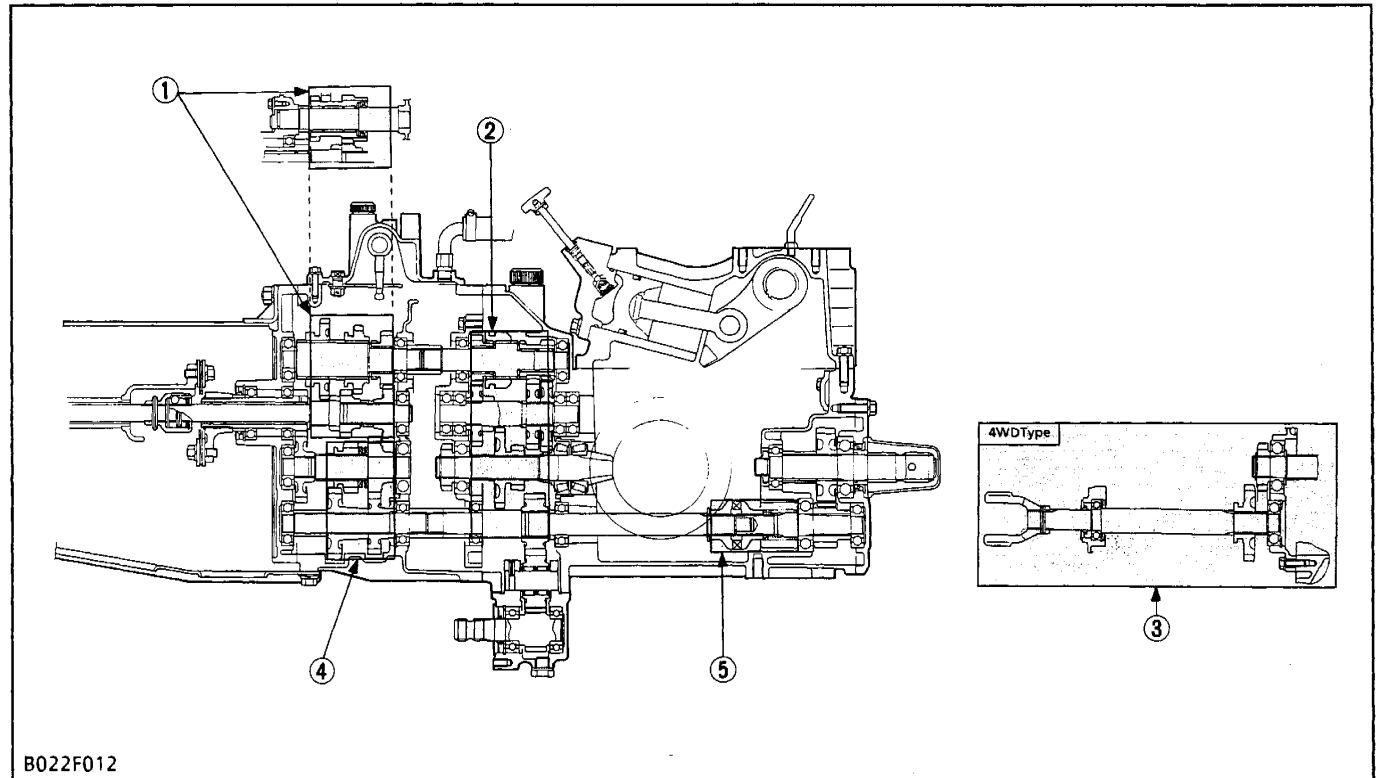

■ B2150HST

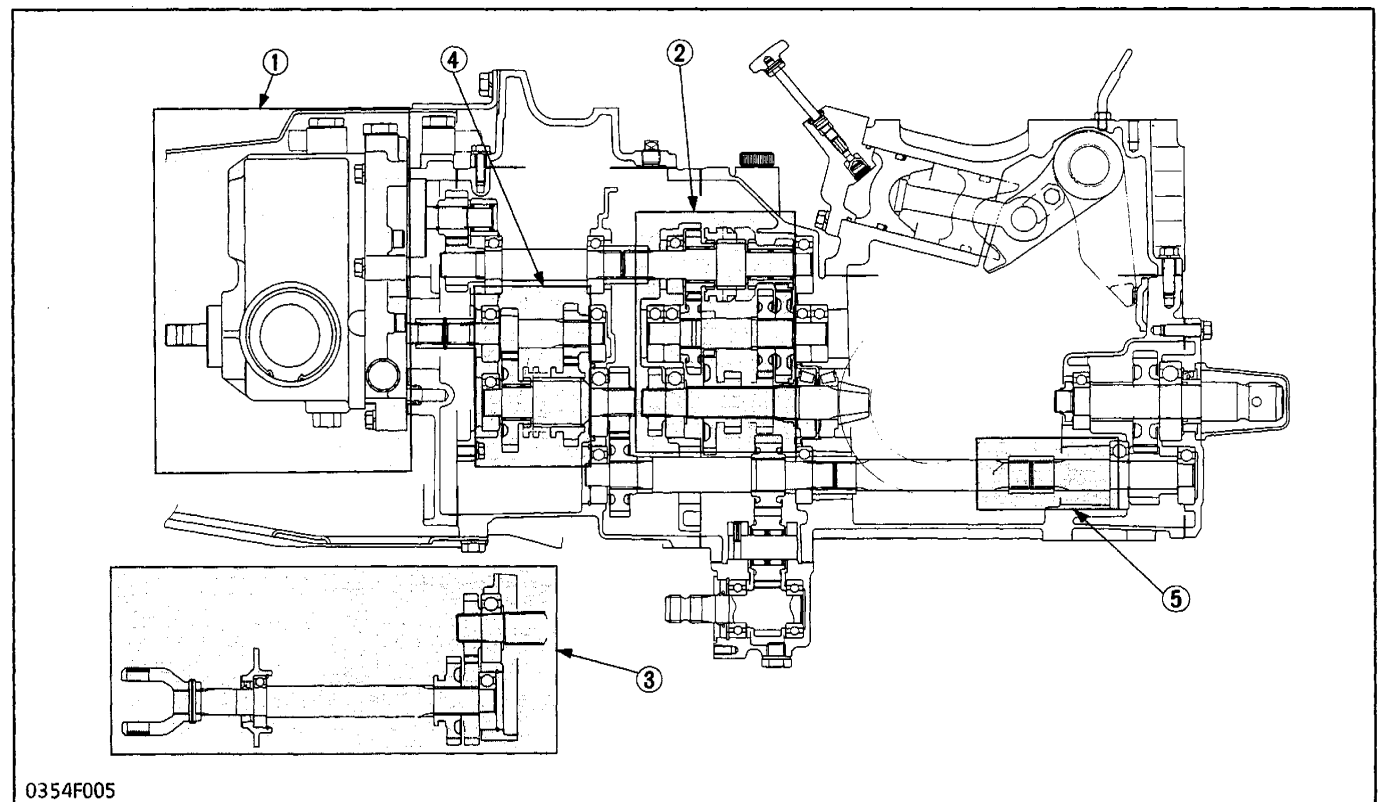

- (1) Main Gear Shift Section or Hydrostatic Transmission
- (2) Aux. Gear Shift Section
- (3) Front Wheel Drive Section
- (4) PTO Shift Section
- (5) One-way Clutch Section or Coupling

[1] TRAVELING SYSTEM

(1) Main Gear Shift Section

■ B1550-B1750

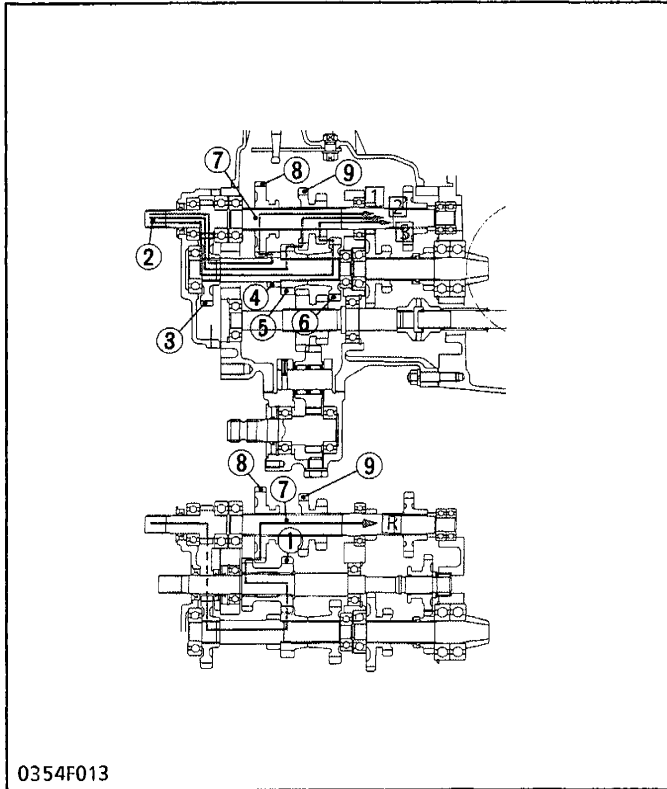

Besides neutral, four kinds of power flow (from 1st to 4th shaft) are available by operating the main gear shift lever to shift positions of the 30T shifter gear (8) and 13T -17T shifter gear (9) on the 4th shaft (7).

■ 1st Position

1st Shaft (2)→29T Gear (3)→2nd Shaft with 13T Gear (4)→30T Shifter Gear (8)→4th Shaft (7)

■ 2nd Position

1st Shaft (2)→29T Gear (3)→2nd Shaft (4)→13T Gear (5)→(13T)-17T Shifter Gear (9)→4th Shaft (7)

■ 3rd Position

1st Shaft (2)→29T Gear (3)→2nd Shaft (4)→17T Gear (6)→13T-(17T) Shifter Gear (9)→4th Shaft (7)

■ Reverse Position

1st Shaft (2)→29T Gear (3)→2nd Shaft (4)→13T Gear (5)→16T-20T Gear (1)→30T Shifter Gear (8)→4th Shaft (7)

- | | |
|-----------------------------|--------------------------|
| (1) 16T-20T | (6) 17T Gear |
| (2) 1st Shaft with 14T Gear | (7) 4th Shaft |
| (3) 29T Gear | (8) 30T Shifter Gear |
| (4) 2nd Shaft with 13T Gear | (9) 13T-17T Shifter Gear |
| (5) 13T Gear | |

■ B2150

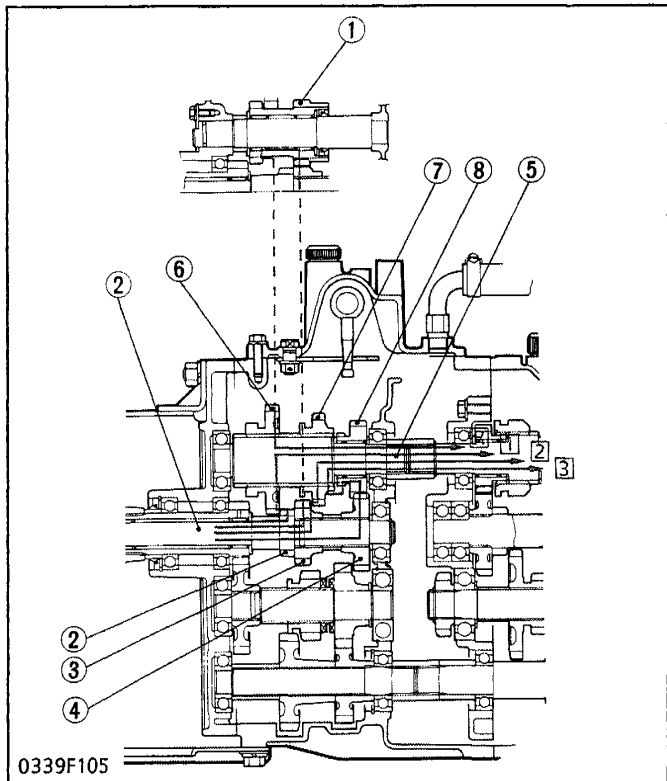

Besides neutral, four kinds of power flow (from 1st to 2nd shaft) are selected by operating the main gear shift lever to shift positions of the 32T shifter gear (6) and 24T shifter gear (7).

■ 1st Position

1st Shaft with 12T Gear (2)→32T Shifter Gear (6)→2nd Shaft (5)

■ 2nd Position

1st Shaft (2)→16T Gear (3)→24T Shifter Gear (7)→2nd Shaft (5)

■ 3rd Position

1st Shaft (2)→20T Gear (4)→20T Gear (8)→24T Shifter Gear (7)→2nd Shaft (5)

■ Reverse Position

1st Shaft (2)→16T Gear (3)→16T-16T Gear (1)→32T Shifter Gear (6)→2nd Shaft (5)

- | | |
|-----------------------------|----------------------|
| (1) 16T-16T Gear | (5) 2nd Shaft |
| (2) 1st Shaft with 12T Gear | (6) 32T Shifter Gear |
| (3) 16T Gear | (7) 24T Shifter Gear |
| (4) 20T Gear | (8) 20T Gear |

■ NOTE

- Refer to the auxiliary gear shift section in M.3-32.

(2) Hydrostatic Transmission

■ B1550HST-B1750HST

■ NOTE

- The hydrostatic transmission for the tractors from the serial number written below is explained on page BM.3-1 to BM.3-11 and BS.3-1 to BS.3-17.

Models	Serial number
B1550 HST (2WD)	above 20001
B1550 HST (4WD)	above 60001
B1750 HST (2WD)	above 20001
B1750 HST (4WD)	above 60001

1. Structure

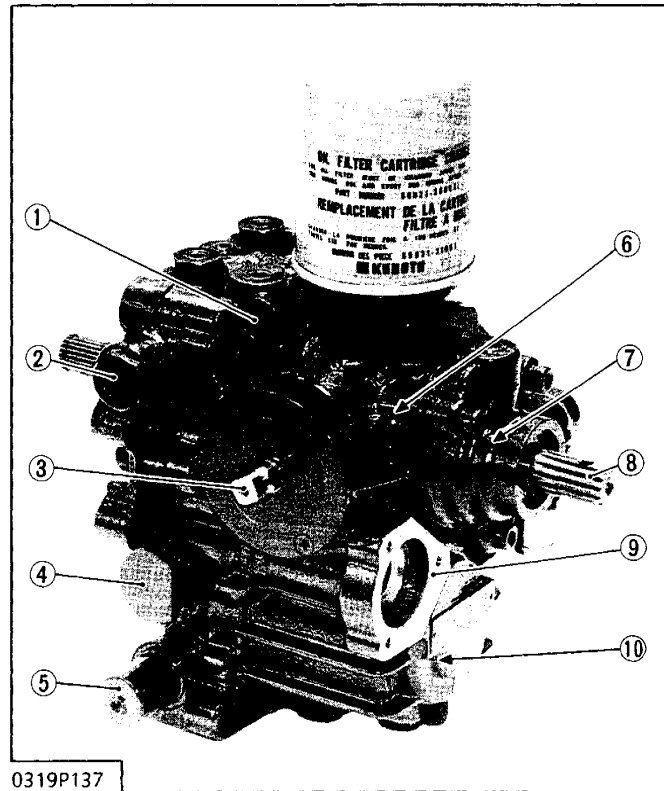

0319P137

- | | |
|-------------------------|---------------------------------------|
| (1) Charge Relief Valve | (5) High Pressure Relief Valve |
| (2) Neutral Valve | (6) Variable Displacement Piston Pump |
| (3) Trunnion Shaft | |
| (4) Port Block | |

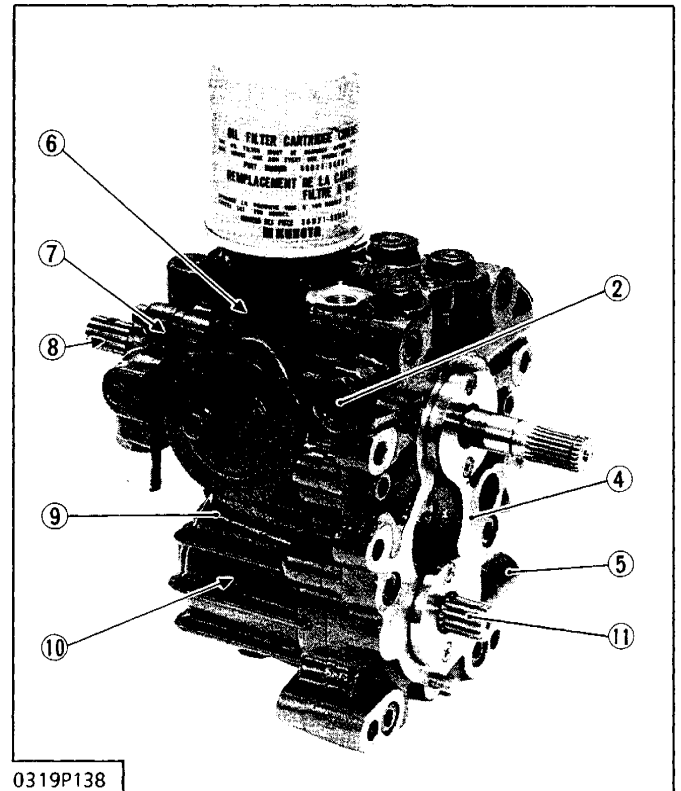

0319P138

- | | |
|-----------------|--------------------------------------|
| (7) Charge Pump | (10) Fixed Displacement Piston Motor |
| (8) Input Shaft | (11) Output Shaft |
| (9) Case | |

Hydrostatic transmission is composed of variable displacement piston pump, fixed displacement piston motor, charge pump and valve system.

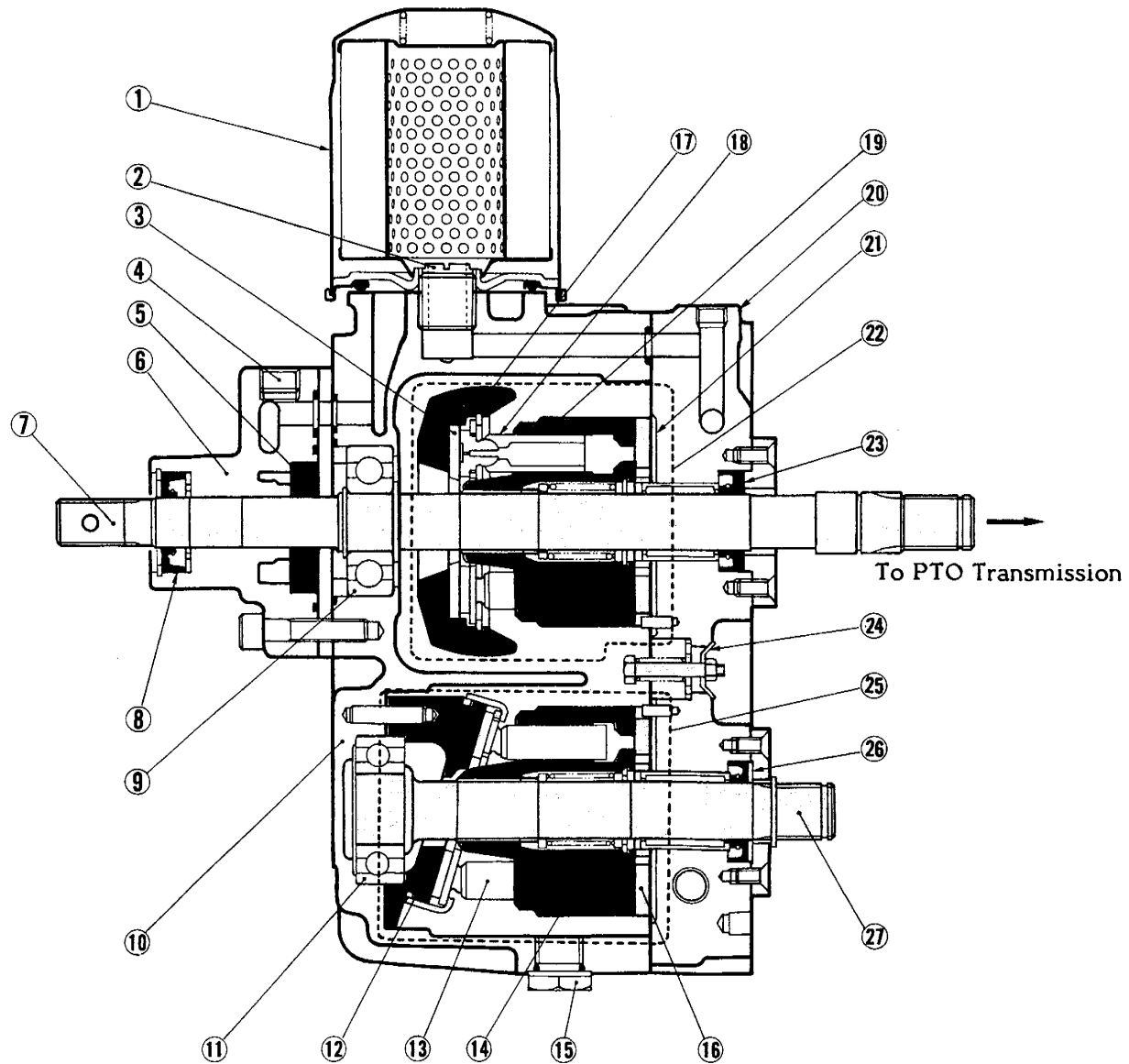

0319F142

- | | | | |
|-----------------------------|-----------------------|--|--------------------------------------|
| (1) Oil Filter Cartridge | (9) Ball Bearing | (17) Variable Swashplate | (23) Oil Seal |
| (2) Joint | (10) Case | (18) Piston | (24) Case Relief Valve |
| (3) Thrust Plate | (11) Ball Bearing | (19) Cylinder Block | (25) Fixed Displacement Piston Motor |
| (4) P3 Port | (12) Fixed Swashplate | (20) Port Block | (26) Oil Seal |
| (5) Trochoid Rotor Assembly | (13) Piston | (21) Valve Plate | (27) Output Shaft |
| (6) Charge Pump Case | (14) Cylinder Block | (22) Variable Displacement Piston Pump | |
| (7) Input Shaft | (15) Drain Plug | | |
| (8) Oil Seal | (16) Valve Plate | | |

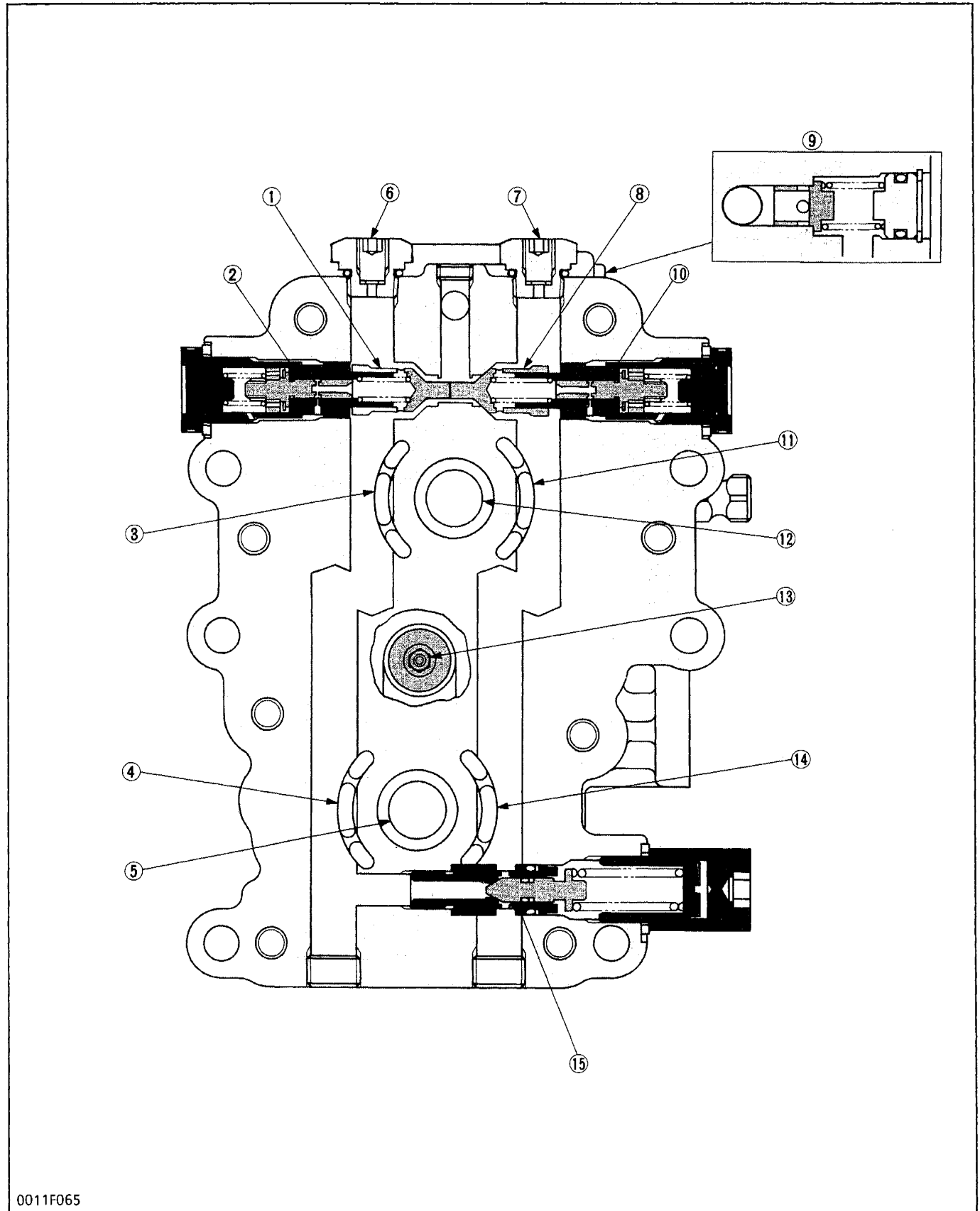

0011F065

- | | | | |
|-----------------------------|------------------|------------------------------|---------------------------------|
| (1) Check Valve | (5) Output Shaft | (9) Charge Relief Valve | (13) Case Relief Valve |
| (2) Neutral Valve (Forward) | (6) P1 Port | (10) Neutral Valve (Reverse) | (14) Motor Kidney Port D |
| (3) Pump Kidney Port A | (7) P2 Port | (11) Pump Kidney Port B | (15) High Pressure Relief Valve |
| (4) Motor Kidney Port C | (8) Check Valve | (12) Input Shaft | |

2. Pump and Motor

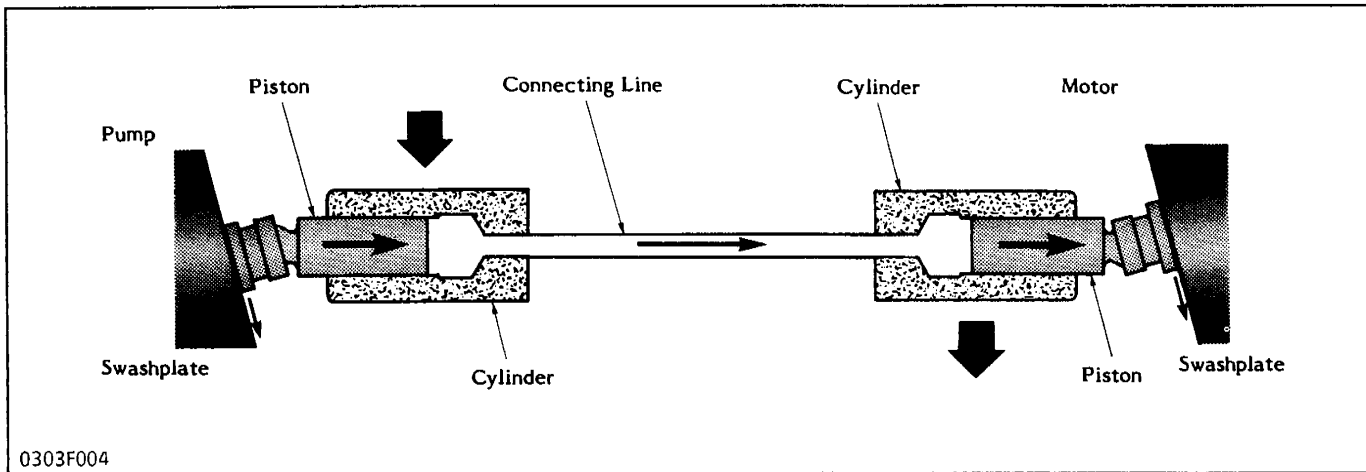

Pump and motor cylinder, each containing pistons, are connected by lines. Cylinders and lines are filled with oil. Pistons ride against swashplates located in pump and motor.

In the pump, as the cylinder rotates, pistons move across the sloping face of swashplate and slide in or out of their cylinder bores.

The oil, forced out by the pump pistons, causes the motor pistons to slide out of their cylinder bores. In the motor, sliding out of the cylinder and moving across the sloping face of swashplate, the pistons rotate the cylinder.

3. Variable Swashplate

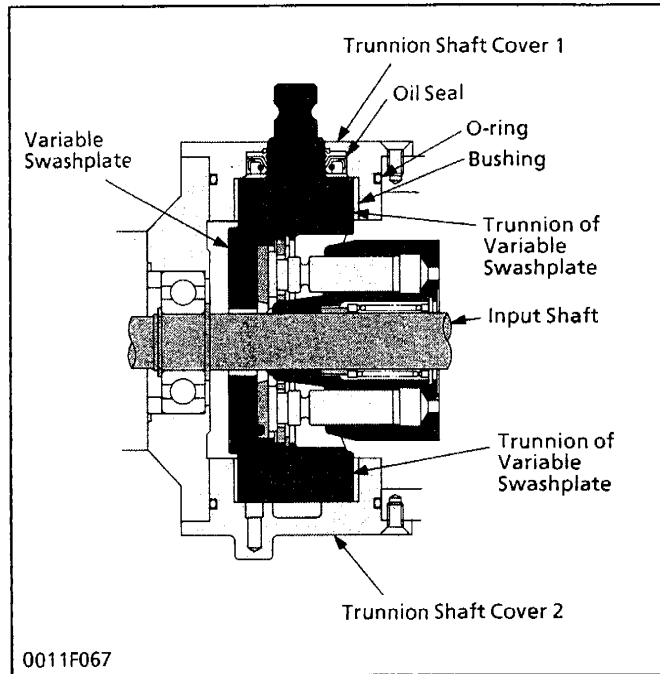

This pump is variable displacement one. The angle of its swashplate can be varied so that the volume and pressure of oil pumped by the pistons can be changed or the direction of oil flow can be reversed. The swashplate is moved around the trunnion shaft with the neutral holder, by stepping on the speed control pedal linked to the neutral holder.

4. Oil Flow and Valves

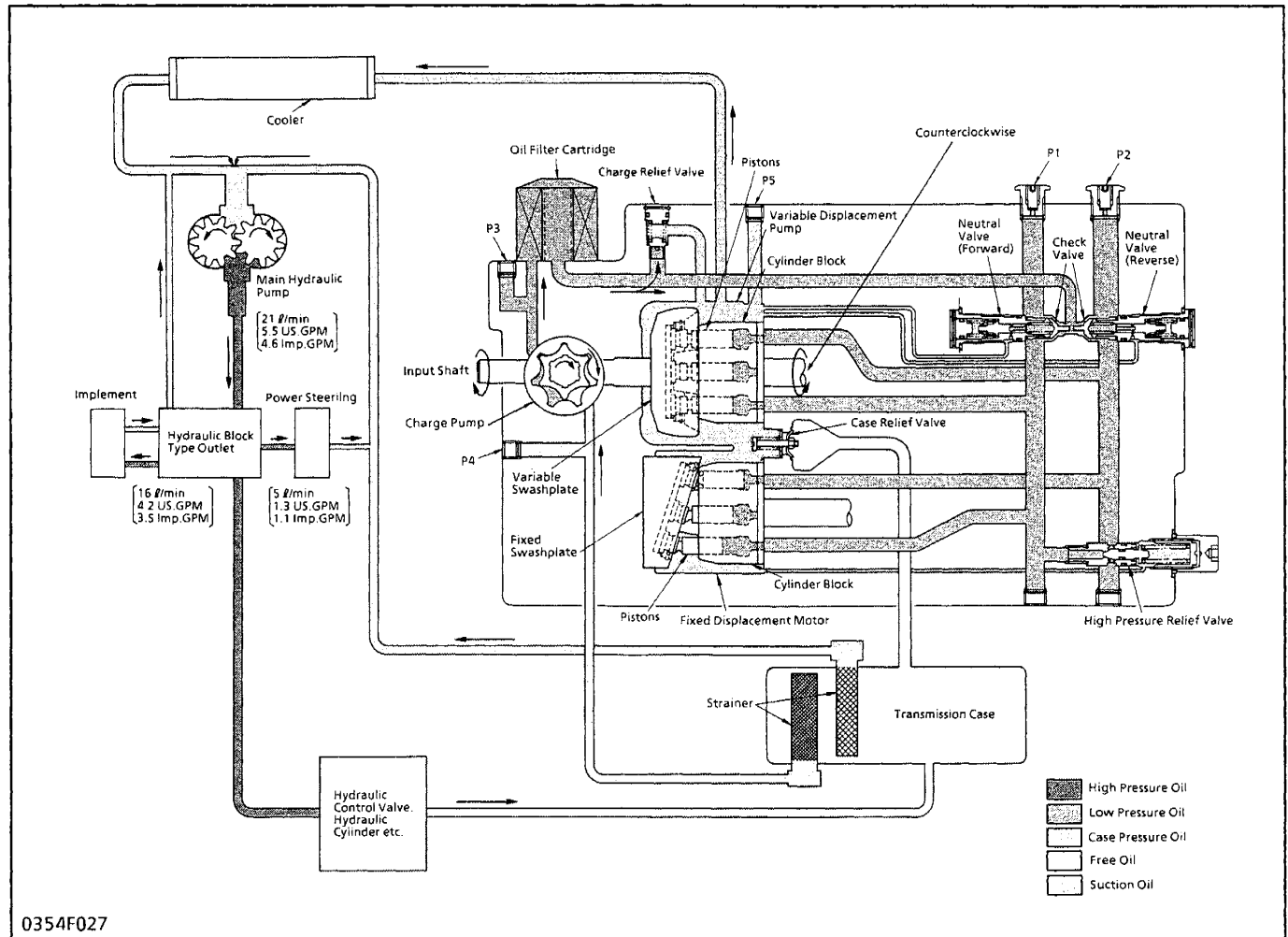

- P1: Port for checking high pressure (forward)
- P2: Port for checking high pressure (reverse)
- P3: Port for checking case pressure

- P4: Port for checking vacuum
- P5: Port for checking case pressure

The pump and motor are joined in a closed hydraulic loop and most of oil circulates within the main oil circuit. A little oil lubricates and oozes out from the clearance between the moving parts of the case. Then oil in the main oil circuit of the hydrostatic transmission needs to be supplied a want. So all of oil fed from the main hydraulic pump flows to the hydrostatic transmission for charging.

Only return oil from the hydraulic cylinder drops to the transmission case.

The charge oil aids smooth operation of piston pump and motor. The rest of the oil passes through the charge relief valve into the case. Then the oil passes to the main hydraulic pump through a cooler.

■ Charge Relief Valve

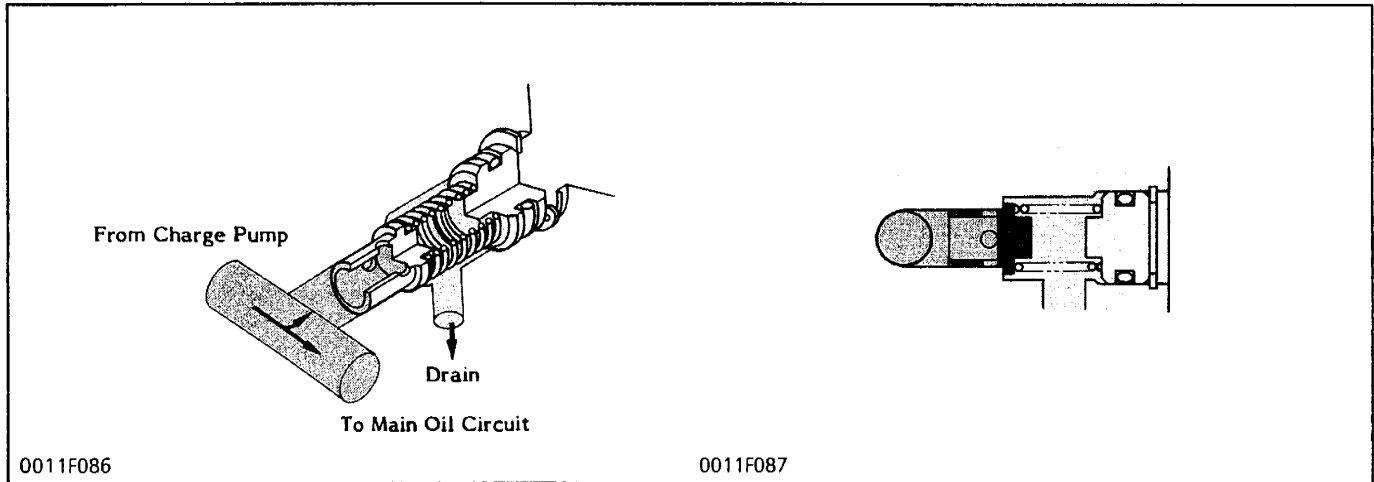

While pumped and filtered oil flows into the main oil circuit through the check valves, excessive oil passes to the case through the charge relief valve.

Oil temperature	Valve operating pressure
25°C (77°F)	440 to 580 kPa (4.5 to 5.9 kgf /cm ² , 64 to 84 psi) more than case pressure
50°C (122°F)	420 to 560 kPa (4.3 to 5.7 kgf /cm ² , 61 to 81 psi) more than case pressure

■ Neutral Valve

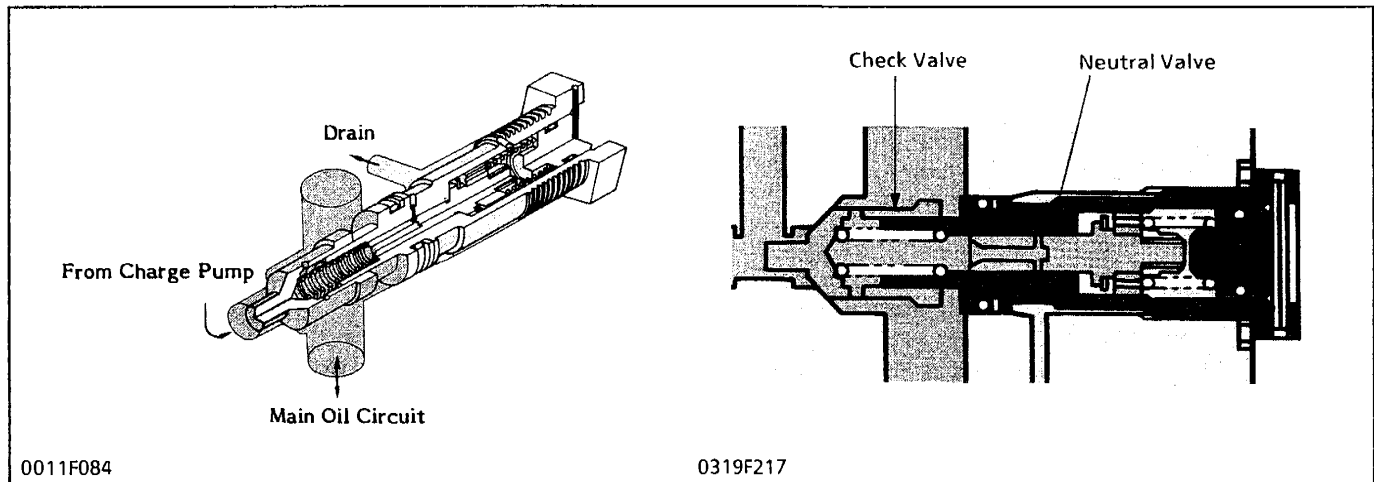

The neutral valves in the main oil circuit lines are open and pass the oil to the case when in neutral, and the oil pressure in their lines becomes low. And when the oil pressure in the high pressure line increases to a specified pressure, the neutral valve closes.

Valve operating pressure
Approx. 3.24 Mpa (33 kgf /cm ² , 469 psi)

■ High Pressure Relief Valve

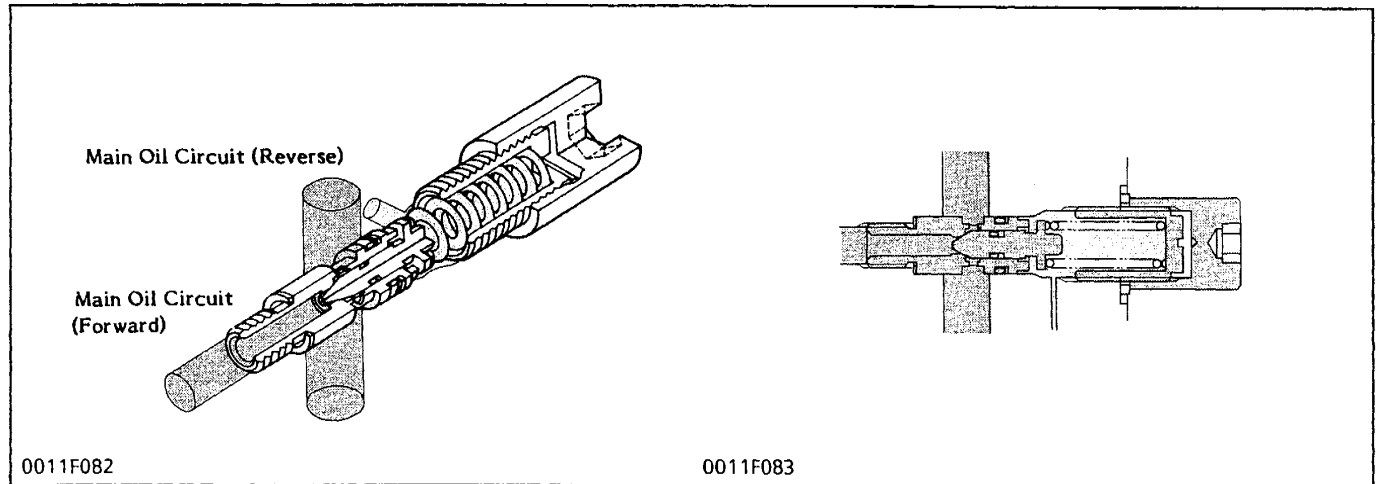

The high pressure relief valve between the two lines in the main oil circuit monitors the oil pressure in each line. When excessively high pressure is built up in one line, it opens and close the oil into another line.

Oil temperature	Valve operating pressure
25° to 50°C (77° to 122°F)	22.5 to 24.5 Mpa (230 to 250 kgf /cm ² , 3270 to 3560 psi)

■ Case Relief Valve

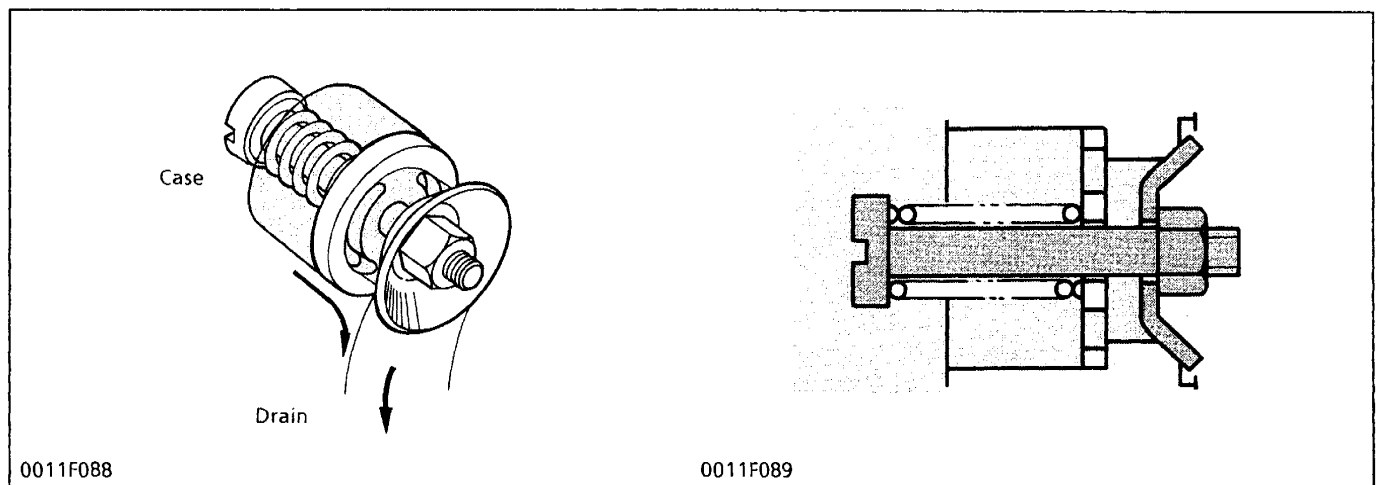

The case relief valve monitors the oil pressure in the hydrostatic transmission case. When the oil pressure rises, it opens and flows the oil directly to the transmission case, so that the oil may not leak against the sealings.

Oil temperature	Valve operating pressure
25° to 50°C (77° to 122°F)	170 to 230 kpa (1.7 to 2.3 kgf /cm ² , 24 to 32 psi)

5. Operation

■ Neutral

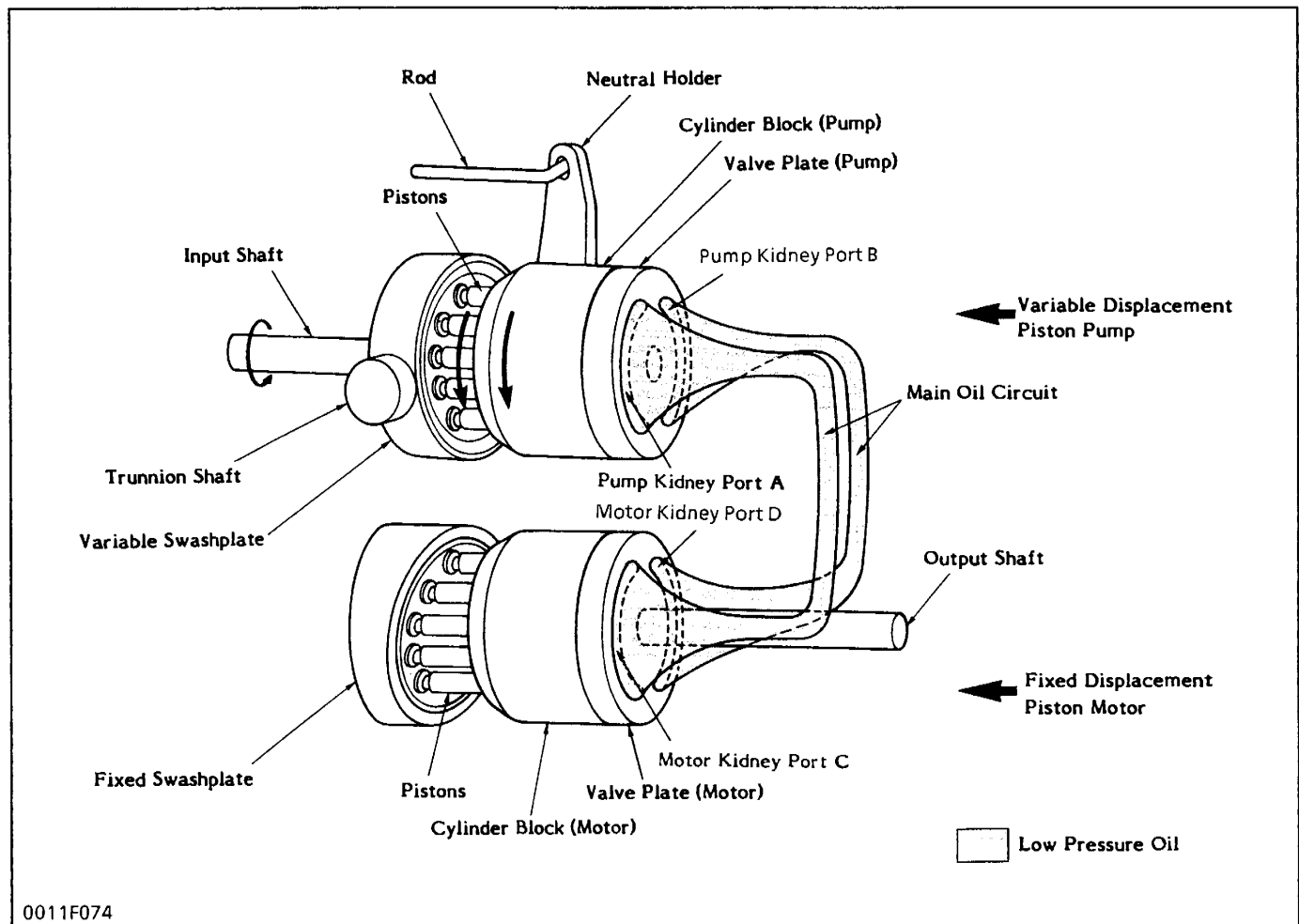

When the speed control pedal is in neutral, the variable swashplate is at right angles to the pump pistons and they only rotate with cylinder block without reciprocating. Since the oil is not being pumped to the motor, the cylinder block in the motor is stationary and the output shaft does not move.

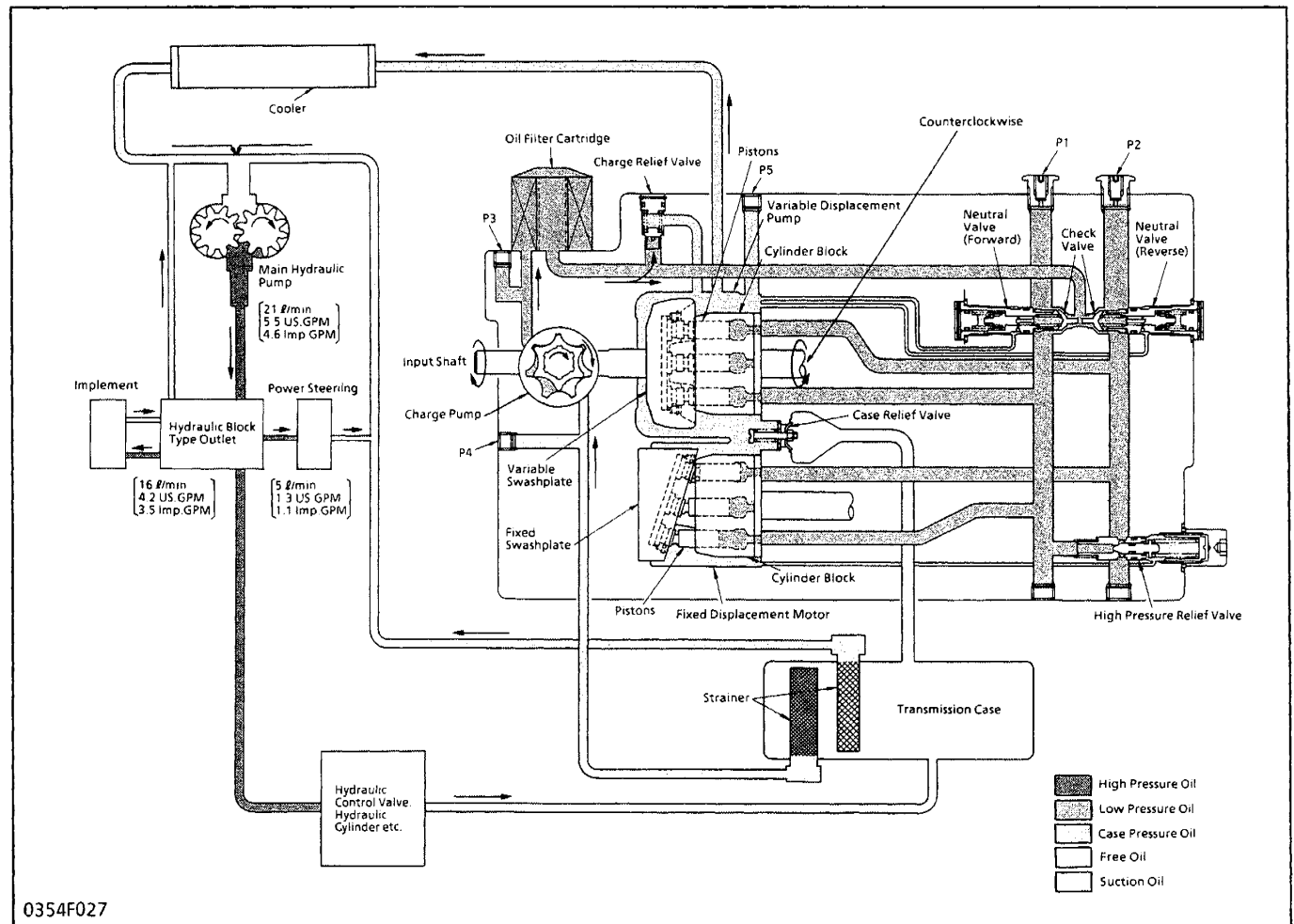

■ Forward

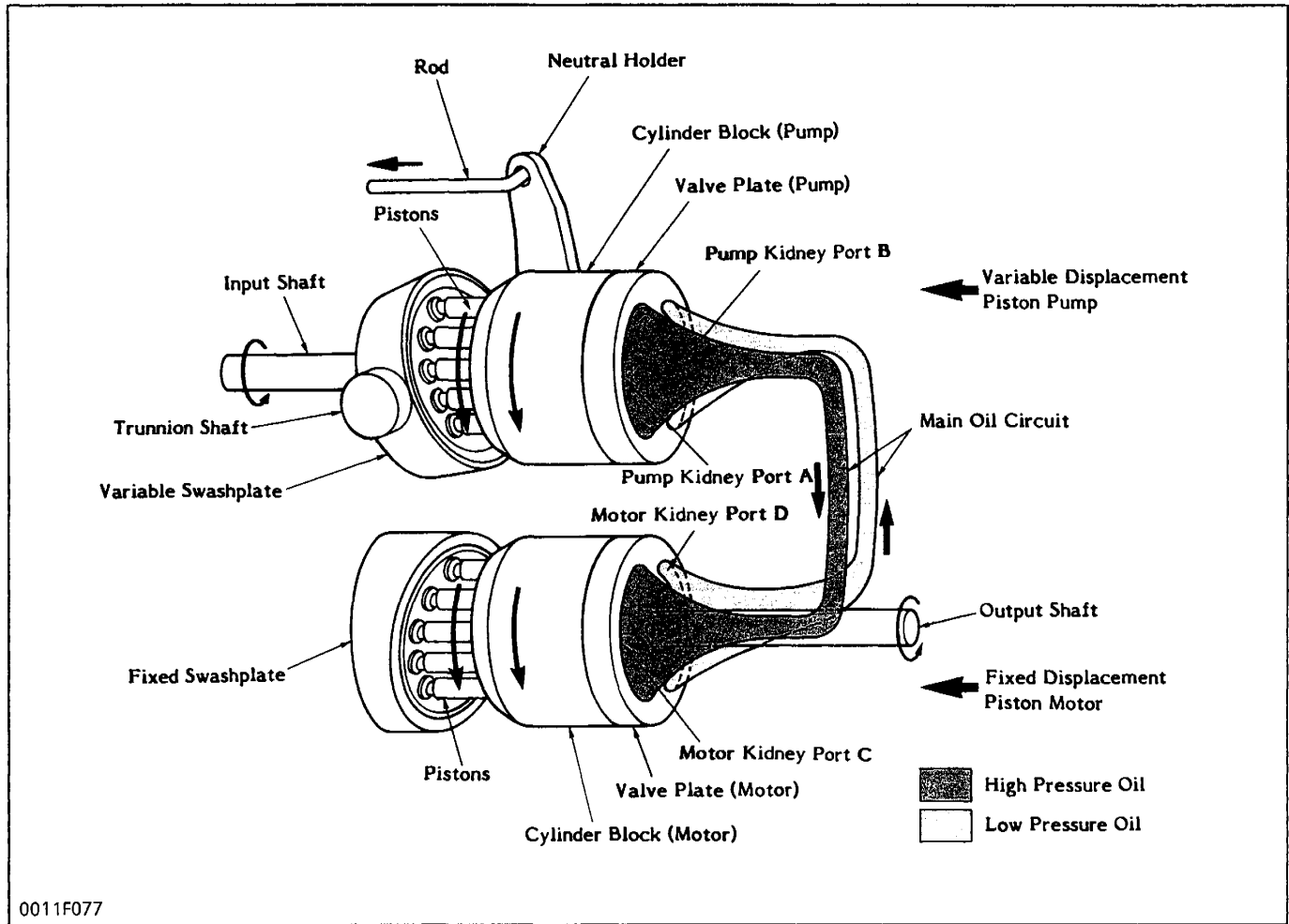

When the speed control pedal is stepped on and in forward, the variable swashplate is tilted as shown in figure above.

As the pump cylinder block rotates with the input shaft, oil is forced out of pump kidney port A at high pressure. As pressure oil enters motor kidney port C, the pistons, which align with port C, are pushed against the swashplate and slide down the inclined surface.

Then the output shaft rotates with the motor cylinder block. This drives the machine forward and the angle of pump swashplate determines the output shaft speed.

As the motor cylinder block continues to rotate, oil is forced out of motor kidney port D at low pressure and returns to the pump.

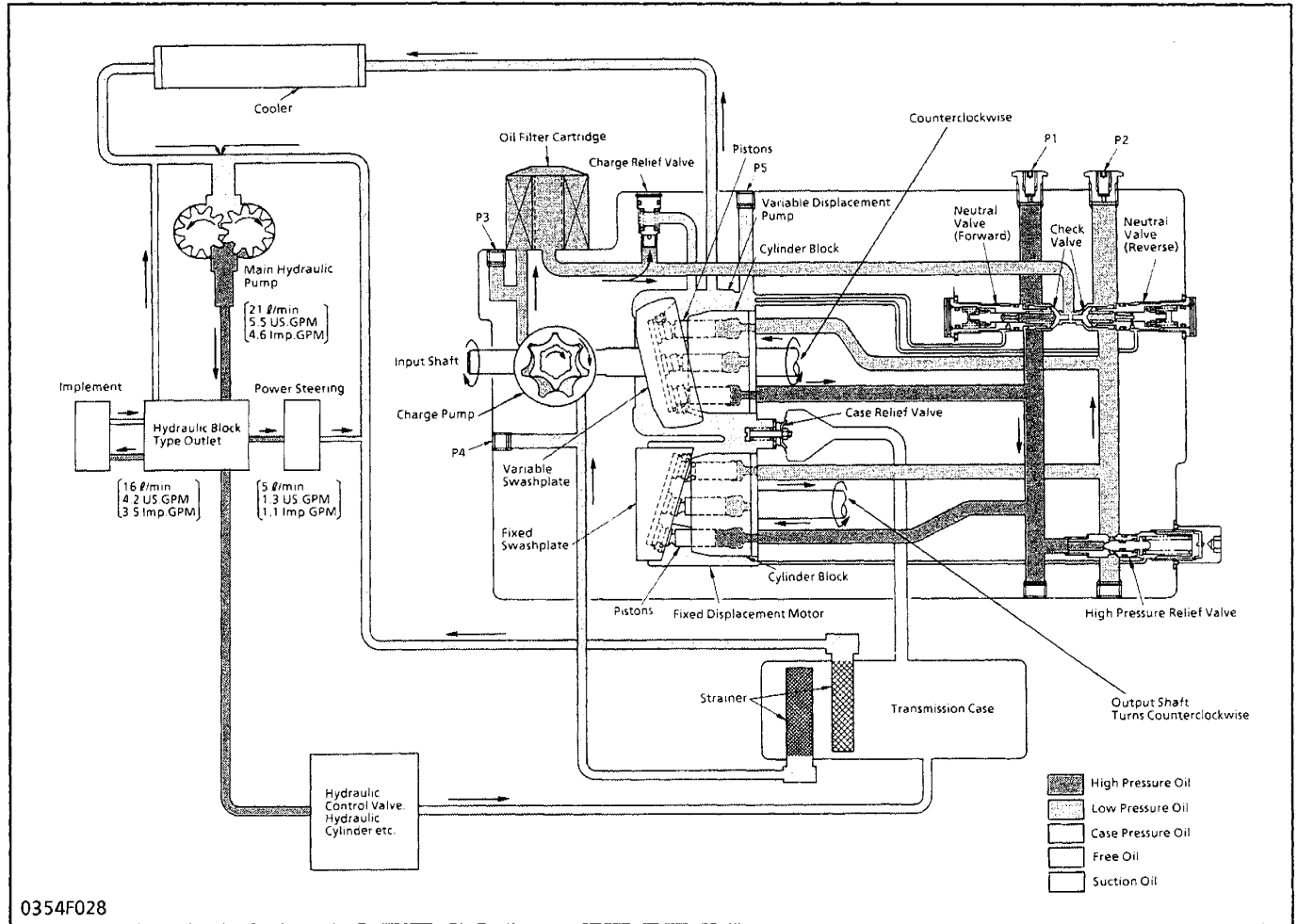

■ Reverse

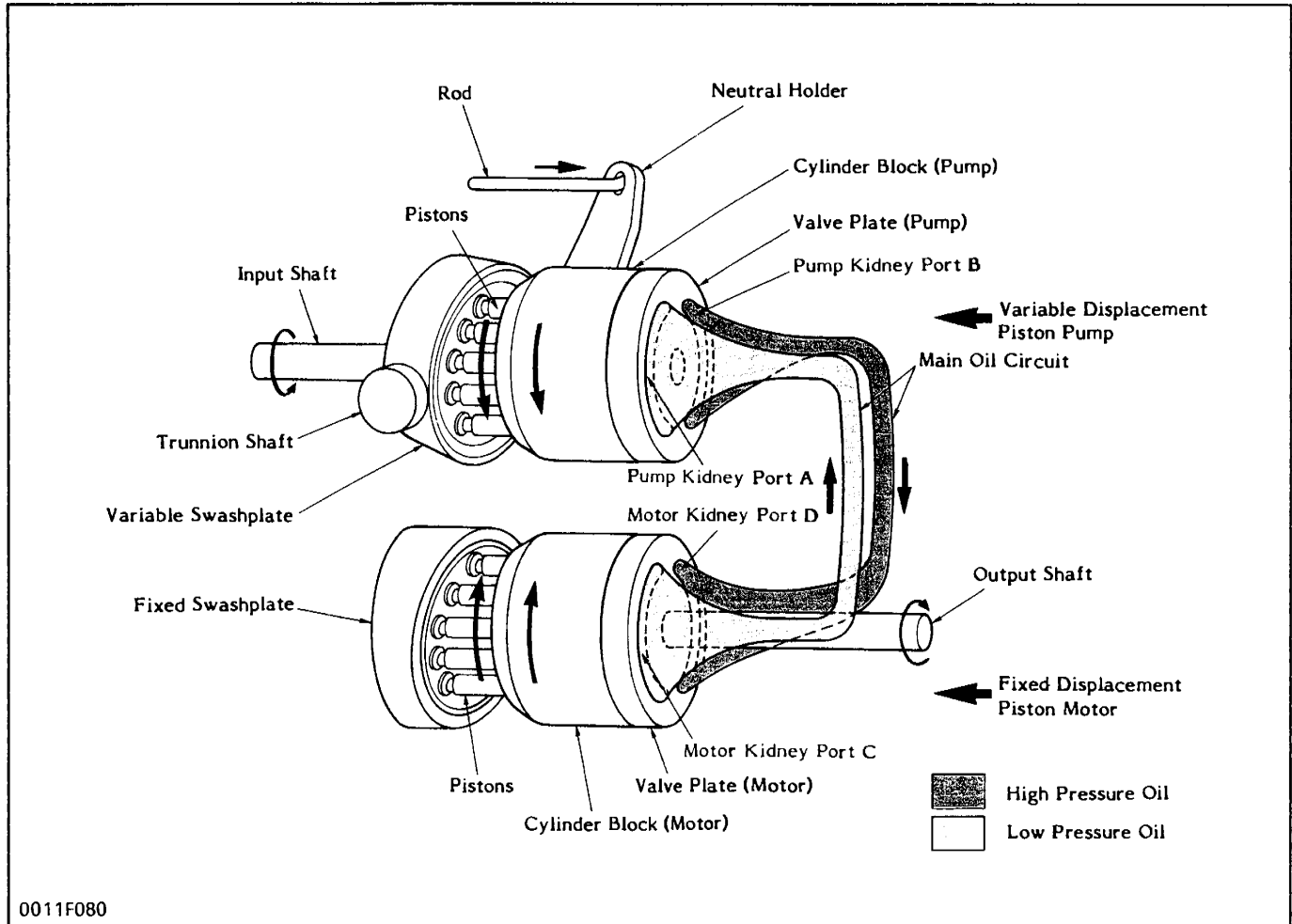

When the speed control pedal is stepped on and in reverse, the variable swashplate is tilted as shown in figure above.

As the pump cylinder block rotates with the input shaft, oil is forced out of pump kidney port B at high pressure. As pressure oil enters motor kidney port D, the pistons, which align with port D, are pushed against the swashplate and slide down the inclined surface.

Then the output shaft rotates with the motor cylinder block. This drives the machine rearward and the angle of pump swashplate determines the output shaft speed.

As the motor cylinder block continues to rotate, oil is forced out of motor kidney port C at low pressure and returns to the pump.

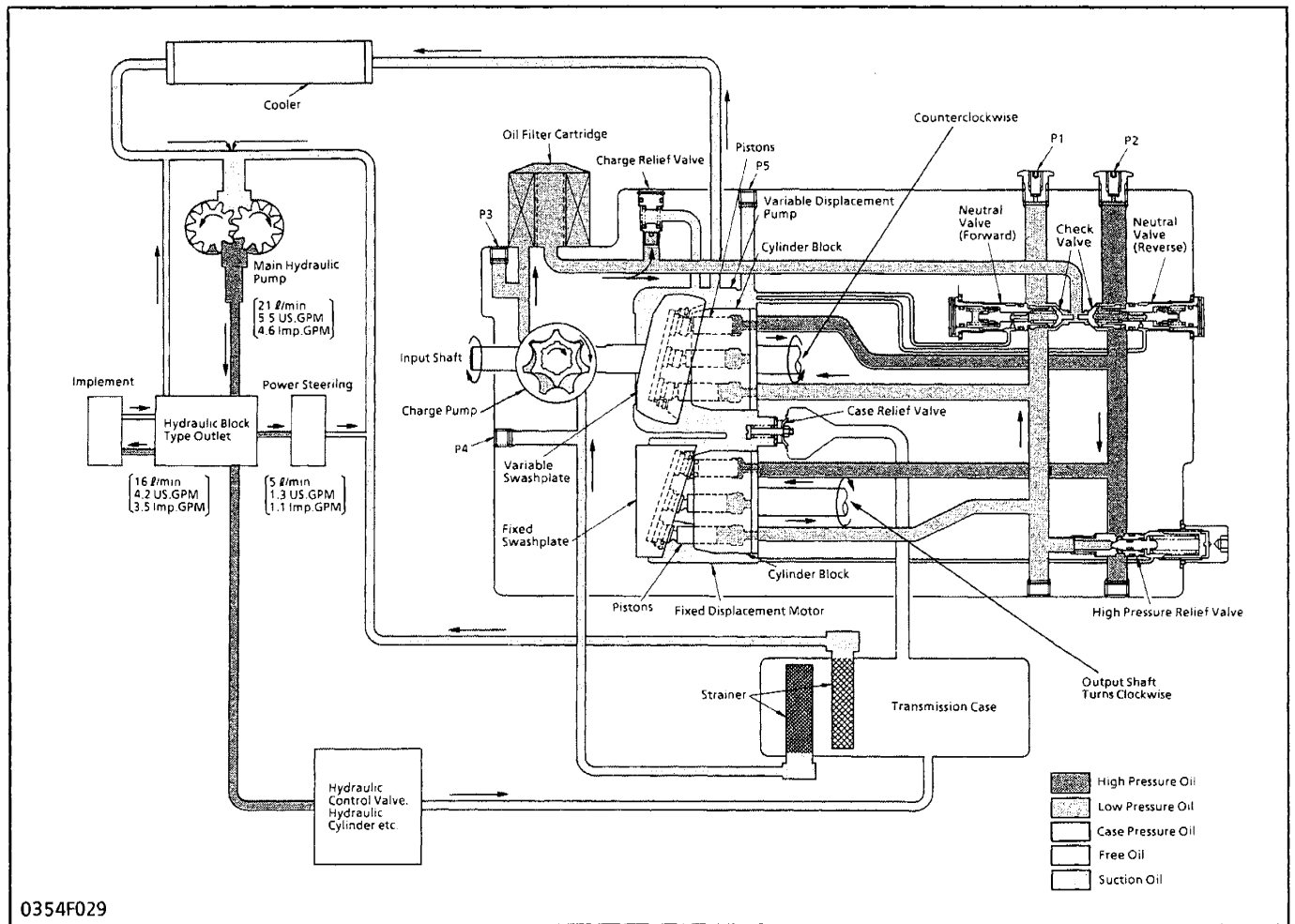

6. Control Linkage

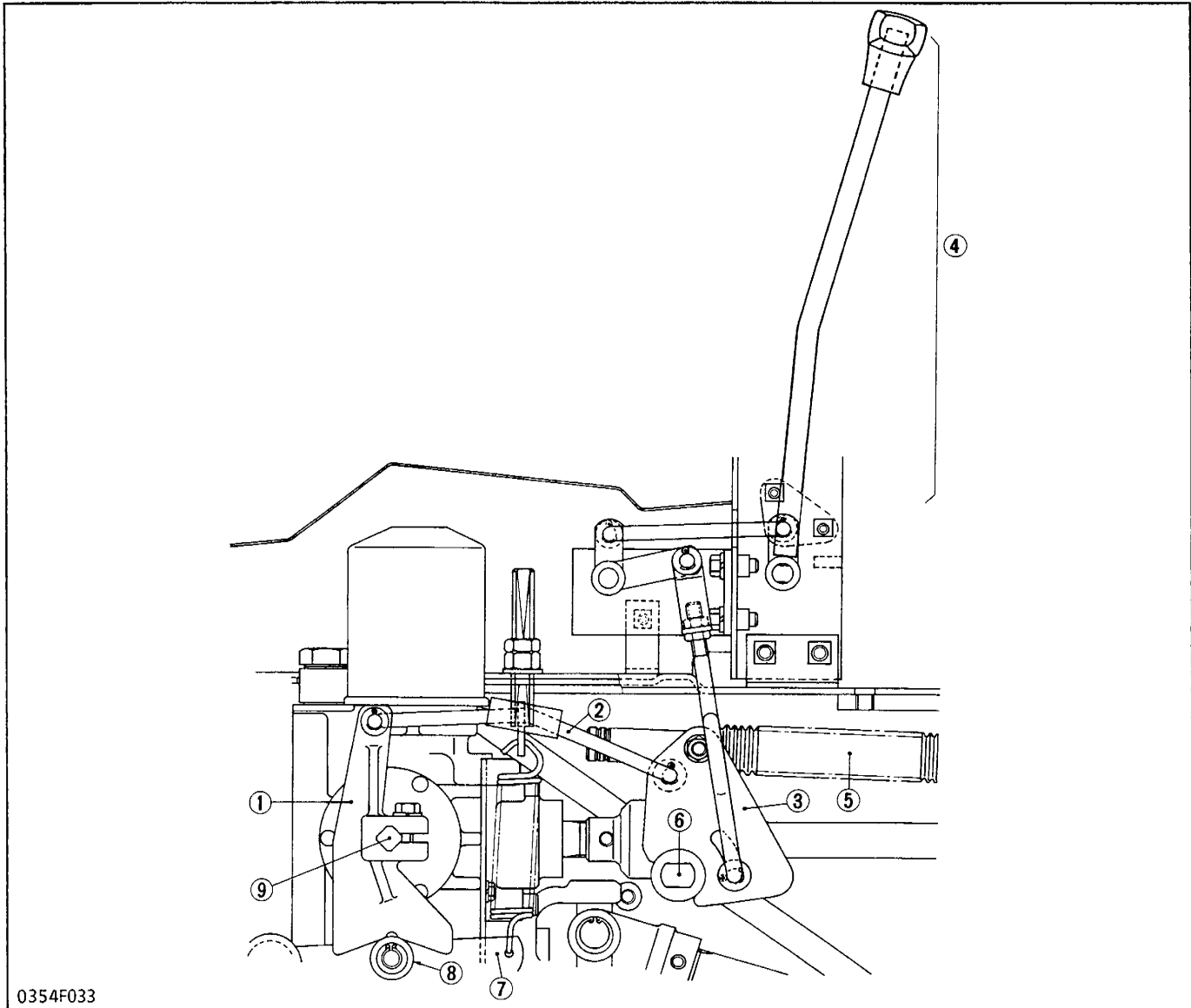

0354F033

- | | | | |
|-----------------------|----------------------|-------------------------------|--------------------|
| (1) Neutral Holder | (4) Speed Set Device | (6) Speed Control Pedal Shaft | (8) Roller |
| (2) Speed Control Rod | (5) Damper | (7) Neutral Holder Arm | (9) Trunnion Shaft |
| (3) Rod Guide | | | |

The speed control pedal and the trunnion shaft (9) of variable swashplate are linked with the rod guide (3), the speed control rod (2) and the neutral holder (1). As the front footrest of the pedal is depressed, the swashplate rotates and forward traveling speed increases. Depressing the rear footrest increases reverse speed.

The roller (8) on the neutral holder arm (7) hanged with spring seats the detent of the neutral holder (1) so that the neutral holder returns to neutral.

Then, the swashplate is returned to neutral with the neutral holder, when the pedal is released. The damper (5) connected to the rod guide (3) restricts the movement of the linkage to prevent abrupt operation or reversing.

The speed set device (4) linked to the rod guide (3) enables the linkage not to return to neutral and to keep a certain forward speed while the speed control pedal (6) is released.

(2) Hydrostatic Transmission (Continued)

■ B2150HST

1. Structure

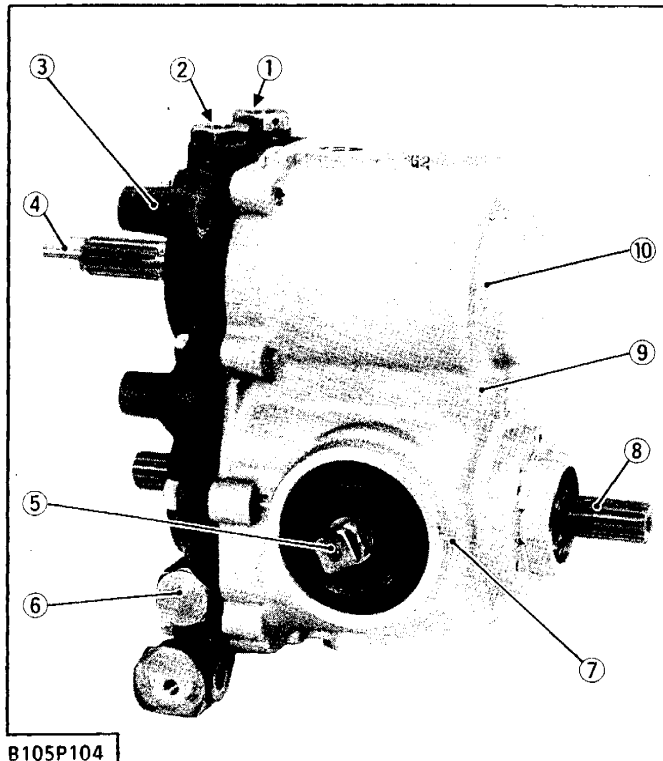

B105P104

- (1) Neutral Valve (Forward)
- (2) Neutral Valve (Reverse)
- (3) Port Block
- (4) Output Shaft
- (5) Trunnion Shaft
- (6) Check and High Pressure Relief Valve

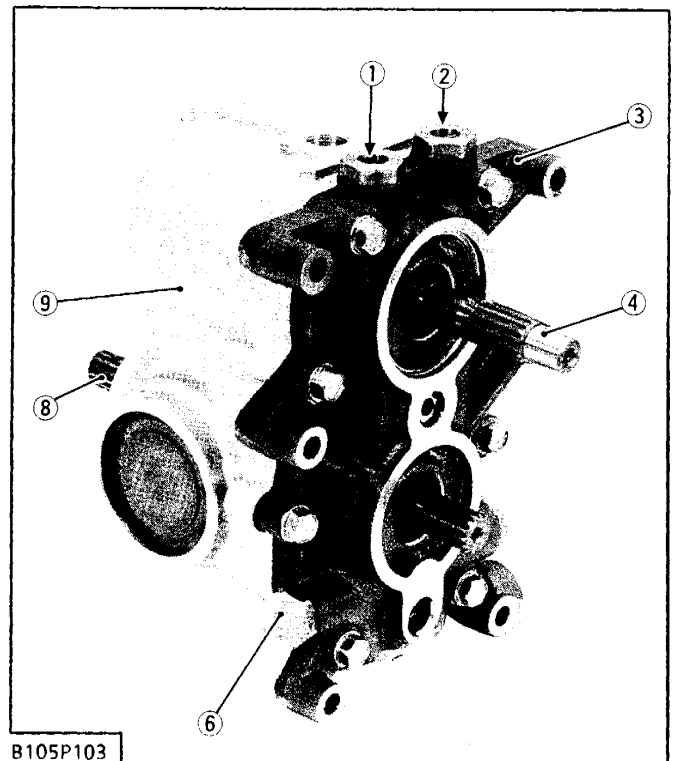

B105P103

- (7) Variable Displacement Piston Pump
- (8) Input Shaft
- (9) Case
- (10) Fixed Displacement Piston Motor

Hydrostatic transmission is composed of variable displacement piston pump, fixed displacement piston

motor and valve system.

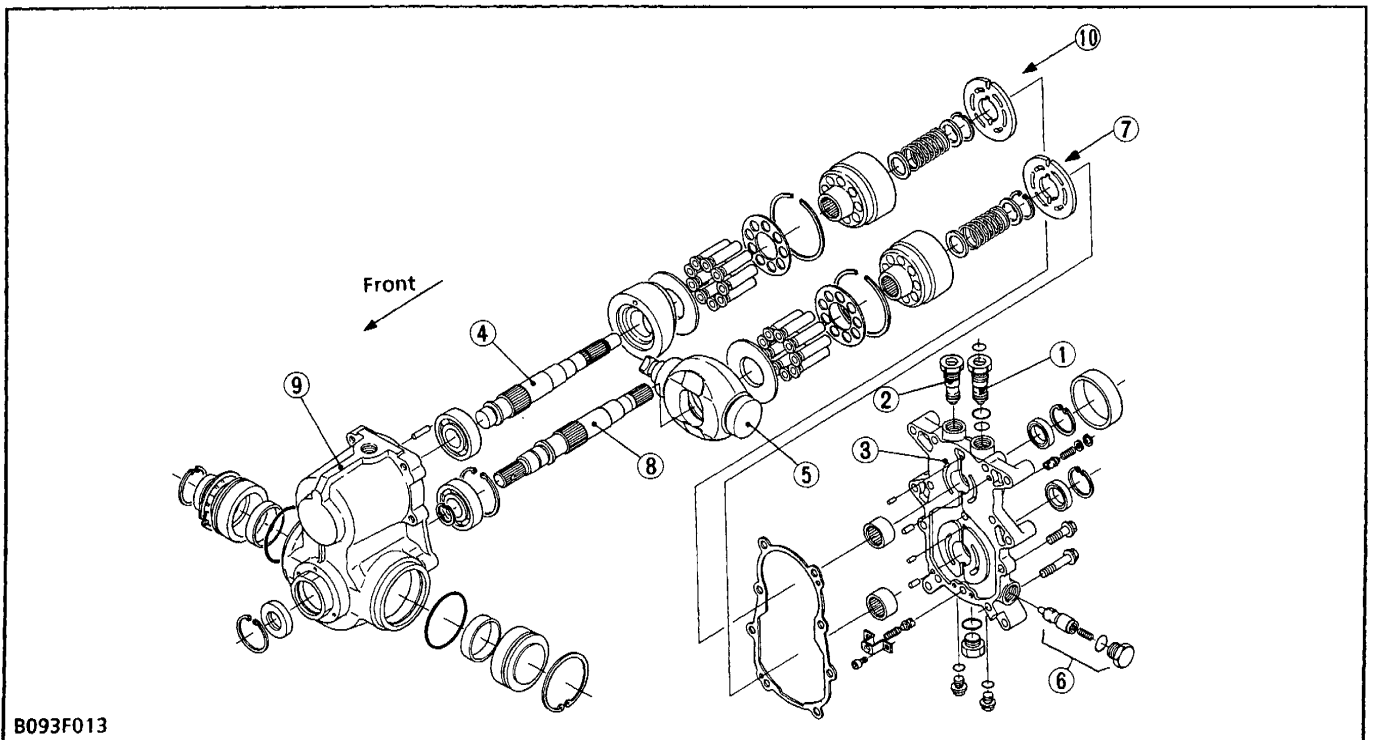

B093F013

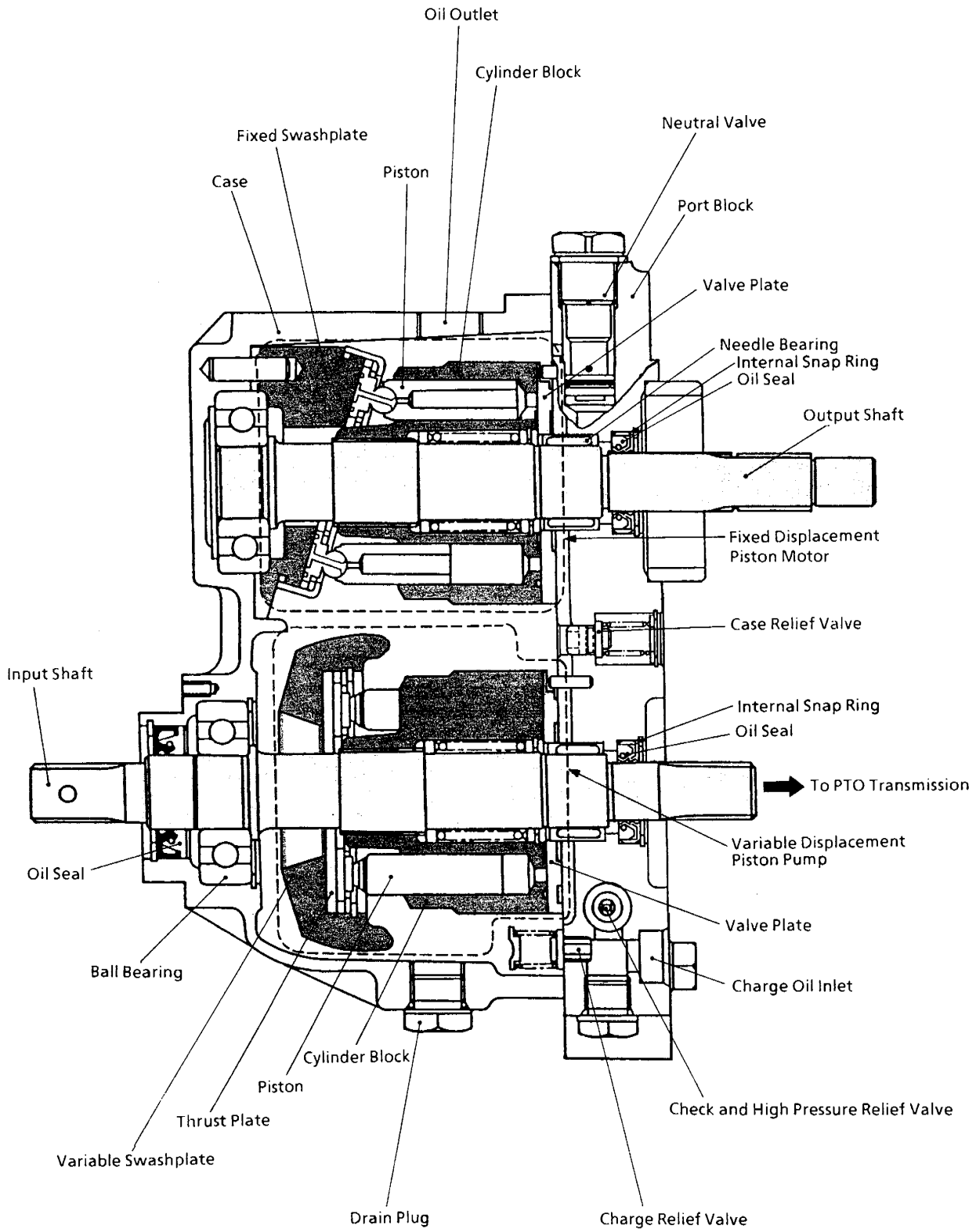

B093F014

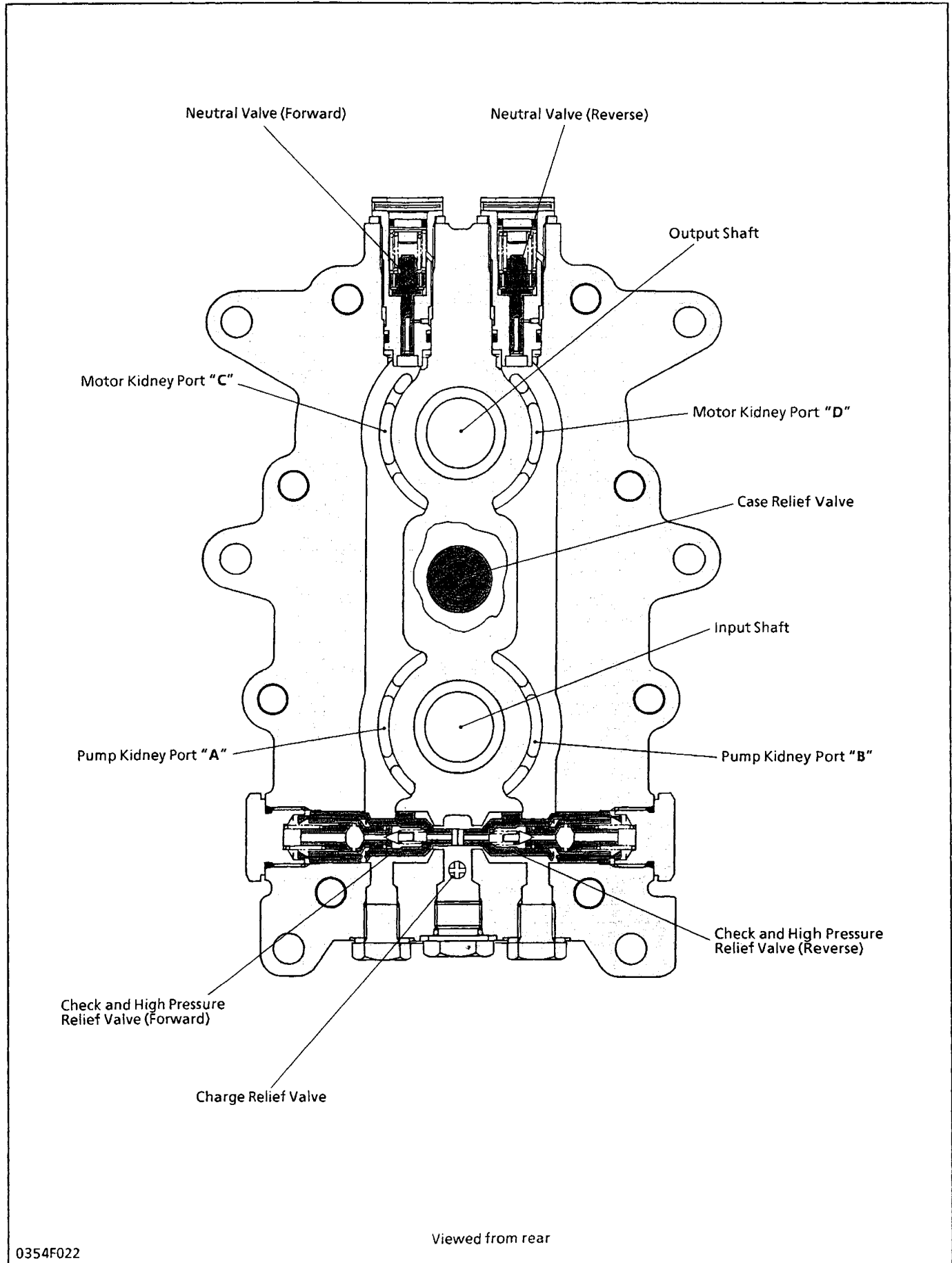

0354F022

2. Pump and Motor

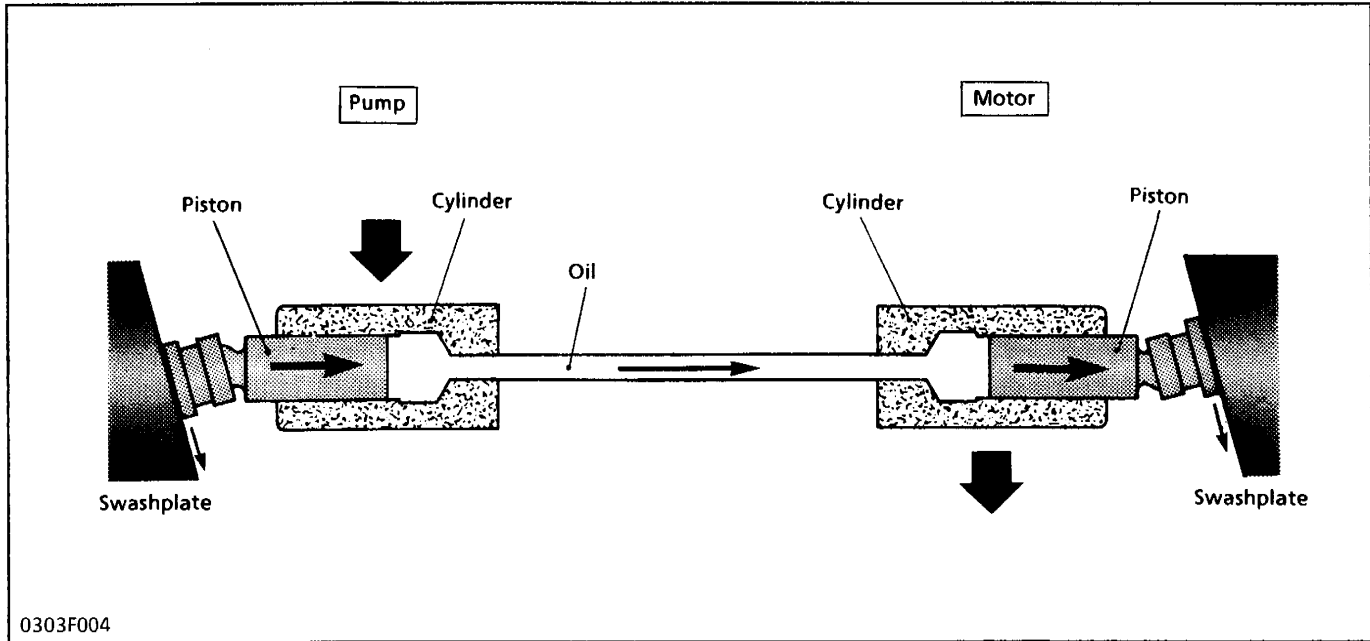

Pump and motor cylinder, each containing pistons, are connected by lines. Cylinders and lines are filled with oil. Pistons ride against swashplates located in pump and motor.

In the pump, as the cylinder rotates, pistons move across the sloping face of swashplate and slide in or

out of their cylinder bores. The oil, forced out by the pump pistons, causes the motor pistons to slide out of their cylinder bores.

In the motor, sliding out of the cylinder and moving across the sloping face of swashplate, the pistons rotate the cylinder.

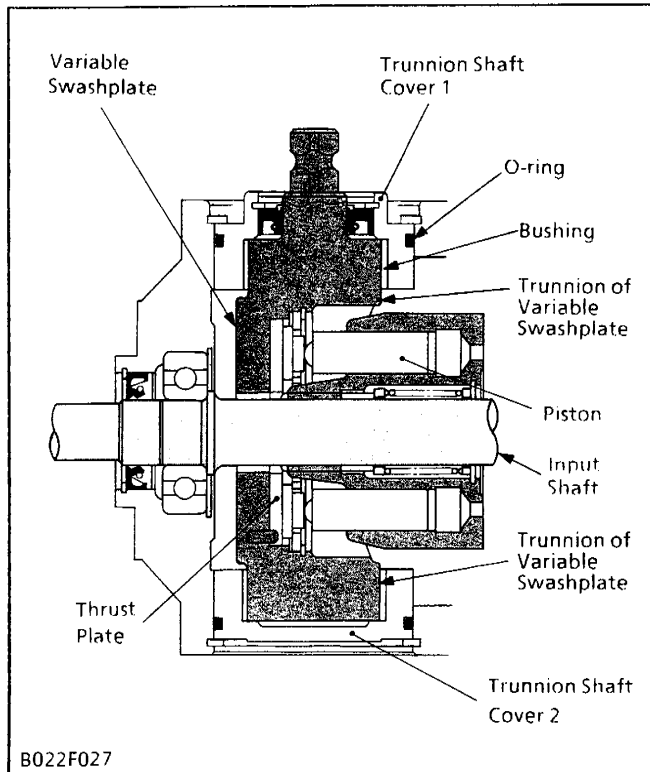

■ Variable Swashplate

This pump is variable displacement one. The angle of its swashplate can be varied so that the volume and pressure of oil pumped by the pistons can be changed or the direction of oil flow can be reversed.

The swashplate is moved around the trunnion shaft with the neutral holder, by stepping on the speed control pedal linked to the neutral holder.

3. Oil Flow and Valves

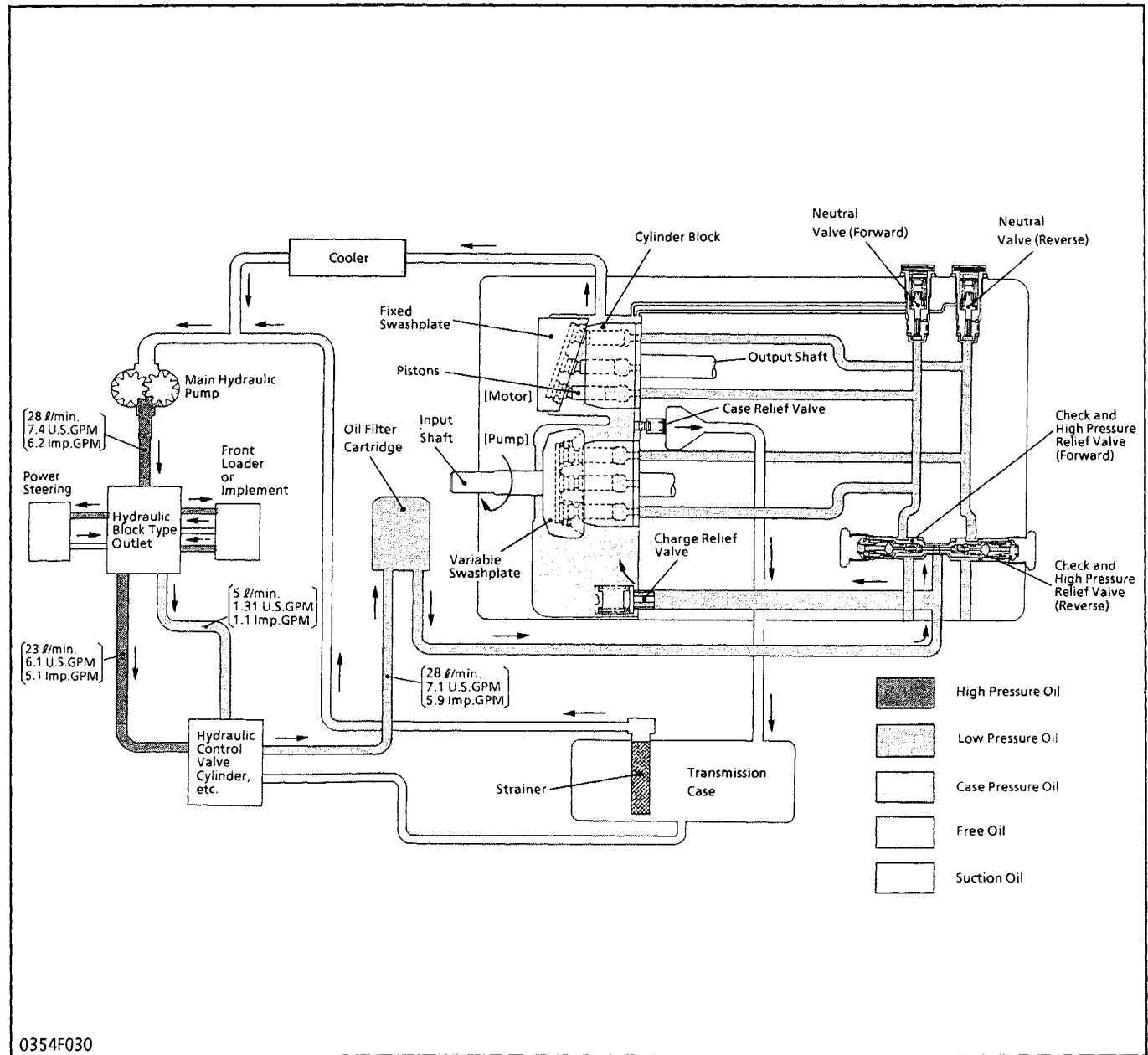

In the hydrostatic transmission, the pump and motor are joined in a closed hydraulic loop and most of oil circulates within the main oil circuit. A little of oil lubricates and oozes out from the clearance between the moving parts to the case. Then oil in the main oil circuit of the hydrostatic transmission needs to be supplied a want. So all of oil fed from the main hydraulic pump flows to the hydrostatic transmission for charging and cooling. Only return oil from the hydraulic cylinders drops to the

transmission case.

The charge oil aids smooth operation of piston pump and motor. The rest of the oil passes through the charge relief valve into the case. Then the about half of oil in the case passes to the main hydraulic pump through a cooler. And the other oil drops to the transmission case through the case relief valve of the hydrostatic transmission, and then the oil is sucked into main hydraulic pump through the oil strainer.

■ Charge Relief Valve

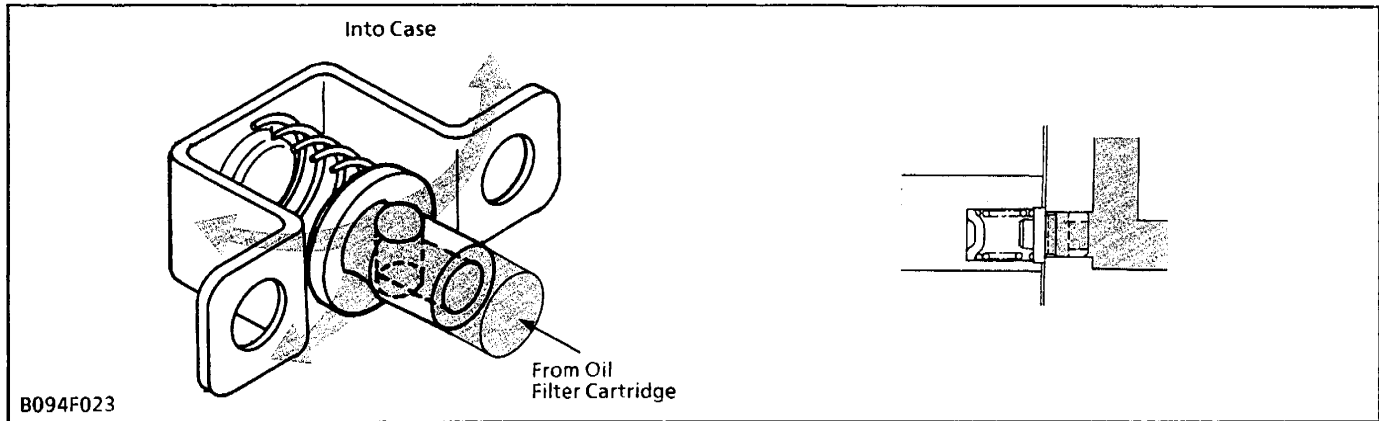

While pumped oil flows into the main oil circuit through the check and high pressure relief valve, excessive oil passes to the case through the charge relief valve.

Oil temperature	Valve operating pressure
50°C (122°F)	490 to 686 kPa (5 to 7 kgf/cm ² , 71 to 100 psi)

■ Neutral Valve

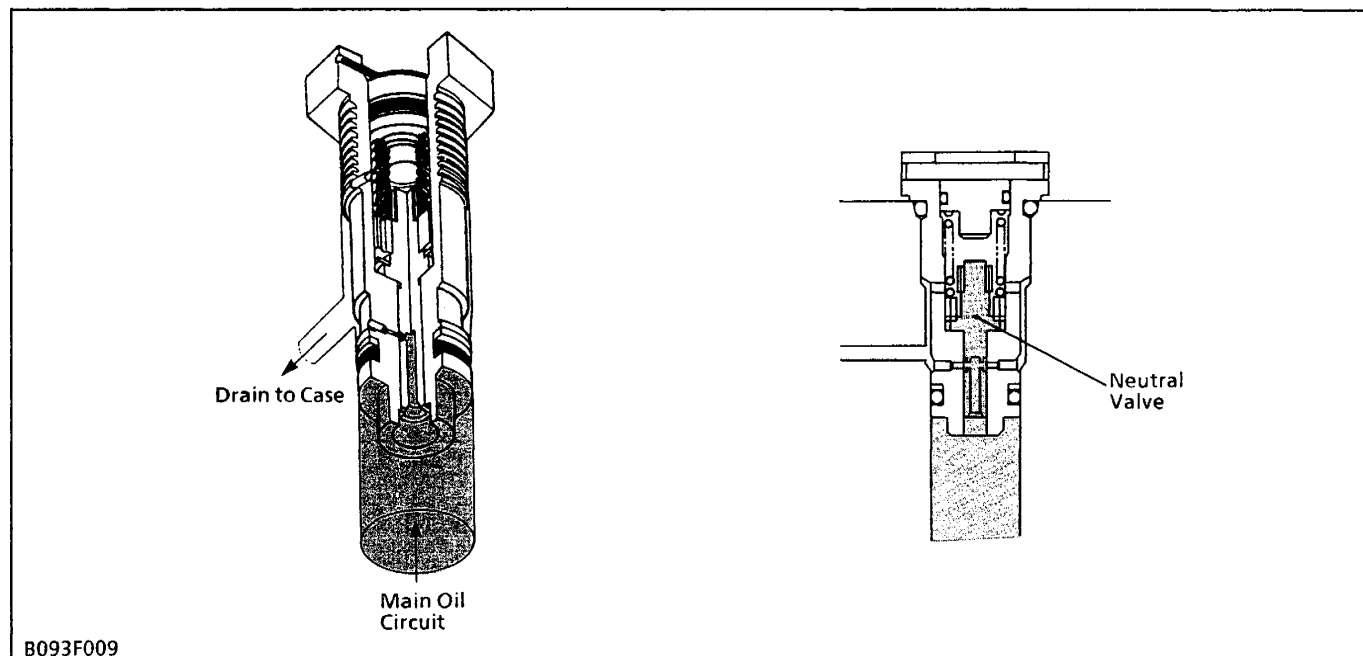

The neutral valves in the main oil circuit are open and return the oil to the case, when neutral and the oil pressure in their line is low.

And when the oil pressure increases to a specified pressure, the neutral valve is closed.

Oil temperature	Valve operating pressure	
	50°C (122°F)	Close
Open		1.5 MPa (15 kgf/cm ² , 213 psi)

■ Check and High Pressure Relief Valve

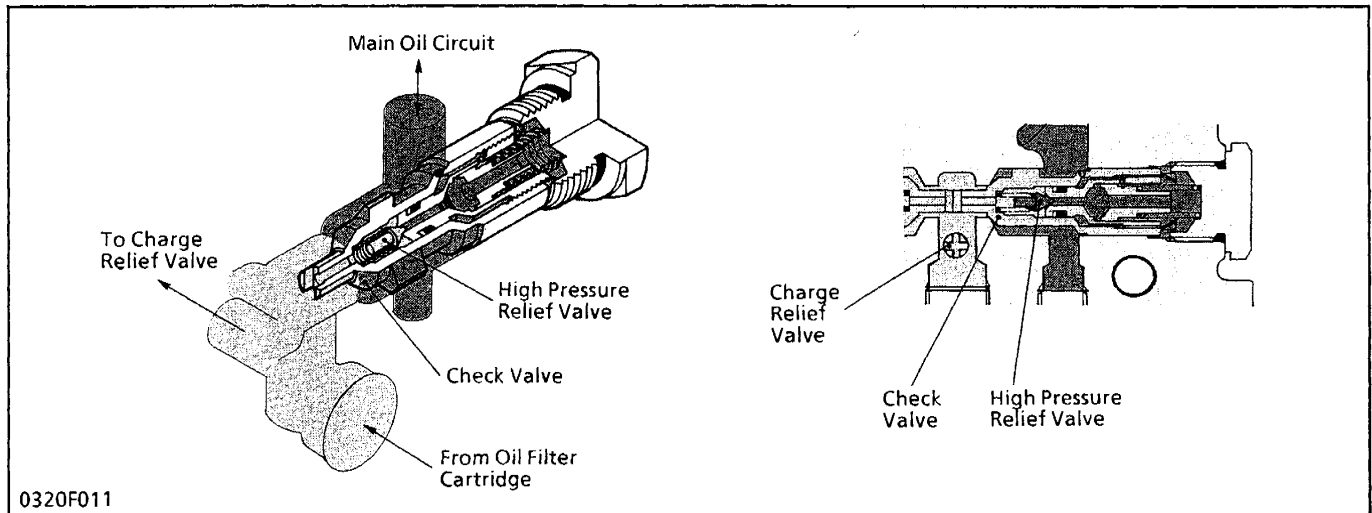

0320F011

The check and high pressure relief valves monitor the oil pressure in each line of the main oil circuit.

In neutral, both valves are open and charging oil enters into the main oil circuit through the valves.

At normal operation, the check valve in the high pressure side is closed and it pushes and opens the another one.

When excessively high pressure is built up in one line, the high pressure relief valve located in this line is open and the oil flows into another line.

Oil temperature	Relief valve operating pressure
50°C (122°F)	27.5 to 28.4 MPa (280 to 290 kgf/cm ² , 3983 to 4125 psi)

■ Case Relief Valve

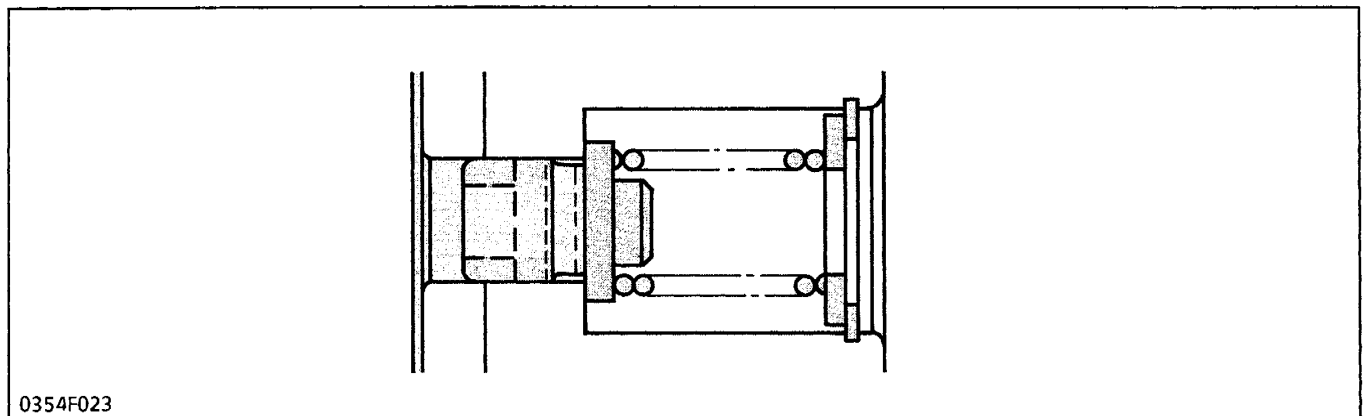

0354F023

The case relief valve monitors the oil pressure in the hydrostatic transmission case. When the oil pressure rises, it opens and the oil flows directly to the transmission case, so that the oil may not leak against the sealings.

Oil temperature	Valve operating pressure
50°C (122°F)	98 to 294 kPa (1 to 3 kgf/cm ² , 14 to 43 psi)

4. Operation

■ Neutral

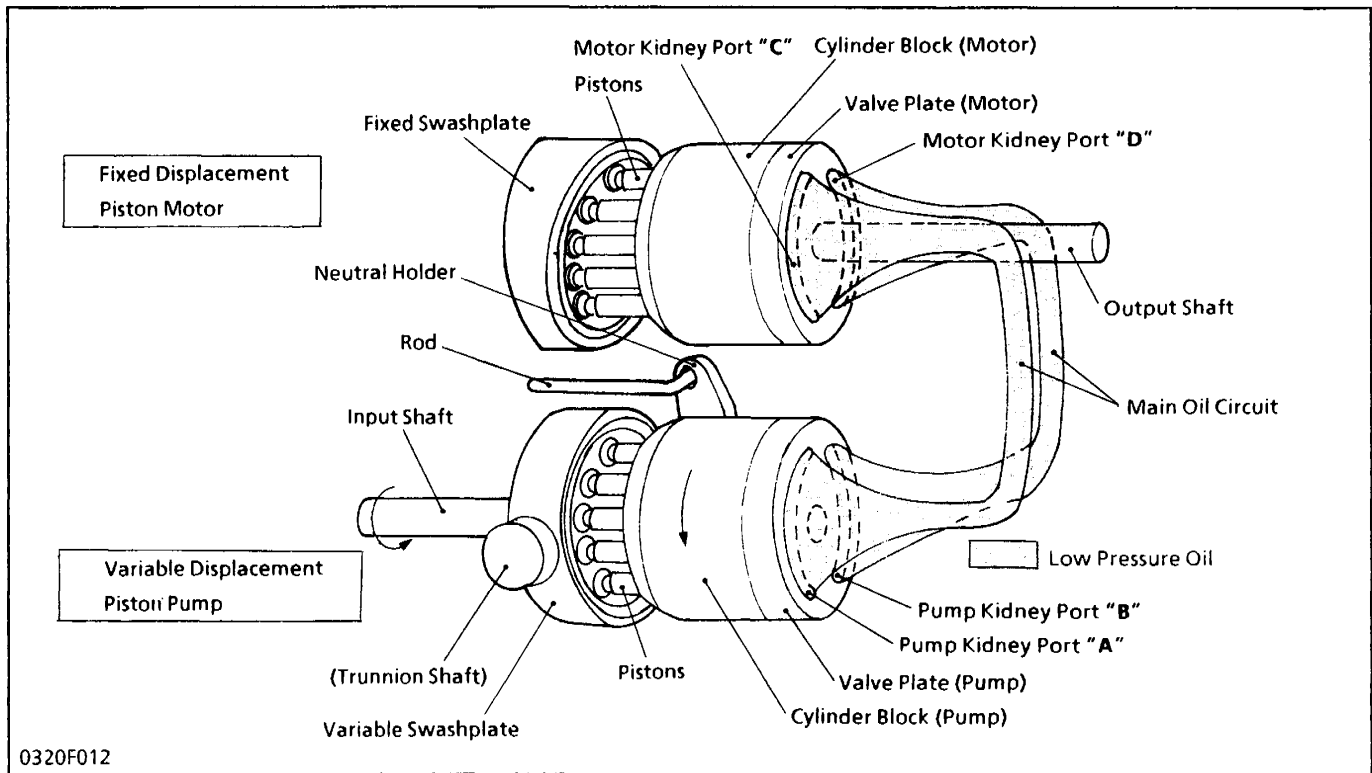

0320F012

When the speed control pedal is in neutral, the variable swashplate is at right angles to the pump pistons and they only rotate with cylinder block without reciprocating. Since the oil is not being

pumped to the motor, the cylinder block in the motor is stationary and the output shaft does not move.

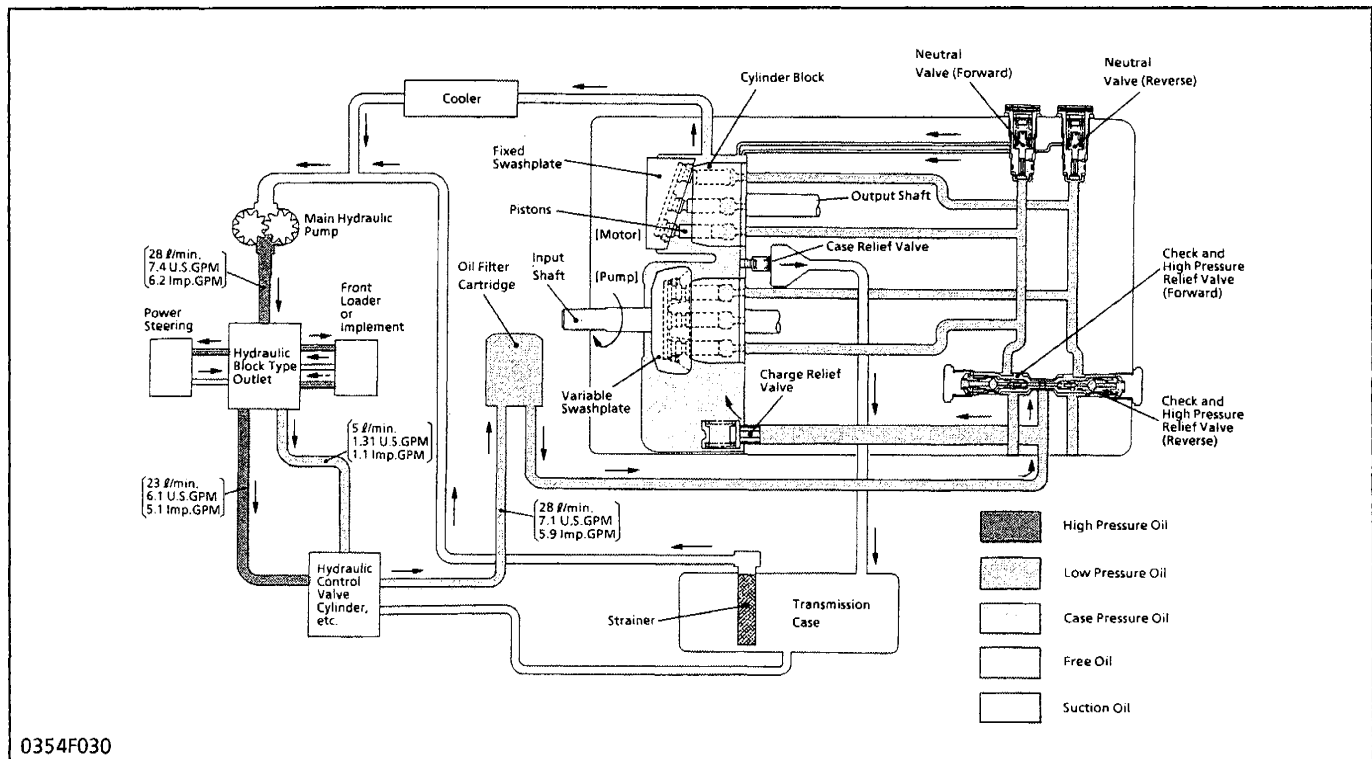

0354F030

■ Neutral

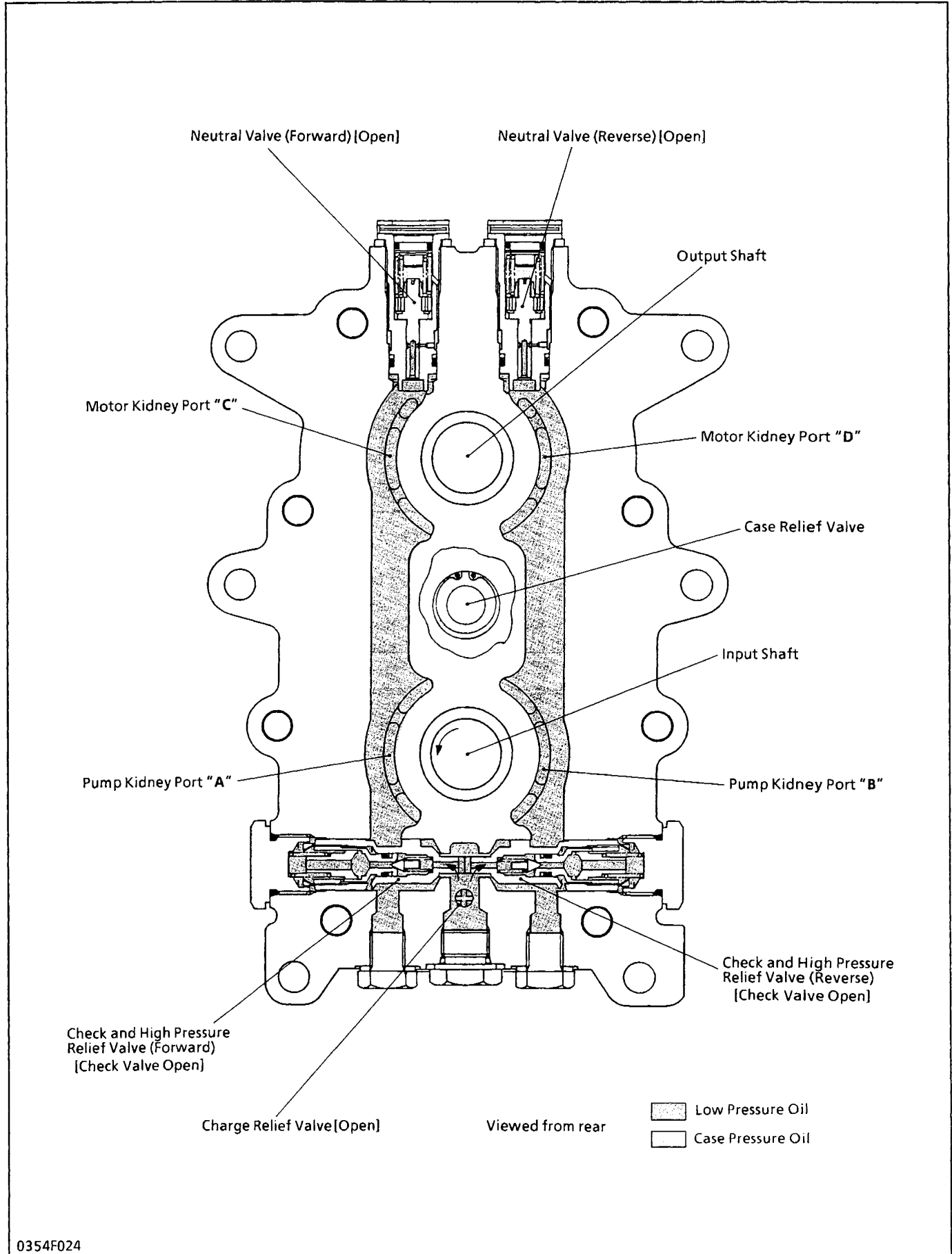

0354F024

■ Forward

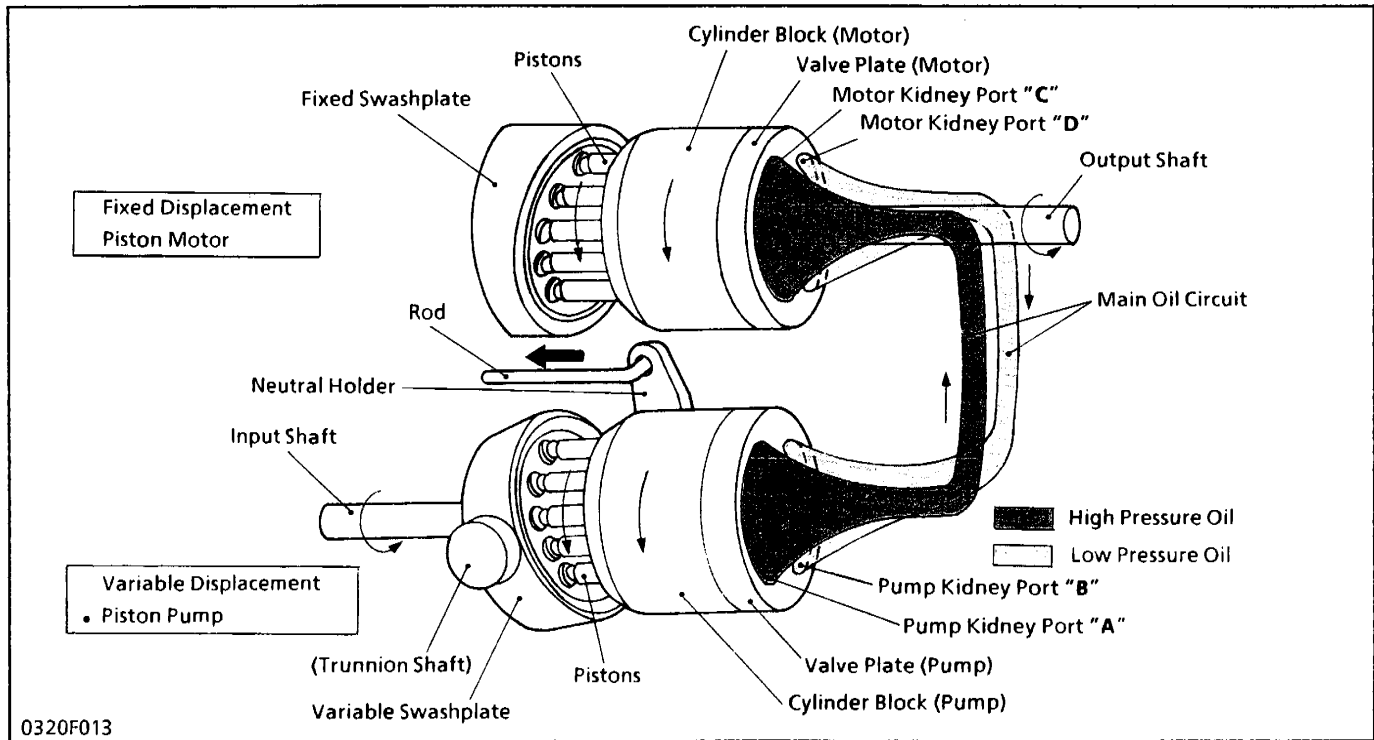

When the speed control pedal is stepped on and in forward, the variable swashplate is tilted as shown in the figure above.

As the pump cylinder block rotates with the input shaft, oil is forced out of pump kidney port "A" at high pressure. As pressure oil enters motor kidney port "C", the pistons, which align with port "C", are pushed against the swashplate and slide down the

inclined surface.

Then the output shaft rotates with the motor cylinder block. This drives the machine forward and the angle of pump swashplate determines the output shaft speed.

As the motor cylinder block continues to rotate, oil is forced out of motor kidney port "D" at low pressure and returns to the pump.

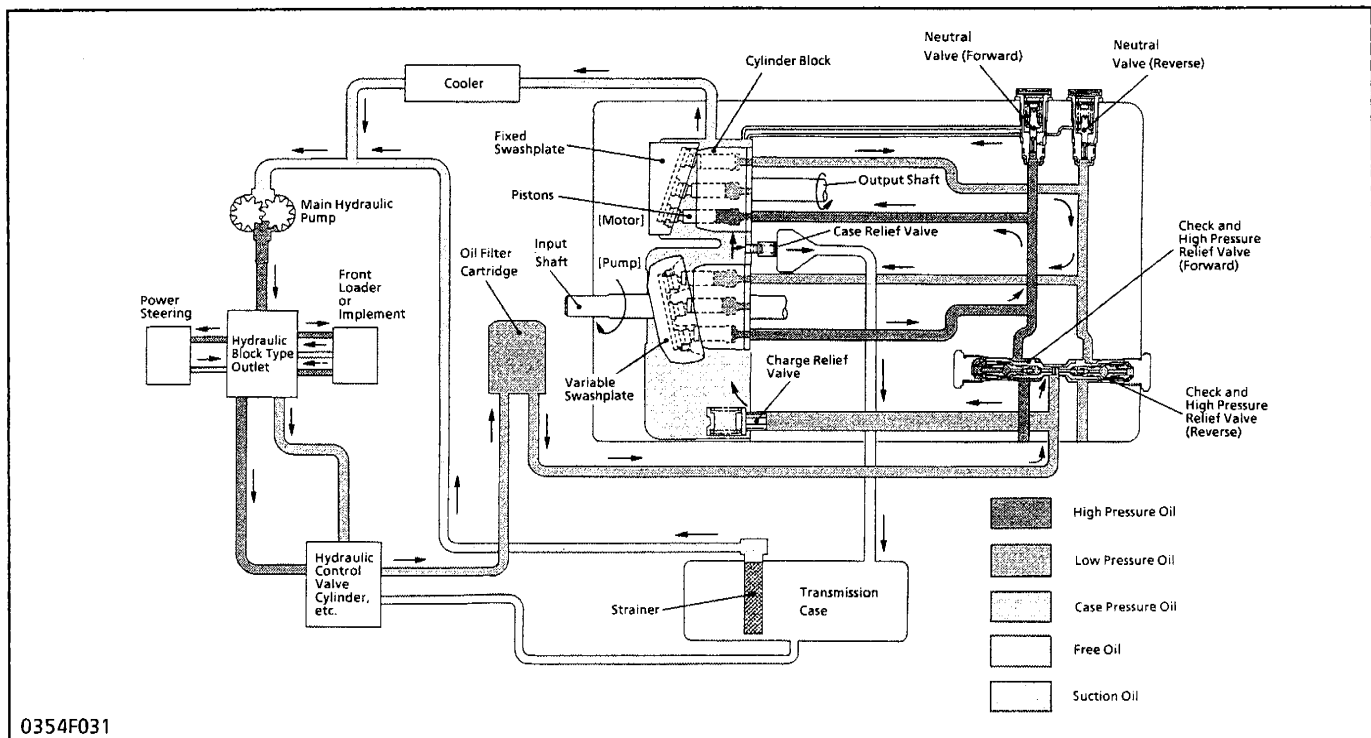

■ Forward

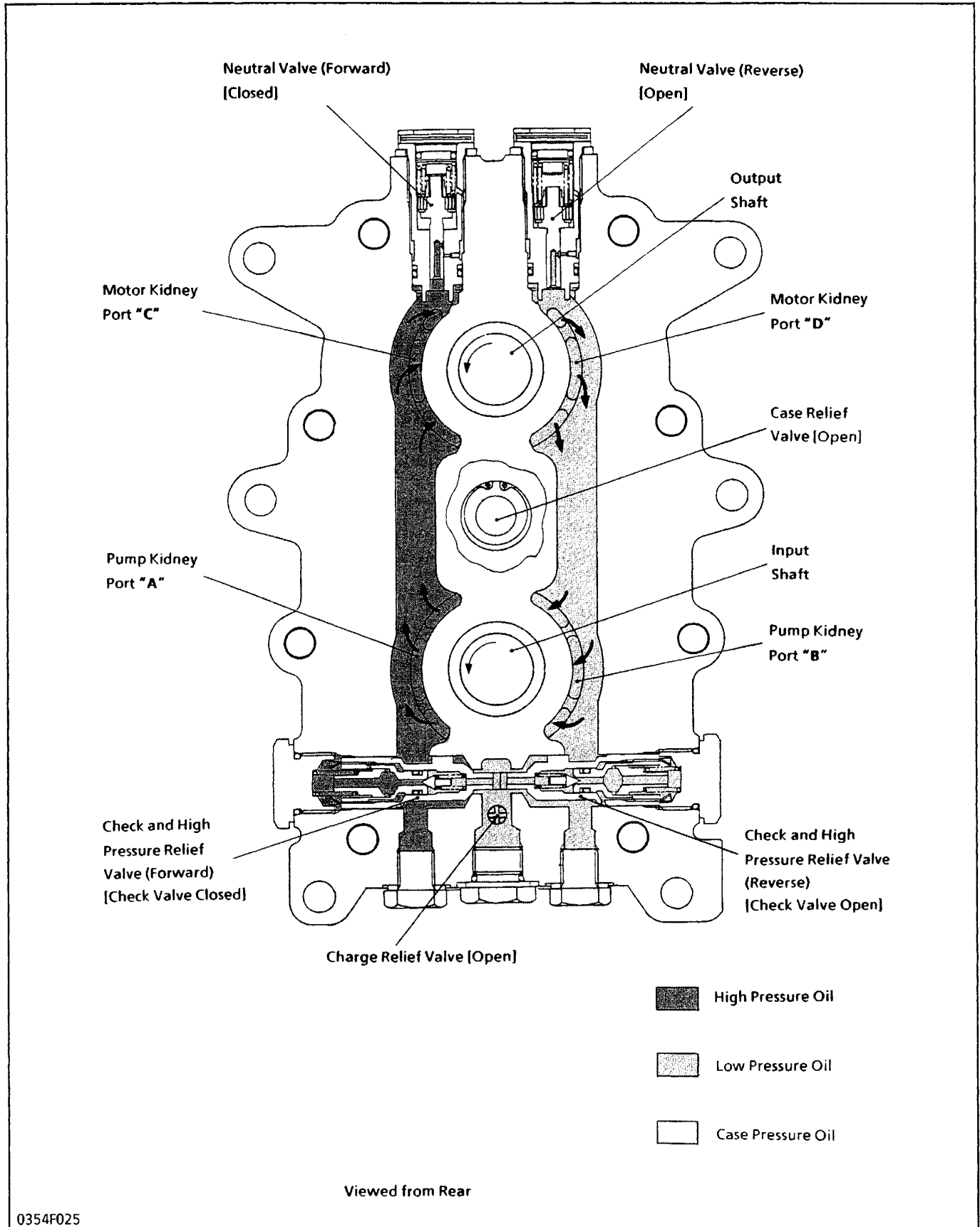

0354F025

Reverse

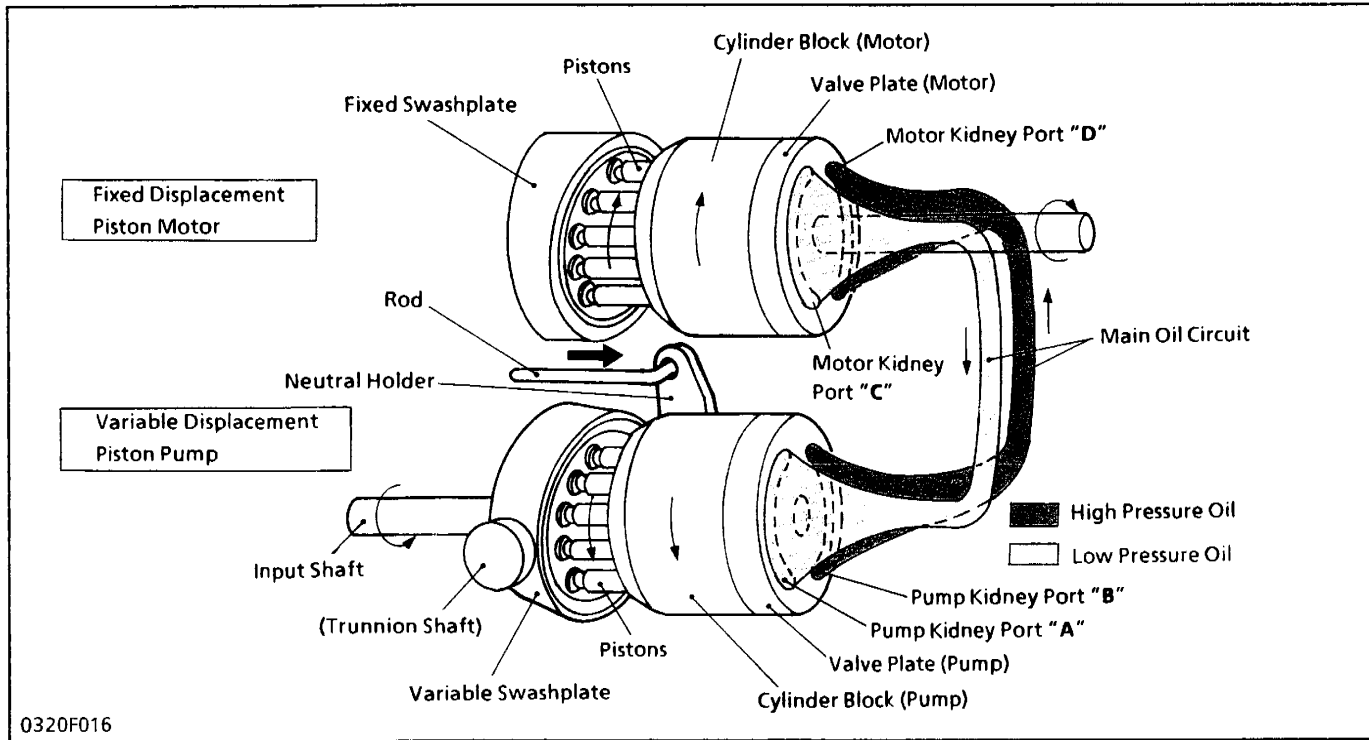

When the speed control pedal is stepped on and in reverse, the variable swashplate is tilted as shown in the figure above.

As the pump cylinder block rotates with the input shaft, oil is forced out of pump kidney port "B" at high pressure. As pressure oil enters motor kidney port "D", the pistons, which align with port "D", are pushed against the swashplate and slide down the

inclined surface.

Then the output shaft rotates with the motor cylinder block. This drives the machine and the angle of pump swashplate determines the output shaft speed.

As the motor cylinder block continues to rotate, oil is forced out of motor kidney port "C" at low pressure and returns to the pump.

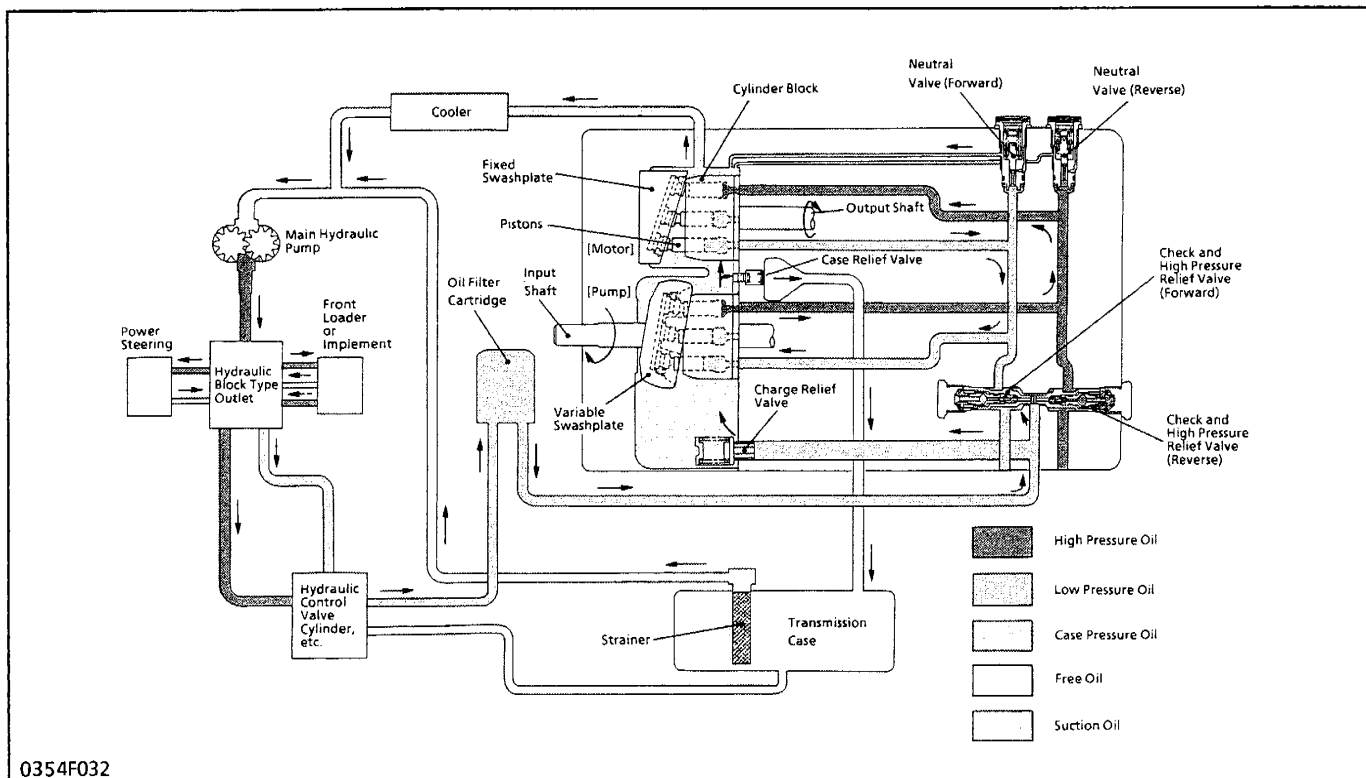

Reverse

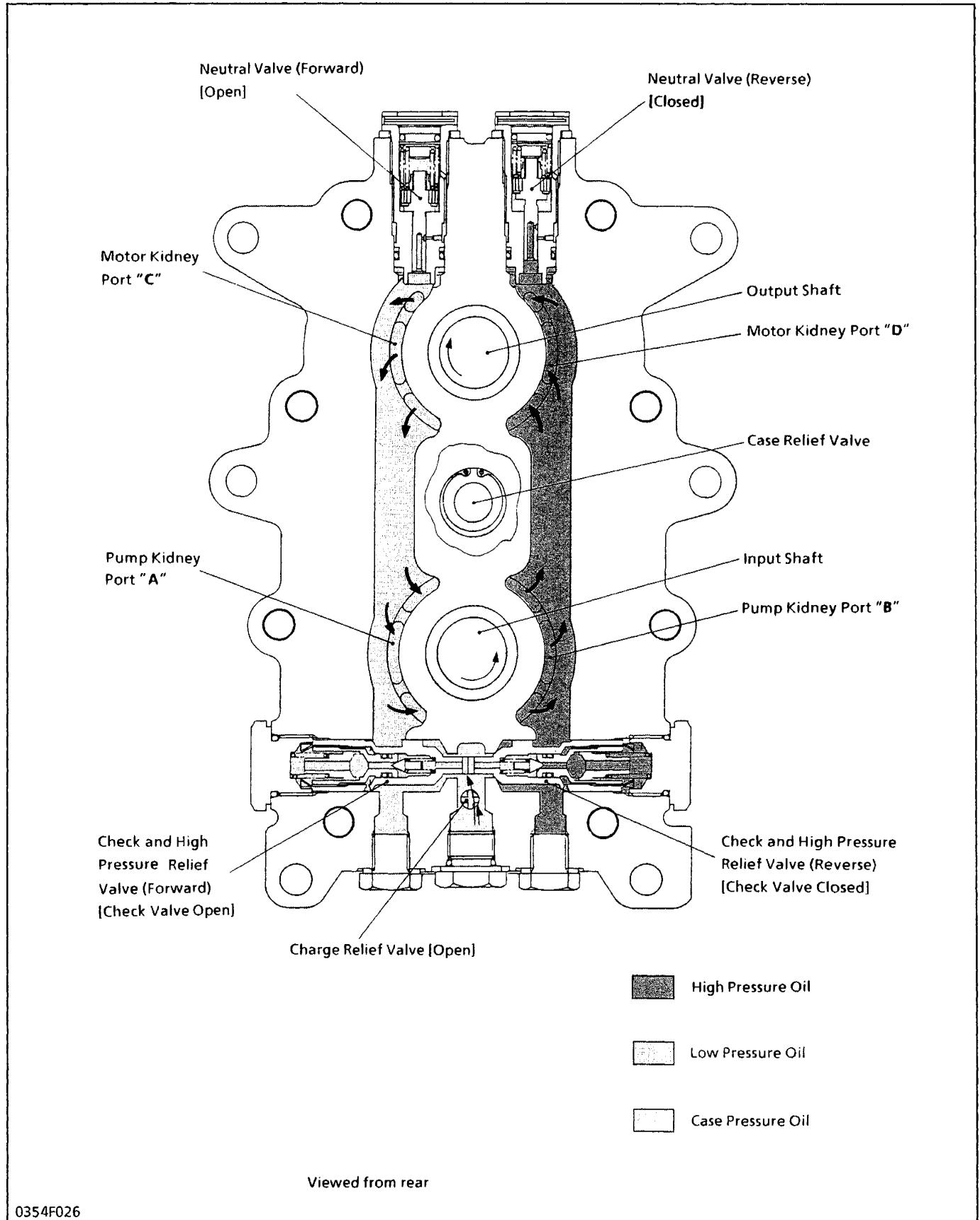

0354F026

5. Control Linkage

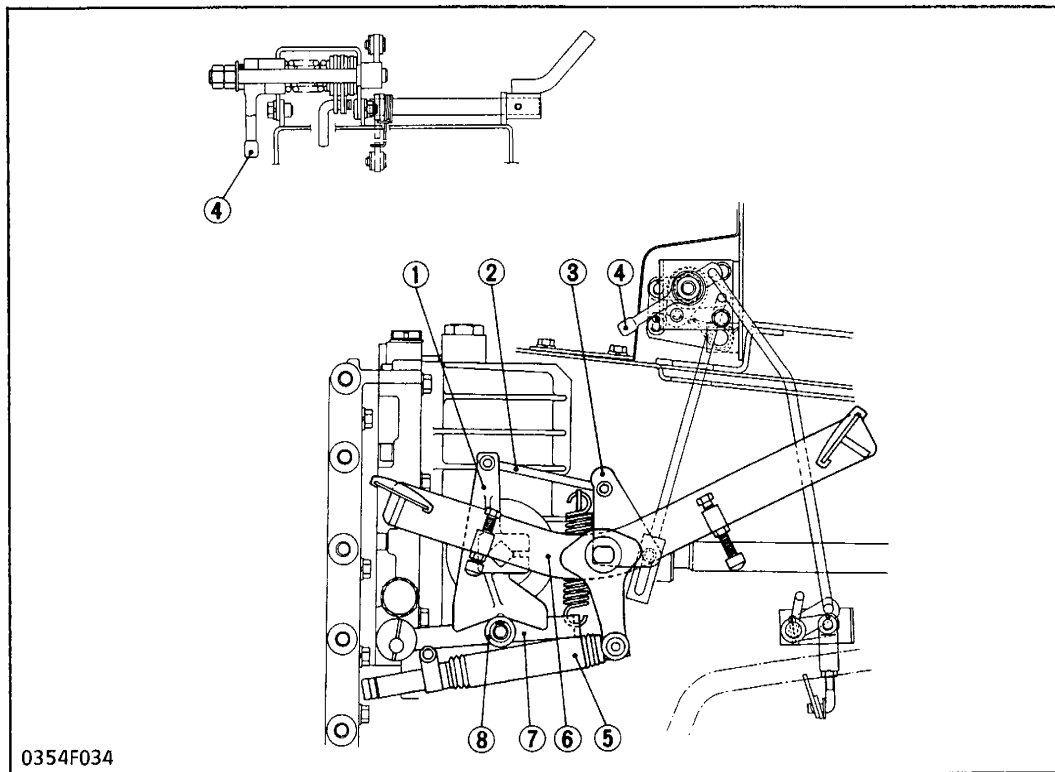

- (1) Neutral Holder
- (2) Speed Control Rod
- (3) Rod Guide
- (4) Speed Set Device
- (5) Damper
- (6) Speed Control Pedal
- (7) Neutral Holder Arm
- (8) Roller

0354F034

The speed control pedal (6) and the trunnion shaft of variable swashplate are linked with the rod guide (3), the speed control rod (2) and the neutral holder (1). As the front footrest of the pedal is depressed, the swashplate rotates and forward traveling speed increases. Depressing the rear footrest increases reverse speed.

The roller (8) on the neutral holder arm (7) hinged with spring seats the detent of the neutral holder(1) so that the neutral holder returns to neutral. Then,

the swashplate is returned to neutral with the neutral holder, when the pedal is released. The damper (5) connected to the rod guide (3) restricts the movement of the linkage to prevent abrupt operation or reversing.

The speed set device (4) linked to the rod guide (3) enables the linkage not to return to neutral and to keep a certain forward speed while the speed control pedal (6) is released.

(3) Auxiliary Gear Shift Section

■ B1550-B1750-B1550HST-B1750HST (L-H range)

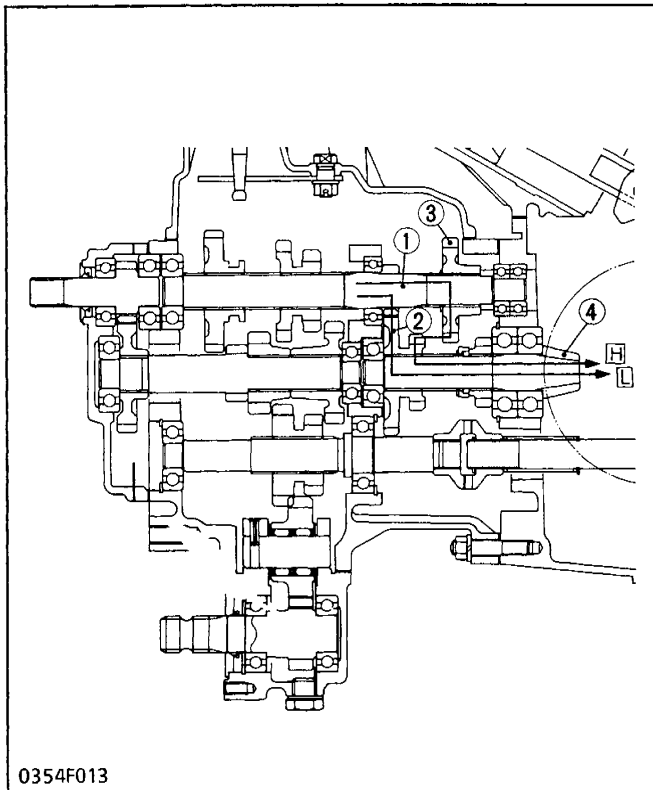

Two kinds of power flow (from 4th shaft to spiral bevel pinion shaft) are available by operating the high-low gear shift lever to shift the gear (2) on the spiral bevel pinion shaft (4)

■ Low Position

4th Shaft (1) → Shifter Gear (2) → Spiral Bevel Pinion Shaft (4)

■ High Position

4th Shaft (1) → Gear (3) → Shifter Gear (2) → Spiral Bevel Pinion Shaft (4)

- (1) 4th Shaft with 11T Gear (15T Gear)
- (2) 32T-13T Shifter Gear (20T-12T Shifter Gear)
- (3) 19T Gear (23T Gear)
- (4) Spiral Bevel Pinion Shaft

*() means the parts for HST type.

■ B2150-B2150HST (L-M-H range)

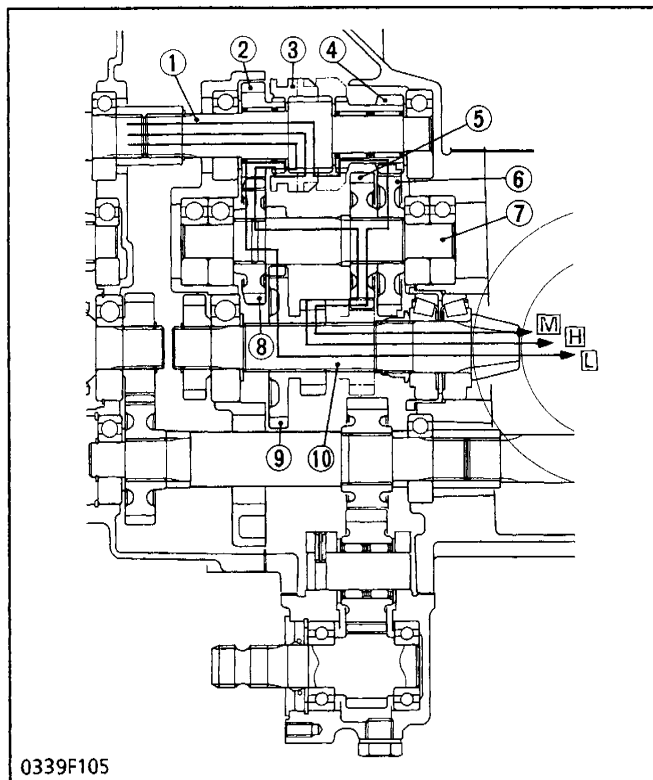

Three kinds of power flow (from 3rd shaft to spiral bevel pinion shaft) are selected by operating the range selector lever to shift position of shifter (3) and gear (9).

■ Low Position

3rd Shaft (1) → Shifter (3) → 18T Gear (2) → Gear (8) → 4th Shaft with 11T Gear (7) → Shifter Gear (9) → Spiral Bevel Pinion Shaft (10)

■ Middle Position

3rd Shaft (1) → Shifter (3) → Gear (4) → 27T Gear (6) → 4th Shaft (7) → Gear (5) → Shifter Gear (9) → Spiral Bevel Pinion Shaft (10)

■ High Position

3rd Shaft (1) → Shifter (3) → 18T Gear (2) → Gear (8) → 4th Shaft (7) → Gear (5) → Shifter Gear (9) → Spiral Bevel Pinion Shaft (10)

- | | |
|-------------------------|--------------------------------|
| (1) 3rd Shaft | (7) 4th Shaft with 11T Gear |
| (2) 18T Gear | (8) 22T Gear (21T Gear) |
| (3) Shifter | (9) 29T-15T Shifter Gear |
| (4) 13T Gear (12T Gear) | (29T-16T Shifter Gear) |
| (5) 25T Gear (24T Gear) | (10) Spiral Bevel Pinion Shaft |
| (6) 27T Gear | |

*() means the parts for HST type.

(4) Front Wheel Drive Section (4WD Type Only)

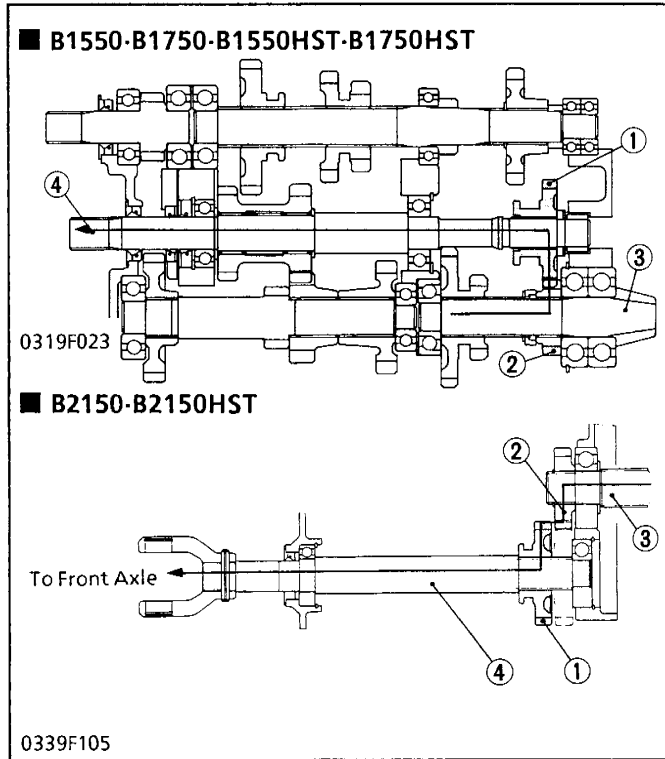

2-wheel drive or 4-wheel drive is selected by changing the position of gear (1) with the front wheel drive lever. When the front wheel drive lever is set to "Disengaged," the gear (1) is neutral and power is not transmitted to the drive shaft (4).

When the front wheel drive lever is set to "Engaged," the gear (1) slides to the right to engage with gear (2) on the spiral bevel pinion shaft (3). Therefore, the front drive shaft is actuated to drive the front wheels.

	B1550 B1750	B1550HST B1750HST	B2150	B2150HST
(1)	23T Gear	23T Gear	27T Gear	27T Gear
(2)	16T Gear	16T Gear	16T Gear	16T Gear
(3)	Spiral Bevel Pinion Shaft			
(4)	Reverse Shaft (Front Drive Shaft)			

[2] PTO SYSTEM

(1) Rear PTO Shift Section

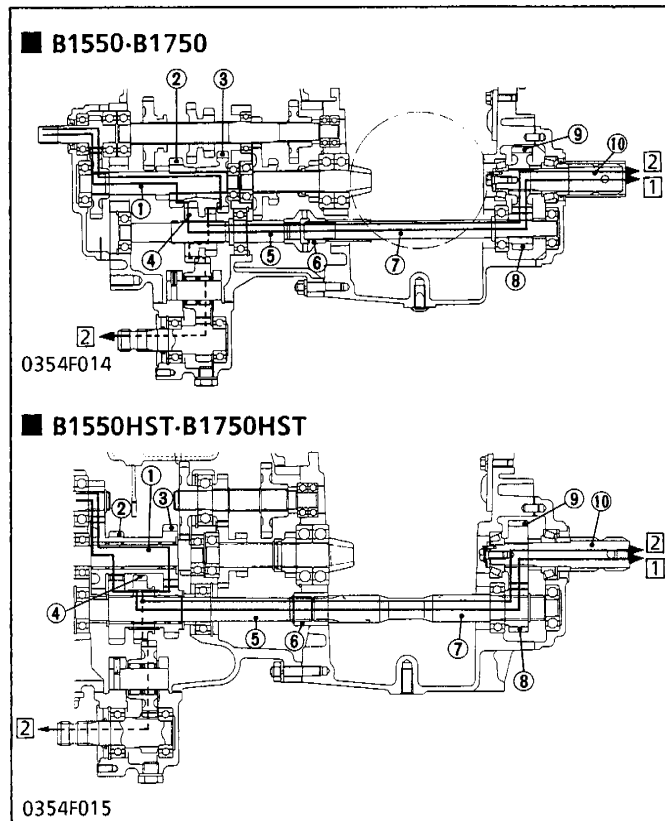

Besides neutral, two kinds of power flow are available by operating the PTO shift lever to shift positions of gear (4).

■ 1st Position

(1st Shaft) 14T Gear → 29T Gear → 2nd Shaft (1) → Gear (2) → Shifter Gear (4) → 3rd Shaft (5) → (6) → 5th Shaft (7) → Gear (8) → Gear (9) → PTO Shaft (10)

■ 2nd Position

(1st Shaft) 14T Gear → 29T Gear → 2nd Shaft (1) → 17T Gear (2) → Shifter Gear (4) → 3rd Shaft (5) → (6) → 5th Shaft (7) → Gear (8) → Gear (9) → PTO Shaft (10)

	B1550-1750	B1550HST-B1750HST
(1)	2nd Shaft	2nd Shaft
(2)	13T Gear	14T Gear
(3)	17T Gear	18T Gear
(4)	13T-17T Shifter Gear	21T Shifter Gear
(5)	3rd Shaft	3rd Shaft
(6)	One-way Clutch Cam	Coupling
(7)	5th Shaft	5th Shaft
(8)	13T Gear	14T Gear
(9)	22T Gear	21T Gear
(10)	PTO Shaft	PTO Shaft

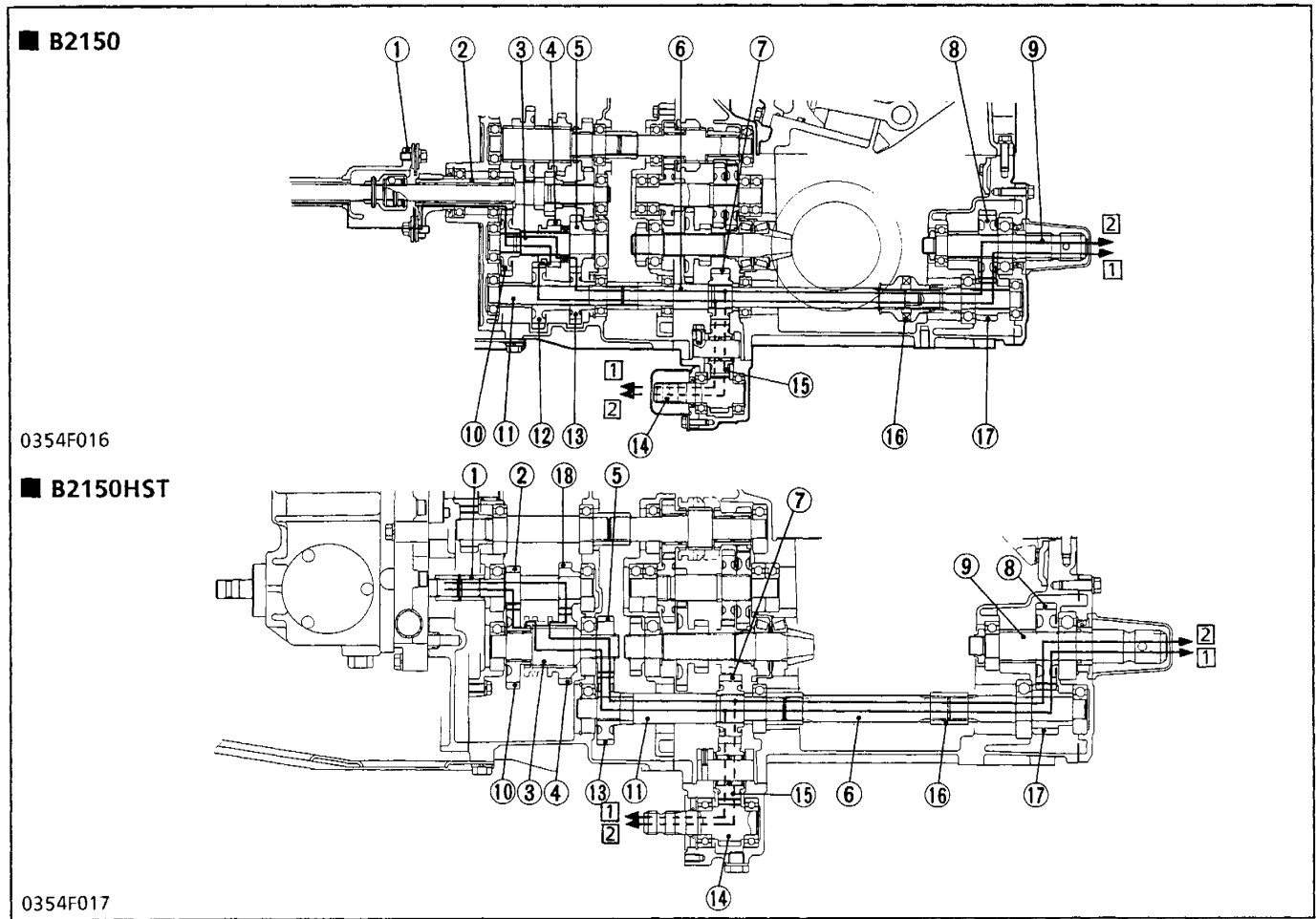

Two kinds of power flow are selected by operating the PTO gear shift lever to shift position of gear (4).

1st Position

(Rear PTO)

[B2150]

Coupling (1)→Shaft with 15T Gear (2)→25T Gear (10)→6th Shaft (3)→17T Shifter Gear (4)→25T Gear (12)→7th Shaft Front (11)→7th Shaft Middle (6)→One-way Clutch Cam (16)→7th Shaft Rear with 15T Gear (17)→28T Gear (8)→Rear PTO Shaft (9)

[B2150HST]

(1)→(2)→(10)→(4)→(3)→(5)→(13)→(11)→(6)→(16)→(17)→(8)→(9)

2nd Position

(Rear PTO)

[B2150]

Coupling (1)→Shaft with 15T Gear (2)→25T Gear (10)→6th Shaft (3)→17T Shifter Gear (4)→20T Gear (5)→21T Gear (13)→7th Shaft Front (11)→7th Shaft Middle (6)→One-way Clutch Cam (16)→7th Shaft Rear with 15T Gear (17)→28T Gear (8)→Rear PTO Shaft (9)

[B2150HST]

(1)→(2)→(18)→(4)→(3)→(5)→(13)→(11)→(6)→(16)→(17)→(8)→(9)

	B2150	B2150HST
(1)	Coupling	Coupling
(2)	Outer Shaft with 15T Gear	1st Shaft with 13T Gear
(3)	6th Shaft	6th Shaft
(4)	17T Shifter Gear	24T Shifter Gear
(5)	20T Gear	20T Gear
(6)	7th Shaft Middle	7th Shaft Middle
(7)	27T Gear	27T Gear
(8)	28T Gear	28T Gear
(9)	Rear PTO Shaft	Rear PTO Shaft
(10)	25T Gear	27T Gear
(11)	7th Shaft Front	7th Shaft Front
(12)	25T Gear	—
(13)	21T Gear	23T Gear
(14)	Mid PTO Shaft with 16T Gear	Mid PTO Shaft with 16T Gear
(15)	27T Gear	27T Gear
(16)	One-way Clutch Cam	Coupling
(17)	7th Shaft Rear with 15T Gear	7th Shaft Rear with 15T Gear
(18)	—	16T Gear

(2) MID PTO Section

The mid PTO is mounted on all tractors as a standard.

[B1550·B1750·B1550HST·B1750HST]

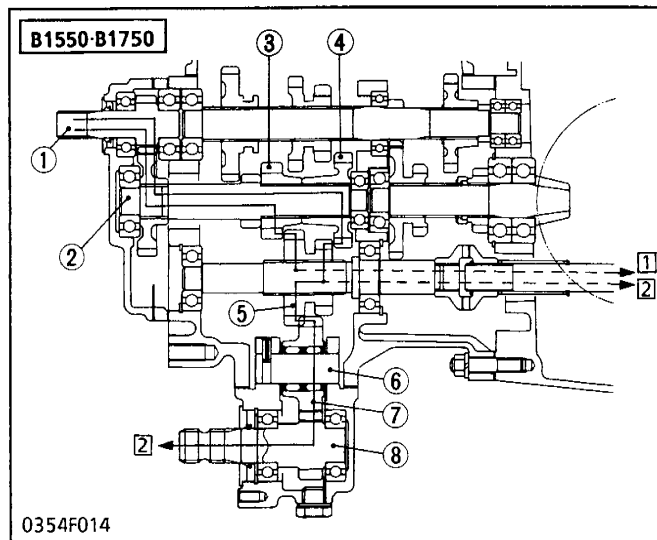

Besides neutral, one kind of power flow are available by operating the PTO shift lever to shift positions of shifter gear for Mid PTO.

Always the mid PTO is engaged with the rear PTO, selecting the 2nd position.

■ 1st Position

The mid PTO is not engaged with the shifter gear.

■ 2nd Position

1st Shaft (14T Gear) (1)→29T Gear→2nd Shaft (2)→Gear (4)→Shifter Gear (5)→3rd Shaft (6)→Gear (7)→Mid PTO Shaft with 11T Gear (8)

- | | |
|--------------------------|---------------------------------|
| (1) 1st Shaft (14T Gear) | (5) 13T-17T Shifter Gear |
| (2) 2nd Shaft | (21T Shifter) |
| (3) 13T Gear (14T Gear) | (6) 3rd Shaft |
| (4) 17T Gear (18T Gear) | (7) 19T Gear (24T Gear) |
| | (8) Mid PTO Shaft with 11T Gear |

* () means the parts for HST type.

[B2150·B2150HST]

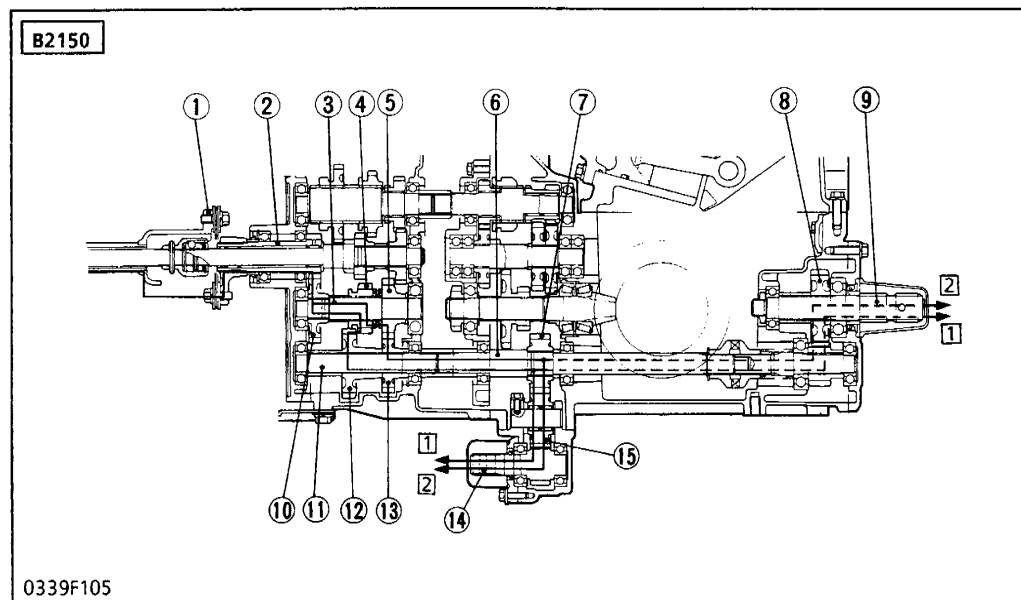

- | |
|---|
| (1) Coupling |
| (2) Outer Shaft with 15T Gear |
| (3) 6th Shaft |
| (4) 17T Shifter Gear (24T Shifter Gear) |
| (5) 20T Gear |
| (6) 7th Shaft Middle |
| (7) 27T Gear |
| (8) 28T Gear |
| (9) Rear PTO Shaft |
| (10) 25T Gear (27T Gear) |
| (11) 7th Shaft Front |
| (12) 25T Gear (None) |
| (13) 21T Gear (23T Gear) |
| (14) Mid PTO Shaft with 16T Gear |
| (15) 27T Gear |
| (18) None (20T Gear) |

* () means the parts for HST type.

Two kinds of power flow are selected by operating the PTO gear shift lever to shift position of 17T gear (5). Always the mid PTO is engaged with rear PTO.

■ 1st Position

[B2150]

Coupling (1)→Outer Shaft with 15T Gear (2)→25T Gear (10)→6th Shaft (3)→17T Gear (4)→25T Gear (12)→7th Shaft Front (11)→7th Shaft Middle (6)→27T Gear (7)→27T Gear (15)→Mid PTO Shaft with 16T Gear (14)

[B2150HST]

(1)→(2)→(10)→(4)→(3)→(5)→(13)→(11)→(7)→(15)→(14)

■ 2nd Position

[B2150]

Coupling (1)→Outer Shaft with 15T Gear (2)→25T Gear (10)→6th Shaft (3)→17T Gear (4)→20T Gear (5)→21T Gear (13)→7th Shaft Front (11)→7th Shaft Middle (6)→27T Gear (7)→27T Gear (16)→Mid PTO Shaft with 16T Gear (14)

[B2150HST]

(1)→(2)→(18)→(4)→(3)→(5)→(13)→(11)→(7)→(15)→(14)

		B1550-1750 B1550HST.B1750HST	B2150 B2150HST
1st	Rear PTO	540 rpm	540 rpm
	Mid PTO	—	1701 rpm
2nd	Rear PTO	924 rpm	755 rpm
	Mid PTO	2416 rpm	2379 rpm

(3) Front PTO Section

The front PTO is available for all tractors as an option.

Front PTO revolution	Engine revolution (Idling speed to Max. speed)
----------------------	---

(4) One-way Clutch Cam Section (B1550-B1750-B2150)

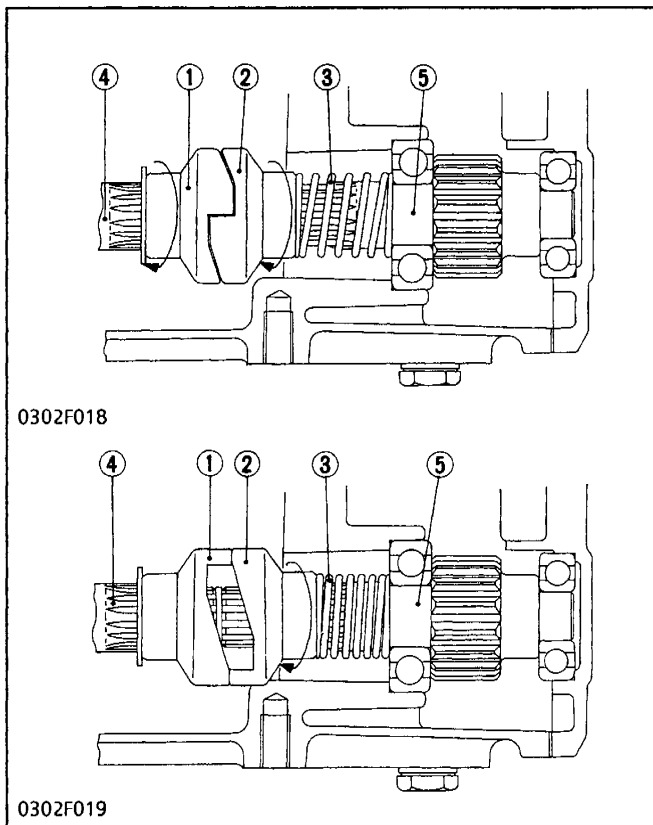

The one-way clutch cam is also called an overrunning clutch. It is composed of a pair of clutch cams(1), (2) and a cam spring (3). One of the clutch cam is splined to the shaft (4), and the other is splined to the shaft (5).

These two clutch cams (1), (2) are engaged with each other by the force of the cam spring. As long as the shaft (4) is rotating faster than the shaft (5), these two clutch cams (1), (2) will remain engaged, and the shaft (5) is driven.

But, if the PTO shaft drives a rotary mower as an implement , for example, and the source of power is stopped by pressing the clutch pedal, or if the engine speed is lowered, the clutch cam (2) will overrun as shown in the figure. This overrunning is caused by the inertia of the mower blades. Then, engagement will not take place until the shaft (4) is running faster than the shaft (5).

In this way, the one-way clutch cam protects the transmission and engine power train against damage, by allowing the PTO shaft and the shaft (5) to overrun if PTO shaft overspeeds.

- (1) Clutch Cam
- (2) Clutch Cam
- (3) Cam Spring
- (4) Middle Shaft
- (5) Rear Shaft

NOTE

- This is not mounted on all HST models.

4 REAR AXLE

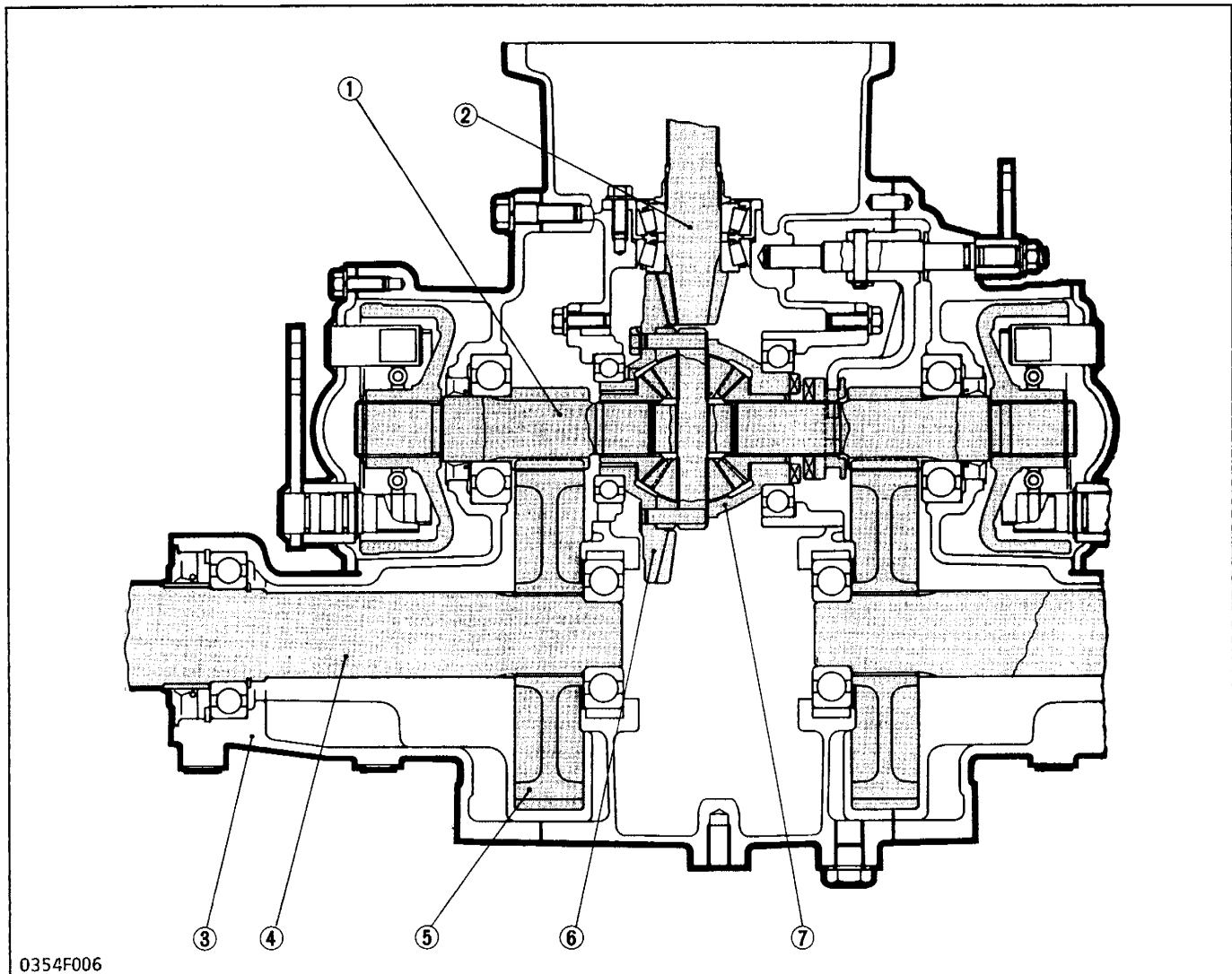

0354F006

(1) Differential Gear Shaft
(2) Spiral Bevel Pinion

(3) Rear Axle Case
(4) Rear Axle

(5) Spur Gear
(6) Spiral Bevel Gear

(7) Differential

The rear axle is a semifloating type with ball bearings between the rear axle (4) and the rear axle case (3), which supports the rear wheel load as well as transmitting power to the rear wheels.

The differential (7) automatically controls the revolution of right and left wheels when the rear wheels encounter unequal road resistance during turning.

[1] DIFFERENTIAL FUNCTIONING

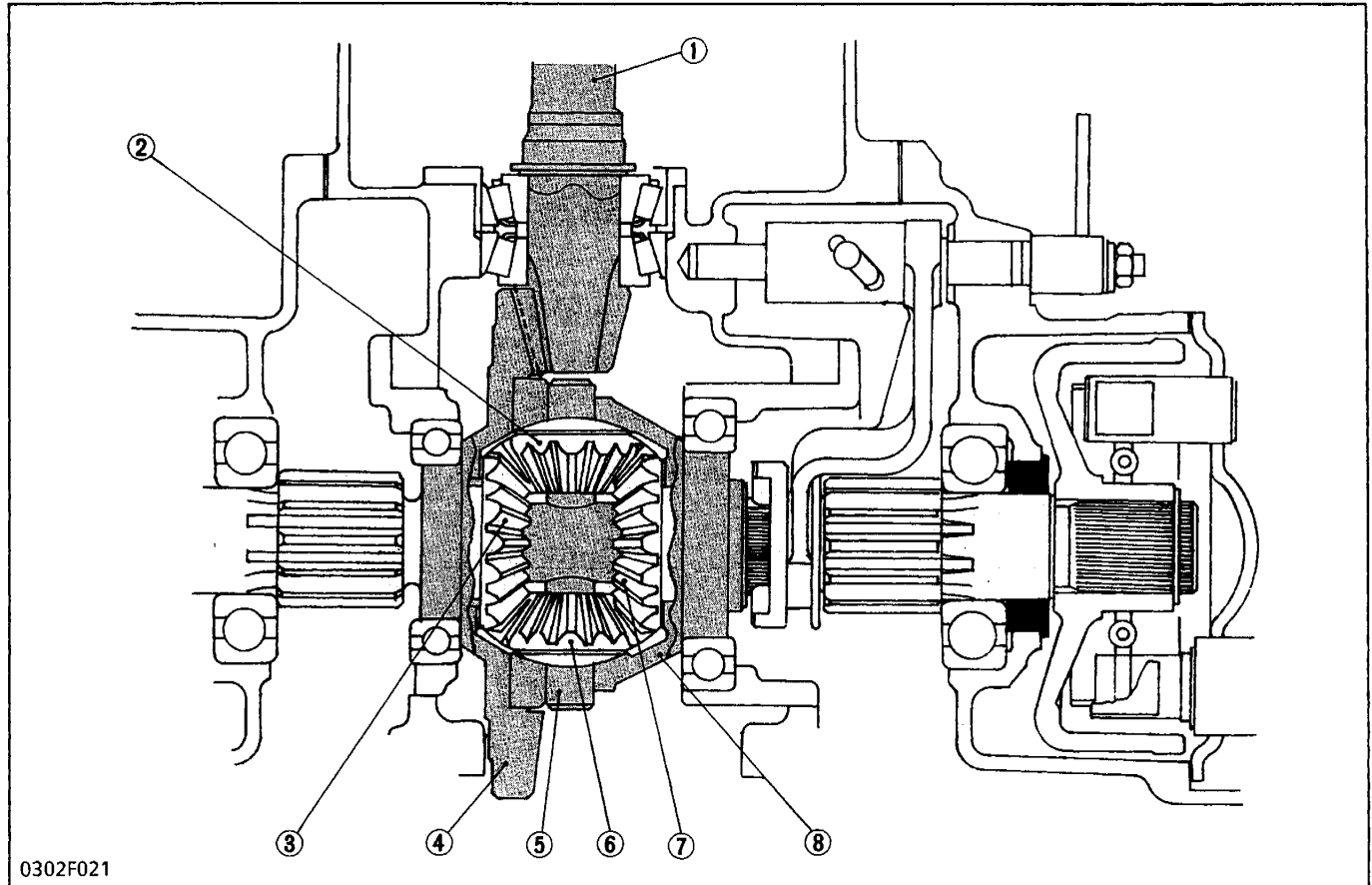

0302F021

- | | | | |
|-------------------------|----------------------------|-------------------------------|----------------------------|
| (1) Spiral Bevel Pinion | (3) Differential Side Gear | (5) Differential Pinion Shaft | (7) Differential Side Gear |
| (2) Differential Pinion | (4) Spiral Bevel Gear | (6) Differential Pinion | (8) Differential Case |

1. During Straight Running

Rotation of the spiral bevel pinion (1) is transmitted to the spiral bevel gear (4) and differential case (8).

When road resistance to the right and left wheels are equal, differential pinions (2), (6) and differential side gears (3), (7) are all rotate as a unit. Both rear axles received equal input, and both wheels turn at the same speed, allowing the tractor to go straight ahead.

At this time, differential pinions do not rotate around the differential pinion shaft (5).

2. During Turning

When the tractor turns, the road resistance to the inside tire increases (as if braking is applied to that side only). In other words, if one of tires slows down, revolution difference is generated in the differential side gears (3), (7). When rotation of one differential side gear becomes lower than the other, differential pinions (2), (6) begin rotating around differential pinion shaft (5). The other differential side gear is increased in speed by the speed increment of differential pinion rotating around differential pinion shaft. This means that rotation of one rear axle is slowed down and that of the other rear axle is increased. Thus, the tractor turn smoothly without power loss.

The combined number of revolutions of the right and left differential side gears is always twice that of the spiral bevel gear (4). When spiral bevel gear revolution is 100 rpm, and if one of the differential side gears stops moving, the revolution of the other differential side gear becomes 200 rpm and if one rotates at 50 rpm, the other rotates at 150 rpm.

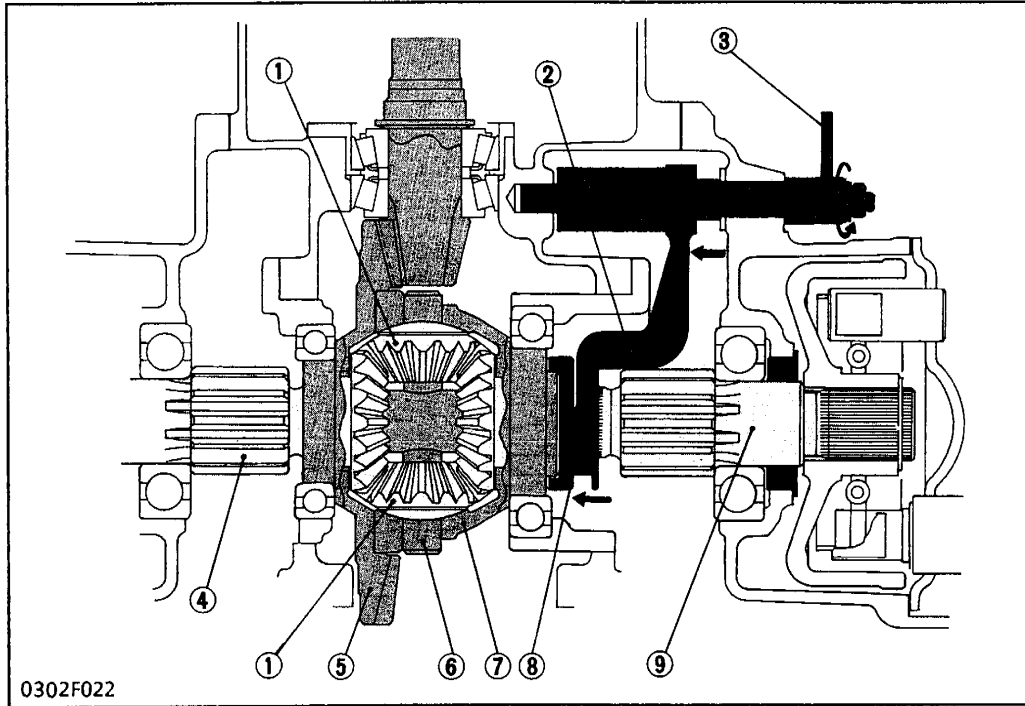
[2] DIFFERENTIAL LOCK

- (1) Differential Pinions
- (2) Shift Fork
- (3) Differential Lock Lever
- (4) Differential Gear Shaft
- (5) Spiral Bevel Gear
- (6) Differential Pinion Shaft
- (7) Differential Case
- (8) Differential Lock Clutch
- (9) Differential Gear Shaft

0302F022

When resistance to the right and left tires are greatly different due to ground conditions or type of work, the tire with less resistance slips and prevents the tractor from moving ahead. To compensate for this drawback, the differential lock restricts the differential action and causes both rear axles to rotate as a unit.

When the differential lock pedal is stepped on, it causes the differential lock lever (3) to rotate, which will move the shift fork (2) and the differential lock

clutch (8) toward the spiral bevel gear (5). The differential lock clutch (8) engaged with the teeth of the differential case (7) to cause the differential case (7) and the differential lock clutch (8) to rotate as a unit.

Therefore, differential pinions (1) are unable to rotate around differential pinion shaft (6) and identical revolutions are transmitted to the right and left differential gear shafts (4),(9).

5 BRAKE

■ B1550-B1750-B1550HST-B1750HST

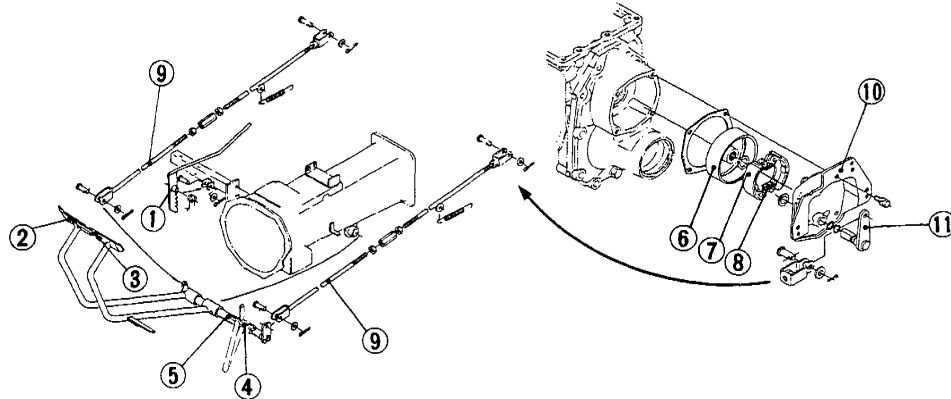

0354F010

■ B2150-B2150HST

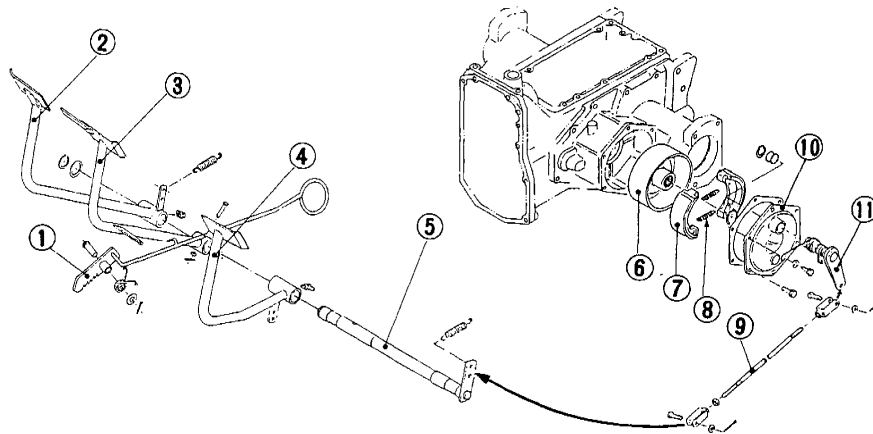

0354F011

- | | | | |
|--------------------|-----------------------|-------------------|------------------|
| (1) Lock Lever | (4) Clutch Pedal | (7) Brake Shoe | (10) Brake Cover |
| (2) Brake Pedal RH | (5) Brake Pedal Shaft | (8) Return Spring | (11) Brake Cam |
| (3) Brake Pedal LH | (6) Brake Drum | (9) Brake Rod | |

Each of rear wheels are equipped with separate brakes which can be applied independently or locked together for simultaneous application. The brakes are mechanical internal-expansion type with leading-trailing brake shoes (7).

They are connected to the two brake pedals (2), (3) which the operator controls with his right foot. The brakes can be operated in two ways. The first is independent operation of the right and left pedals to actuate the right and left brakes separately. This is

used for turning in a small radius. The other way is simultaneous use of the right and left pedals. The pedals are locked together so that when either the right or left pedal is pressed, both brakes are simultaneously actuated. This is used to stopping or reducing speed while traveling on road.

⚠ CAUTION

- While traveling on road, the two brake pedals must be locked together for safety.

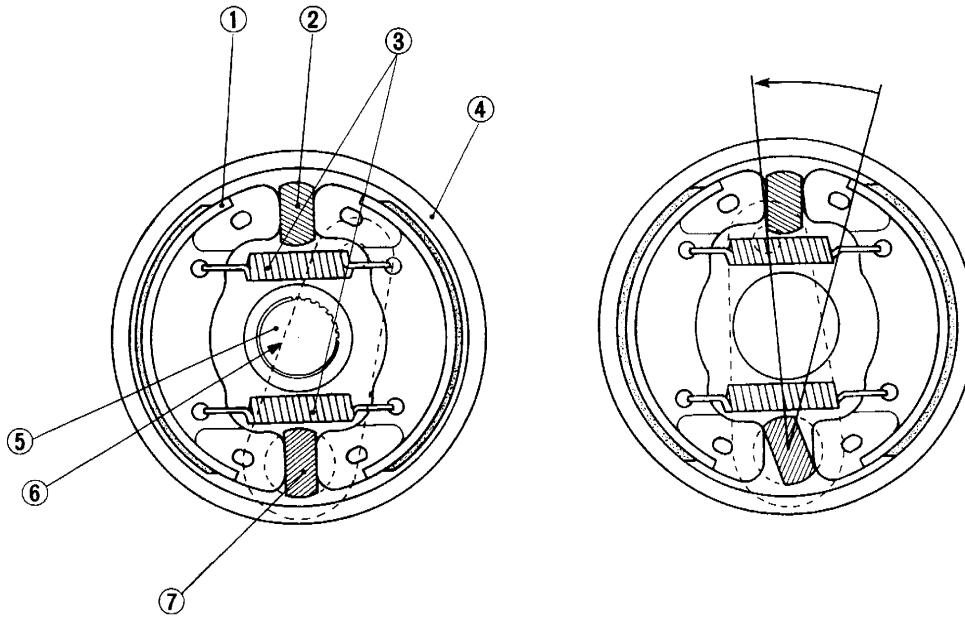

0302F024

- (1) Brake shoe
- (2) Anchor Cam
- (3) Return Spring
- (4) Brake Drum
- (5) Differential Gear Shaft
- (6) Brake Arm
- (7) Brake Cam

The brake drum (4) is splined to the differential gear shaft (5), which meshes with the final drive gear. Pressure against the foot pedals is transferred through the brake arm (6). Movement of the arm causes the brake cam (7) to rotate, expanding the brake shoes (1) outward against the brake drum (4).

The same amount of braking force is produced in both forward and reverse motion.

As the brake shoes (1) are pressed against the drum (4), the rotation of the differential gear shaft (5) is retarded, which in turn stops, or slows final drive gear rotation.

6 FRONT AXLE

The front axle supports the front of tractor and facilitates steering. There are two kinds of front axles. The two-wheel drive axle has free-running front wheels and the four-wheel drive axle has powered front wheels.

[1] FRONT WHEEL ALIGNMENT

Front wheel alignment is a term given to mean four angle settings in three dimensions camber, kingpin inclination, toe-in and caster angle. These angle settings are made for the following purposes.

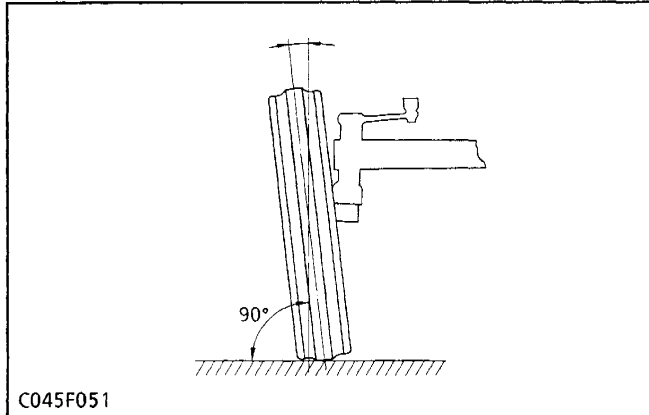

1) Camber

The front wheels are tilted from the vertical as viewed from the front, the wheels are farther apart at the top than at the bottom. This inclination is called camber. Camber reduces rolling resistance of the wheels, and also minimizes bending or twisting of the front axle.

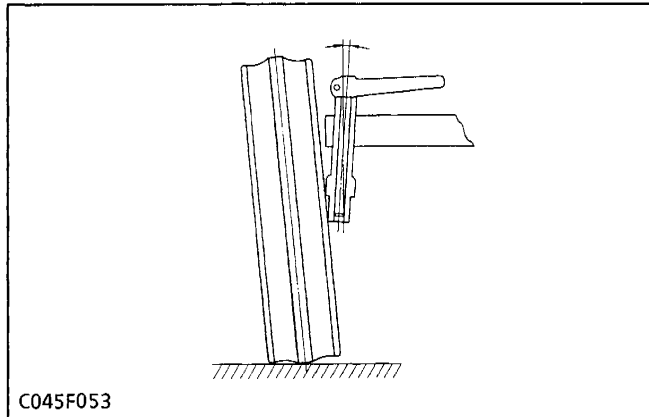

2) Kingpin Inclination

The kingpin is tilted from the vertical as viewed from the front. This inclination is called kingpin inclination. As with the camber, kingpin inclination reduces rolling resistance of the wheels, and prevents any shimmy motion of the steering wheel. It also reduces steering effort.

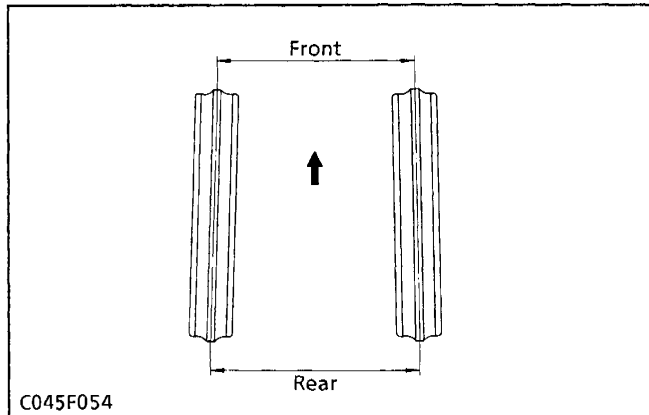

3) Toe-in

Viewing the front wheels from above reveals that the distance between the front wheels is less at the front than at the rear. This turning in of the front wheels is called toe-in. The front wheels tend to roll outward due to the camber, but toe-in offsets this and ensures parallel rolling of the front wheel. Another purpose of toe-in is to prevent excessive and uneven wear of tires.

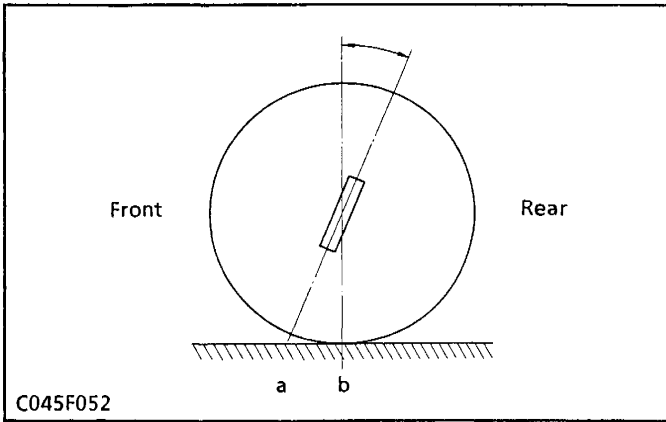

4) Caster

The kingpin is tilted forward as viewed from the side. That is, the intersection (a) made by the center line of the kingpin shaft and the ground is ahead of the intersection (b) made by the center line of the wheel and ground. This inclination is called caster. Caster helps provide steering stability. As with the kingpin inclination, caster reduces steering effort.

[2] STRUCTURE

(1) Two Wheel Drive Type

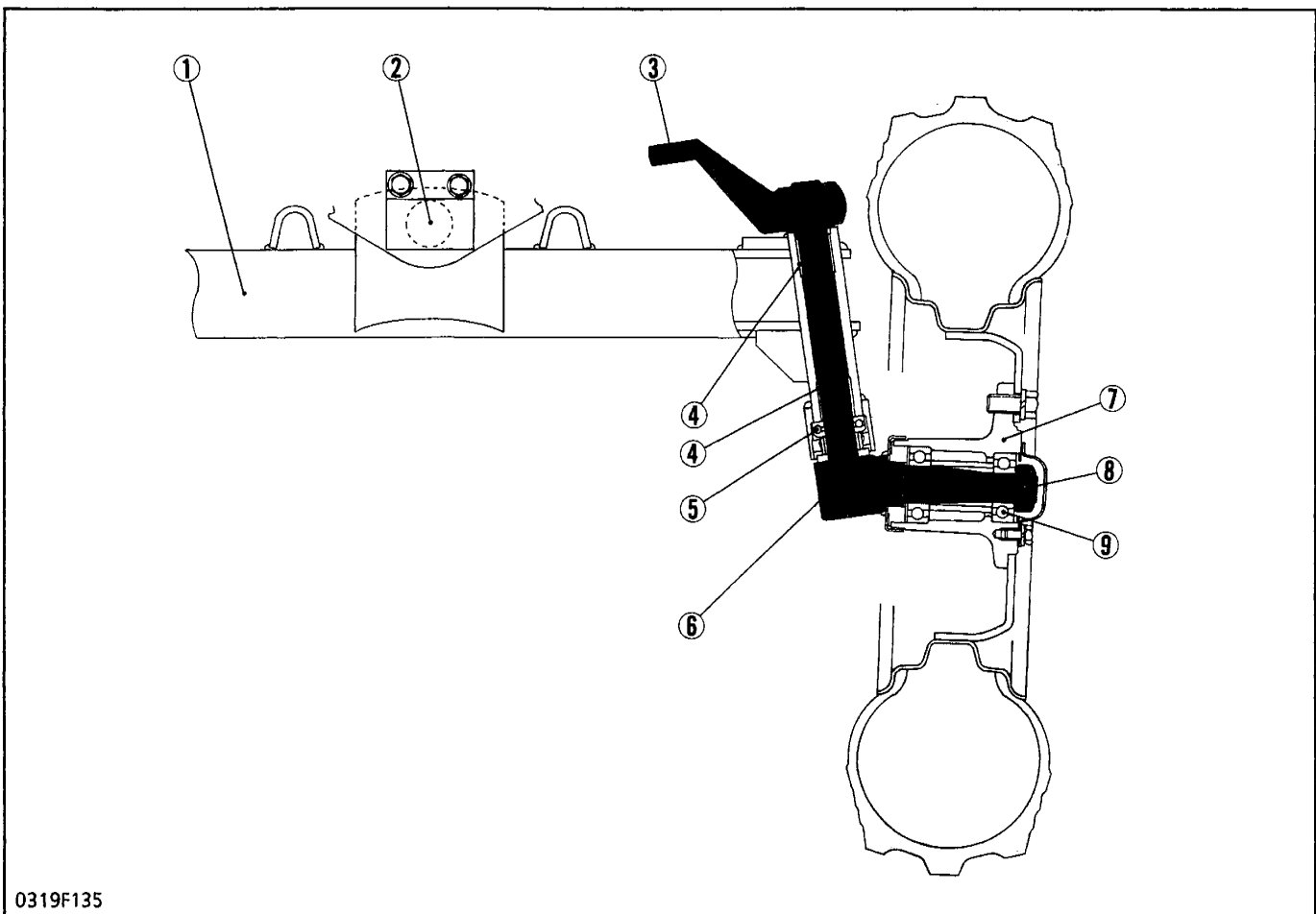

- (1) Front Axle
- (2) Center Pin
- (3) Knuckle Arm

- (4) Bushing
- (5) Thrust Ball Bearing

- (6) Knuckle Shaft
- (7) Front Wheel Hub

- (8) Slotted Nut
- (9) Ball Bearing

The front axle of the 2WD type is constructed as shown above.

The knuckle shaft (6) is attached to the front axle (1) by the "RUMOAN" method.

With this method, the shape of the front axle is

relatively simple, and the front axle is supported at its center with center pin (2), so that steering operation is stable even on an uneven ground encountered in a farm fields.

(2) Four Wheel Drive Type

■ B1550-B1550HST

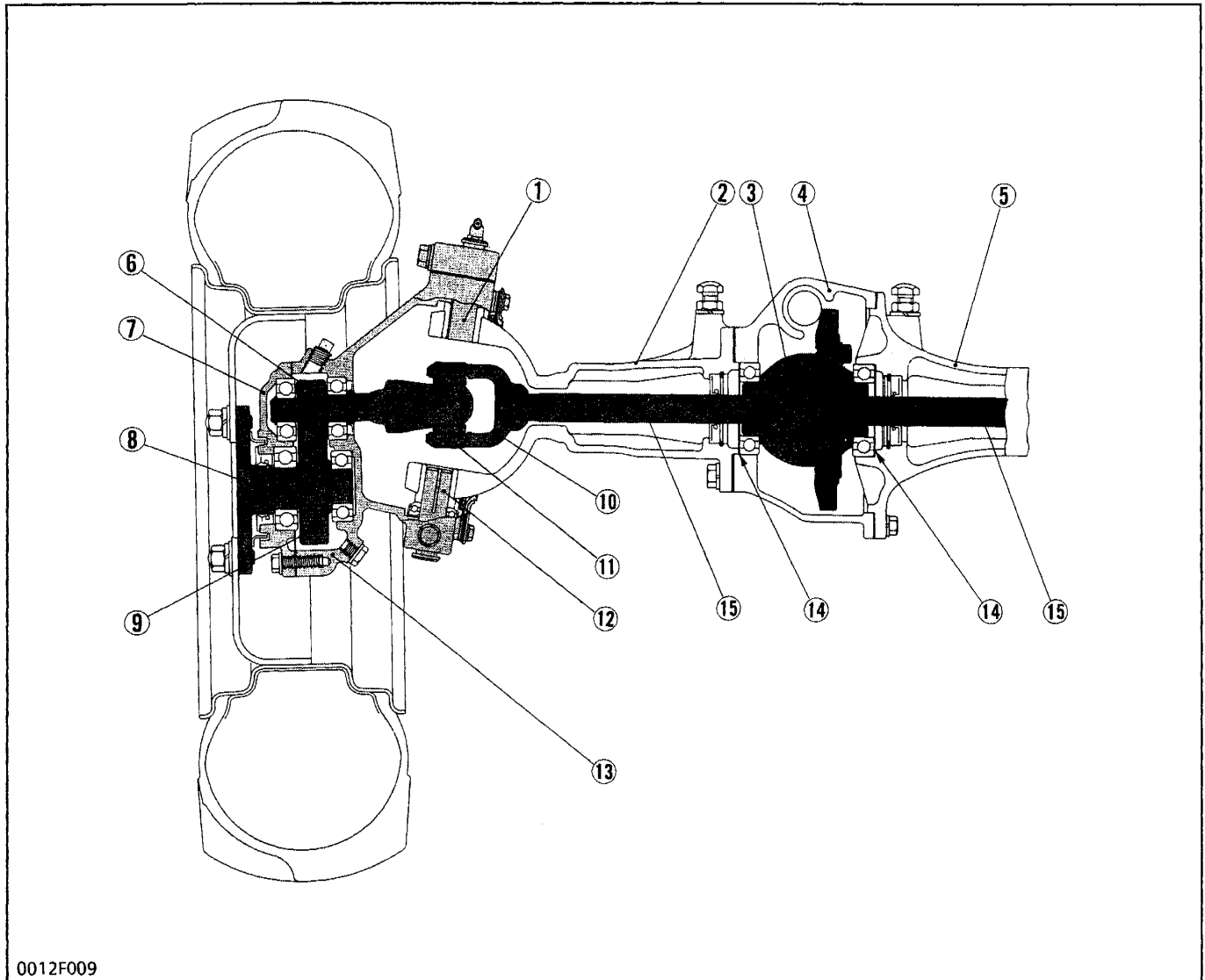

- | | | | |
|-----------------------|-----------------------|------------------|----------------|
| (1) Kingpin 1 | (5) Front Axle Case 2 | (9) 25T Gear | (13) Gear Case |
| (2) Front Axle Case 3 | (6) 12T Gear | (10) Joint | (14) Shim 1,2 |
| (3) Differential | (7) Gear Case Cover | (11) Joint Shaft | (15) Shaft |
| (4) Front Axle Case 1 | (8) Front Wheel Hub | (12) Kingpin 2 | |

The front axle of the B1550 and B1550HST is constructed as shown above.

Power is transmitted from the transmission to right and left shafts (15) through the drive shaft, spiral bevel pinion shaft and differential (3).

Universal joint (10) transmits the power from each shaft to the gear in the gear case (13), which pivots around the kingpins.

The gear (6) in the gear case is splined to joint shaft (11) and meshes with gear (9).

■ B1750-B2150-B1750HST-B2150HST

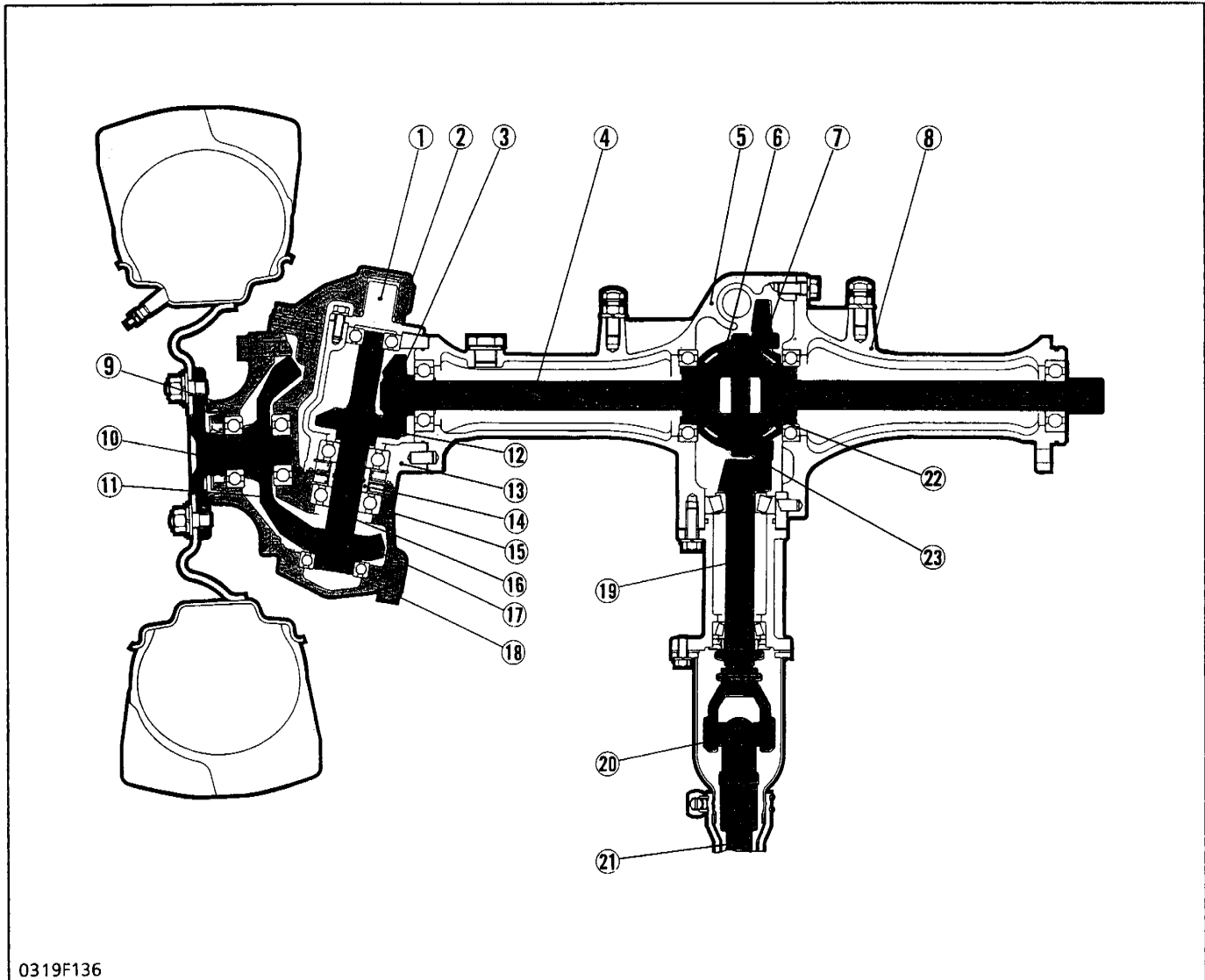

0319F136

- | | | | |
|-----------------------------|-------------------------|--------------------------|--------------------------------|
| (1) Knuckle Arm Support | (7) Differential Pinion | (13) Bevel Gear Case | (19) Spiral Bevel Pinion Shaft |
| (2) Knuckle Arm | (8) Front Axle Arm LH | (14) Seal Collar | (20) Universal Joint Front |
| (3) Bevel Gear | (9) Front Axle Cover | (15) Front Axle Case | (21) Drive Shaft |
| (4) Differential Gear Shaft | (10) Front Wheel Hub | (16) Bevel Gear Shaft | (22) Differential Side Gear |
| (5) Front Axle Arm RH | (11) Bevel Gear | (17) Bevel Gear | (23) Ring Gear |
| (6) Differential Pinion | (12) Bevel Gear | (18) Bevel Support Cover | |

The front axle of the B1750, B2150, B1750HST, and B2150HST is constructed as shown above.

Power is transmitted from the transmission through the drive shaft (21) to the spiral bevel pinion shaft (19), and to the differential, and through the differential gear shaft (4) in the front axle arm (5) to

the bevel gear shaft (16) in the bevel gear case (13).

Finally the powers, is transmitted to the front wheel hub (10).

The differential system allows each wheel to rotate at a different speed to make turning easier.

■ Bi-speed Turn (B1550-B1750-B1550HST-B1750HST)

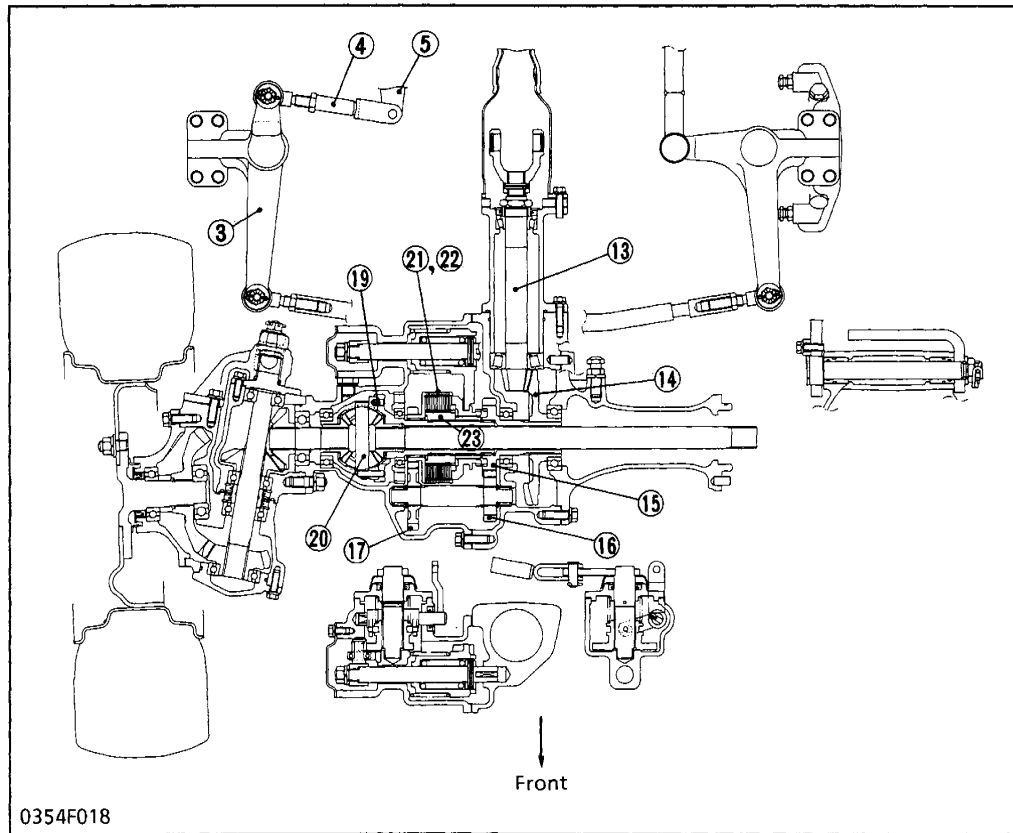

- (1) Bi-speed Turn Shift Lever
- (2) Bi-speed Turn Shift Rod
- (3) Knuckle Arm
- (4) Shift Link
- (5) Shift Lever
- (6) Shift Lever Fulcrum
- (7) Change Lever
- (8) Shift Roller Shaft
- (9) Front Axle Case (Bi-speed Turn)
- (10) Spring
- (11) Bi-speed Turn Shift Fork
- (12) Shifter
- (13) Front Pinion
- (14) Spiral Bevel Gear
- (15) 22T Gear Shaft
- (16) 15T Gear
- (17) 20T Gear
- (18) 17T Clutch Gear
- (19) Front Differential Shaft
- (20) Front Differential Assembly
- (21) Friction Plate
- (22) Clutch Disc
- (23) Clutch Boss

0354F018

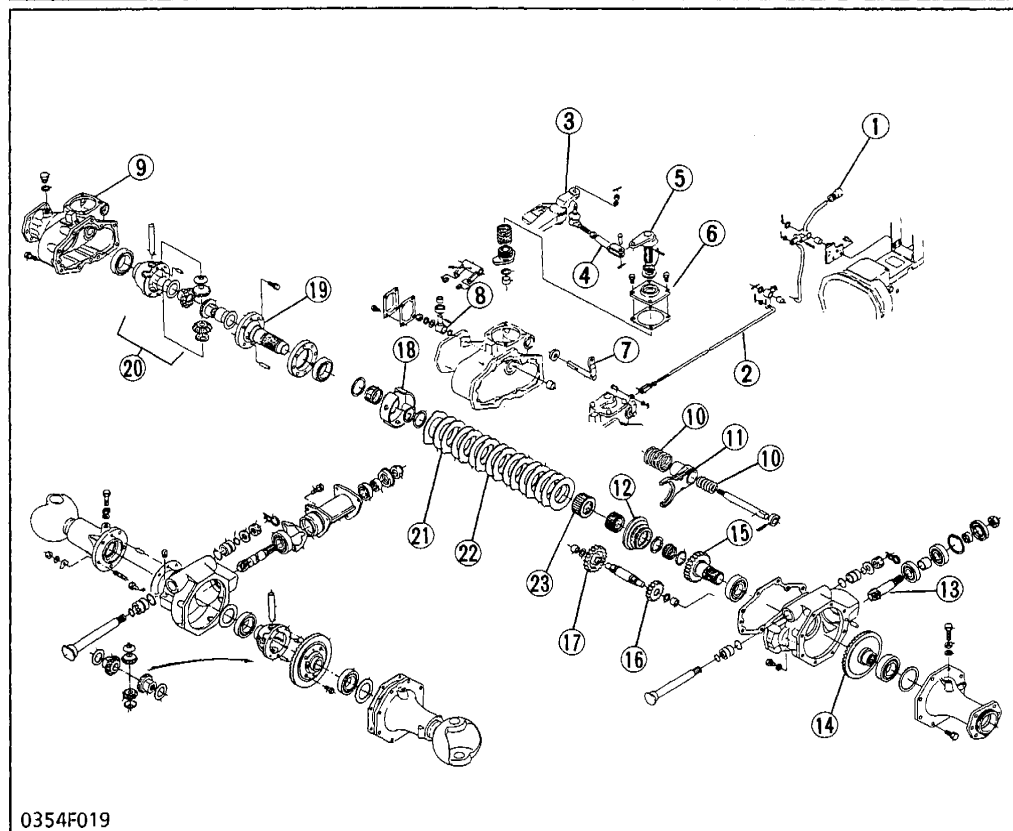

0354F019

The front axle with bi-speed turn of the B1550, B1750, B1550HST and B1750HST is constructed as shown above. Front wheel speed change mechanism, which is located in the front axle case

assembly (9) consists of the bi-speed turn clutch assembly, shifter, two sets of gears ((15)(16), (17)(18)) and bi-speed turn linkage.

■ Bi-speed Clutch and Gears

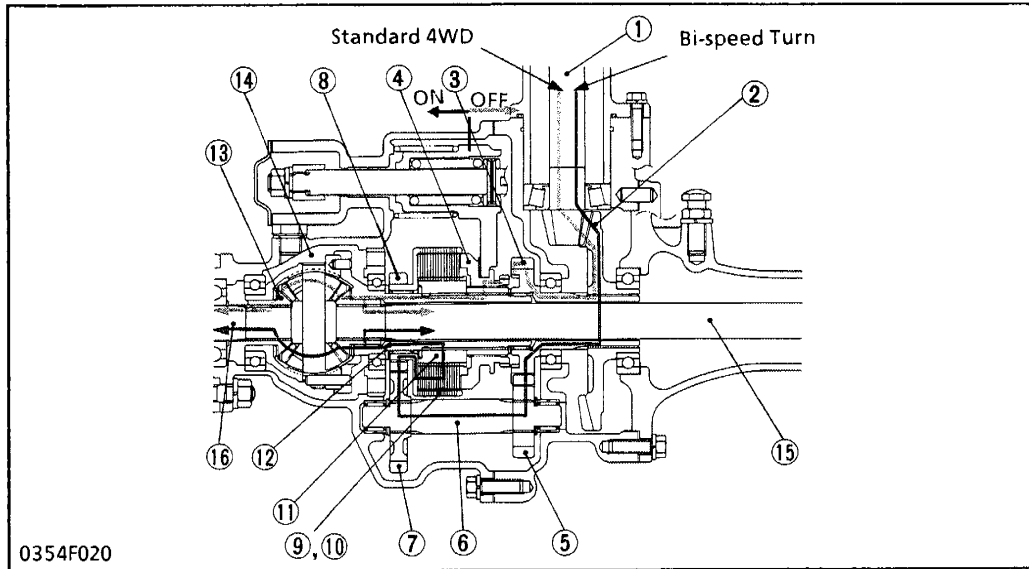

- (1) Pinion Shaft
- (2) Spiral Bevel Gear
- (3) 22T Gear Shaft
- (4) Shifter
- (5) 15T Gear
- (6) Bi-speed Turn Shaft
- (7) 20T Gear
- (8) 17T Clutch Gear
- (9) Clutch Plate
- (10) Clutch Disc
- (11) Clutch Boss
- (12) Front Diff. Shaft
- (13) Diff. Side Gear
- (14) Diff. Gear Assembly
- (15) Shaft, Left
- (16) Shaft, Right

Bi-speed clutch is mechanically engaged when front wheel reaches approximately 40 degree turning angle.

This bi-speed turn front wheel speed is 1.7 times higher than the standard front wheel speed.

■ Standard 4WD (Shift fork is moved right)

22T Gear Shaft (3)→Shifter (4)→Front Diff. Shaft (12)→Diff. Side Gear (13)→Shaft, R (16)
 →Diff. Gear Assembly (14)→Shaft, L (15)

■ Bi-speed Turn 4WD (Shift fork is moved left)

22T Gear Shaft (3)→15T Gear (5)→Bi-speed Shaft (6)→20T Gear (7)→17T Clutch Gear (8)→Clutch Plate (9)→Clutch Disc (10)→Clutch Boss (11)→Front Diff. Shaft (12)→Diff. Side Gear (13)→Shaft, R (16)
 →Diff. Gear Assembly (14)→Shaft, L (15)

■ Bi-speed Cam

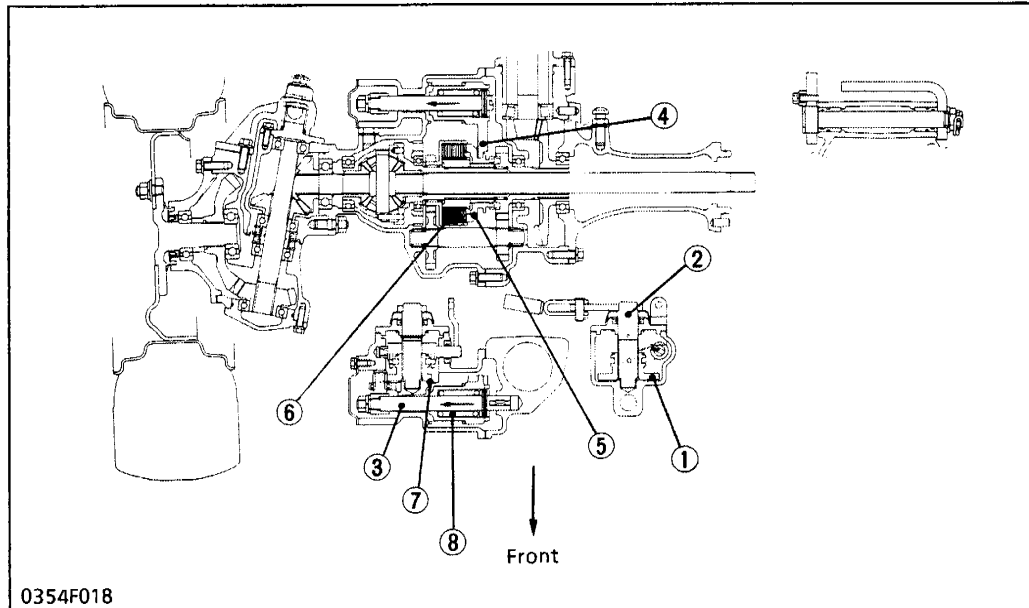

- (1) Shift Cam
- (2) Shift Lever
- (3) Shift Rod
- (4) Shift Fork
- (5) Shifter
- (6) Bi-speed Turn Clutch
- (7) Spring
- (8) Spring

Bi-speed turn 4WD and standard 4WD positions are selected by change lever to move the position of shift cam (1).

■ Standard 4WD Position

The shift cam (1) is free to turn, so that the shift rod (3) and shift fork (4) are remained in standard 4WD position by springs (7), (8).

■ Bi-speed Turn 4WD Position

When the steering wheel is turned more than approx. 40 degree turning angle, the shift lever (2) and shift cam (1) are turned together. This cam make the shift rod (3) move left (arrow direction) so that the shifter (5) is engaged with the bi-speed turn clutch (6).

7 STEERING

[1] MANUAL STEERING

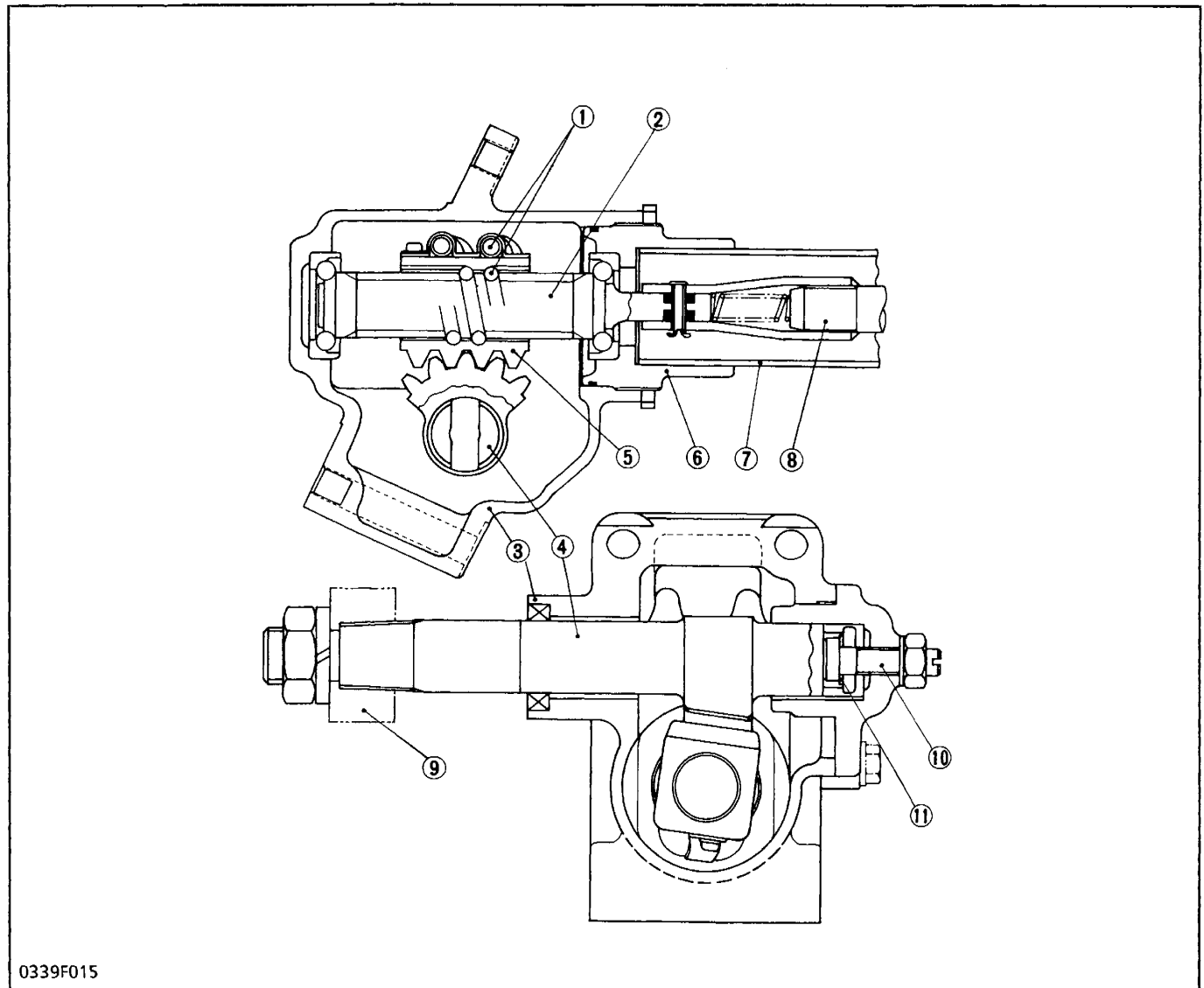

0339F015

- | | | | |
|----------------|-----------------------|---------------------|----------------------|
| (1) Balls | (4) Sector Gear Shaft | (7) Steering Column | (10) Adjusting Screw |
| (2) Worm Shaft | (5) Ball Nut | (8) Steering Shaft | (11) Shim |
| (3) Gear Box | (6) Gear Box Cover | (9) Pitman Arm | |

The steering unit mainly consists of two parts, a ball nut (5) and a sector gear shaft (4). When the worm shaft (2) is rotated (by rotation of the steering wheel), the ball nut (5) is moved along the worm shaft (2), and this action causes the sector gear shaft (4) to rotate. The one end of the sector gear shaft (4) carries the pitman arm (9). Rotation of the sector gear shaft (4) causes the pitman arm (9) to swing in one direction or the other. The motion is then

carried through the drag link to the knuckle arm at the wheel.

In this unit, friction is kept exceptionally low by interposing balls (1) between the worm teeth and groove cut in the inner face of a ball nut (5).

Steering wheel play can be adjusted by turning an adjusting screw (10) at the end of the sector gear shaft, and with shims (11).

[2] POWER STEERING

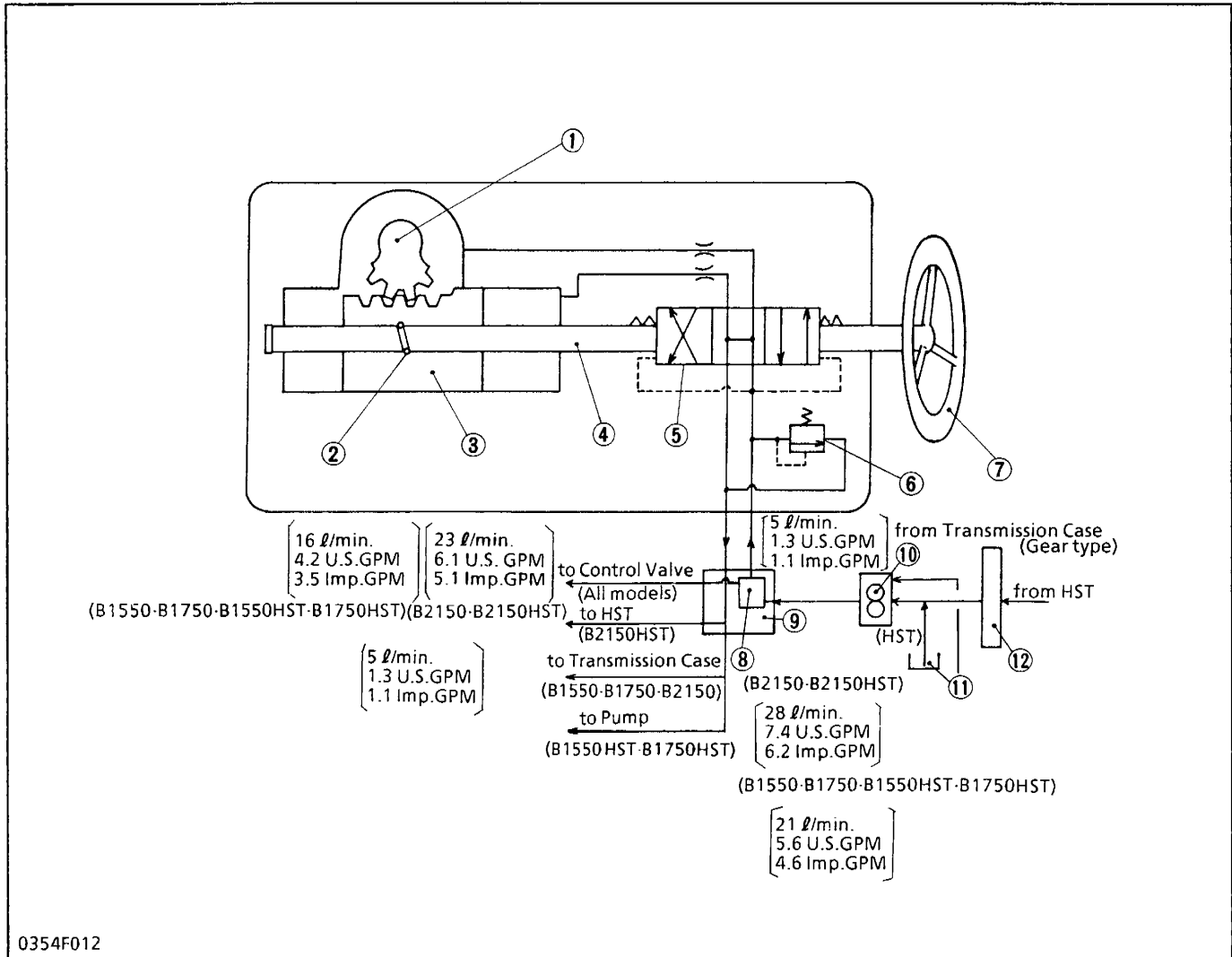

0354F012

- | | | | |
|-----------------------|-------------------|---------------------------------|------------------------|
| (1) Sector Gear Shaft | (4) Worm Shaft | (7) Steering Wheel | (10) Pump |
| (2) Balls | (5) Sliding Valve | (8) Flow Priority Valve | (11) Transmission Case |
| (3) Ball Nut | (6) Relief Valve | (9) Hydraulic Block Type Outlet | (12) Cooler |

All models are available to be equipped with integral type power steering that of sliding valve with centering spring type.

Flow priority valve (8) divides the oil fed to hydraulic block type outlet (9) into two directions. One is the control flow to power steering (constantly 5 l/min., 1.3 U.S.GPM, 1.1 Imp.GPM at any engine speed). And the other is excessive flow to control valve.

The mechanical gear section shown in the next page operates in the same way as ordinary manual steering systems. However, with power steering, the worm shaft (4) is supported only by the centering springs (14).

When the worm thrust force (turning force of the ball screw section) exceeds centering spring setting load, the worm shaft (4) axially shifts by a specified displacement (Stroke: about 0.4 mm (0.016 in.)). When a load is applied to tires and worm thrust force required for operation is greater than the centering spring setting load, turning the steering wheel does not rotate the sector gear shaft (1), but rather axially moves the worm shaft (4). The valve spool (21), fixed on the worm shaft (4) by the nut (23), changes the condition of the three-position, four-way open center (all ports open) valve (5) by sliding in the valve housing (22), to generate pressure as required.

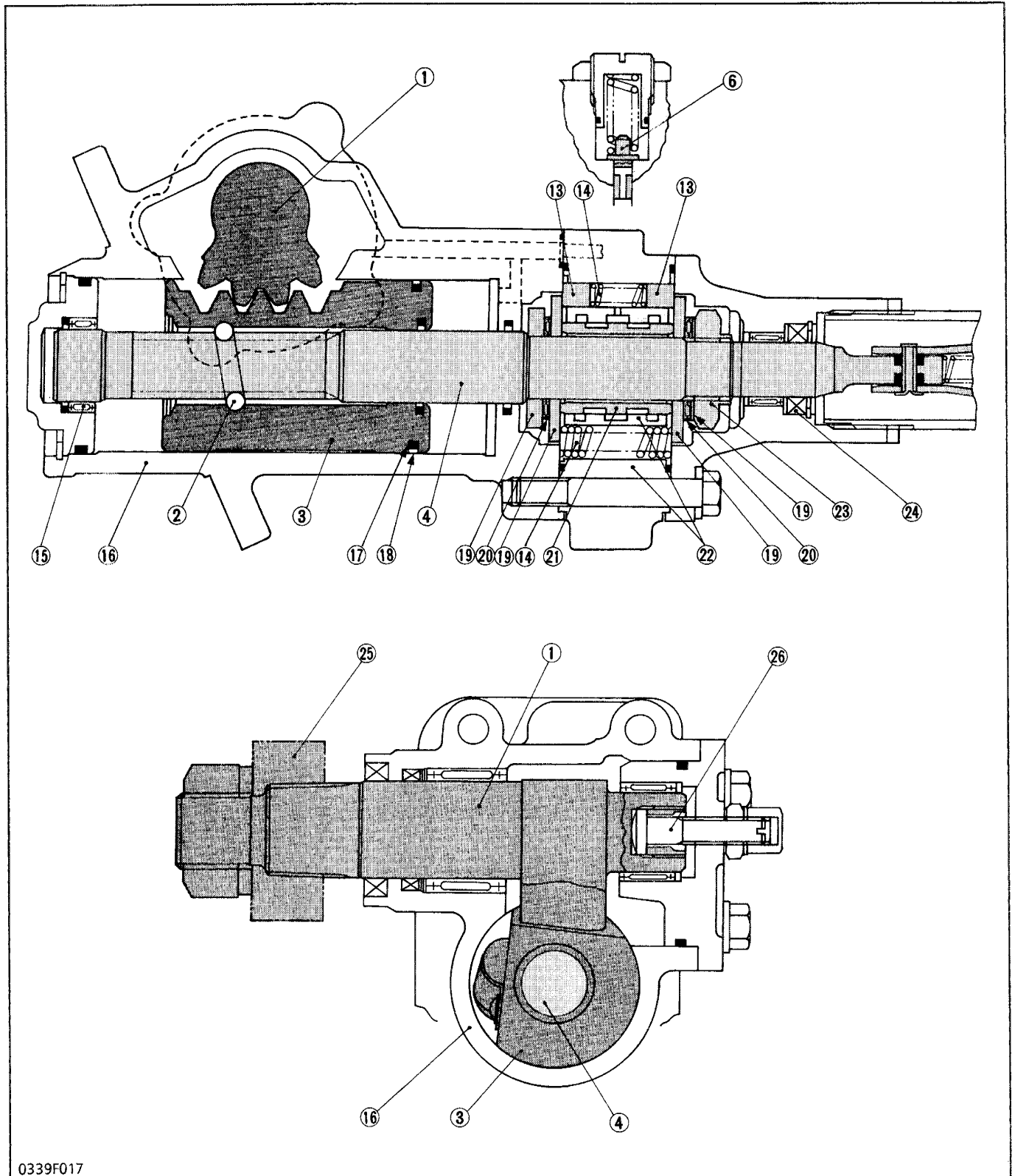

0339F017

- | | | | |
|-----------------------|------------------------|-----------------------------|-------------------------------|
| (1) Sector Gear Shaft | (13) Reaction Pistons | (18) Teflon Ring | (23) Nut |
| (2) Ball | (14) Centering Springs | (19) Thrust Races | (24) Oil Seal |
| (3) Ball Nut | (15) Needle Bearing | (20) Thrust Needle Bearings | (25) Pitman Arm |
| (4) Worm Shaft | (16) Gear Case | (21) Spool | (26) Adjusting Screw for Play |
| (6) Relief Valve | (17) O-Ring | (22) Valve Housing | |

■ Neutral Position

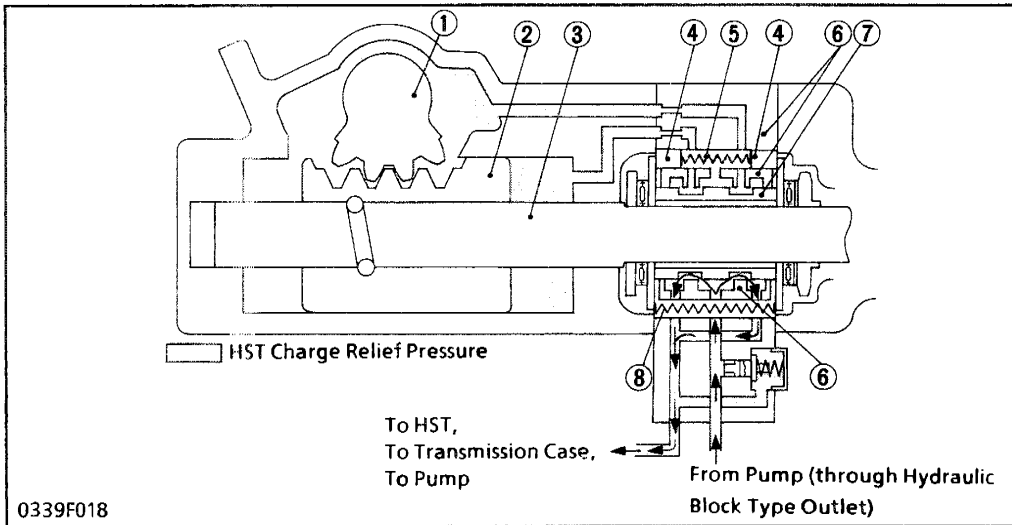

- (1) Sector Gear Shaft
- (2) Ball Nut
- (3) Worm Shaft
- (4) Reaction Pistons
- (5) Centering Spring
- (6) Valve Housing
- (7) Spool
- (8) Centering Spring

0339F018

When the steering wheel is not turned, the valve is placed in the neutral position by the centering springs (5) (8) and pressurized reaction pistons (4), and the pressure-fed oil from pump through the flow priority valve flows to the hydrostatic transmission (HST).

Therefore, there is no difference between pressures on the right and left cylinder chambers. And the ball nut (2) and sector gear shaft (1) do not move. So, the front wheels keep the direction.

■ Left Turning

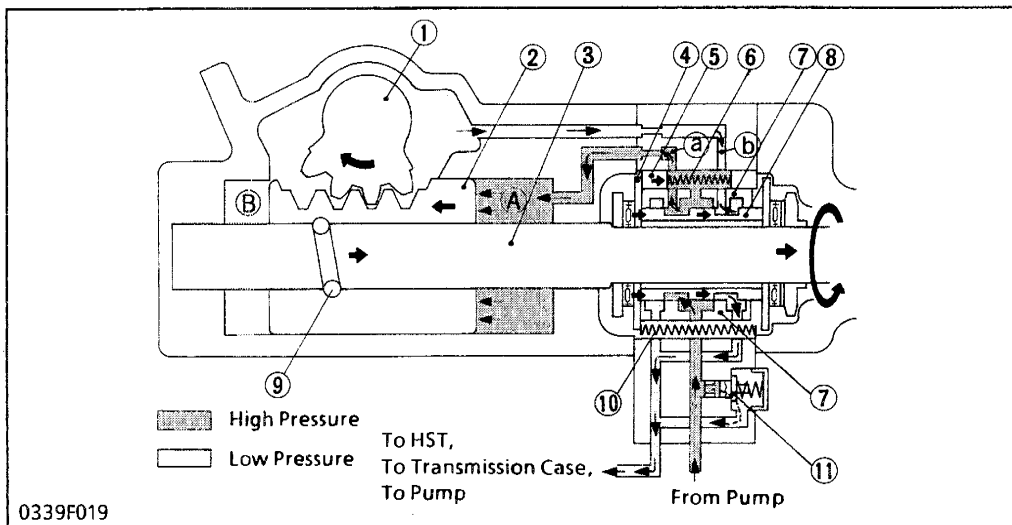

- (1) Sector Gear Shaft
 - (2) Ball Nut
 - (3) Worm Shaft
 - (4) Thrust Race
 - (5) Reaction Piston
 - (6) Centering Spring
 - (7) Valve Housing
 - (8) Spool
 - (9) Ball
 - (10) Centering Spring
 - (11) Relief Valve
- (A) Chamber "A"
 (B) Chamber "B"
 (a) Port "a"
 (b) Port "b"

0339F019

1. When the steering wheel is turned counterclockwise, the worm shaft (3) is also turned. However, front wheel load stops sectors gear shaft (1) and ball nut (piston) (2) from moving, and only worm shaft (3) turns counterclockwise. Then, due to the reaction, the worm shaft (3) moves upward a little. And the thrust race (4) pushes the spool (8), reaction piston (5) and centering springs (6) (10).

2. At this time, the oil passage from pump to port "b" and oil passage from port "a" to HST are closed. Therefore, the pressure-fed oil from pump flows to the chamber "A" through port "a". Thus, the ball nut (piston) (2) is pushed, and the sector gear shaft (1) is rotated in the direction of the arrow. Oil in chamber "B" flows to the HST through port "b"

■ Right Turning

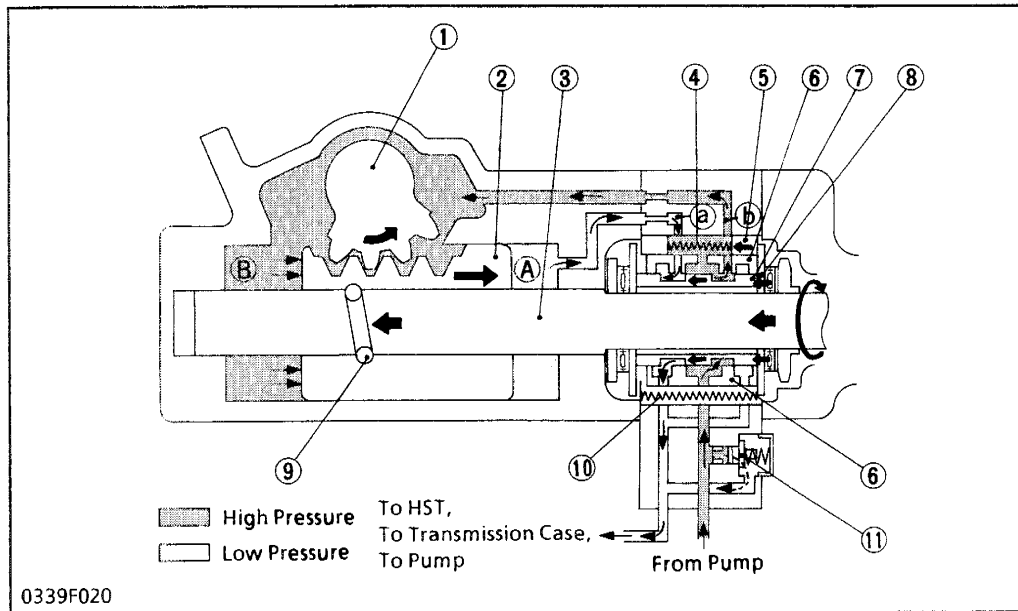

- (1) Sector Gear Shaft
- (2) Ball Nut
- (3) Worm Shaft
- (4) Centering Spring
- (5) Reaction Piston
- (6) Valve Housing
- (7) Spool
- (8) Thrust Race
- (9) Ball
- (10) Centering Spring
- (11) Relief Valve

- (A) Chamber "A"
- (B) Chamber "B"
- (a) Port "a"
- (b) Port "b"

1. When the steering wheel is turned clockwise, the worm shaft (3) is also turned. However, front wheel load stops sector gear shaft (1) and ball nut (2) from moving, and only worm shaft (3) turns clockwise. Then due to the reaction, the worm shaft (3) moves downward a little. And the thrust race (8) pushes the spool (7), reaction piston (5) and centering springs (4) (10).

2. At this time, the oil passage from pump to port "a" and oil passage from port "b" to HST are closed. Therefore, the pressure-fed oil from pump flows to the chamber "B" through port "b". Thus, the ball nut (piston) (2) is pushed, and the sector gear shaft (1) is rotated in the direction of the arrow. Oil in chamber "A" flows to the HST through the port "a"

■ Manual Operation
(When Engine Stops or Hydraulic Circuit Troubles)

Even when the engine stops or hydraulic circuit malfunctions thus leading to hydraulic operation stop, manual operation is possible. However, naturally, steering wheel requires a larger operating power.

If the steering wheel is turned when hydraulic

circuit ceases to operate, the worm shaft (3) moves slightly by the stroke of spool (7), then the worm shaft (3) and ball nut (2) have the same relationship with the manual steering gear. However, the steering wheel play increases by the stroke of spool (7).

■ Operation of Relief Valve

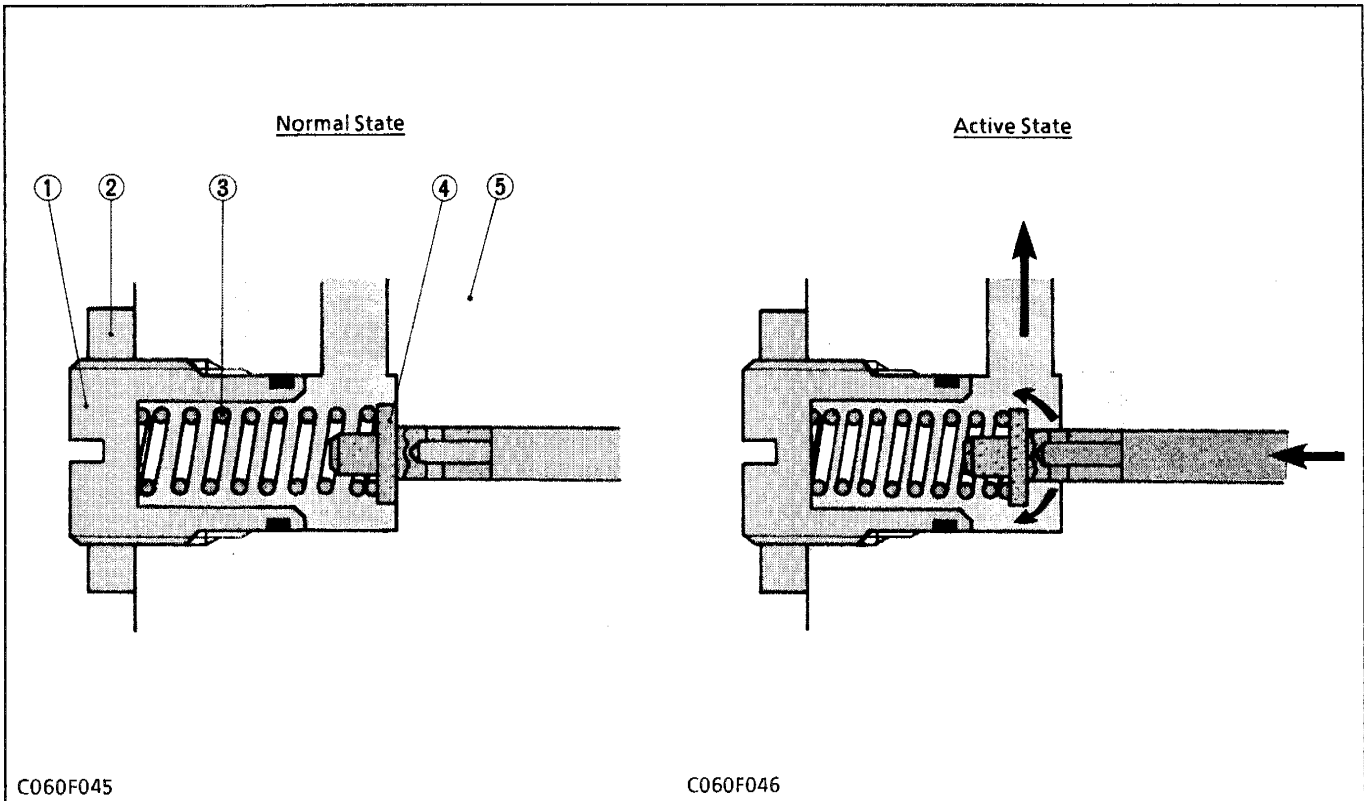

(1) Adjusting Screw
(2) Lock Nut

(3) Spring

(4) Poppet

(5) Valve Housing

This power steering is equipped with a direct-acting relief valve to restrict the maximum pressure in the hydraulic circuit and to prevent breakage of the hydraulic equipment.

When the pressure in the hydraulic circuit exceeds the relief valve setting pressure in such a case that the maximum steering angle of the front wheels is

reached or road resistance to the front tires is too great, the spring (3) is compressed to generate a gap between the poppet (4) and the valve housing (5). The pressure-fed oil flows to tank port through the gap so that pressure rise is restricted.

The relief valve setting pressure can be adjusted by turning the adjusting screw (1).

8 HYDRAULIC SYSTEM

■ B1550-B1750

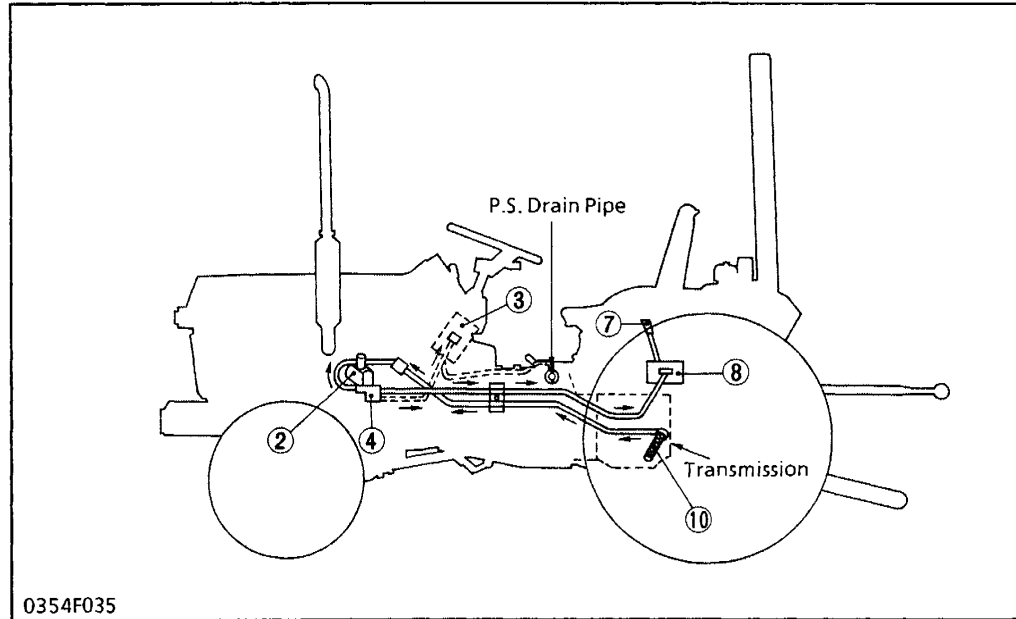

- (2) Hydraulic Pump
- (3) Power Steering (Optional)
- (4) Hydraulic Block Type Outlet
- (7) Position Control Lever
- (8) Control Valve
- (9) Hydraulic Cylinder
- (10) Oil Strainer
- (14) Check Valve 1
- (15) Check Valve 2
- (16) Main Control Valve
- (17) Unload Valve 2 (for shockless)
- (18) Feedback Rod
- (19) Unload Valve 1 (for unloading)
- (20) Relief Valve
- (21) Lowering Speed Control Valve
- (22) Relief Valve
- (23) Relief Valve
- (24) Flow Priority Valve
- (25) Directional Valve

0354F035

■ Hydraulic Circuit

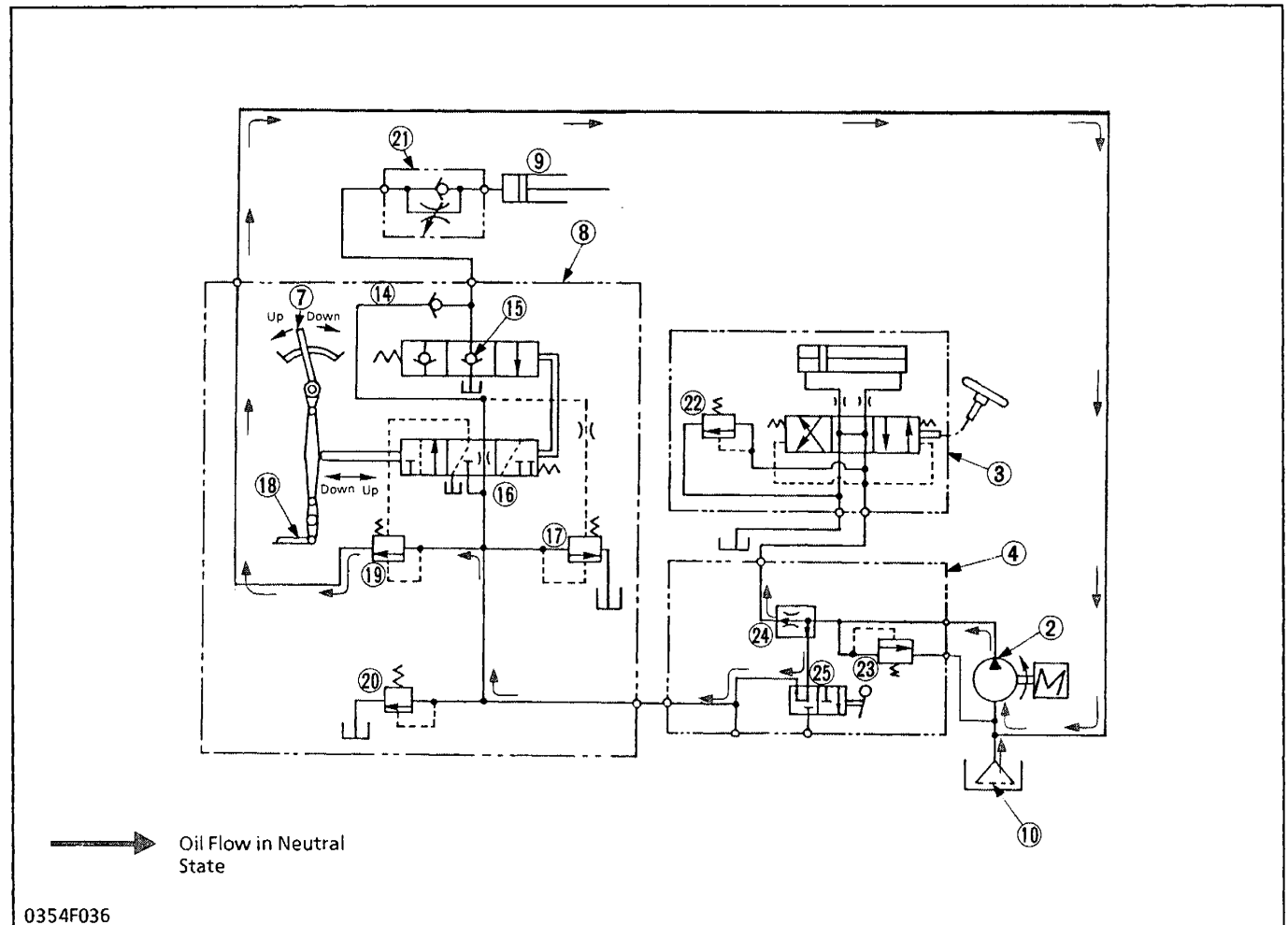

0354F036

■ B1550HST-B1750HST

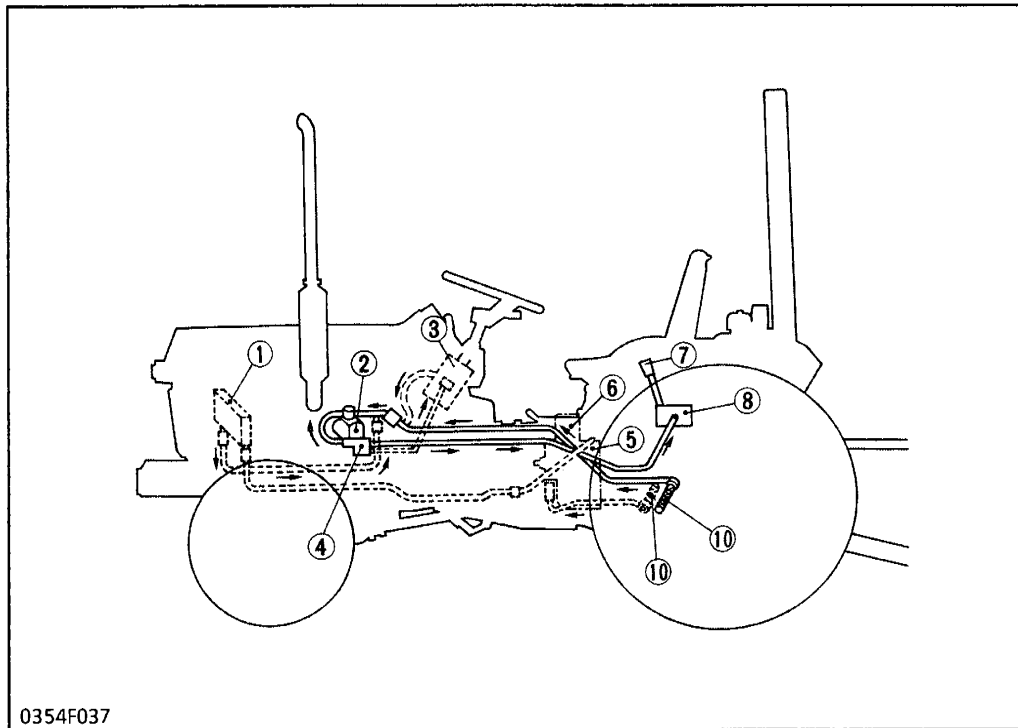

- (1) Cooler
- (2) Hydraulic Pump
- (3) Power Steering (Optional)
- (4) Hydraulic Block Type Outlet
- (5) Hydrostatic Transmission (HST)
- (6) Oil Filter (10 μm, 400 μin.)
- (7) Position Control Lever
- (8) Control Valve
- (9) Hydraulic Cylinder
- (10) Oil Strainer
- (14) Check Valve 1
- (15) Check Valve 2
- (16) Main Control Valve
- (17) Unload Valve 2 (for shockless)
- (18) Feedback Rod
- (19) Unload Valve 1 (for unloading)
- (20) Relief Valve
- (21) Lowering Speed Control Valve
- (22) Relief Valve
- (23) Relief Valve
- (24) Flow Priority Valve
- (25) Directional Valve

0354F037

■ Hydraulic Circuit

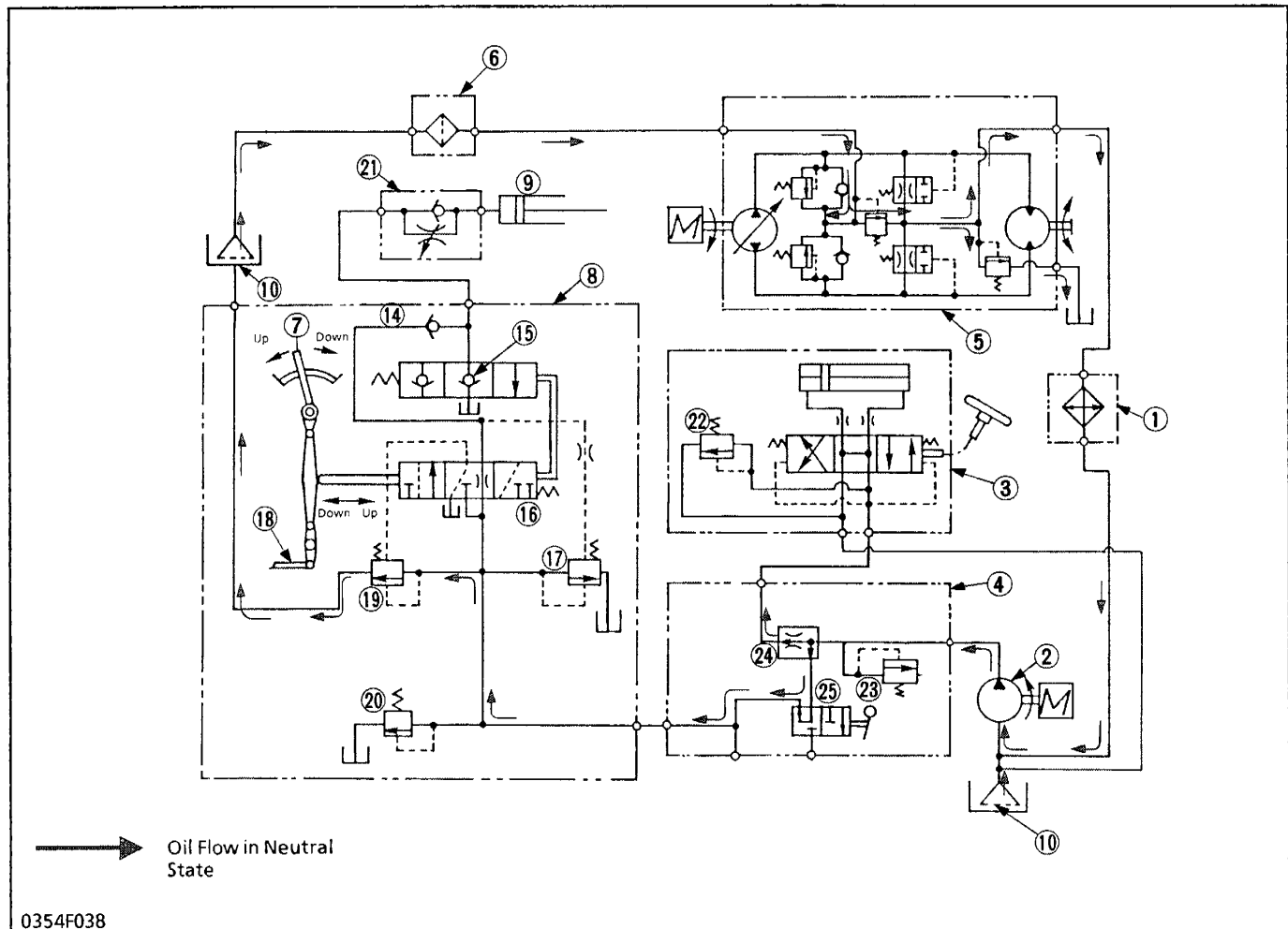

0354F038

■ B2150

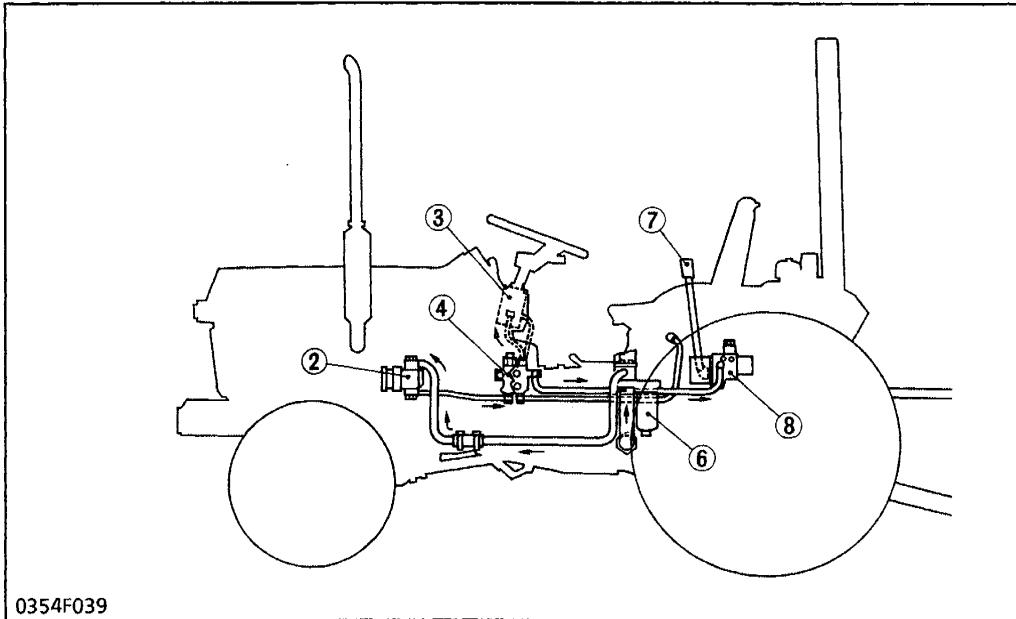

- (2) Hydraulic Pump
- (3) Power Steering (Optional)
- (4) Hydraulic Block Type Outlet
- (6) Oil Filter
- (7) Position Control Lever
- (8) Control Valve
- (9) Hydraulic Cylinder
- (14) Check Valve 1
- (15) Check Valve 2
- (16) Main Control Valve
- (17) Unload Valve 2 (for shockless)
- (18) Feedback Rod
- (19) Unload Valve 1 (for unloading)
- (20) Relief Valve
- (21) Lowering Speed Control Valve
- (22) Relief Valve
- (23) Relief Valve
- (24) Flow Priority Valve
- (25) Directional Valve

0354F039

■ Hydraulic Circuit

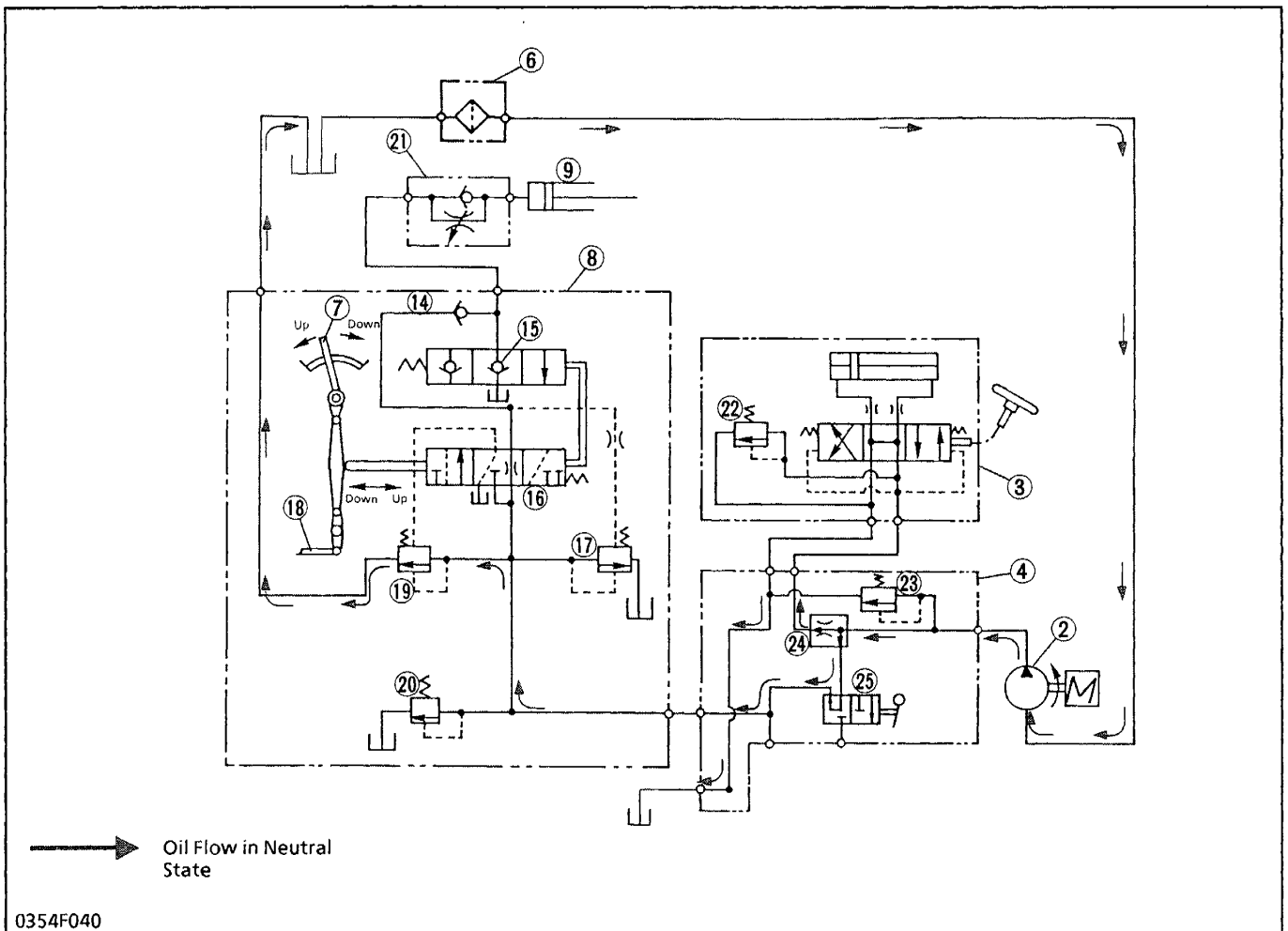

0354F040

■ B2150HST

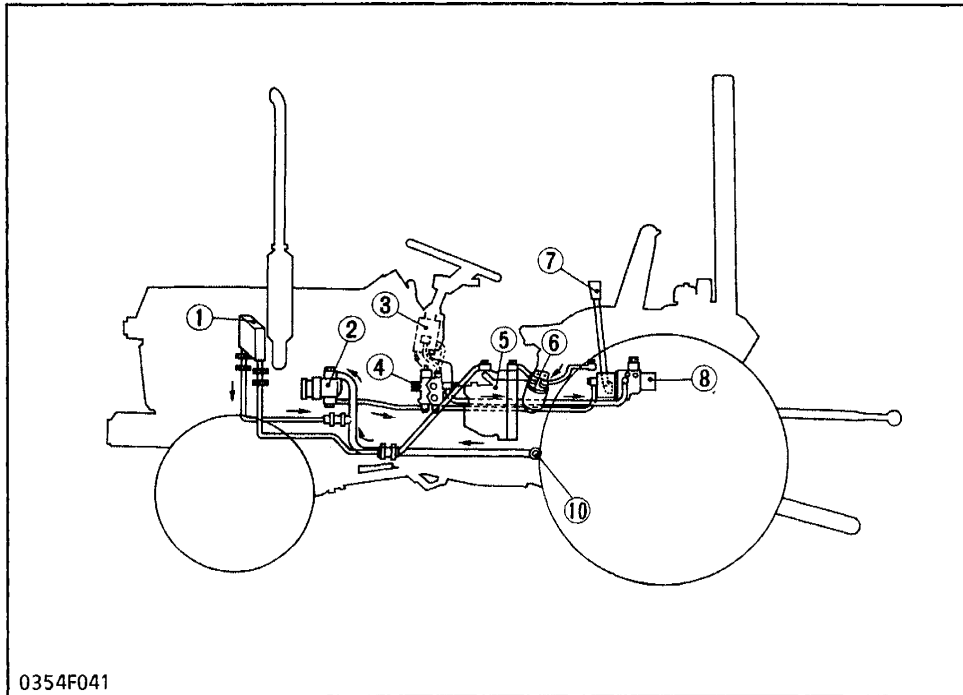

- (1) Cooler
- (2) Hydraulic Pump
- (3) Power Steering (Optional)
- (4) Hydraulic Block Type Outlet
- (5) Hydrostatic Transmission (HST)
- (6) Oil Filter (10 μm, 400 μin.)
- (7) Position Control Lever
- (8) Control Valve
- (9) Hydraulic Cylinder
- (10) Oil Strainer
- (11) Front Loader Control Valve (Optional)
- (12) Boom Cylinder (Optional)
- (13) Bucket Cylinder (Optional)
- (14) Check Valve 1
- (15) Check Valve 2
- (16) Main Control Valve
- (17) Unload Valve 2 (for shockless)
- (18) Feedback Rod
- (19) Unload Valve 1 (for unloading)
- (20) Relief Valve
- (21) Lowering Speed Control Valve
- (22) Relief Valve
- (23) Relief Valve
- (24) Flow Priority Valve
- (25) Directional Valve

0354F041

■ Hydraulic Circuit

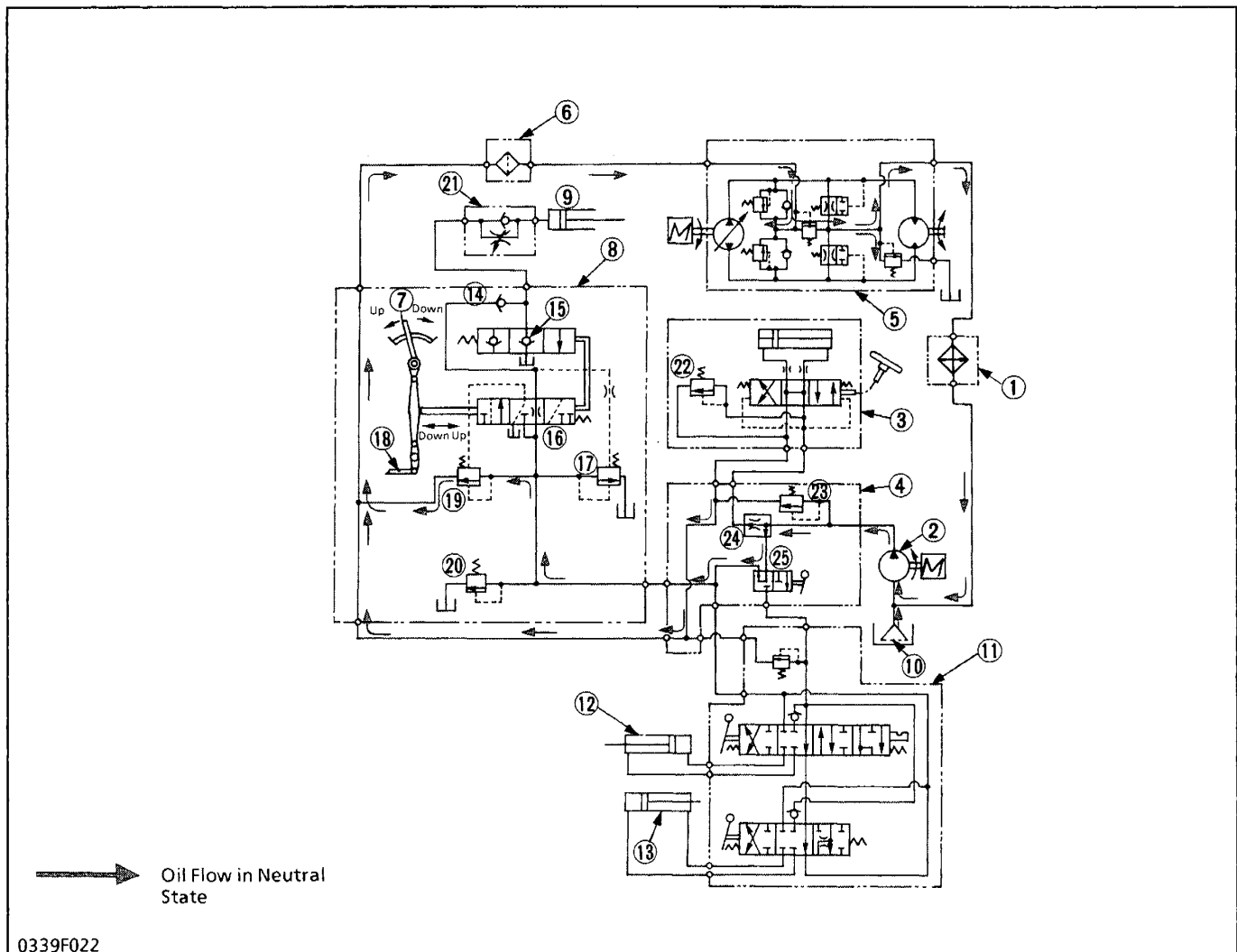

0339F022

Hydraulic System

The hydraulic system of these tractors are composed of a hydraulic pump (2), hydraulic block type outlet (4) control valve (8), hydraulic cylinder (9), hydraulic oil filters (6), (10) hydrostatic transmission (only for HST type), oil cooler (only for HST type) and other components shown in the figures.

This system has the following functions.

1. Position control of the rear implement connected to the 3-point hitch.
2. Hydraulic power takes off from the hydraulic block type outlet to operate the power steering (optional) and implements such as a front loader, front blade and etc.

- Oil is supplied by a hydraulic pump (2) connected to the engine. When an engine is started, a hydraulic pump (2) starts running, sucks oil from a transmission case and oil cooler (1) (only for HST). Oil is forced out to a control valve (8) through a hydraulic block type outlet (4) by a pump. This oil is sent to either hydraulic cylinder (9) or hydrostatic transmission. Only oil from a cylinder returns to a transmission case.
- Hydraulic power can be taken out easily through a hydraulic block type outlet to operate an optional power steering (3) or a hydraulic actuator of implements.

[1] HYDRAULIC PUMP

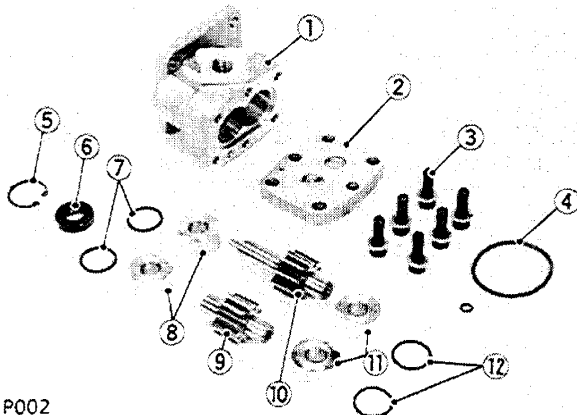

C021P002

[B1550-B1750-B1550HST-B1750HST]

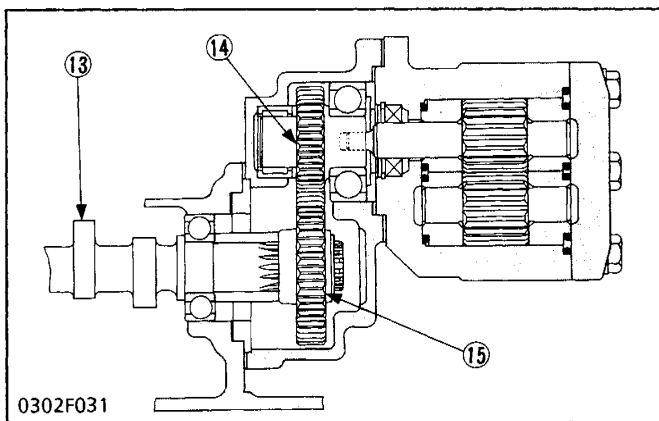

0302F031

[B2150-B2150HST]

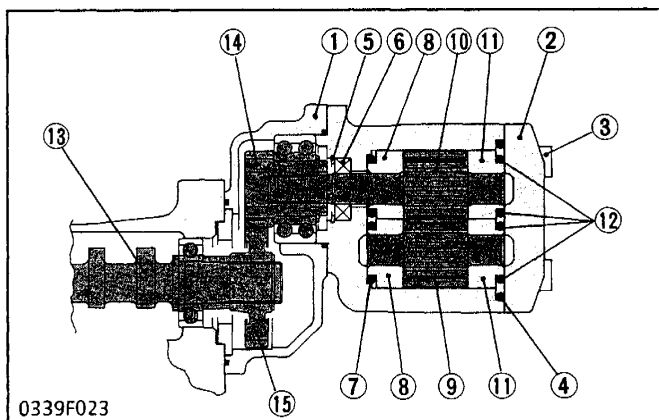

0339F023

The hydraulic pump is composed of the casing (1), end cover (2), bushing (8), (11), and two spur gears (drive gear (10) and driven gear (9)) that are in mesh.

Hydraulic pump is driven by the fuel camshaft (13) through the gears (14), (15).

Maximum displacement is as follows.

[B1550-B1750-B1550HST-B1750HST]

Displacement	Engine speed	Condition
21 l/min. 5.5 U.S. GPM 4.6 Imp. GPM	At 2600 rpm	13.2 MPa 135 kg/cm ² 1920 psi

[B2150-B2150HST]

Displacement	Engine speed	Condition
28.0 l/min. 7.4 U.S. GPM 6.2 Imp. GPM	At 2600 rpm	13.2 MPa 135 kg/cm ² 1920 psi

- (1) Casing
- (2) End Cover
- (3) Screws
- (4) O-ring
- (5) Internal Snap Ring
- (6) Oil Seal
- (7) O-ring
- (8) Bushing
- (9) Driven Gear
- (10) Drive Gear
- (11) Bushing
- (12) O-ring
- (13) Fuel Camshaft
- (14) 20T Gear
- (15) 27T Gear

This pump is a pressure loading type in which uses a bushing working against the gears to increase pump efficiency. A small amount of pressure oil is fed to outside of the bushings, pressing them against the gears and forming a tighter seal against leakage.

[2] CONTROL VALVE

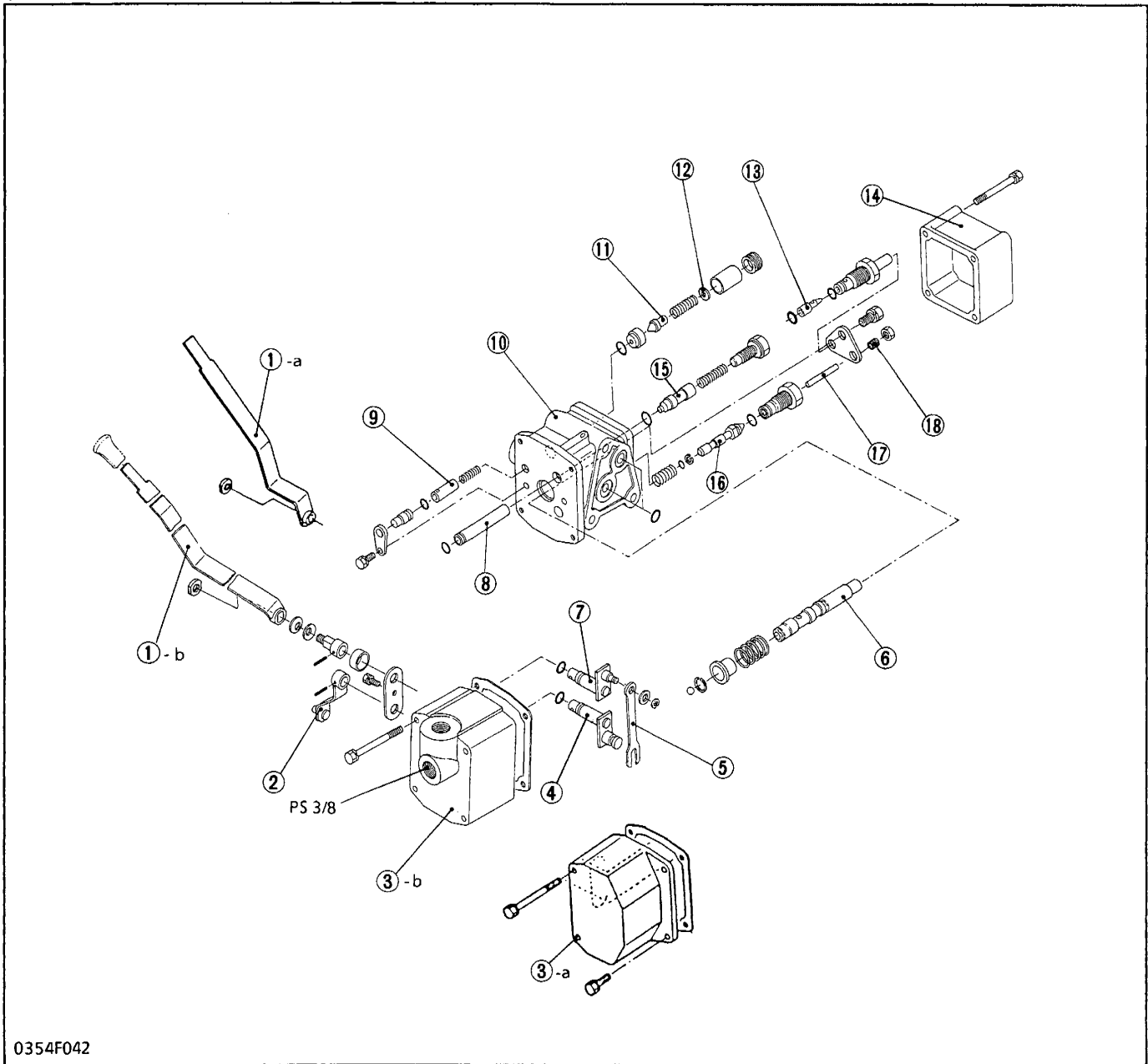

- | | | | |
|---|--------------------------|---------------------|-----------------------------------|
| (1)-a Position Control Lever
(for B1550-B1750-B1550HST-B1750HST) | (4) Feedback Lever Shaft | (10) Valve Body | (16) Check Valve 2 |
| (1)-b Position Control Lever
(for B2150-B2150HST) | (5) Spool Drive Lever | (11) Relief Valve | (17) Push Rod |
| (2) Feedback Arm | (6) Spool | (12) Adjusting Shim | (18) Screw (Neutral
Adjusting) |
| (3)-a Valve Cover (for
B1550-B1750-B1550HST-B1750HST-B2150) | (7) Control Lever Shaft | (13) Check Valve 1 | |
| (3)-b Valve Cover (for B2150HST) | (8) Pipe (for B2150HST) | (14) Relief Cover | |
| | (9) Unload Valve 2 | (15) Unload Valve 1 | |

Feature of this position control valve is smooth operation by built-in shockless mechanism.

However, it cannot take out optional aux. hydraulic power.

[2]-1 OIL FLOW

■ Neutral

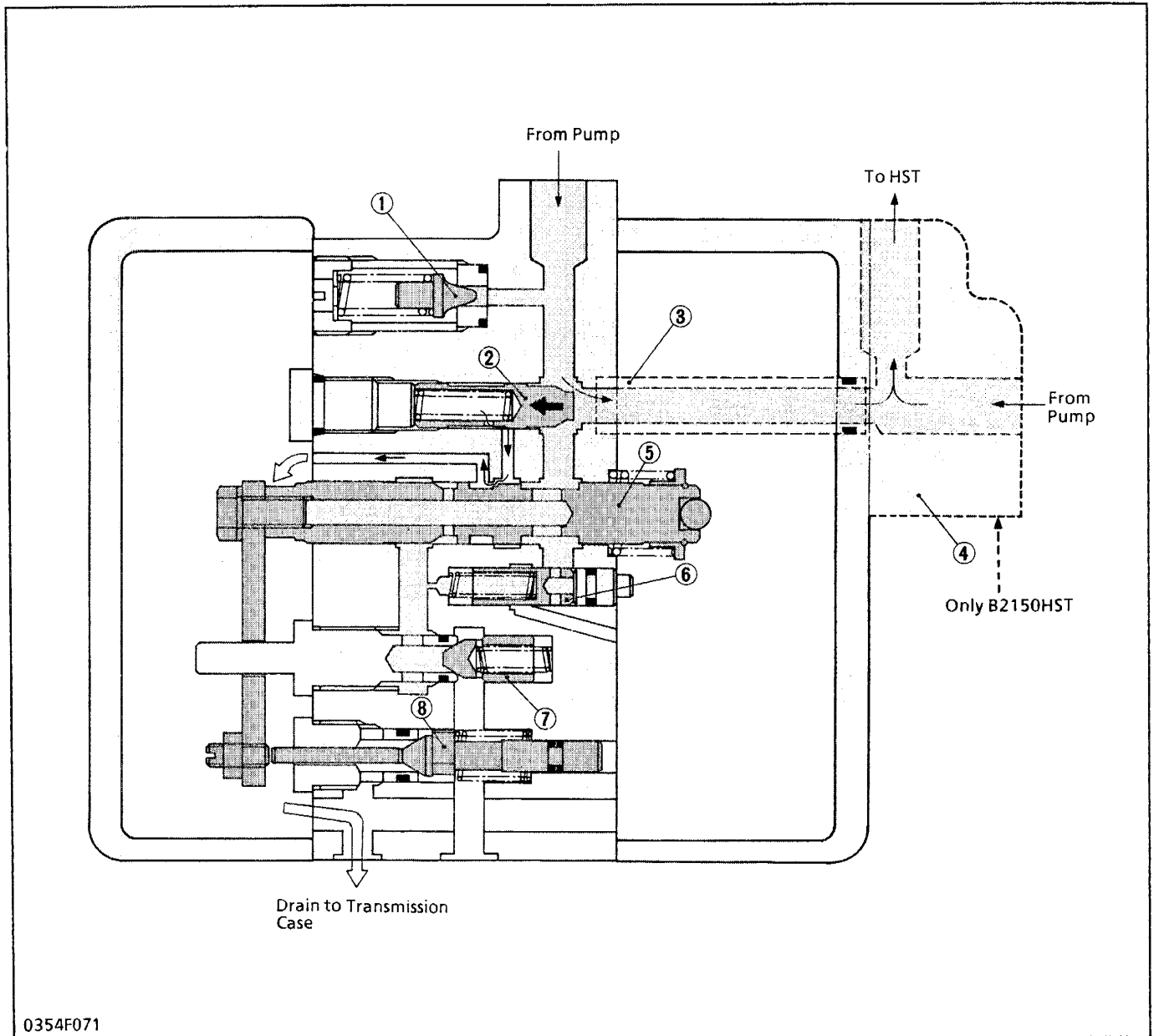

0354F071

- | | | | |
|--------------------|--------------------------------|--------------------|-------------------|
| (1) Relief Valve | (3) Pipe (for B2150HST) | (5) Spool | (7) Check Valve 1 |
| (2) Unload Valve 1 | (4) Valve Cover (for B2150HST) | (6) Unload Valve 2 | (8) Check Valve 2 |

In neutral, unload valve 1 (2) is opened by the pressure-fed oil against the spring since the back pressure side is opened to the tank port connected to transmission case to drain through the small groove of the spool (5).

And the oil in the hydraulic cylinder is kept by the check valve 1 (7) and check valve 2 (8) so that the implement does not lower or lift.

■ Lift

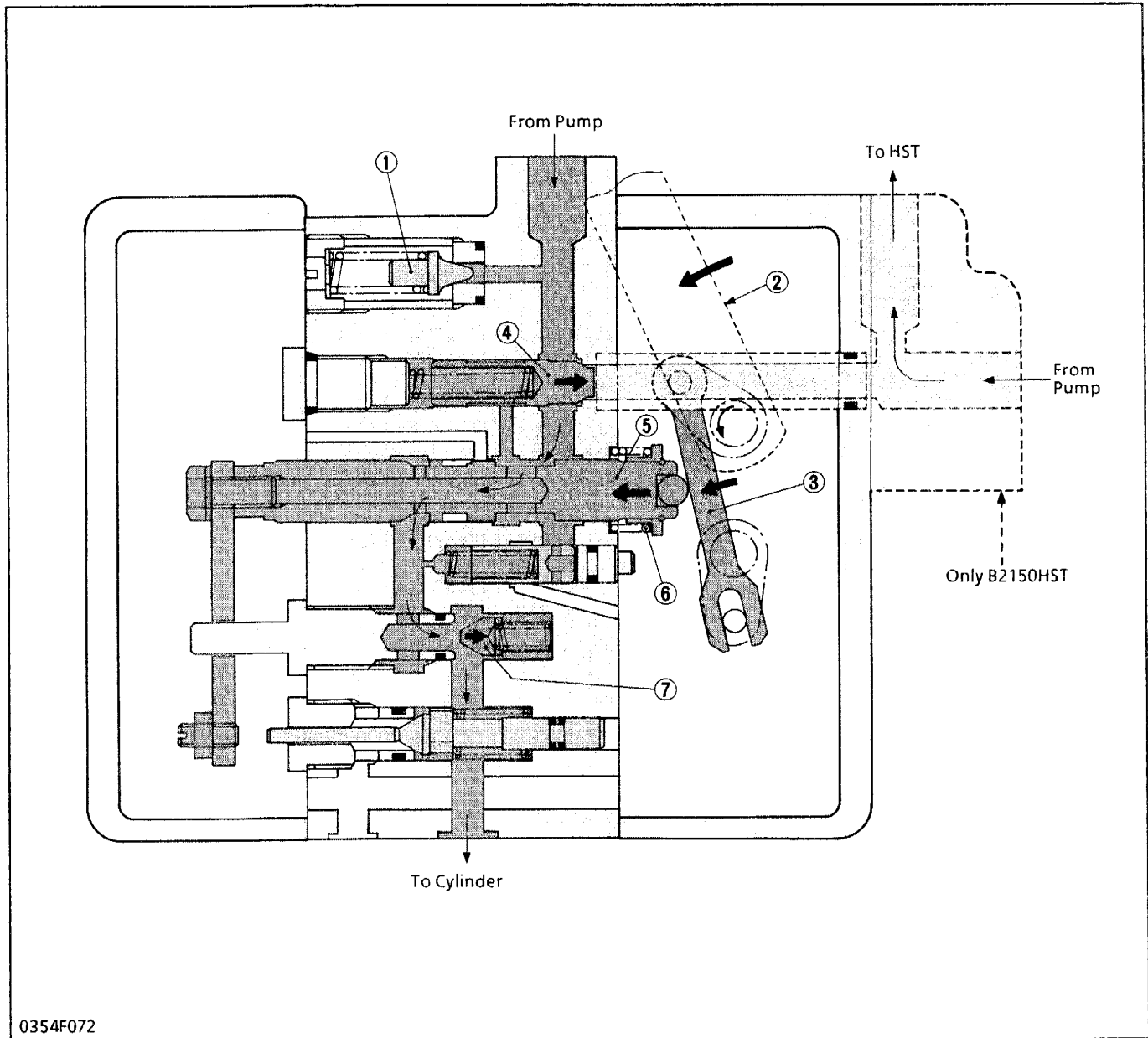

0354F072

- | | | | |
|----------------------------|-----------------------|-------------------|-------------------|
| (1) Relief Valve | (3) Spool Drive Lever | (5) Spool | (7) Check Valve 1 |
| (2) Position Control Lever | (4) Unload Valve 1 | (6) Return Spring | |

When the position control lever (2) is moved rearward, the spool (5) is pushed by the spool drive lever (3) against the return spring (6). At this time, the unload valve 1 (4) is closed because the back pressure rises since the back pressure side is led to the pump port through the groove of the spool(5).

Then the check valve 1 (7) is opened by the pressure and the oil fed from the pump flows to the

hydraulic cylinder to lift the implement connected to the 3-point hitch.

When operator stops moving the position control lever (2), by the feedback linkage and return spring (6), the spool (5) is automatically returned in neutral position. As a result, the implement height can be easily determined in proportion to the position of the control lever (2).

■ Shockless Mechanism at Lift Start and Lift End

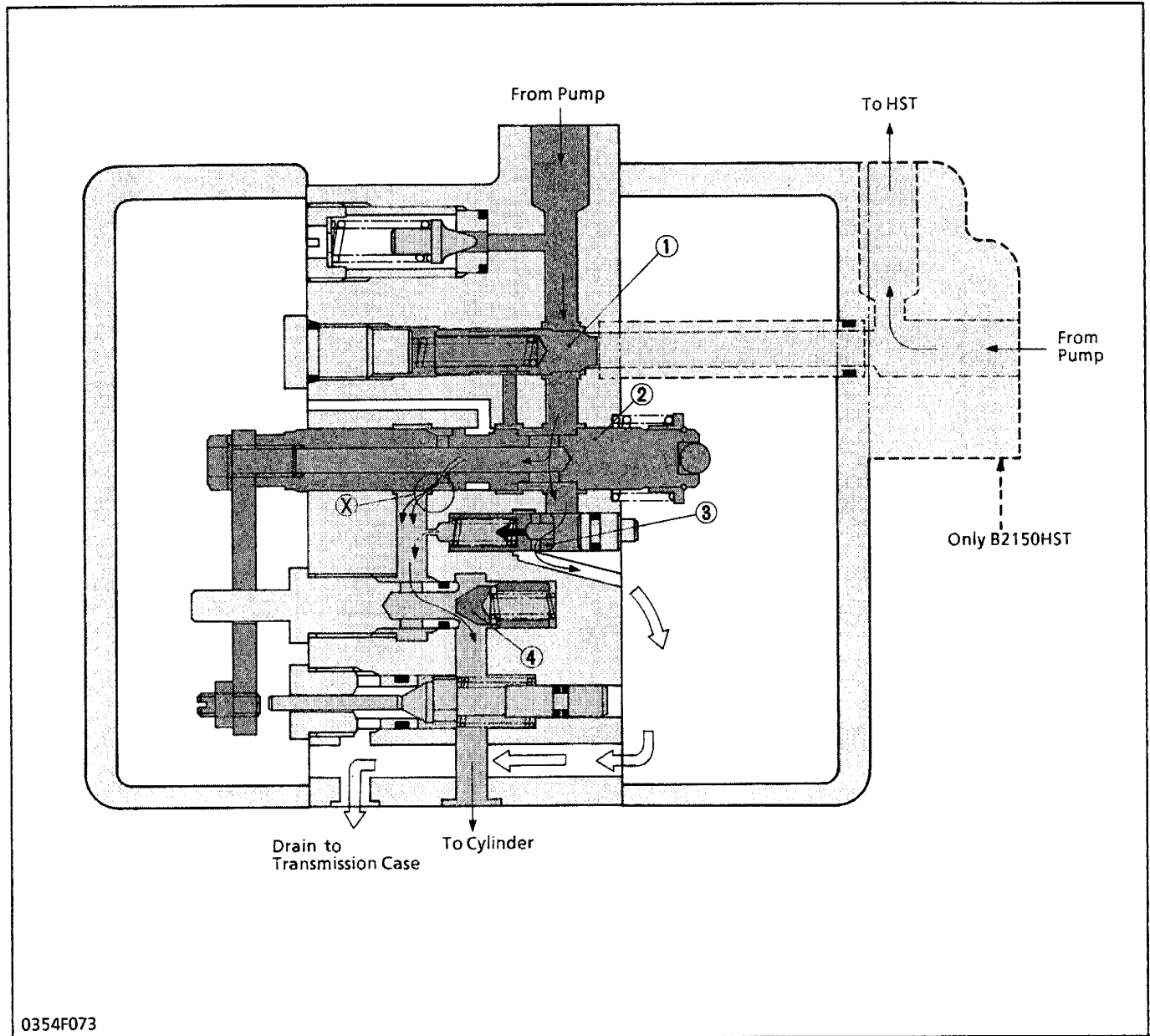

(1) Unload Valve 1

(2) Spool

(3) Unload Valve 2

(4) Check Valve 1

When the implement just starts being lifted and just before it stops lifting, shockless mechanism functions to reduce a sudden change of the oil pressure and flow. As a result, operator does not feel the unpleasant shock and can operate comfortably and position- control precisely.

At this short period, oil pass to the hydraulic cylinder is gradually narrowed by slant cut portion (X) of the spool (2). The sequence of the shockless mechanism is as follows. And as the oil pressure at the back pressure side of the unload valve 2 (3) becomes lower than that at pump port side, the unload valve 2 (3) is opened to drain pressure-fed oil to the transmission case.

	Unload Valve 1	Unload Valve 2
Neutral	Open	Closed
Lift Start		
Lift End	Closed	Open
Shockless		Closed
Lifting		Closed

■ Down

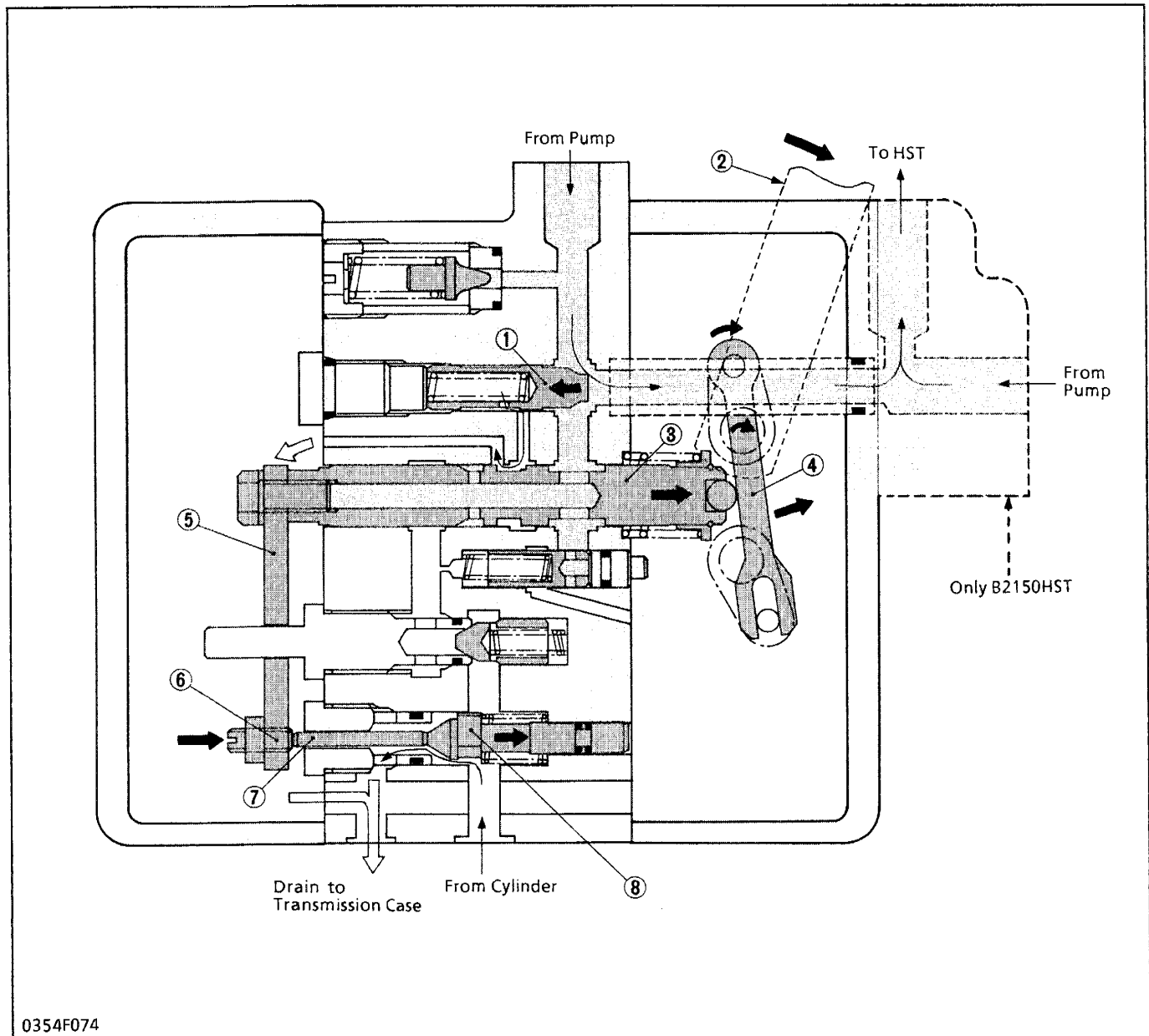

0354F074

- | | | | |
|----------------------------|-----------------------|-------------------------------|-------------------|
| (1) Unload Valve 1 | (3) Spool | (5) Connecting Plate | (7) Push Rod |
| (2) Position Control Lever | (4) Spool Drive Lever | (6) Screw (Neutral Adjusting) | (8) Check Valve 2 |

When the position control lever (2) is moved forward, the center of the spool drive lever (4) is moved forward and the spool (3) is pushed forward by the return spring on it.

At this time, the check valve 2 (8) is opened by the push rod (7) through the screw (6) and connecting plate (5) connected with the spool (3). Then the oil in the hydraulic cylinder drains to the transmission case through the cylinder port and tank port. And the implement lowers down.

Pressure-fed oil from the hydraulic pump pushes the unload valve 1 (1), and return to the transmission case or flows to the HST.

If the control lever (2) is stopped moving, by the feedback linkage, the spool (3) is automatically returned in neutral position.

As a result, the implement height can be easily determined in proportion to the position of the control lever (2).

[2]-2 FEEDBACK LINKAGE FOR POSITION CONTROL

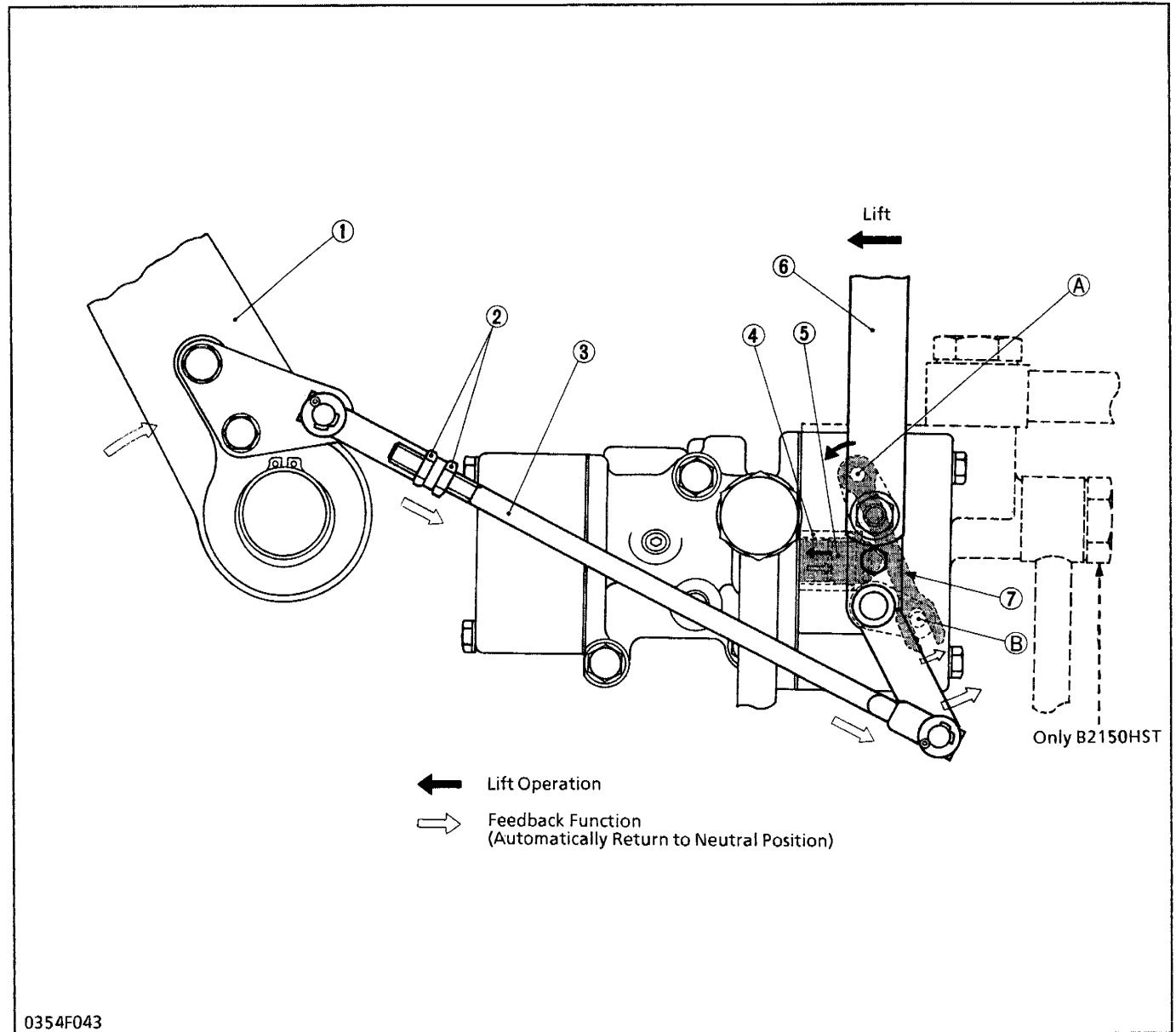

(1) Lift Arm RH
(2) Adjusting Nuts

(3) Feedback Rod
(4) Return Spring

(5) Spool
(6) Position Control Lever

(7) Spool Drive Lever

When the position control lever (6) is moved rearward to lift the implement, the spool drive lever (7) rotates around fulcrum (B) and pushes the spool (5) to form a raising circuit. And then lift arm RH (1) moves upward, the spool drive lever (7) is rotated around fulcrum (A) by the feedback rod (3). The

spool (5) is pushed out by the return spring (4) according to the motion of the spool drive lever (7).

As a result, implement height can be easily determined in proportion to the set position of the position control lever (6).

[3] HYDRAULIC BLOCK TYPE OUTLET

[B1550.B1750.B1550HST.B1750HST]

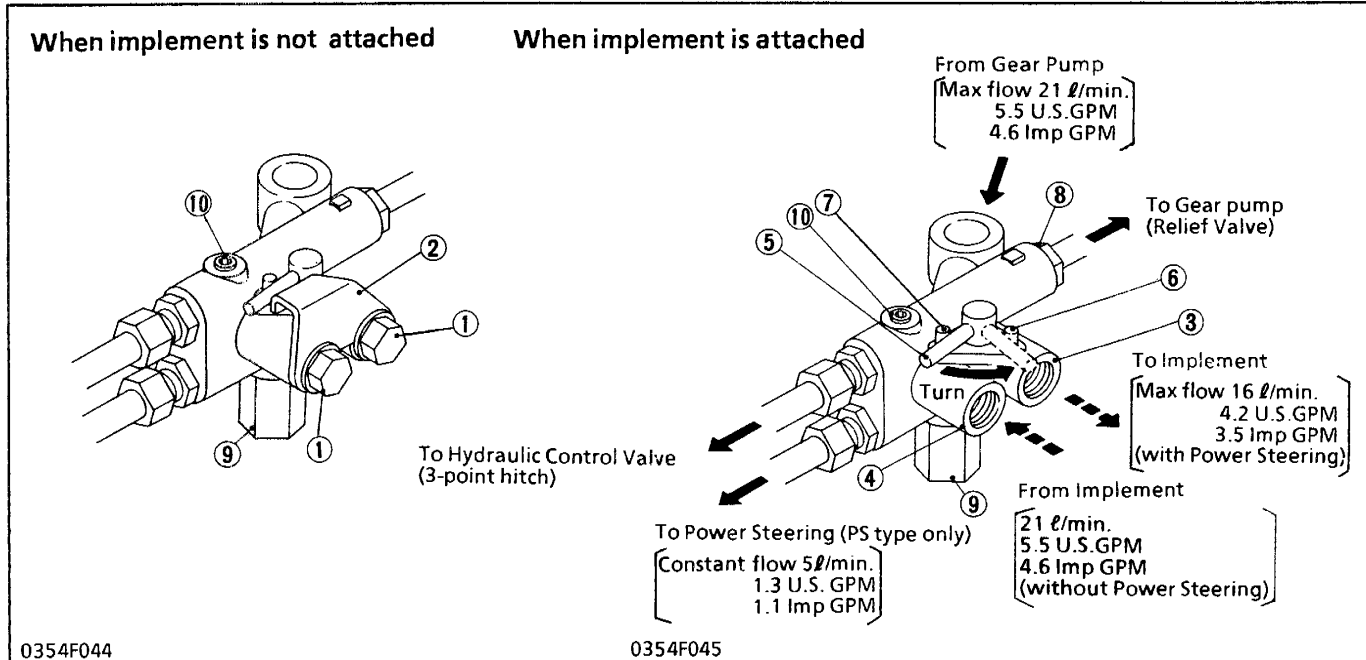

- (1) Plug (PS3/8)
- (2) Lock Plate
- (3) Outlet to Implements (PS 3/8")
- (4) Inlet from Implements (PS 3/8")
- (5) Directional Valve
- (6) Pin (Setting position for attaching implements)
- (7) Pin (Setting position for attaching no implement)
- (8) Relief Valve
- (9) Flow Priority Valve
- (10) Fixed Plug (PT 1/8")

The main components of the hydraulic block type outlet are shown in the figure. This hydraulic block type outlet is provided to take power out from the

tractor to operate the hydraulic cylinders on the implement, such as power steering and front loader, or front blade.

■ Flow Priority Valve

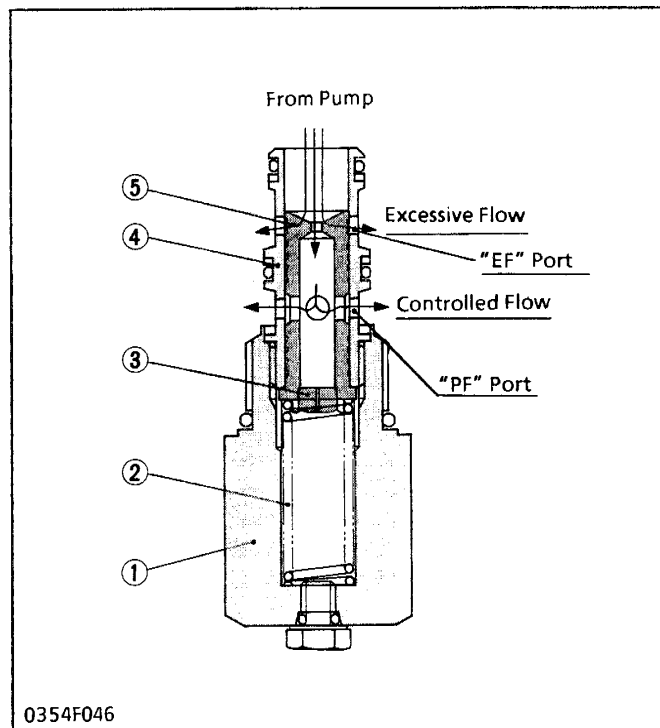

[Power Steering Type]

This valve is mounted on the hydraulic block type outlet for power steering type.

The flow priority valve consists of flow divider 1 (1), flow divider 2 (4), spool (5), spring (2) and damper (3). It is a flow divider that divides the oil flow (IN 21 ℓ/min., 5.5 U.S.GPM, 4.6 Imp.GPM) from a single hydraulic source (pump) to actuate two circuits simultaneously.

This valve is a priority flow divider in which a controlled flow (5 ℓ/min., 1.3 U.S.GPM, 1.1 Imp.GPM) is fed to the "PF" port and the excessive flow is fed to the "EF" port. The "PF" port can be optionally connected to the power steering. The "EF" port is connected to the hydraulic control valve or optional implement's control valve.

The damper (3) reduces the vibration of the spool (5). That vibration is caused by a change in the oil flow when the engine speed is changed rapidly.

- (1) Flow Divider 1
- (2) Spring
- (3) Damper
- (4) Flow Divider 2
- (5) Spool

■ Plug (Without Flow Priority Valve)

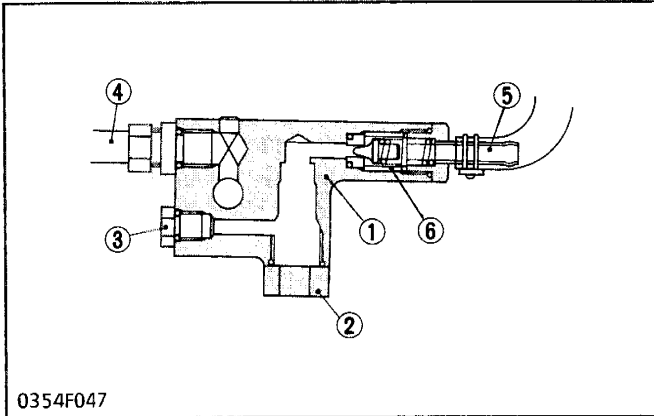

[Manual Steering Type]

This is mounted on the hydraulic block type outlet for manual steering type instead of the flow priority valve.

- (1) Hydraulic Block Type Outlet
- (2) Plug (M24 Pitch 1.5 mm)
- (3) Plug (PS 1/4")
- (4) Outlet to Hydraulic Control Valve (PS 3/8")
- (5) Outlet to Gear Pump (M20 Pitch 1.5 mm)
- (6) Relief Valve

■ Standard Oil Circuit

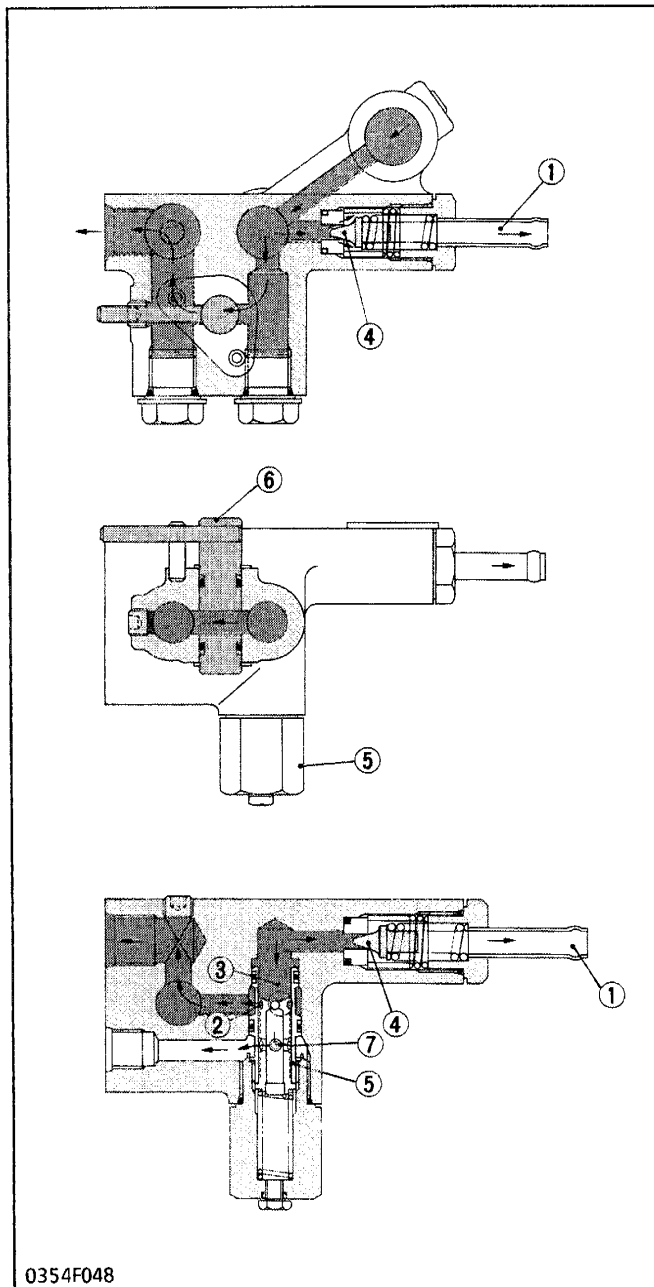

The total flow of oil (21 l/min., 5.5 U.S. GPM, 4.6 Imp. GPM), pressure-fed from the hydraulic pump, enters into the "IN" port through the route as shown left.

A portion of oil flow-controlled by the orifice runs to the power steering and return to the transmission case.

On the other hand as the oil passes the orifice, a pressure difference is created between the ends of the orifice. This causes the spring to deflect causing the spool to move downward. As a result, the excessive oil runs into "EF" port and to the control valve.

- (1) RE Port (to hydraulic pump)
- (2) "EF" Port
- (3) "IN" Port
- (4) Relief Valve
- (5) Flow Priority Valve
- (6) Directional Valve
- (7) "PF" Port

■ Oil Circuit for Power Steering Type

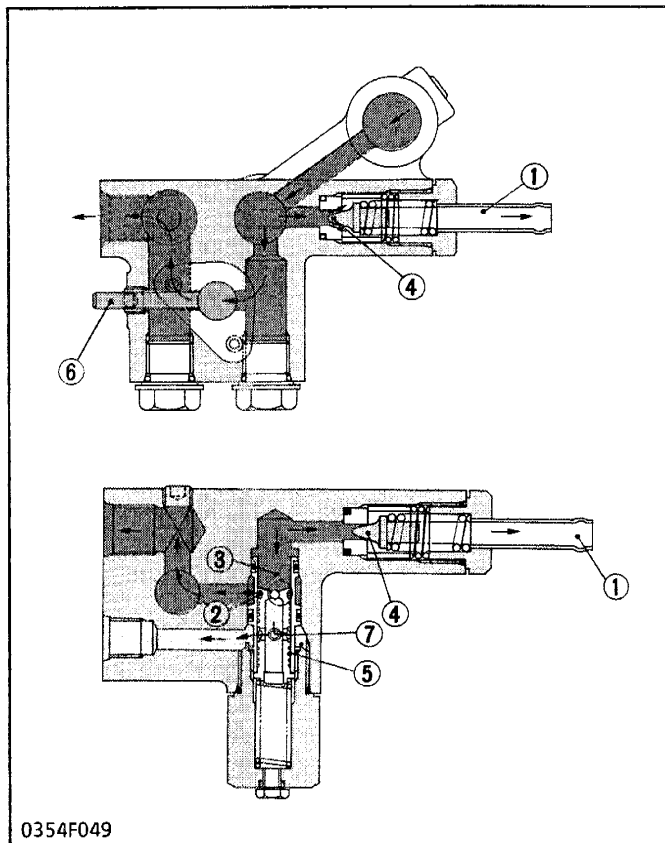

The total flow of oil pressure-fed from the hydraulic pump enters "IN" port through the route as shown above.

A flow-controlled oil of 5 ℓ/min.(1.3 U.S.GPM, 1.1 Imp.GPM) enters into the "PF" port through the orifice in the spool. Then this oil enters into the power steering circuit and is used to operate the power steering.

The excessive oil in the "IN" port runs into the "EF" port, and to the control valve.

- (1) RE Port
- (2) EF Port
- (3) IN Port
- (4) Relief Valve
- (5) Flow Priority Valve
- (6) Directional Valve
- (7) PF Port

■ When Using Front Loader or Other Implements

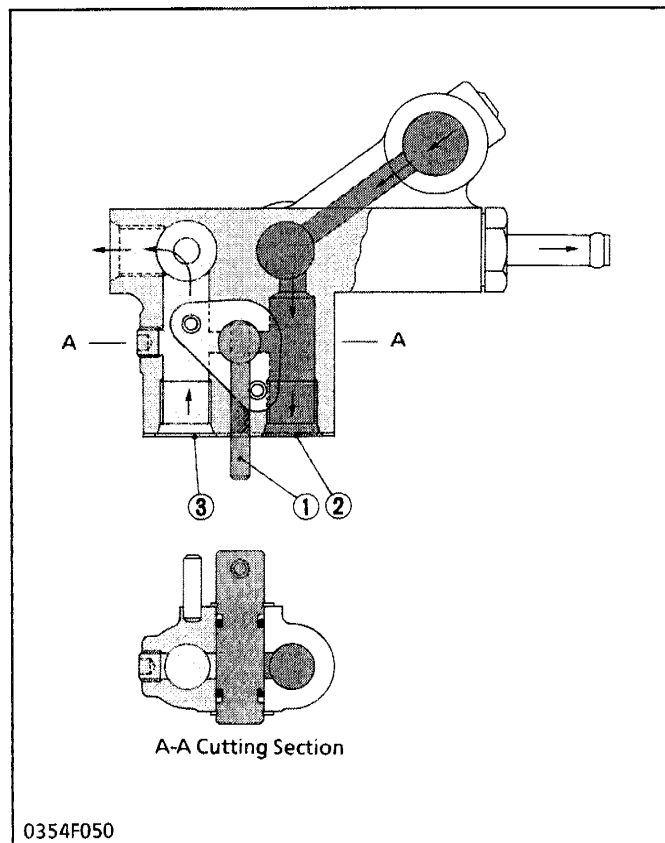

When using the front loader or other implement, remove the plugs. Connect the implement's inlet pipe to A port (2), the outlet pipe to the B port (3). And turn the directional valve (1) counterclockwise to the end.

The oil pressure-fed from the hydraulic pump enters into the "IN" port.

Prior to the other control valves, the oil flow-controlled by the orifice runs to the power steering through the "PF" port. This capacity is 5 ℓ/min.(1.3 U.S.GPM, 1.1 Imp.GPM).

Excessive oil pushes the spool and flows to the front loader control valve through the "EF" port. Then the oil returns to B port of the hydraulic block type outlet. And this oil runs to the rear control valve.

- (1) Directional Valve
- (2) A Port
- (3) B Port

[3] HYDRAULIC BLOCK TYPE OUTLET (Continued)

[B2150.B2150HST]

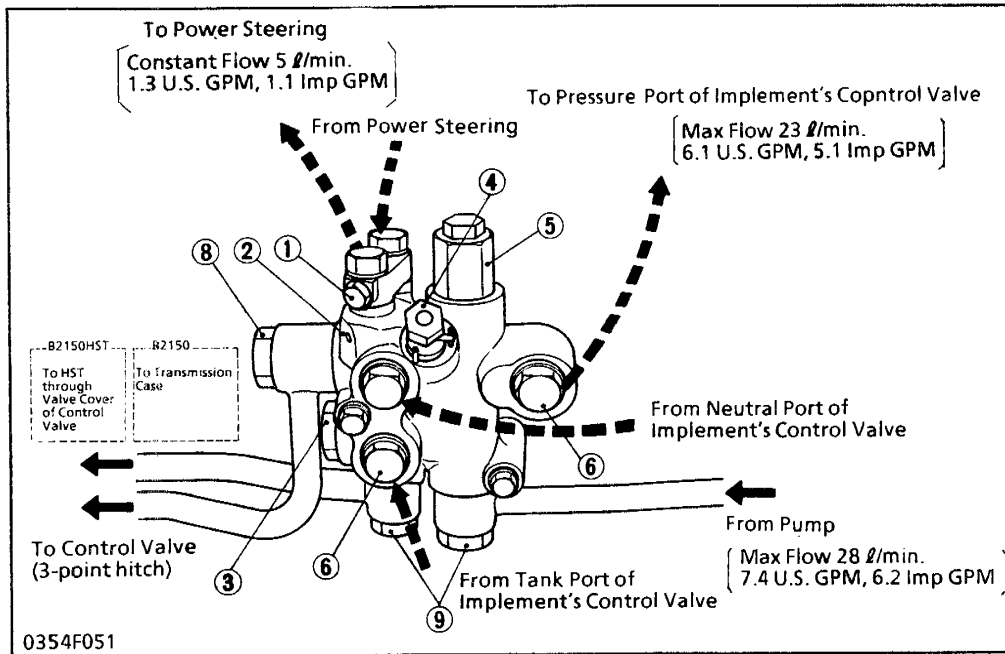

The main components of the hydraulic block type outlet are shown in the figure. This hydraulic block type outlet is provided to take power out from the

tractor to operate the hydraulic cylinders on the implement, such as power steering and front loader, or front blade.

■ Flow Priority Valve

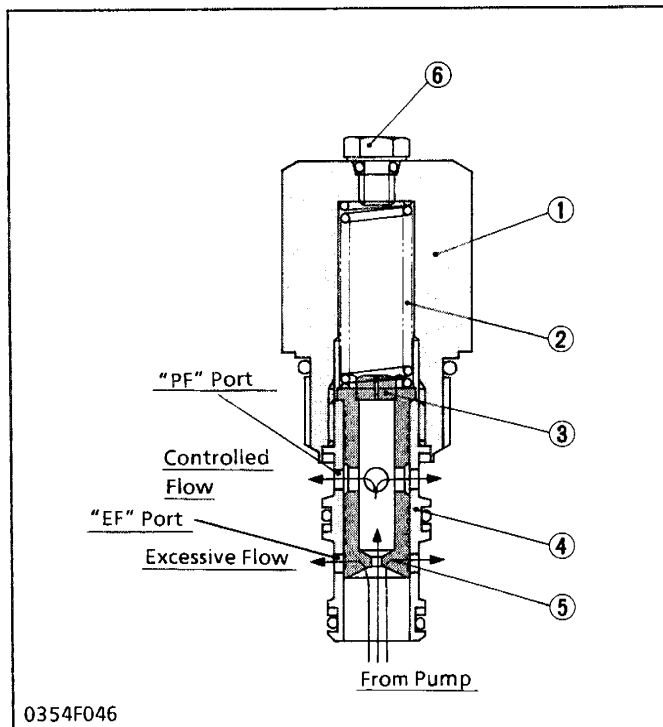

The flow priority valve consists of flow divider 1 (1), flow divider 2 (4), spool (5), spring (2) and damper (3). It is a flow divider that divides the oil flow (IN 28 l/min., 7.4 U.S.GPM, 6.2 Imp.GPM) from a single hydraulic source (pump) to actuate two circuits simultaneously.

This valve is a priority flow divider in which a controled flow (5 l/min., 1.3 U.S.GPM, 1.1 Imp.GPM) is fed to the "PF" port and the excessive flow is fed to the "EF" port. The "PF" port can be optionally connected to the power steering. The "EF" port is connected to the hydraulic control valve or optional implement's control valve.

The damper (3) reduces the vibration of the spool (5). That vibration is caused by a change in the oil flow when the engine speed is changed rapidly.

- | | |
|--------------------|---------------------------|
| (1) Flow Divider 1 | (4) Flow Divider 2 |
| (2) Spring | (5) Spool |
| (3) Damper | (6) Plug for Air Bleeding |

■ Standard Oil Circuit

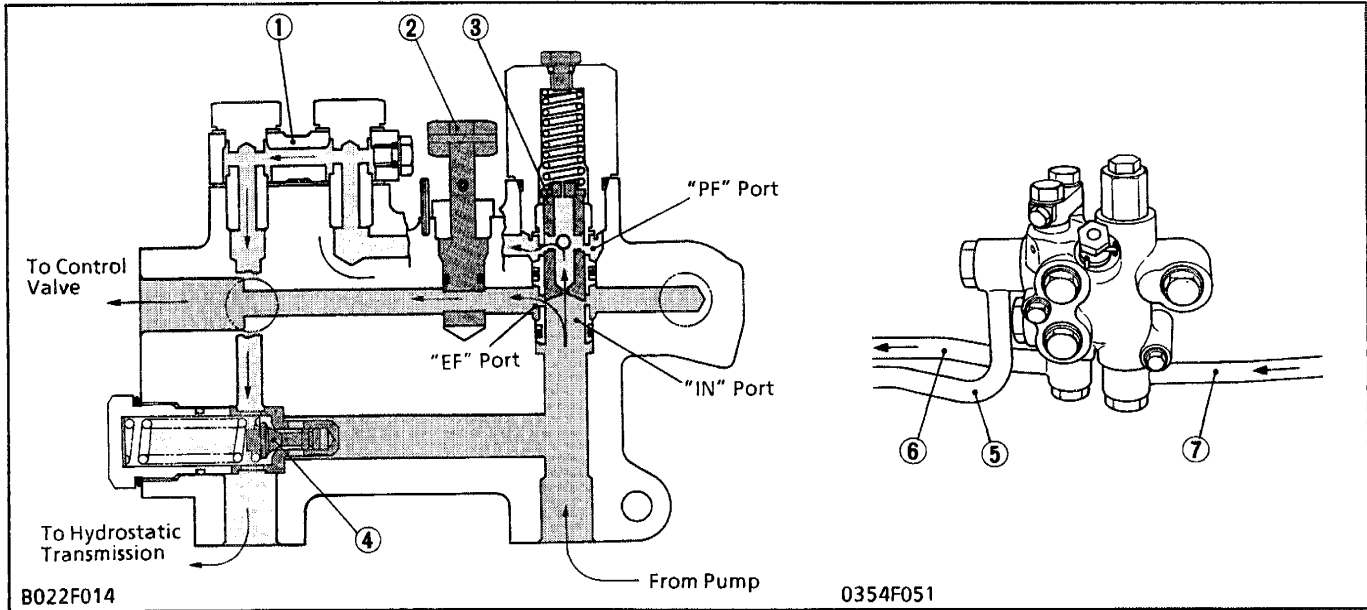

- (1) Cap
- (2) Directional Valve
- (3) Flow Priority Valve
- (4) Relief Valve
- (5) Delivery Pipe 2
- (6) Return.Pipe 1
- (7) Delivery Pipe 1

The total flow of oil (28 l/min., 7.4 U.S.GPM, 6.2 Imp.GPM), pressure-fed from the hydraulic pump, enters into the "IN" port through the route shown above.

A portion of oil flow-controlled by the orifice runs to the bypass in the cap (1) and return pipe 1 (6) through the "PF" port. And this oil finally flows to the hydrostatic transmission through the control

valve cover and oil filter.

On the other hand as the oil passes the orifice, a pressure difference is created between the ends of the orifice. This causes the spring to deflect causing the spool to move upward. As a result, the excessive oil runs into the "EF" port, and to the control valve (hydraulic raising/lowering circuit) via delivery pipe 2 (5).

■ Oil Circuit for Power Steering Type

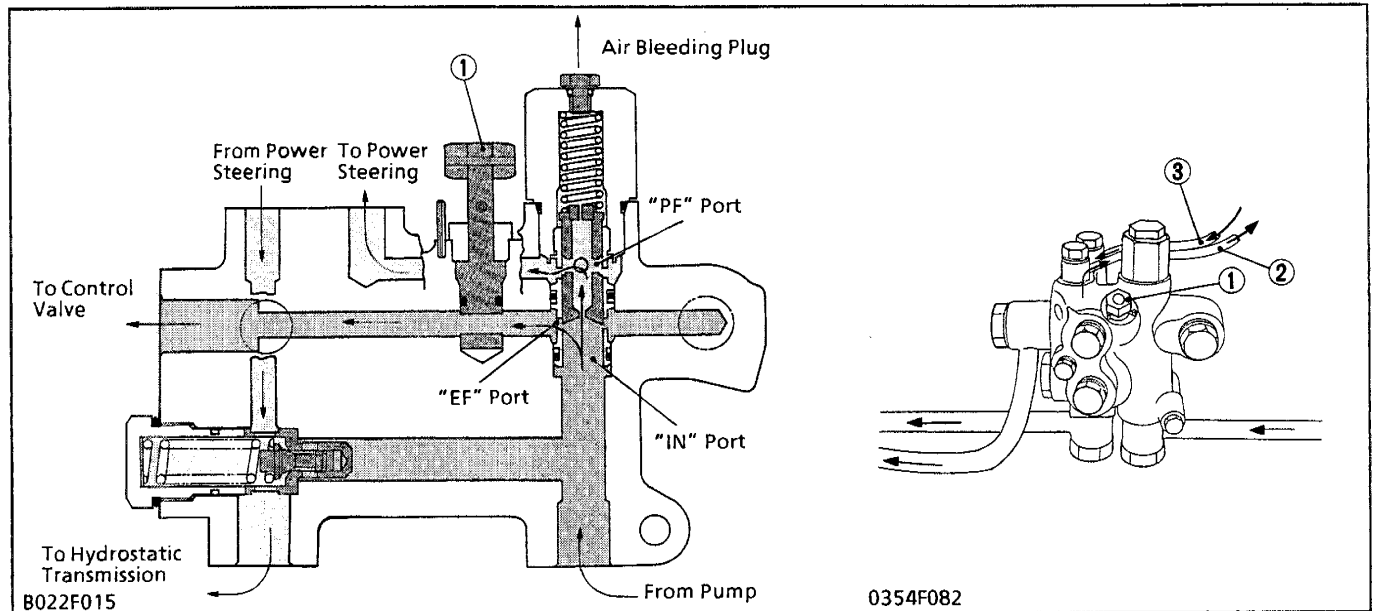

(1) Directional Valve

(2) Delivery Pipe

(3) Return Pipe

The total flow of oil pressure-fed from the hydraulic pump enters "IN" port through the route as shown above.

A flow-controlled oil of 5 l/min.(1.3 U.S.GPM, 1.1 Imp.GPM) enters into the "PF" port through the orifice in the spool. Then this oil enters into the power steering circuit and is used to operate the

power steering. The return oil finally flows to the hydrostatic transmission through the control valve cover and oil filter.

The excessive oil in the "IN" port runs into the "EF" port, and to the control valve (hydraulic raising/lowering circuit) via delivery pipe 2.

■ When Using Front Loader or Other Implement

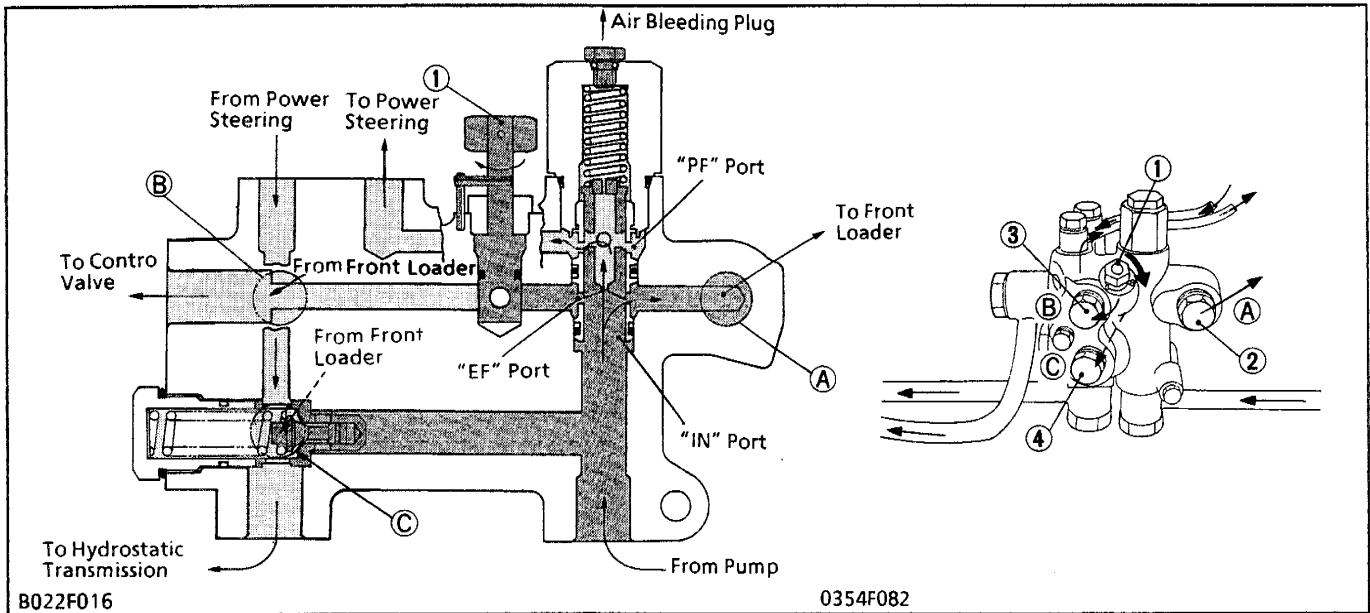

- (1) Directional Valve
- (2) Bolt
- (3) Bolt
- (4) Bolt

When using the front loader or other implement, remove the bolts (2), (3) and (4). Connect the implement's inlet pipe to (A) position, the outlet pipe to the (B) position, and the drain pipe to the (C) position. And turn the directional valve (1) clockwise to the end.

The oil pressure-fed from the hydraulic pump enters into the "IN" port.

Prior to the other control valves, the oil flow-

controlled by the orifice runs to the power steering through the "PF" port. This capacity is 5 l/min.(1.3 U.S.GPM, 1.1 Imp.GPM).

Excessive oil pushes the spool and flows to the front loader control valve through the "EF" port. Then the oil returns to (B) position of the hydraulic block type outlet. And this oil runs to the rear control valve. The relieved oil returns to (C) position and joins to return oil of power steering.

[4] OIL COOLER (ONLY FOR HST TYPE)

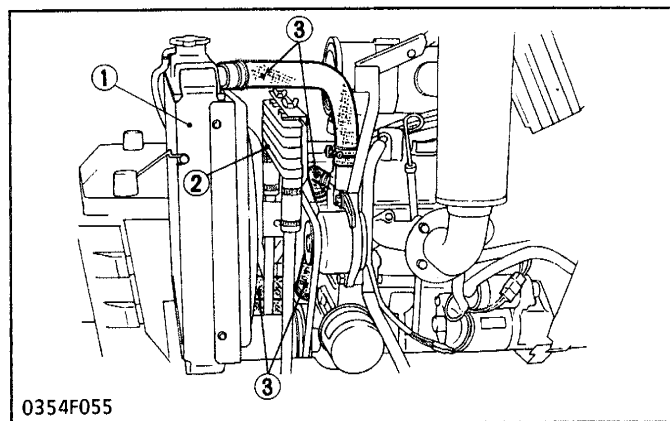

- (1) Radiator
- (2) Oil Cooler
- (3) Radiator Hoses

Hydrostatic transmission produces the heat more than normal circulation of oil dissipates, then this tractor is equipped with a oil cooler.

The oil cooler is located between the engine and engine radiator and of air-to-oil type, so that air blast by fan dissipates the heat from oil through the oil tubes with fin of the cooler.

The dimension of oil coolers is as follows.

	Oil cooler of B1550HST-B1750HST	Oil cooler of B2150HST
Core type	Louverless corrugated fin	Louverless corrugated fin
Core dimension	W: 200 mm, H: 70 mm, D: 32 mm	W: 200 mm, H: 115 mm, D: 32 mm
Cooler screen setting space	100 mm	100 mm
Cooler screen setting screw	M6 Pitch 1.0 mm	M6 Pitch 1.0 mm

B&W 11x17

INSERT

M.9-1

THROUGH

M.9-4

[2] STARTING SYSTEM

Main Switch Table					
Key Position	Terminal	B (30)	AC	G (19)	ST (50)
OFF		●			
ON		●	●		
PREHEAT		●	●	●	
START		●	●	●	●

At the "PREHEAT" Position

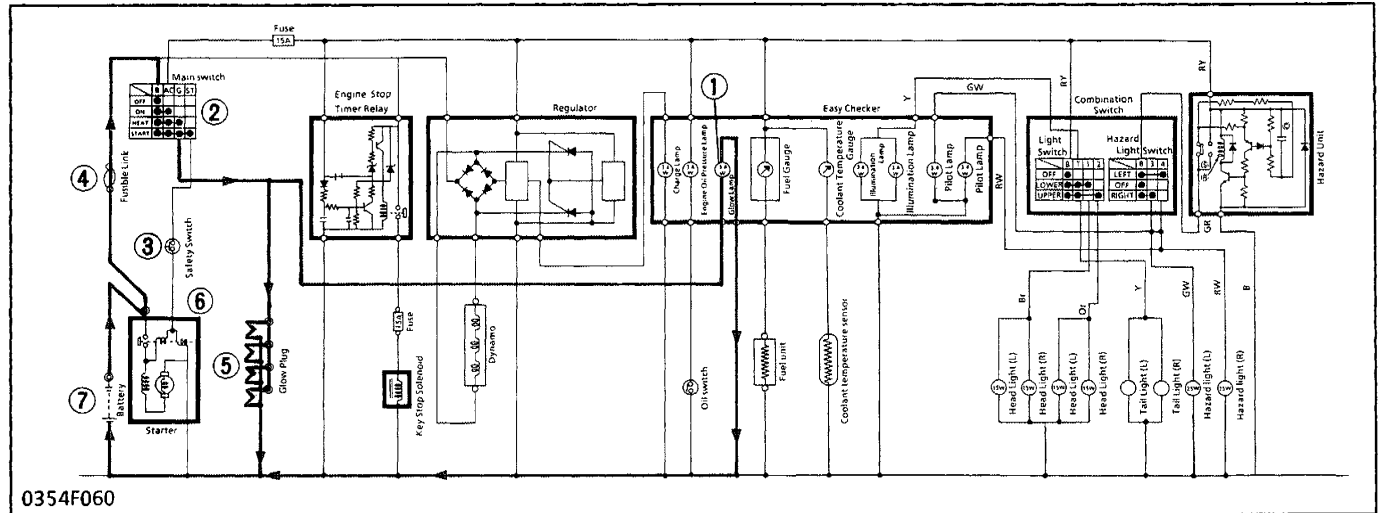

At the "START" Position

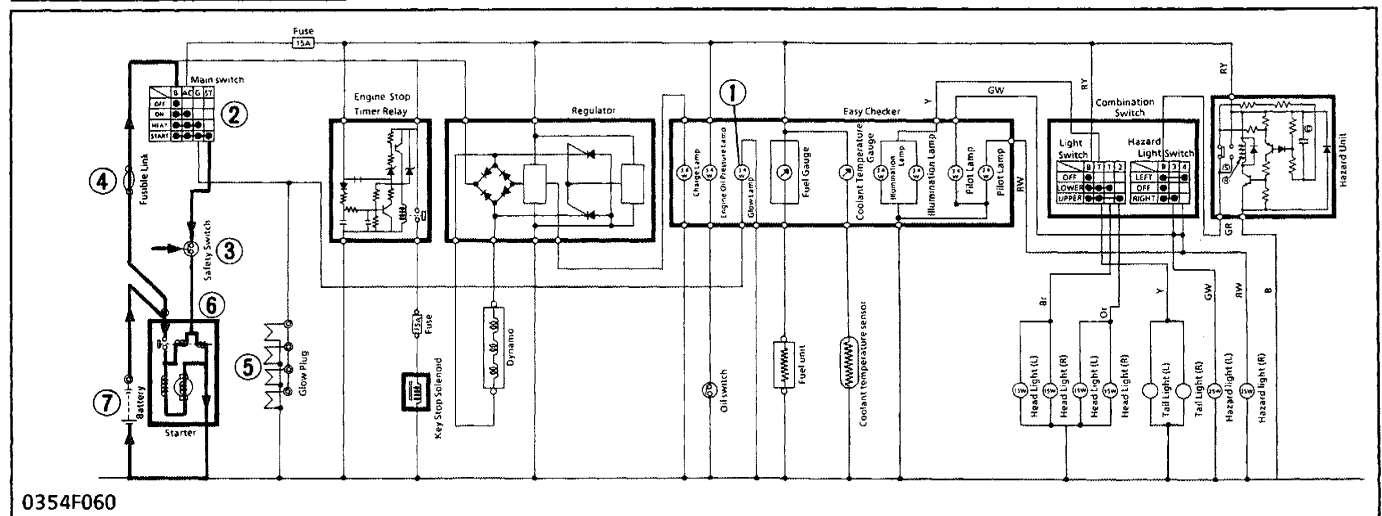

- (1) Glow Plug Indicator Lamp
- (2) Main Switch
- (3) Safety Starter Switch
- (4) Fusible Link
- (5) Glow Plugs
- (6) Starter Motor
- (7) Battery

When the main switch (2) is turned to the PREHEAT position, the terminal B is connected to the terminals G and AC. The glow plugs (5) become red-hot, and at the same time, the glow plug indicator lamp (1) also lights on to indicate the red-hot condition of the glow plugs.

When the main switch is then turned to the START position with the safety starter switch (3) on,

the terminal B is connected to the terminals ST and AC so that the starter motor (6) begins running and the glow plugs are kept red-hot.

The main switch automatically returns to the ON position, the terminal B is connected only to the terminal AC, thereby causing the starting circuit to be opened, stopping the starter motor.

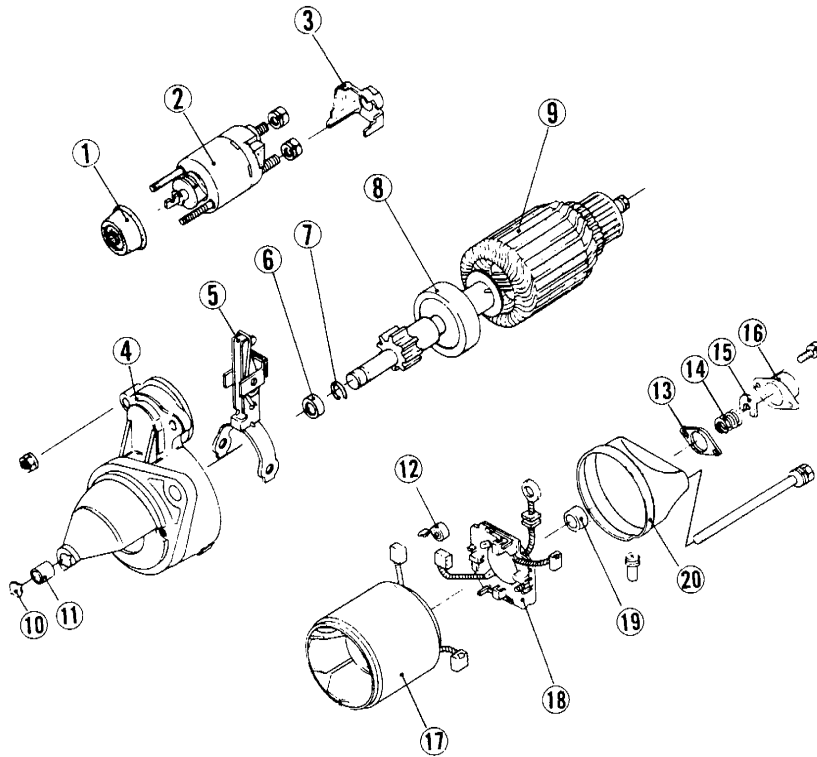
(1) Starter**[B1550-B1750-B1550HST-B1750HST]**

0319F051

- | | | | |
|---------------------|------------------------|-------------------|--------------------|
| (1) Cover | (6) Bushing | (11) Bushing | (16) End Frame Cap |
| (2) Magnet Switch | (7) Snap Pin | (12) Brush Spring | (17) Yoke |
| (3) Cord Cover | (8) Overrunning Clutch | (13) Gasket | (18) Brush Holder |
| (4) Drive End Frame | (9) Armature | (14) Brake Spring | (19) Bushing |
| (5) Drive Lever | (10) Cover | (15) Brake Shoe | (20) End Frame |

The starter is composed of a starting motor and a magnet switch.

(1)-1 Starting Motor

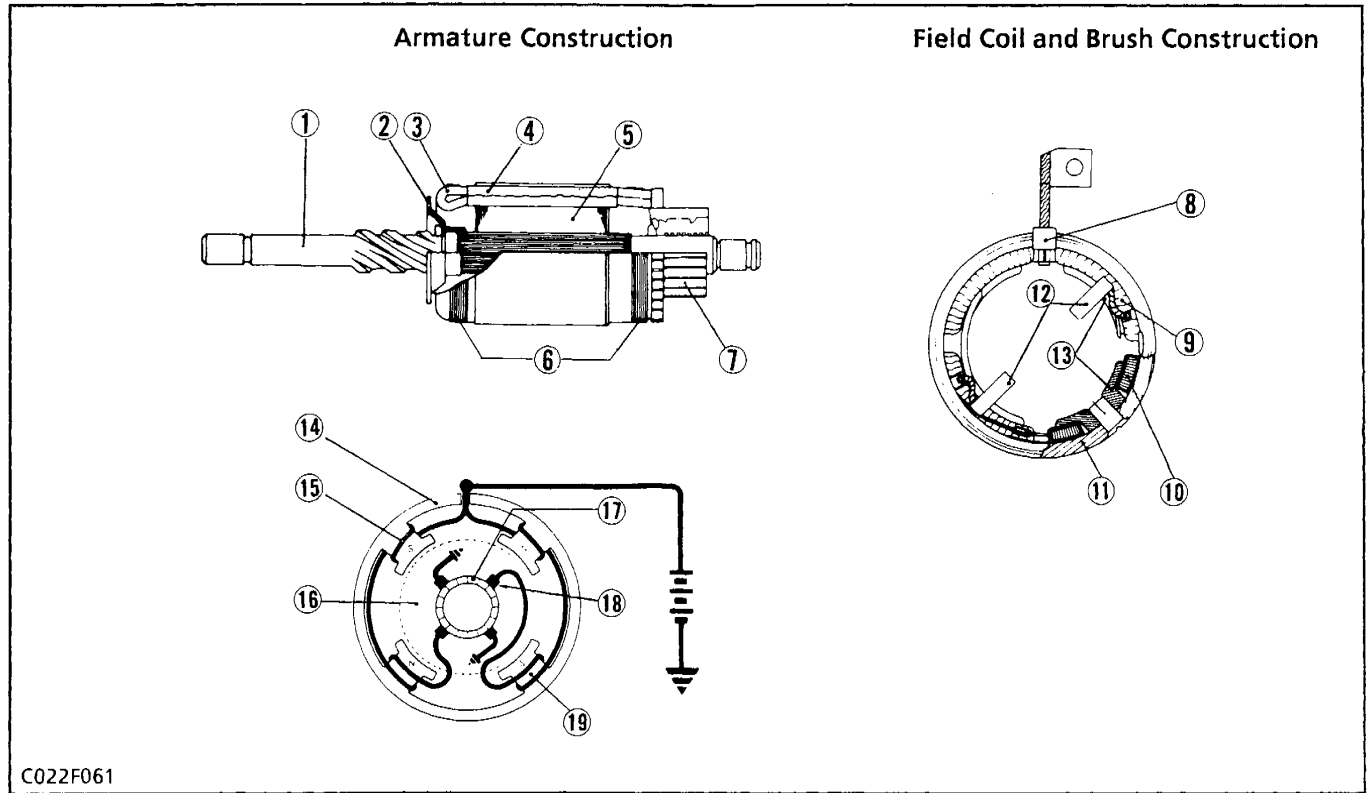

- | | | | |
|--------------------|--------------------|----------------|-----------------|
| (1) Armature Shaft | (6) Hemp String | (11) Yoke | (16) Armature |
| (2) Stopper | (7) Commutator | (12) Yoke | (17) Commutator |
| (3) Coil | (8) Rubber Bushing | (13) Pole Core | (18) Brush |
| (4) Slot Insulator | (9) Cotton Tape | (14) Yoke | (19) Pole Core |
| (5) Armature Core | (10) Flat Wire | (15) Coil | |

The starting motor converts the electrical energy into rotary mechanical energy to crank the engine, and is composed of an armature, commutator, field coil, brushes and others.

(1)-2 Overrunning Clutch

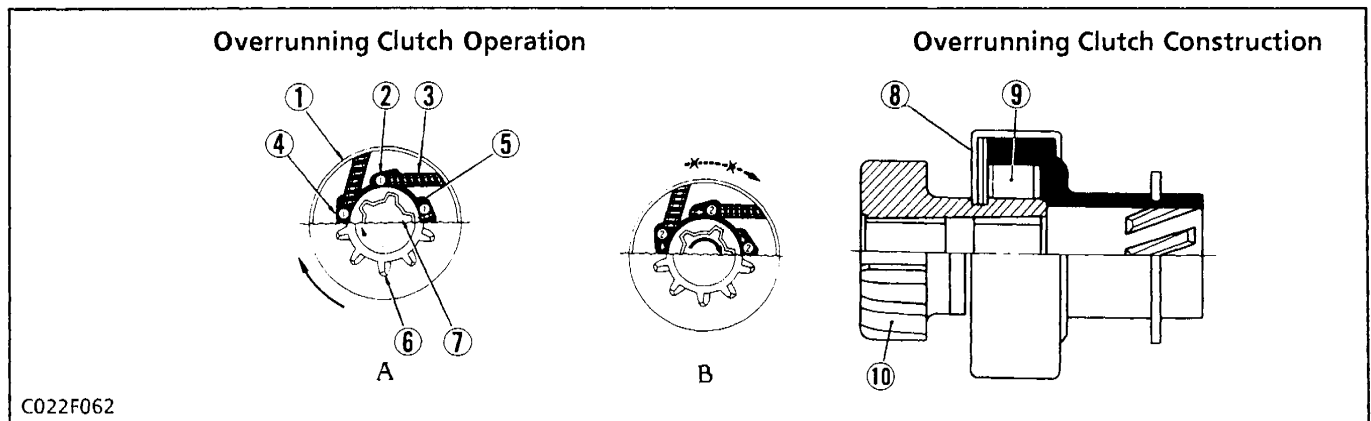

- | | | | |
|-----------------------|-----------------------|-----------------------------------|------------------|
| (1) Clutch Gear Outer | (4) Locked Condition | (7) Pinion Shaft with Pinion Gear | (10) Pinion Gear |
| (2) Roller | (5) Spline Tube Inner | (8) Clutch Cover | A: When Locked |
| (3) Roller Spring | (6) Pinion Gear | (9) Clutch Roller | B: When Idling |

Clutch allows positive meshing and demeshing of the pinion gear with the ring gear.

[B1550-B1750-B1550HST-B1750HST] (Continued)

(1)-3 Magnet Switch

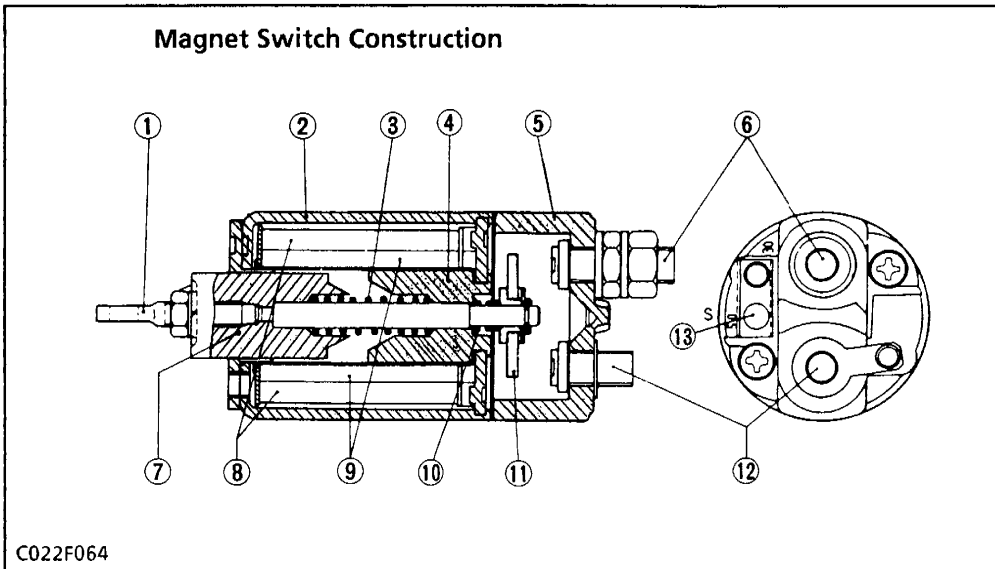

- (1) Joint
- (2) Switch Housing
- (3) Return Spring
- (4) Magnetic Core
- (5) Switch Cover
- (6) Power Supply Terminal
- (7) Plunger (Moving Core)
- (8) Holding Coil
- (9) Pull-in Coil
- (10) Spring
- (11) Contact Plate
- (12) Connecting Lead Terminal
- (13) Starter Switch Terminal

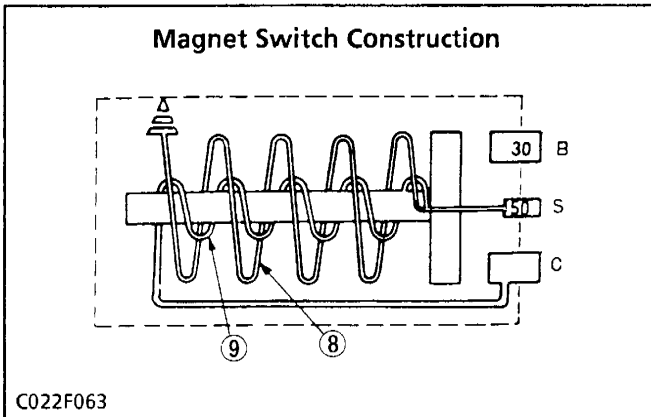

The magnet switch completes the circuit from the battery to the starting motor, engaging the pinion gear with the ring gear, and is composed of a pull-in coil (9), holding coil (8), plunger (7), drive lever and contact plate (11).

(1)-4 Armature Brake

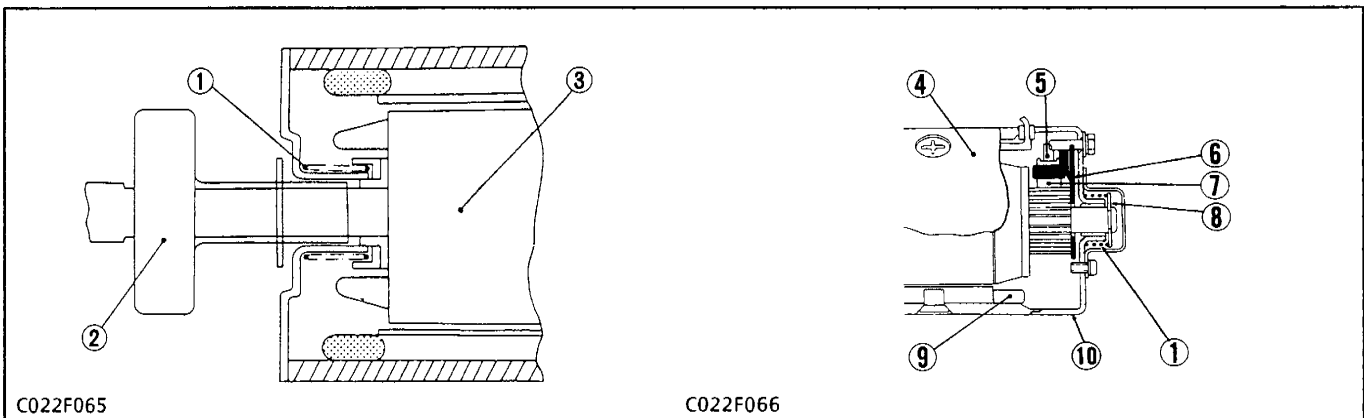

- | | | | |
|------------------------|------------------|----------------|----------------|
| (1) Brake Spring | (4) Yoke | (7) Brush | (10) End Frame |
| (2) Overrunning Clutch | (5) Brush Spring | (8) Washer | |
| (3) Armature | (6) Brush Holder | (9) Field Coil | |

The armature brake stops armature rotation immediately after the starter switch is turned off.

(1)-5 Operation of Starter

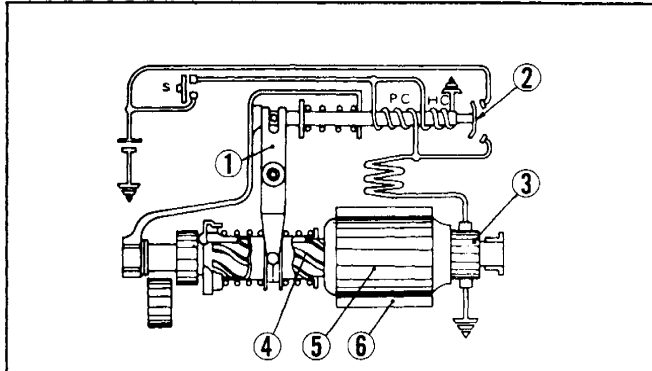

C022F068

■ When Main Switch Is Turned to Starting Position
 Current from the battery flows through the pull-in coil and holding coil, producing the magnetism in the windings to pull the plunger in.

At this time, the drive lever moves the pinion to engage with the ring gear.

- | | |
|-------------------|----------------------|
| (1) Drive Lever | (9) Ground |
| (2) Contact Plate | (10) Pinion |
| (3) Commutator | (11) Ring Gear |
| (4) Screw | (12) Spline Tube |
| (5) Armature | A: Operated by Lever |
| (6) Pole Core | PC: Pull-in Coil |
| (7) Return Spring | HC: Holding Coil |
| (8) Battery | S: Switch |

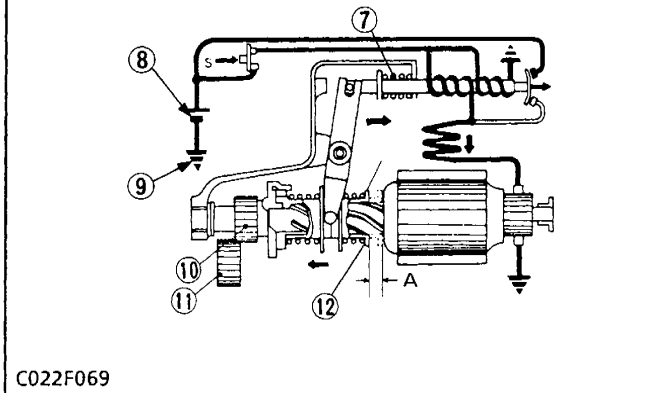

C022F069

■ When Contact Plate Is Closed

Large current flows through the motor section to operate the motor.

At this time, the pinion is moved forward by the screw for more contact.

Since the pull-in coil ends are short-circuited by the contact plate, the plunger is held only by the magnetism of the holding coil.

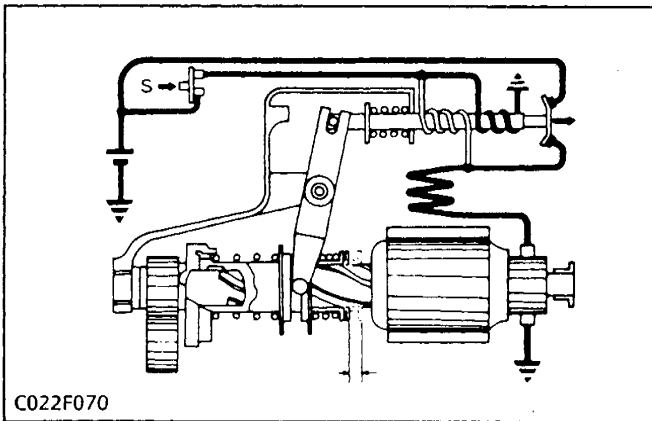

C022F070

■ When Main Switch Is Released

Current flows instantaneously through the pull-in coil in the opposite direction as shown in figure.

Therefore, the magnetic field is collapsed immediately.

As a result, the plunger is returned by the return spring. Simultaneously, the pinion is disengaged from the ring gear, the contact plate is disconnected, and the starter is immediately stopped by the armature brake.

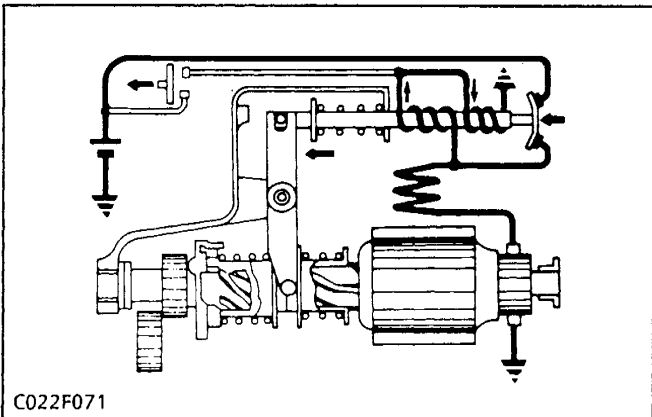

C022F071

(2) Starter

[B2150-B2150HST]

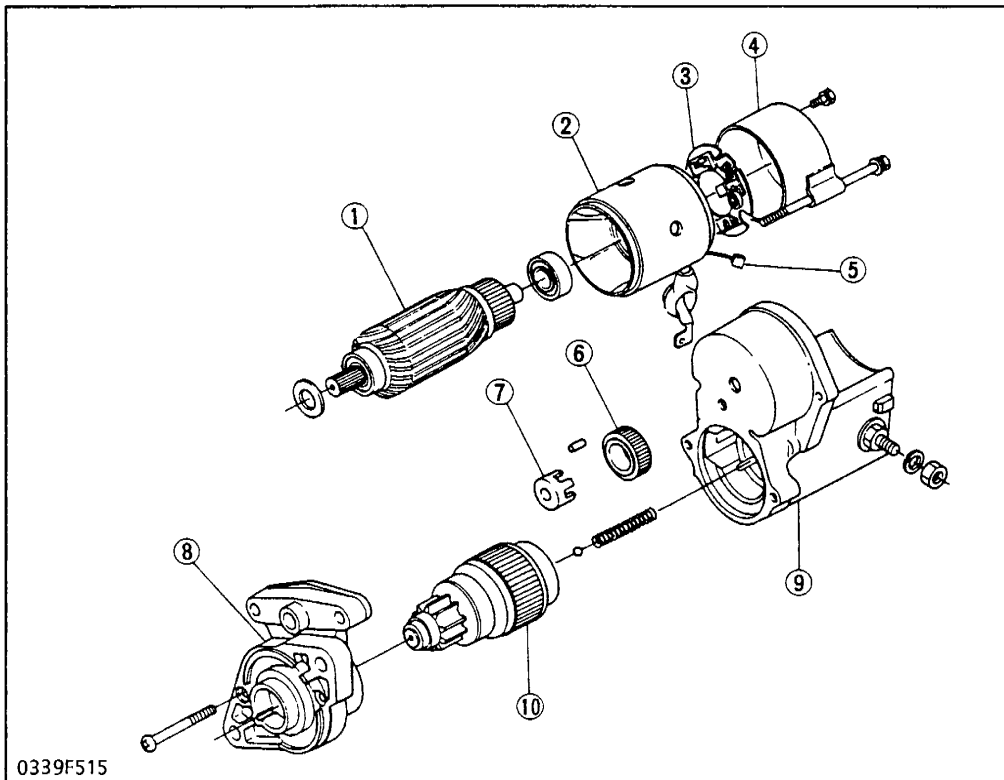

- (1) Armature
- (2) Yoke
- (3) Brush Holder
- (4) End Flame
- (5) Brush
- (6) Gear
- (7) Retainer
- (8) Housing
- (9) Magnetic Switch
- (10) Clutch

Type of Motor	DC, series winding, reduction type
Normal voltage	12 V
Normal output	1.0 kW
Time rating	30 seconds (Do not rotate continuously for)
Direction of rotation	Clockwise viewed from the pinion side
Number of pinion teeth	9

The starter for this engine is of the reduction type that has a small, high-speed motor.

The speed of the pinion gear is reduced to approx. one third of motor one.

(2)-1 Magnet Switch

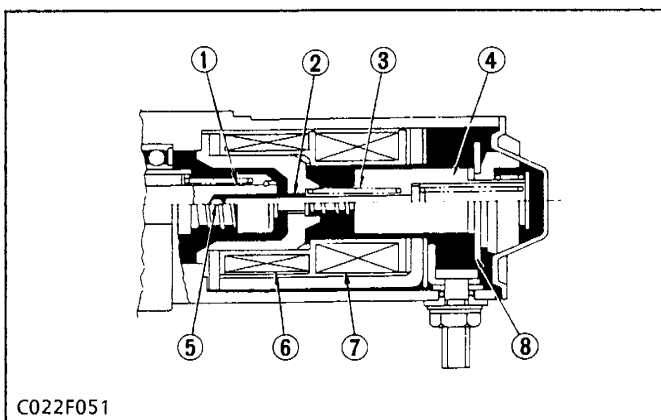

The plunger (4), contact plate (8) and plunger shaft (2) are made as one unit. When the key switch is turned to **START** position, the plunger is drawn in and thus clutch pinion shaft (1) is forced out. This meshes the pinion gear and the ring gear, and causes the contact plate to close the contacts, causing the main current to flow into the armature. When releasing the key switch, the plunger is returned to its former position by a return spring (3).

- (1) Clutch Pinion Shaft
- (2) Plunger Shaft
- (3) Return Spring
- (4) Plunger
- (5) Steel Ball
- (6) Holding Coil
- (7) Pull-in Coil
- (8) Contact Plate

(2)-2 Roller Clutch

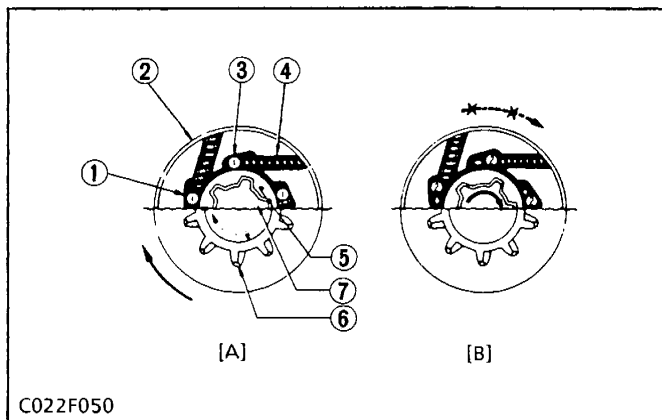

The roller clutch is so constructed that the power transmission relationship is automatically severed when the clutch pinion shaft (7) speed exceeds the clutch gear outer (2) speed at increased engine speeds. Therefore, the armature drives the ring gear and is never driven by the engine.

- [A] When power is transmitted
- [B] Idling rotation when clutch pinion shaft speed exceeds that of clutch gear outer

- (1) Locked Position
- (2) Clutch Gear Outer
- (3) Roller
- (4) Roller Spring
- (5) Spline Tube Inner
- (6) Pinion Gear
- (7) Clutch Pinion Shaft

(2)-3 Operation of Starter

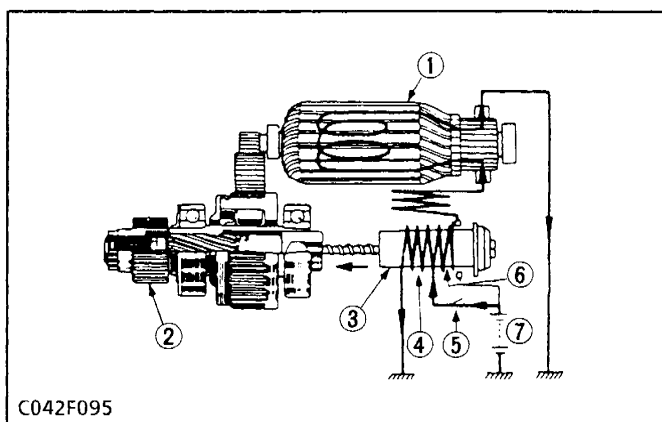

■ When Key Switch Is Turned to START Position

With the key switch (5) in the **START** position, current flows from the battery (7) to the holding coil (4), which moves the plunger (3) electromagnetically and pushes out the pinion gear (2). At the same time, current flowing through the pull-in coil (6) rotates the armature (1) at low speed.

- (1) Armature
- (2) Pinion Gear
- (3) Plunger
- (4) Holding Coil
- (5) Key Switch
- (6) Pull-in Coil
- (7) Battery

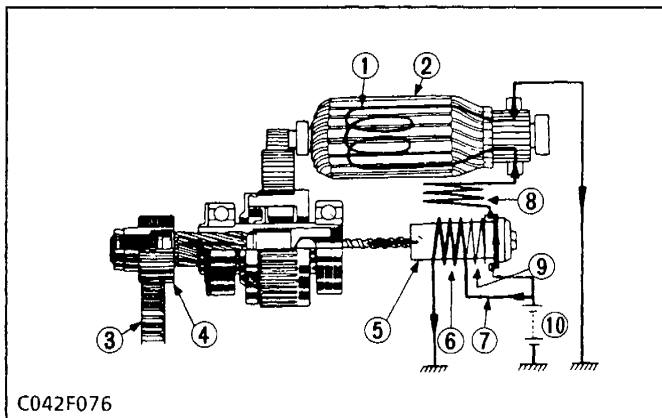

■ When Pinion Gear Meshes with Ring Gear

When the pinion gear (4) meshes with the ring gear (3) on the flywheel, current flows from the battery (10) directly into the field coil (8) and armature coil (1), but not through the pull-in coil (9). This rotates the armature (2) at a high speed, which in turn drives the ring gear through the pinion gear at 200 to 300 rpm.

- (1) Armature Coil
- (2) Armature
- (3) Ring Gear
- (4) Pinion Gear
- (5) Plunger
- (6) Holding Coil
- (7) Key Switch
- (8) Field Coil
- (9) Pull-in Coil
- (10) Battery

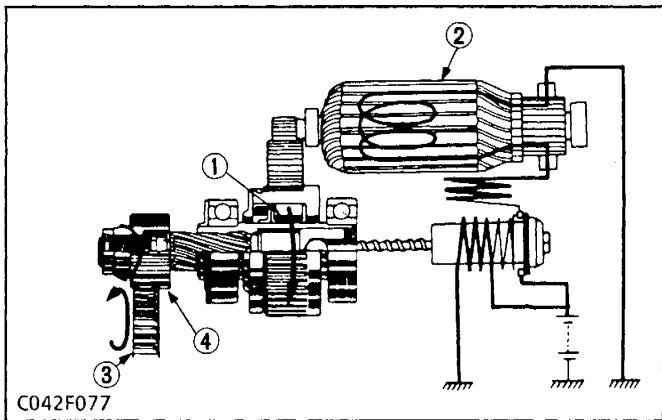

■ When Engine Is Running

When the engine starts and drives the pinion gear (4) with the ring gear (3), the roller clutch (1) disengages to prevent an armature (2) from being driven by the engine.

- (1) Roller Clutch
- (2) Armature
- (3) Ring Gear
- (4) Pinion Gear

[B2150-B2150HST](Continued)

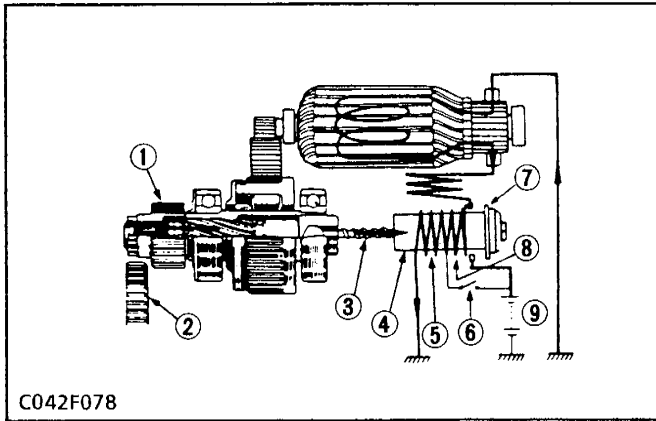

C042F078

■ When Releasing Key Switch

When releasing the key switch (6), it returns from START to ON position and the starter circuit opens. Then, current flows from the battery (9) to the pull-in coil (8) and the holding coil (5) through the contact plate (7). Since the magnetic force is generated in each coil in the opposite direction, the magnetic field collapses and the plunger (4) is returned to its former position by a return spring (3). This opens the contacts on the contact plate (7) and separates pinion gear (1) from ring gear (2), whereupon the pinion gear stops rotating.

- | | |
|-------------------|-------------------|
| (1) Pinion Gear | (6) Key Switch |
| (2) Ring Gear | (7) Contact Plate |
| (3) Return Spring | (8) Pull-in Coil |
| (4) Plunger | (9) Battery |
| (5) Holding Coil | |

(3) Glow Plug

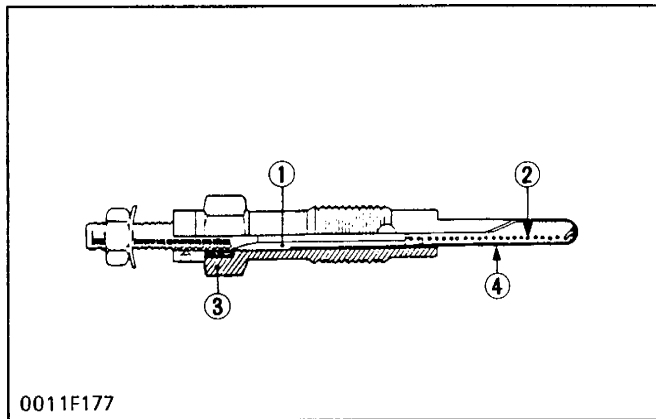

0011F177

The glow plugs are used for each pre-combustion chamber of the cylinder head to make starting easier. The glow plugs are of the quick-heating type, which makes starting easier with short preheating time.

- | | |
|-----------------------|----------------|
| (1) Insulating Powder | (3) Housing |
| (2) Heat Coil | (4) Metal Tube |

(4) Safety Switch

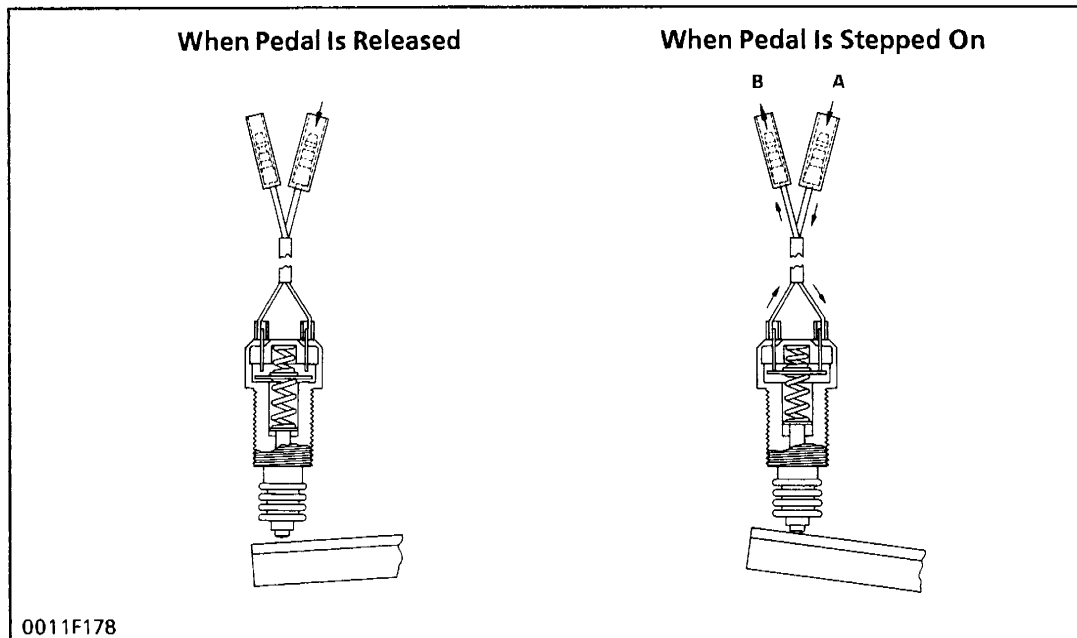

0011F178

- A: From Main Switch
B: To Starter

The safety switch prevents current from flowing to the starter when the clutch pedal is not depressed. This is to ensure safe starting.

[3] ENGINE KEY SWITCH SHUT-OFF SYSTEM

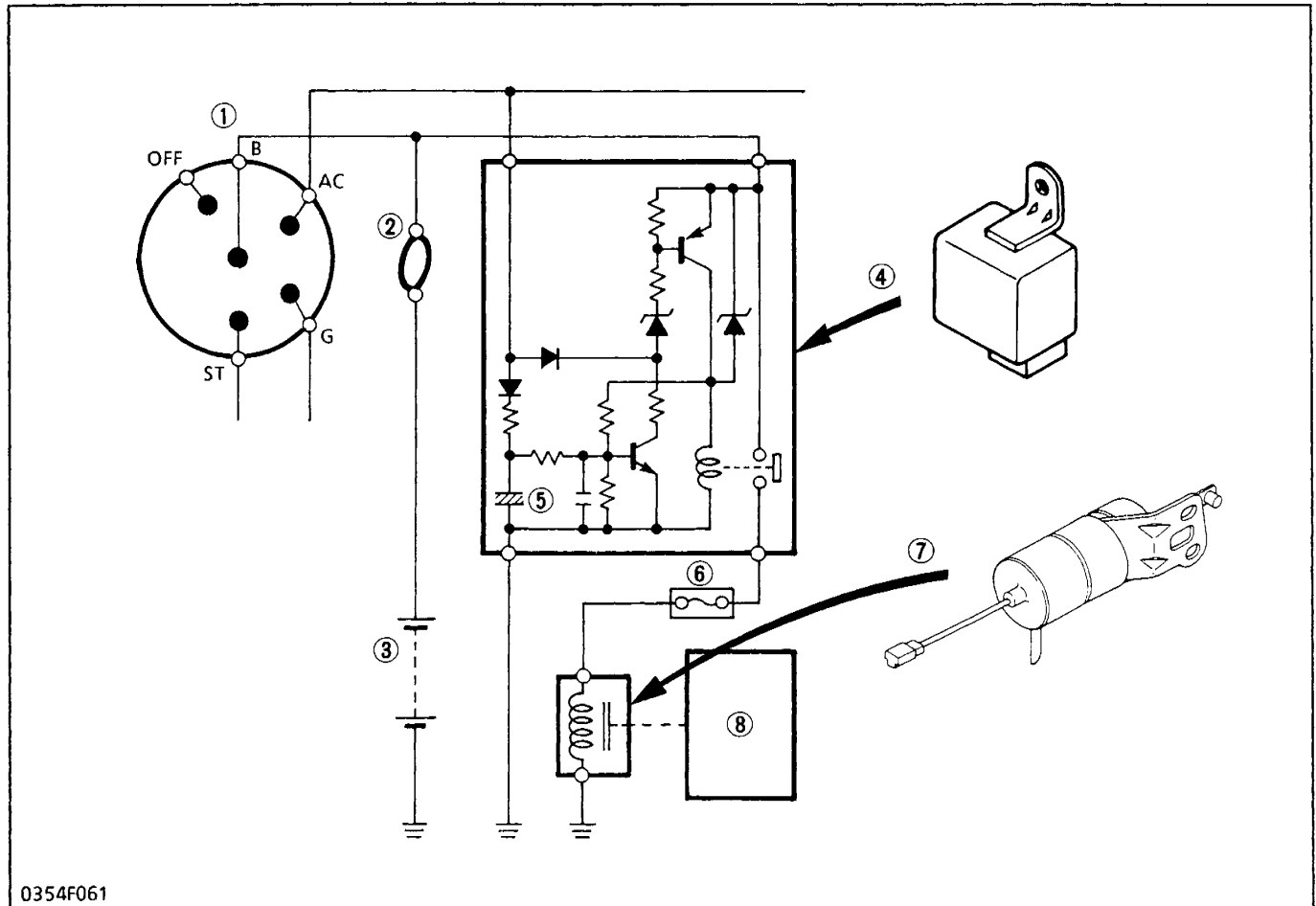

0354F061

- | | | | |
|------------------|-----------------|---------------|---------------------------|
| (1) Main Switch | (3) Battery | (5) Capacitor | (7) Fuel Cut Off Solenoid |
| (2) Fusible Link | (4) Timer Relay | (6) Fuse | (8) Fuel Injection Pump |

On the engine key switch shut-off system, turning the main switch from the **ON** position to the **OFF** position moves the fuel injection pump control rack to the "No Fuel Injection" position through the fuel cut off solenoid and the same linkage as when the stop lever is operated by manual operation.

As soon as the main switch (1) is turned to the **OFF** position, the capacitor starts discharging and

continues it for approx. 10 seconds. During the discharging period, the current flows as follows:

Battery (3) → Main Switch (1) → Timer Relay (4) → Fuel Cut Off Solenoid (7) → Ground.

Then, the engine stops.

After 10 seconds, the relay contact point in the timer open to prevent the battery from over-discharging.

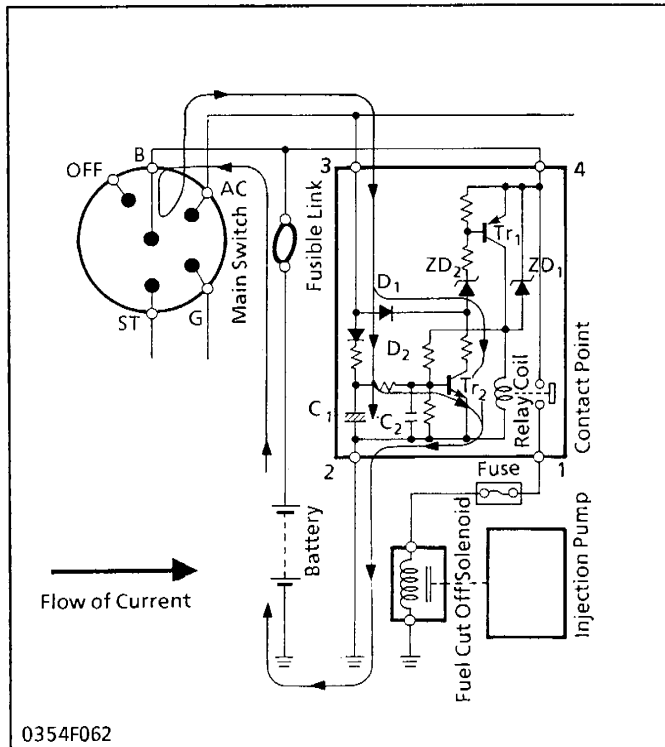
(1) Operation of Timer Relay**■ When the Main Switch is Turned to "ON" Position**

The capacitor C1 is charged by the battery current flowing through the terminal 3 immediately after the main switch is turned to the ON position.

1. The transistor Tr2 is then turned on.
2. The transistor Tr1 remains off because the battery voltage is applied to the anode of the zener diode ZD2.
3. Therefore, the relay coil does not conduct, and the relay contact points remain open so that the battery current does not flow into the fuel cut off solenoid.

(Reference)

- The critical voltage of zener diode ZD2 is about 5 volts.

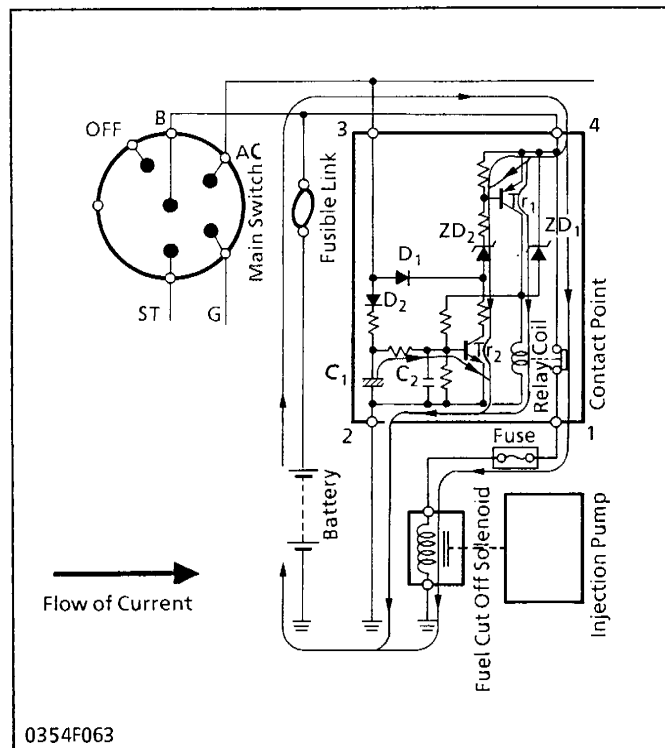
**■ When the Main Switch is Turned to "OFF" Position**

Changes described below take place in the timer to stop the engine when the main switch is turned to the OFF position.

1. The battery voltage is not applied to the terminal 3.
2. Since the discharge current from capacitor C1 flows into the base of transistor Tr2, it is held ON state.
3. The voltage at the anode of the zener diode ZD2 becomes low, and the voltage across the zener diode ZD2 exceeds the critical voltage so that this zener diode conducts.
4. Consequently, the battery current supplied from the terminal 4 begins to flow from the collector to the emitter of the relay drive transistor Tr1.
5. The transistor Tr1 is then turned on, and the battery current flows into the relay coil to close relay contact point.
6. The battery current flows into the fuel cut off solenoid via the terminals 4 and 1.
7. As a result, the amount of the fuel injected from the injection pump becomes zero to stop the engine.
8. The transistor Tr2 turns off after the discharging period approx. 10 seconds of the capacitor C1. No current flows through the circuit, and then the relay contact point opens so that the battery current does not flow into the fuel cut off solenoid.

(2) Fuel Cut Off Solenoid

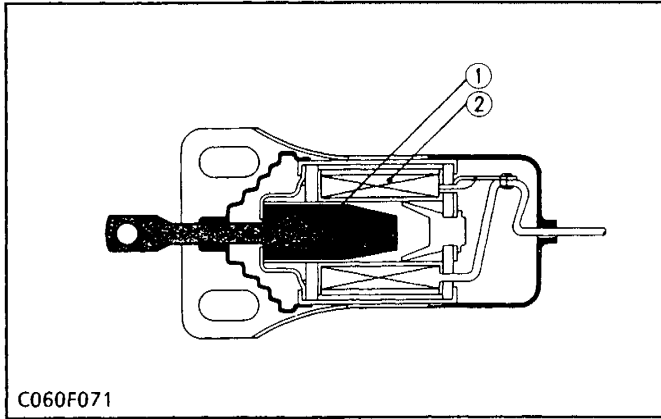

Flowing of the battery current into the coil (2) while the timer relay contact point is closed attracts the plunger (1) to actuate the stop lever of the injection pump. When the battery current stops, the plunger is returned to the original position by the spring.

(1) Plunger

(2) Coil

[4] CHARGING SYSTEM

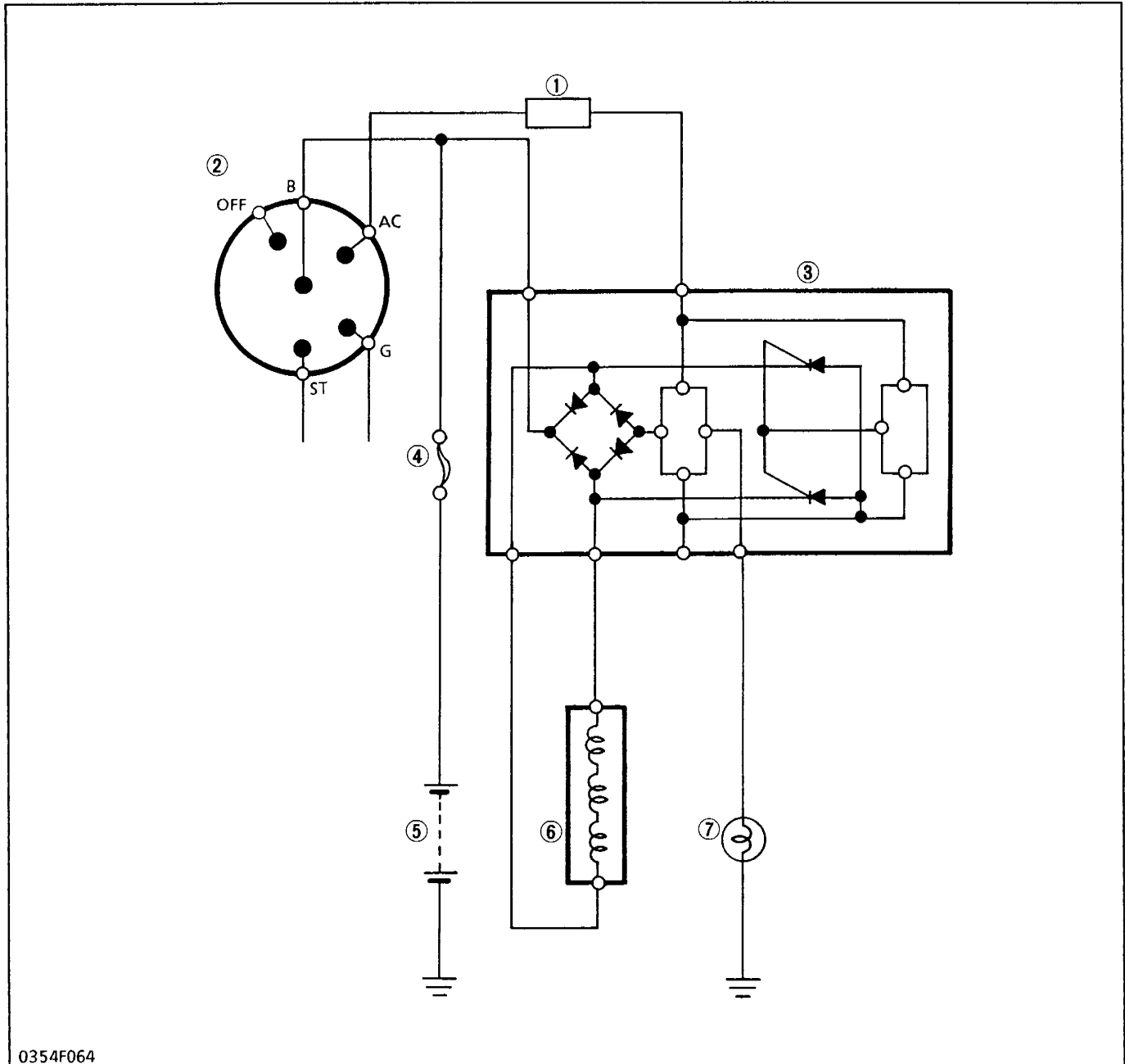

0354F064

- (1) Fuse Holder
- (2) Main switch
- (3) Regulator
- (4) Fusible Link
- (5) Battery
- (6) AC Dynamo
- (7) Charge Lamp

The charging system supplies electric power for various electrical devices and also charges the battery while the engine runs.
It consists of an AC dynamo and a regulator.

- **NOTE**
- The charge system for Canada is shown in the last pages in "MECHANISM".

(1) AC Dynamo

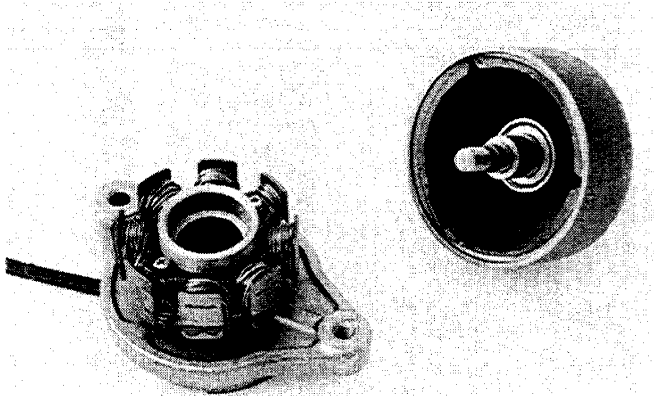

0302P005

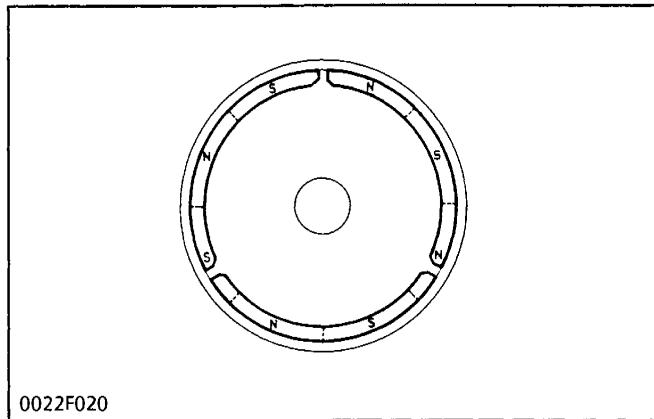

0022F020

This dynamo is an 8-8 pole rotating magnet type generator. It is simple in construction, consisting of a stator and rotor. The rotor is made up of eight permanent magnet pole pieces assembled on a shaft and rotates on the center of the stator around which eight electromagnetic coils are provided for.

This dynamo produces higher voltage in slow speed rotation, and charges electric current to the battery during engine idling.

(2) Regulator

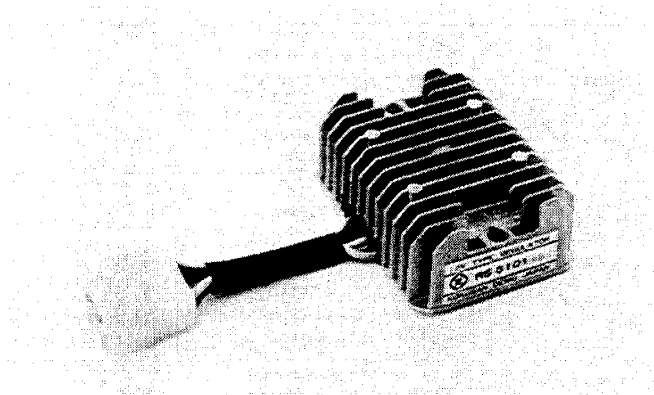

0302P006

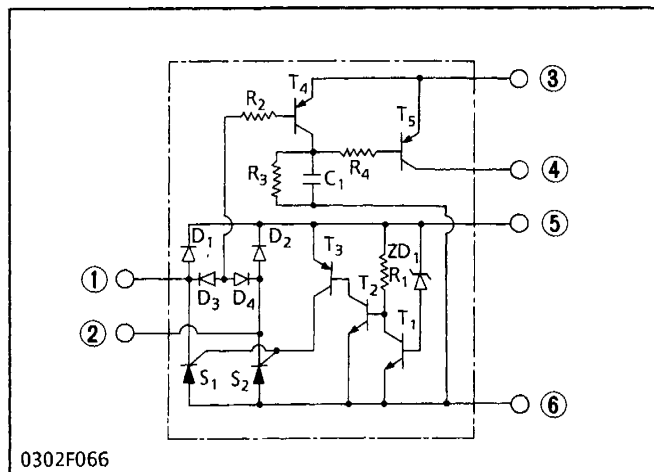

0302F066

A regulator has two functions:

1. When the battery voltage is low, it turns the SCR on to form a charging circuit to the battery.
2. During charging, it turns the charging lamp off.

- (1) Light Blue (AC Dynamo)
- (2) Light Blue (AC Dynamo)
- (3) Yellow (Main Switch Terminal AC)
- (4) Green (Charge Lamp)
- (5) Red (Main Switch Terminal No.30)
- (6) Black (Ground)

- C1: Capacitor
- D1: Diode
- D2: Diode
- D3: Diode
- D4: Diode
- R1: Resistor
- R2: Resistor
- R3: Resistor
- R4: Resistor
- S1: SCR (Silicon Controlled Rectifier)
- S2: SCR (Silicon Controlled Rectifier)
- T1: Transistor
- T2: Transistor
- T3: Transistor
- T4: Transistor
- T5: Transistor
- ZD1: Zener Diode

(3) Operation of Charging System

(3)-1 When Main Switch Is Turned "● (ON)"

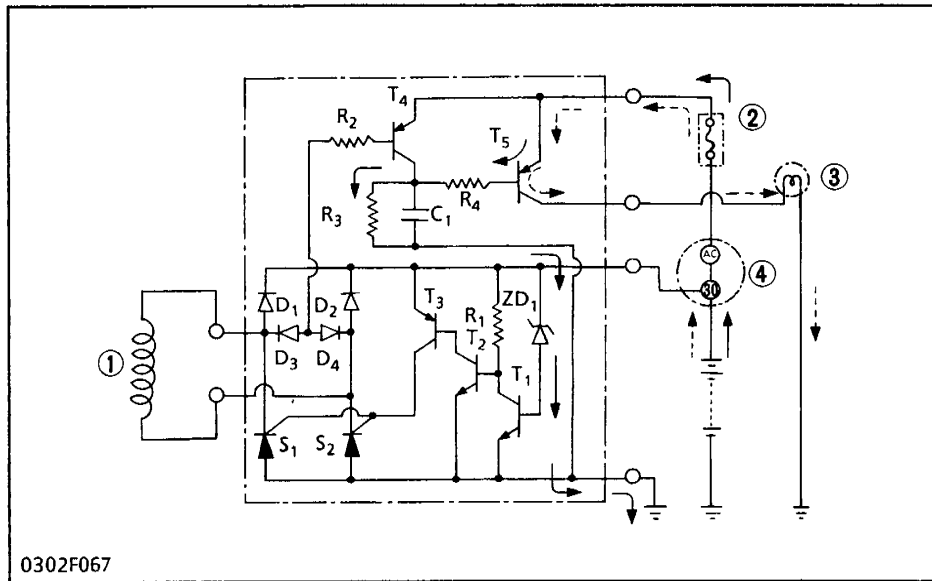

- (1) AC Dynamo
- (2) Fuse Holder
- (3) Battery Charge Lamp
- (4) Main Switch
- C1: Capacitor
- D1: Diode
- D2: Diode
- D3: Diode
- D4: Diode
- R1: Resistor
- R2: Resistor
- R3: Resistor
- R4: Resistor
- S1: SCR (Silicon Controlled Rectifier)
- S2: SCR (Silicon Controlled Rectifier)
- T1: Transistor
- T2: Transistor
- T3: Transistor
- T4: Transistor
- T5: Transistor
- ZD1: Zener Diode

When the main switch is turned on, the current (→) flows from the base of the transistor T5 to the resistor R4, resistor R3 and ground, turning the transistor T5 on. Then, the current (→) flows to the charge lamp to light.

(3)-2 When Engine Starts

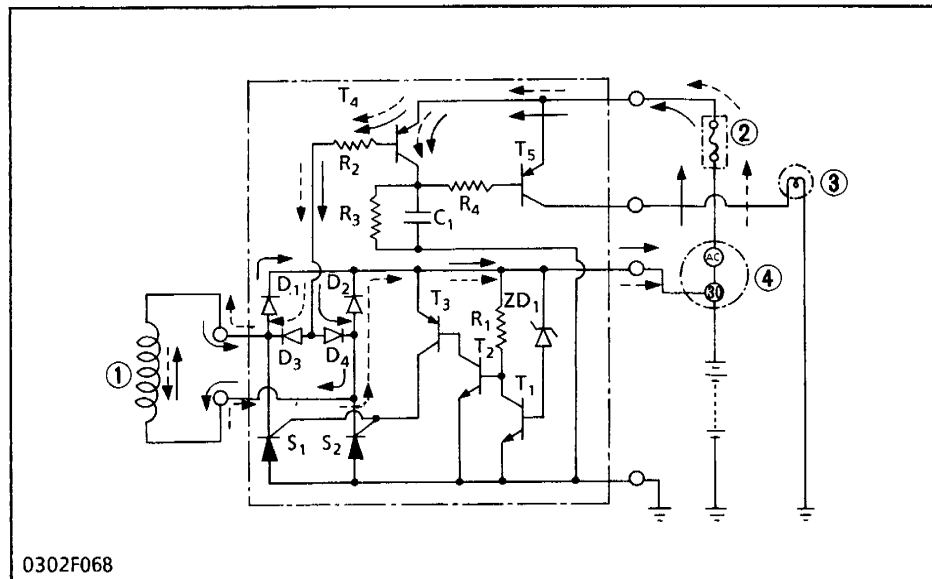

- (1) AC Dynamo
- (2) Fuse Holder
- (3) Battery Charge Lamp
- (4) Main Switch
- C1: Capacitor
- D1: Diode
- D2: Diode
- D3: Diode
- D4: Diode
- R1: Resistor
- R2: Resistor
- R3: Resistor
- R4: Resistor
- S1: SCR (Silicon Controlled Rectifier)
- S2: SCR (Silicon Controlled Rectifier)
- T1: Transistor
- T2: Transistor
- T3: Transistor
- T4: Transistor
- T5: Transistor
- ZD1: Zener Diode

When the engine starts and a generated voltage in the dynamo causes a current in ↑ direction, the current flows as follows:

Diode D1 → Main Switch → Transistor T4 → Resistor R2 → Diode D4 → Dynamo

With the current in ↓ direction, the current flows as follows:

Diode D2 → Main Switch → Transistor T4 → Resistor R2 → Diode D3 → Dynamo

In both cases, the current flows to the base of the transistor T4 to turn T4 on.

When the transistor T4 is turned on, potential difference between the emitter and base of the transistor T5 becomes zero, turning T5 off. The charge lamp, then, goes off.

A capacitor C1 is provided to stabilize voltage across the resistor R3. Without this capacitor, the transistor T4 repeats on and off at a low voltage in the dynamo, and the charge lamp lights dimly.

This capacitor eliminates the ripples to prevent unstable operation.

(3)-3 During Charging

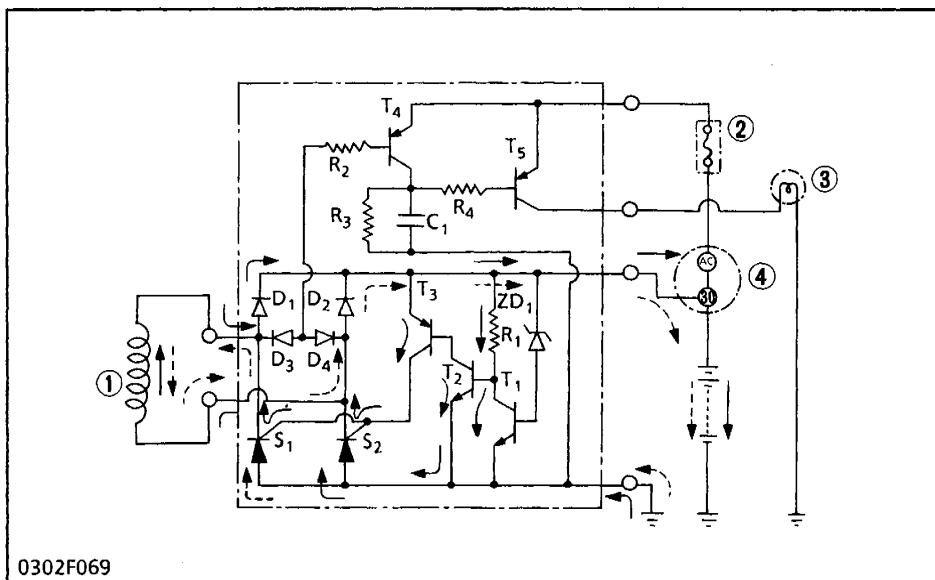

- (1) AC Dynamo
- (2) Fuse Holder
- (3) Battery Charge Lamp
- (4) Main Switch
- C1: Capacitor
- D1: Diode
- D2: Diode
- D3: Diode
- D4: Diode
- R1: Resistor
- R2: Resistor
- R3: Resistor
- R4: Resistor
- S1: SCR (Silicon Controlled Rectifier)
- S2: SCR (Silicon Controlled Rectifier)
- T1: Transistor
- T2: Transistor
- T3: Transistor
- T4: Transistor
- T5: Transistor
- ZD1: Zener Diode

When the battery voltage is below the specified value (14.5 ± 0.5 V) of the zener diode ZD1, a current does not flow to zener diode ZD1.

Base current of the transistor T1 does not flow, and the transistor T3 is off.

The current flows from the resistor R1 to the base of the transistor T2 to turn it on.

When the transistor T2 is on, the transistor T3 is forward-biased and turns on, allowing a gate current of the SCRs S1 and S2 to turn them on.

Therefore, when a generated voltage in the dynamo causes a current in \uparrow direction, the charging current flows as follows:

Diode D1 \rightarrow Main Switch (Terminal No.30) \rightarrow Battery \rightarrow Ground \rightarrow SCR S2 \rightarrow Dynamo.

With the current in \downarrow direction, the charging current flows as follows:

Diode D2 \rightarrow Main Switch (Terminal No.30) \rightarrow Battery \rightarrow Ground \rightarrow SCR S1 \rightarrow Dynamo

(3)-4 Overcharging Prevention

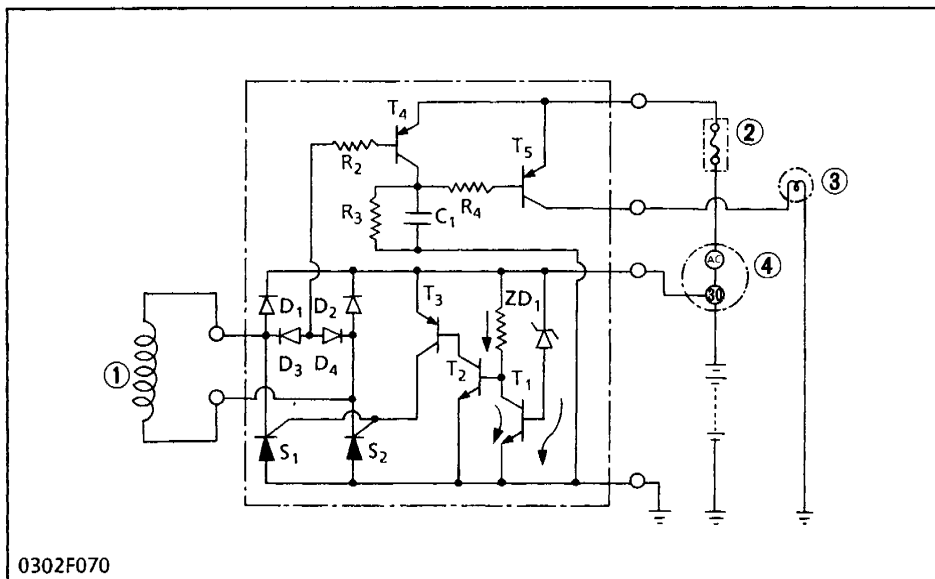

- (1) AC Dynamo
- (2) Fuse Holder
- (3) Battery Charge Lamp
- (4) Main Switch
- C1: Capacitor
- D1: Diode
- D2: Diode
- D3: Diode
- D4: Diode
- R1: Resistor
- R2: Resistor
- R3: Resistor
- R4: Resistor
- S1: SCR (Silicon Controlled Rectifier)
- S2: SCR (Silicon Controlled Rectifier)
- T1: Transistor
- T2: Transistor
- T3: Transistor
- T4: Transistor
- T5: Transistor
- ZD1: Zener Diode

When the battery voltage rises over the specified value of the zener diode ZD1, a current flows to the base of the transistor T1 through the ZD1, turning the transistor T1 on. This causes potential difference between the base and emitter of the transistor T2 to become zero, turning off the transistor T2 simultaneously.

Therefore, the current is no longer supplied to the gates of the SCRs S1 and S2, turning off the SCRs and the charging circuit is cut off.

[5] LIGHTING SYSTEM

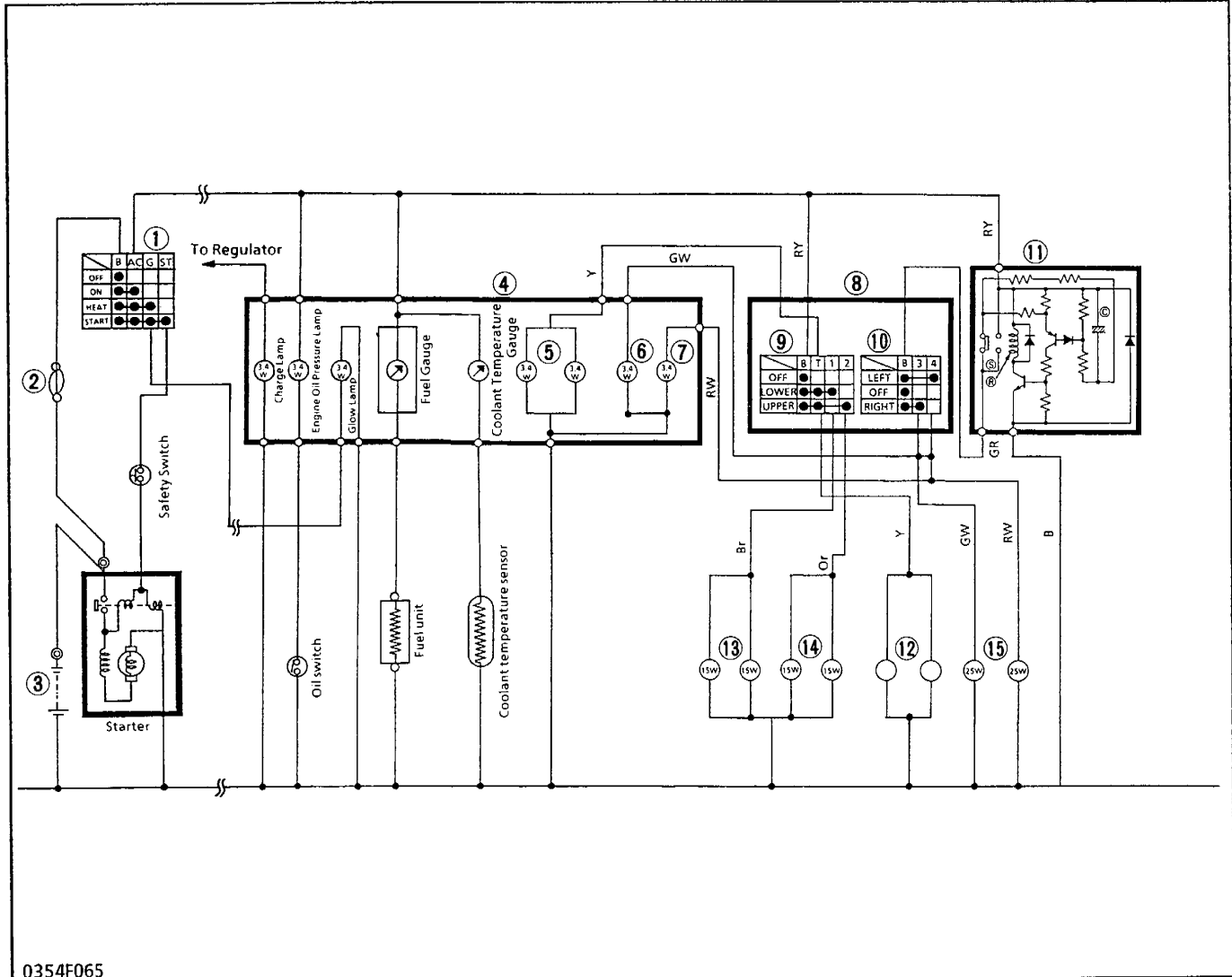

0354F065

- | | | | |
|------------------|------------------------------------|--------------------|----------------------------|
| (1) Main Switch | (5) Panel Board Illumination Lamps | (9) Light Switch | (13) Head Lights LOW-beam |
| (2) Fusible Link | (6) L.H. Pilot Lamp | (10) Hazard Switch | (14) Head Lights HIGH-beam |
| (3) Battery | (7) R.H. Pilot Lamp | (11) Hazard Unit | (15) Hazard Lights |
| (4) Panel Board | (8) Combination Switch | (12) Tail Lights | |

The lighting system consists of combination switch (light switch and hazard switch), head lights, tail light, panel board illumination, hazard unit, hazard lights, pilot lamps, etc.

(1) Head Light

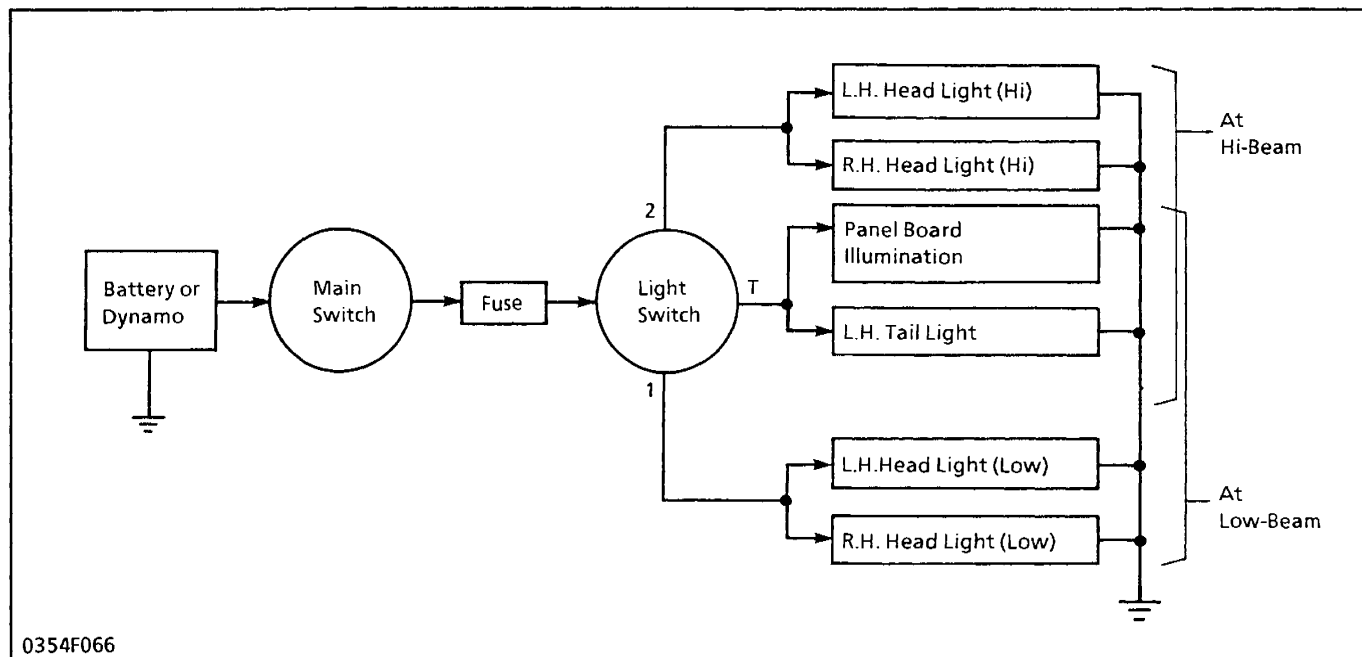

The light switch, which forms a combination switch with the hazard switch, has three position; **OFF, LOW-BEAM** and **HIGH-BEAM**.

Current passes through the light circuit as shown in the figure above.

(2) Hazard Light

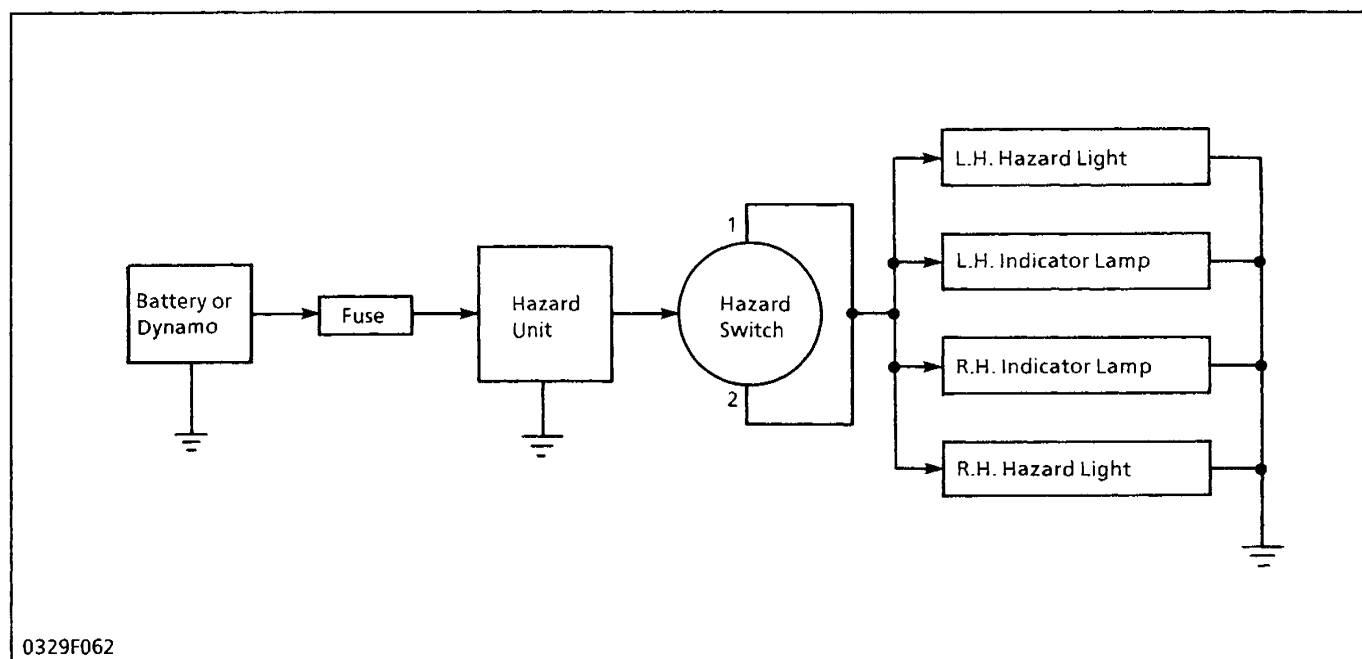

The hazard switch, which forms a combination switch with the light switch, has three positions; **OFF, 1** and **2**. At either switch lever position of 1 or 2,

current flows to the same circuit, blinking the hazard lights and indicator lamps as shown in the figure above.

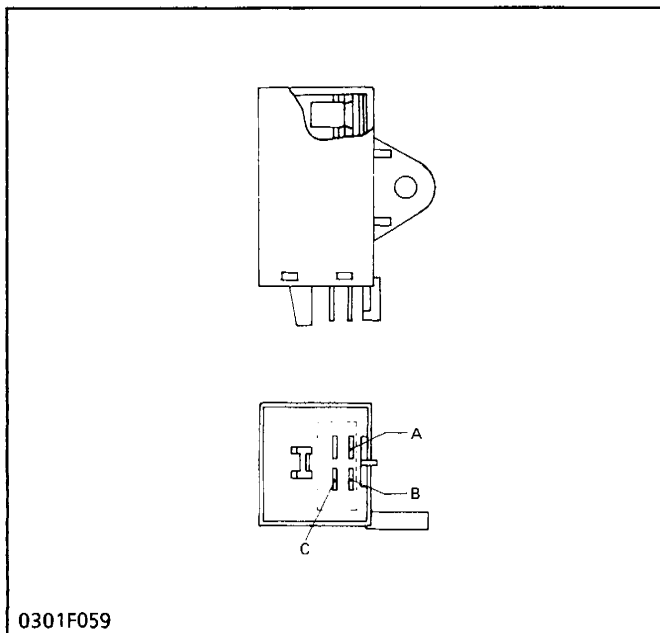

When the hazard light switch is turned on, power from the battery enters the terminal "A" of the hazard unit. The hazard unit consists of a capacitor, transistors, diodes, resistors and other parts.

The intermittent current, controlled by the hazard unit, is transmitted from the terminal "C" to the hazard lights.

0301F059

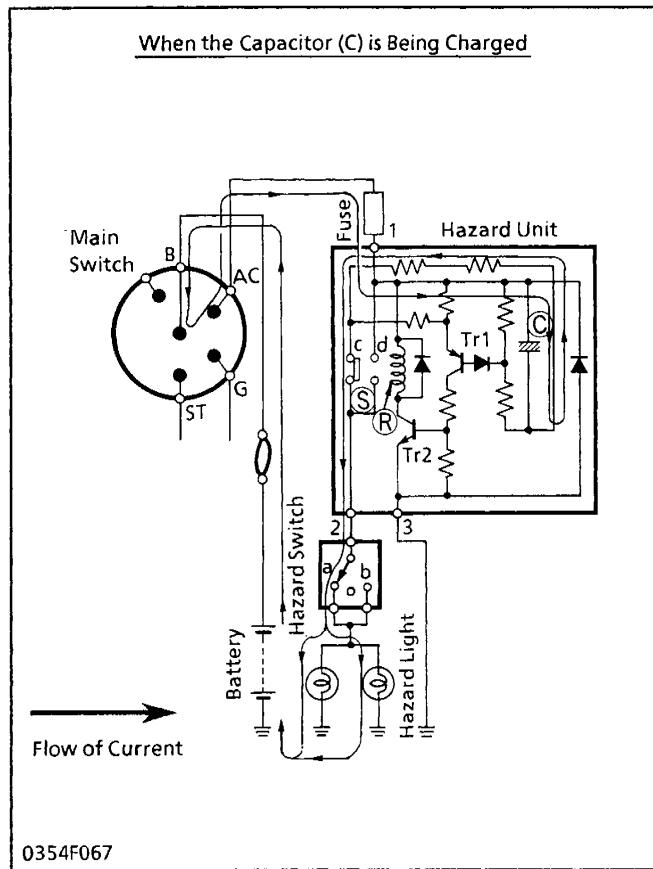

■ Hazard Unit

The hazard unit, consisting of a capacitor, transistors, diodes, resistors and the other parts, sends intermittent current to the hazard lights. Intermittent current is generated in the following sequence.

1. Contact S contacts with the terminal c by the spring tension and there is no potential difference (0 V) across capacitor C.
 2. When the hazard switch is set at a or b, the charging current to capacitor C passes through contact S and the hazard switch, and flows into the hazard light. Since the current is small, at this time, the hazard light does not light.
 3. As capacitor C is charged more, current flows from the emitter of transistor Tr1 to the base, turning it on.
 4. Transistor Tr2 is then turned on, and large current from the battery flows through the coil R, causing coil R to pull contact S to terminal d.
 5. The large current from the battery then passes through terminal 1, terminal 2 and the hazard switch to light the hazard light.
 6. While contact S is pulled at terminal d, capacitor C is not charged so that voltages across capacitor C become equal, which in turn switches transistor Tr1 off.
 7. Then, transistor Tr2 is turned off, current is no longer supplied to coil R, and contact S returns to terminal c.
 8. The condition described in step 1 above is restored. As long as the hazard switch is set at a or b, intermittent current continues to flow in the circuit.
- The flash rate is approx. 67 to 83 cycle per minute.

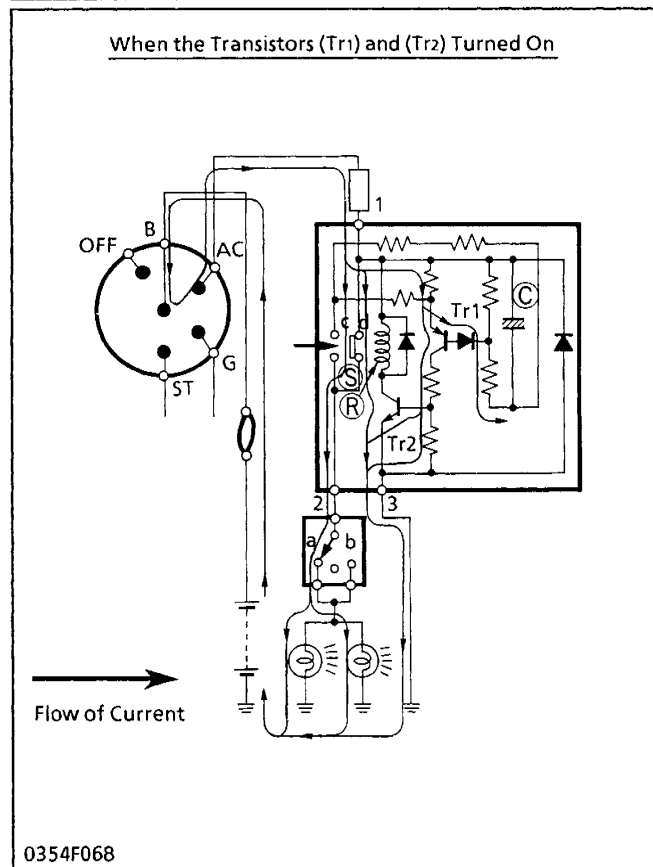

[6] EASY CHECKER

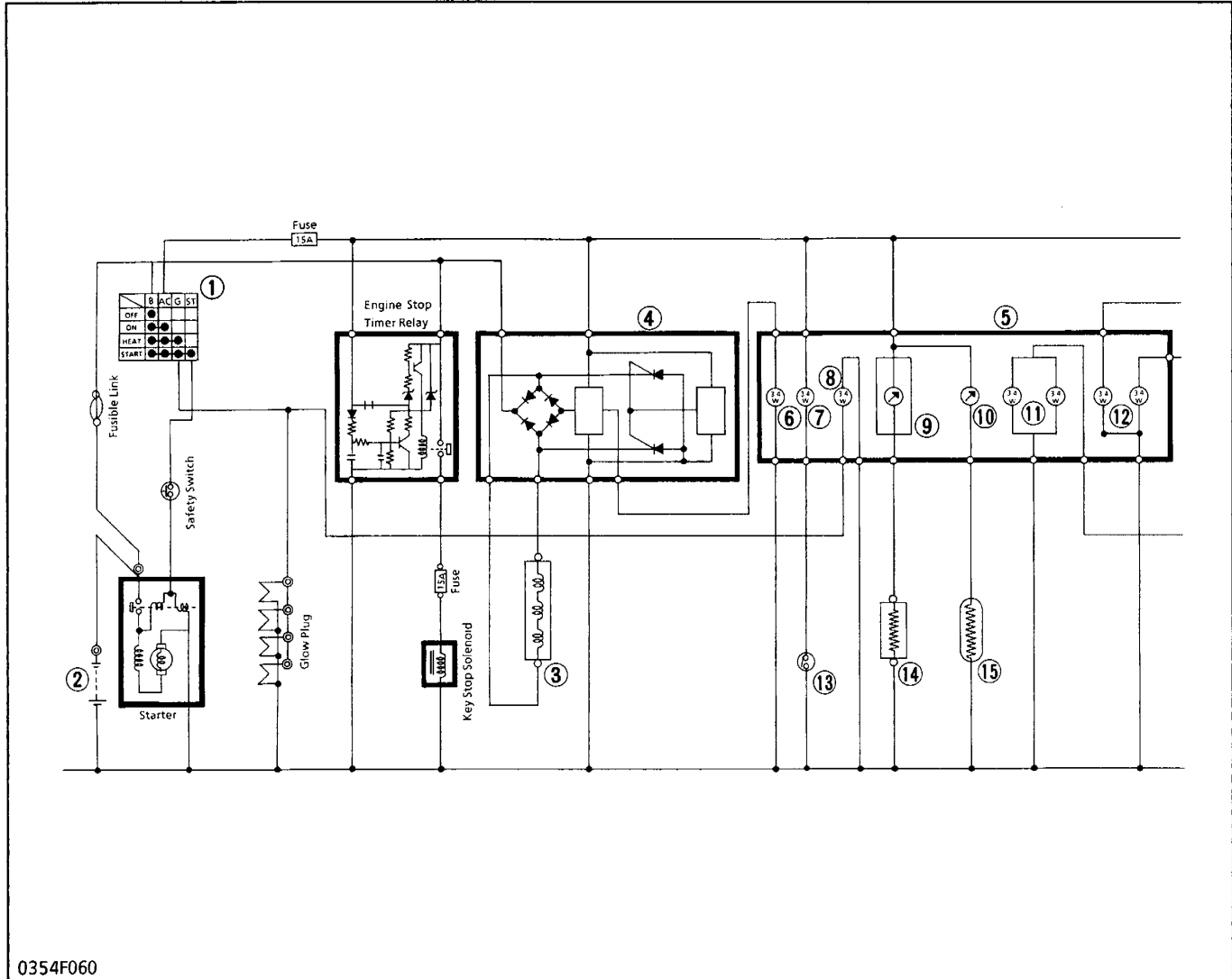

0354F060

- | | | | |
|-----------------|------------------------------|--------------------------------|---------------------------------|
| (1) Main Switch | (5) Easy Checker Board | (9) Fuel Gauge | (13) Engine Oil Pressure Switch |
| (2) Battery | (6) Charge Lamp | (10) Coolant Temperature Gauge | (14) Fuel Unit |
| (3) Dynamo | (7) Engine Oil Pressure Lamp | (11) Illumination Lamps | (15) Coolant Temperature Sensor |
| (4) Regulator | (8) Glow Lamp | (12) Pilot Lamps | |



To check the conditions of tractor easily before and during operation, easy checker combination of lamps on the easy checker board is provided.

Easy checker gives following three checks.

- Charge circuit
- Engine oil pressure
- Glow plug indicator

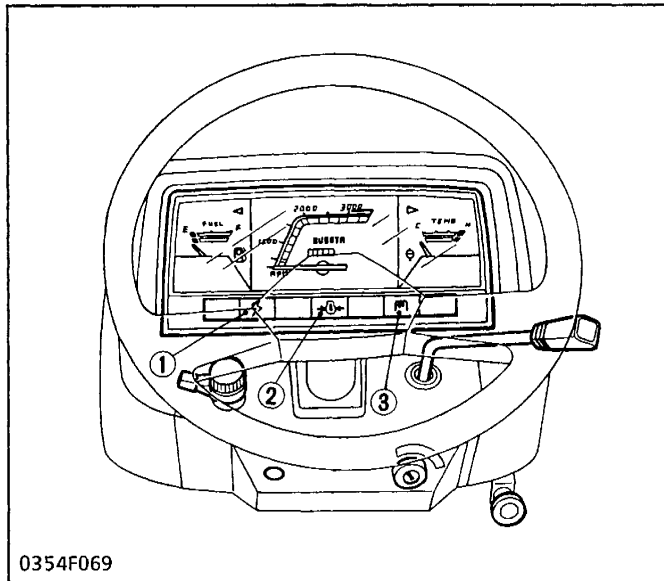
(1) Indication Items



1.  **Improper charging**
Lights up when the charging is improper.
2.  **Low engine oil pressure**
Lights up when the engine oil pressure drops below approx. 49 kPa (0.5 kgf/cm², 7.1 psi).
3.  **Glow lamp (Pre-heating Indicator)**
When the key switch is in the "Preheat" position, the glow lamp illuminates.

(2) Low Engine Oil Pressure

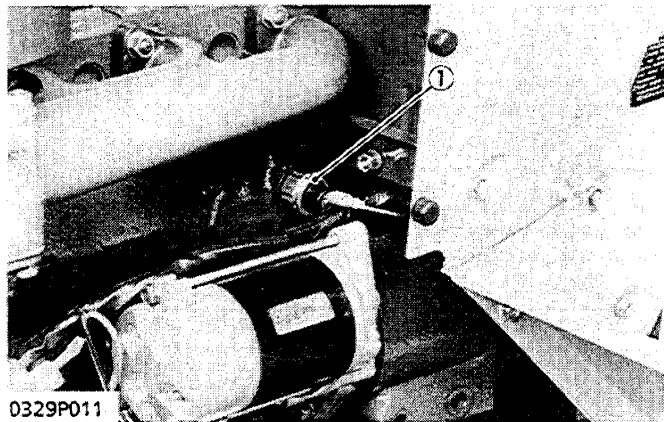

Low engine oil pressure is detected by the oil switch installed in the lubricating system of engine.

(1) Oil Pressure Switch

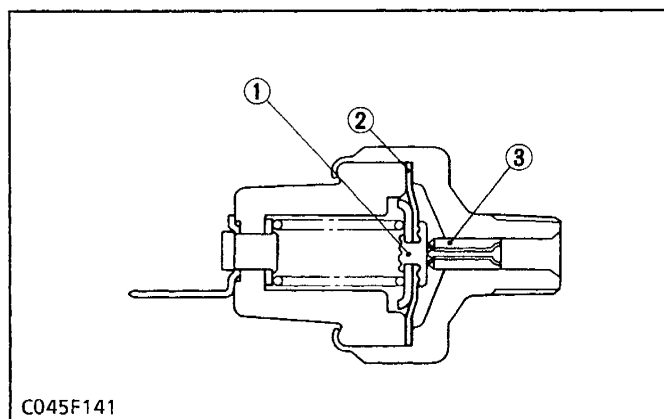

(1) Terminal Contact (3) Body Contact
(2) Diaphragm

■ Oil Pressure Switch

While oil pressure is high and the force applied to the diaphragm (2) is larger than the spring tension, the terminal contact (1) is open separated from the body contact (3). If the pressure drops below approx. 49 kPa (0.5 kgf/cm², 7.1 psi), the contact closes.

[7] GAUGE

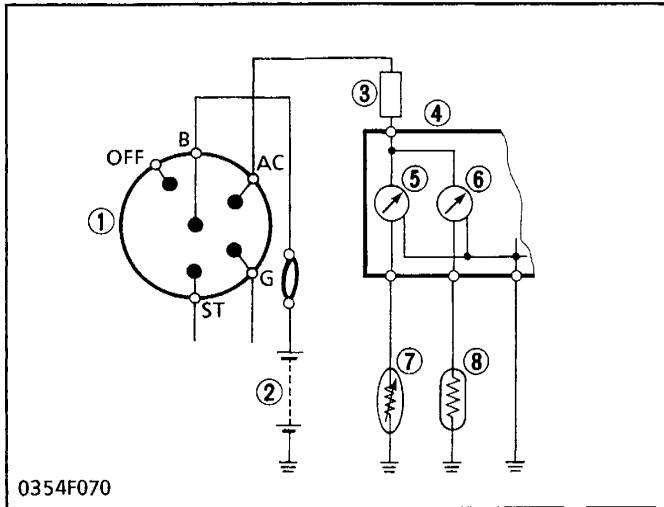

- (1) Main Switch
- (2) Battery
- (3) Fuse
- (4) Panel Board
- (5) Fuel Gauge
- (6) Coolant Temperature Gauge
- (7) Fuel Level Sensor
- (8) Coolant Temperature Sensor

The fuel quantity and coolant temperature are indicated by the ammeters. The ammeters indicate each amperate flowing through the fuel level sensor (7) for the fuel quantity detection and through the coolant temperature sensor (8) for the coolant temperature detection.

(1) Fuel Quantity

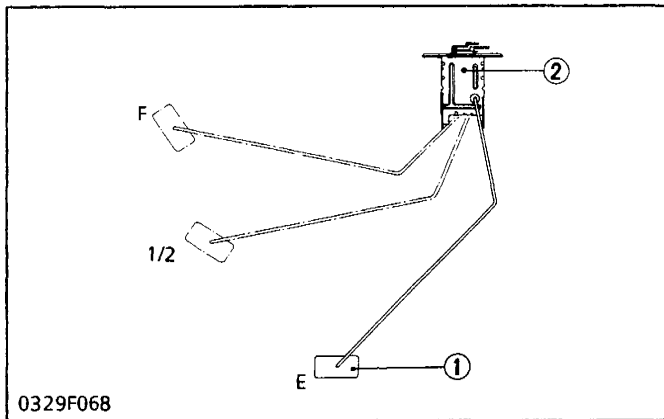

- (1) Float
- (2) Variable Resistor

■ Fuel Level Sensor

The remaining fuel quantity is detected by the fuel level sensor installed in the fuel tank and indicated on the fuel gauge. For detection, a float and a resistor are used.

As the float (1) lowers, the resistance of the variable resistor (2) varies. The relation between the amount of fuel and the resistance is as follows.

F	1/2	E (Remaining fuel of approx. 2.0 ℓ, 0.53 U.S. gal, 0.44 imp.gal)
1 to 5 Ω	28.5 to 36.5 Ω	103 to 117 Ω

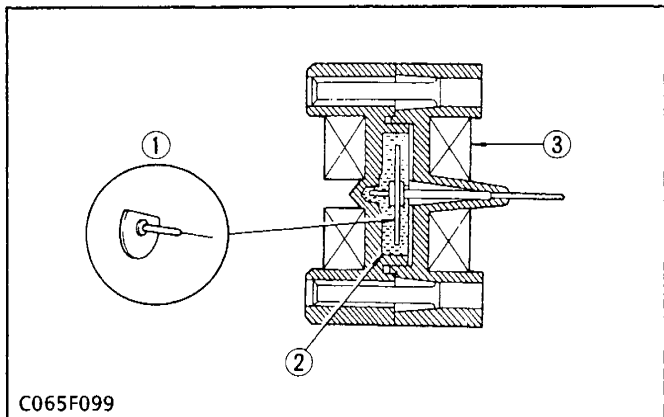

- (1) Rotor (Magnet)
- (2) Silicone Oil
- (3) Coil

■ Fuel Gauge

The gauge has a rotor (magnet) (1) and the shunt windings which cross the rotor with one another to generate magnetic field.

The magnetic field generated by the windings moves the rotor. The rotor is immersed in silicone oil (2) to regulate the rotation of the rotor.

As the rotor is disc type and symmetrical, the pointer stays where it was even when the main switch is turned off.

After filling up the tank and turning the main switch on, it will take about two minutes before the pointer comes to stop.

(2) Coolant Temperature

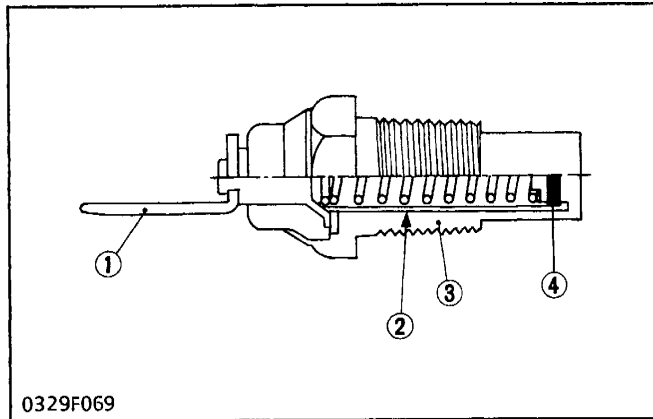

0329F069

- (1) Terminal
- (2) Insulator
- (3) Body
- (4) Thermistor

■ Coolant Temperature Sensor

The coolant temperature sensor is installed to the cylinder head of engine, and its tip is in touch with the coolant. It contains a thermistor (4) whose electrical resistance decreases as the temperature increases.

Current varies with changes in the coolant temperature, and the increases or decreases in the current move the pointer of gauge.

Characteristics of Thermistor	
Temperature	Resistance
50°C (122°F)	153.9 Ω
80°C (176°F)	51.9 Ω
105°C (221°F)	23.6 Ω
130°C (266°F)	12.2 Ω

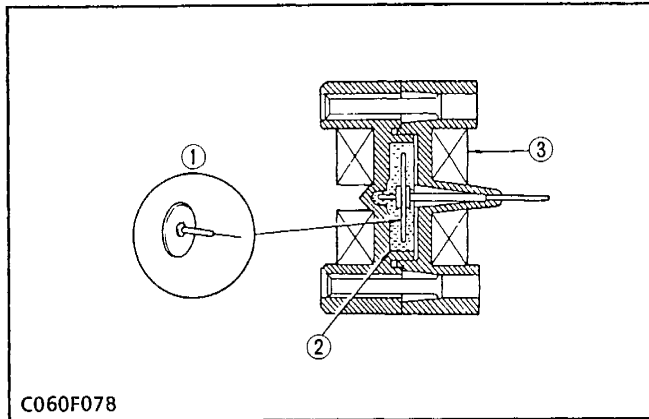

C060F078

- (1) Rotor (Magnet)
- (2) Silicone Oil
- (3) Coil

■ Coolant Temperature Gauge

The coolant temperature gauge is the same structure as the fuel gauge. But the rotor (1), which is disc type, is not symmetrical. Therefore, the pointer returns to the its original position when the main switch is turned off.

10 OTHERS

[1] TIRES

[1]-1 TYPES OF TIRE

The following tires can be mounted on Models B1550, B1750, B2150, B1550HST, B1750HST and B2150HST.

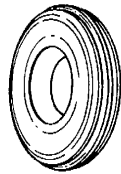
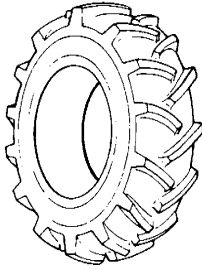
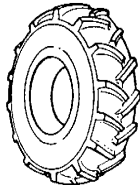
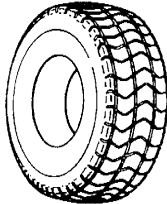
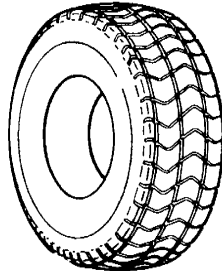
Type of Tire	Type of Tractor	Front Tire		Rear Tire	
Farm Tire	2 Wheel Drive	 C045F069	[B1550, B1550HST] 4.50-10-4PR 5.00-10-4PR [B1750, B1750HST] 5.00-10-4PR [B2150, B2150HST] 4.00-12-4PR 6.50-10-4PR	 C045F071	[B1550, B1550HST] 7-16-4PR 8-16-4PR [B1750, B1750HST] 8-16-4PR 9.5-16-4PR [B2150, B2150HST] 8.3-24-4PR 12.4-16-4PR
	4 Wheel Drive		 C045F070		[B1550, B1550HST] 6-12B-4PR [B1750, B1750HST] 6-12B-4PR 6-12-4PR [B2150, B2150HST] 6-12-4PR
Turf Tire	2 Wheel Drive	 0011F118	[B1550, B1550HST] 18 x 9.50-8-4PR [B1750, B1750HST] 18 x 9.50-8-4PR [B2150, B2150HST] 23 x 8.50-12-4PR	 C045F074	[B1550, B1550HST] 29 x 12.00-15-4PR 31 x 13.5-15-4PR [B1750, B1750HST] 29 x 12.00-15-4PR 31 x 13.5-15-4PR [B2150, B2150HST] 13.6-16-4PR
	4 Wheel Drive		[B1550, B1550HST] 20.5 x 8.00-10-4PR [B1750, B1750HST] 20.5 x 8.00-10-4PR [B2150, B2150HST] 24 x 8.5-12-4PR		[B1550, B1550HST] 29 x 12.00-15-4PR 31 x 13.5-15-4PR [B1750, B1750HST] 29 x 12.00-15-4PR 31 x 13.5-15-4PR [B2150, B2150HST] 13.6-16-4PR

[1]-2 TREAD ADJUSTMENT

(1) Front Wheel

The front tread can not be changed.

[2WD TYPE]

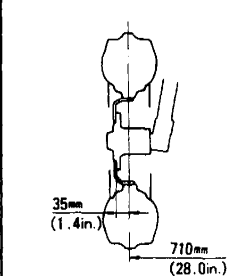
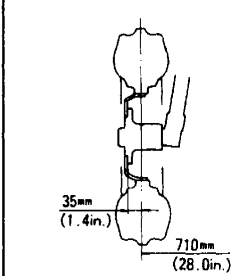
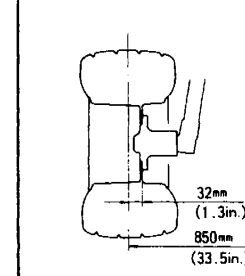
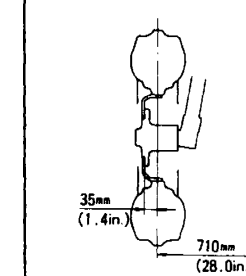
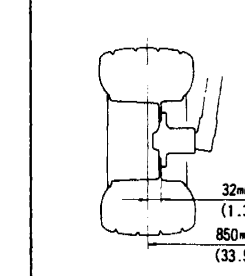
B1550, B1550HST			B1750, B1750HST	
4.50-10-4PR	5.00-10-4PR	18 x 9.50-8-4PR	5.00-10-4PR	18 x 9.50-8-4PR
				
0319F060	0319F060	0319F061	0319F060	0319F061

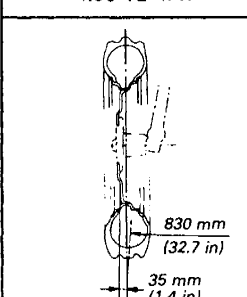
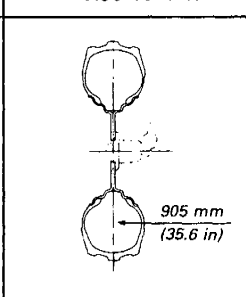
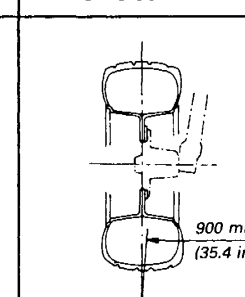
B2150, B2150HST		
4.00-12-4PR	6.50-10-4PR	23 x 8.50-12-4PR
		
0354F091	0354F092	0354F093

[4WD TYPE]

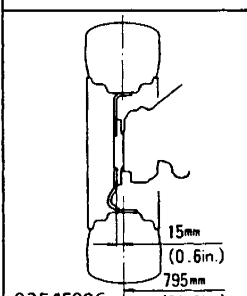
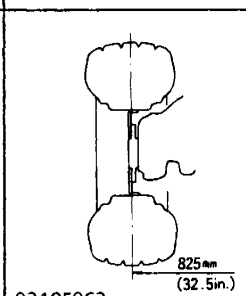
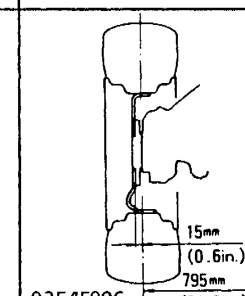
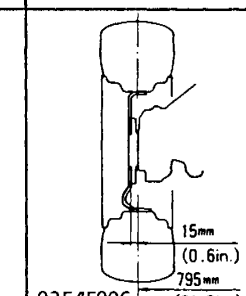
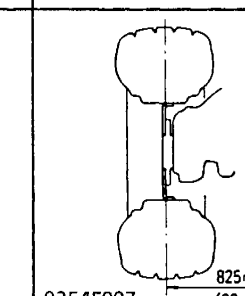
B1550, B1550HST		B1750, B1750HST		
6-12B-4PR	20.5 x 8.00-10-4PR	6-12B-4PR	6-12-4PR	20.5 x 8.00-10-4PR
				
0354F096	0319F063	0354F096	0354F096	0354F097

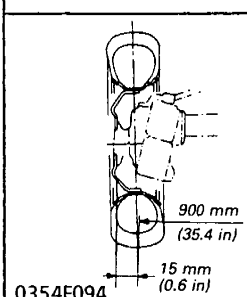
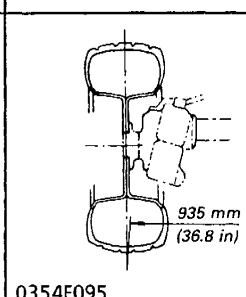
B2150, B2150HST	
6-12-4PR	24 x 8.5-12-4PR
	
0354F094	0354F095

(2) Rear Wheel

Rear tread can be adjusted in 3 or 4 steps depending on the tire size.

To change the tread

1. Lift the rear of the tractor with a jack.
2. Remount the rear wheel to the desired tread.
3. Check to see that the tire is turning in the proper direction as indicated by the arrow on the side of the tire.



CAUTION

- When working on slopes or when working with a trailer, set the wheel tread as wide as practical for the job for maximum stability.

■ IMPORTANT

- Always attach tire as shown in the figure.
- If not attached as the figure, transmission parts may be damaged.
- Do not use tires larger than specified.

[2WD-4WD TYPE]

B1550, B1550HST			
7-16-4PR	8-16-4PR	29 x 12.00-15-4PR	31 x 13.5-15-4PR
<p>0354F098</p>	<p>0354F099</p>	<p>0354F100</p>	<p>0354F101</p>
B1750, B1750HST			
8-16-4PR	9.50-16-4PR	29 x 12.00-15-4PR	31 x 13.5-15-4PR
<p>0354F102</p>	<p>0354F103</p>	<p>0354F104</p>	<p>0354F105</p>
B2150, B2150HST			
8.3-24-4PR	8.3-24 with spacer (OPT)	12.4-16-4PR	13.6-16-4PR
<p>0354F106</p>	<p>0354F107</p>	<p>0354F108</p>	<p>0354F109</p>

[1]-3 WHEEL HUB

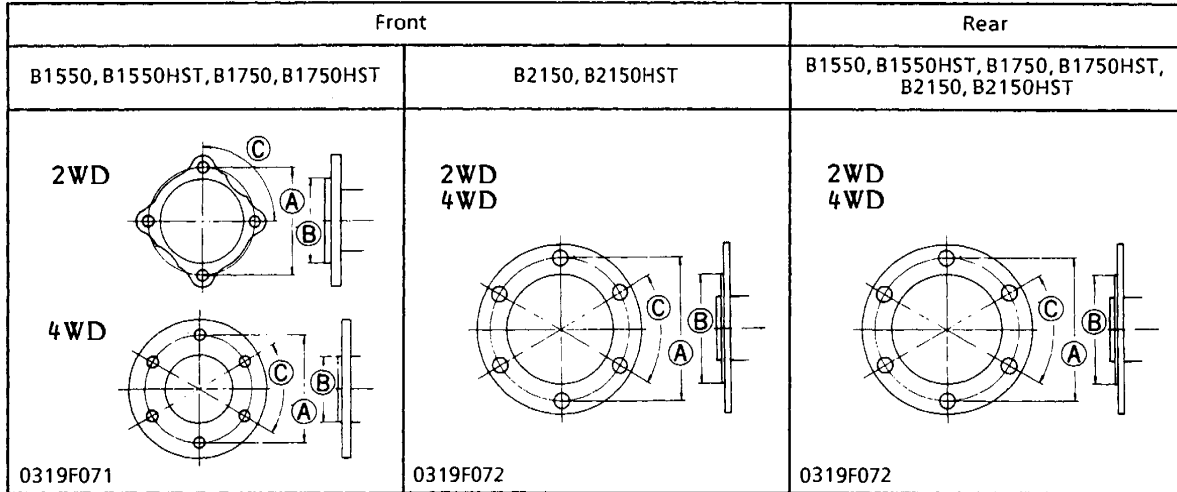

Model	Front Wheel Hub			Rear Wheel Hub	
	2WD	4WD	2WD/4WD	2WD/4WD	2WD/4WD
B1550, B1750 B1550HST, B1750HST					
Screw circle diameter (A)	115 mm (4.53 in.)	115 mm (4.53 in.)	115 mm (4.53 in.)	152 mm (6.0 in.)	150 mm (5.91 in.)
Number of screws	4	6	6	6	6
Screw specifications (mm)	M12 x Pitch 1.25	M12 x Pitch 1.25	M12 x Pitch 1.25	M14 x Pitch 1.5	M16 x Pitch 1.5
Pilot bore diameter (B)	90 mm (3.54 in.)	69.5 mm (2.74 in.)	69.5 mm (2.74 in.)	114 mm (4.49 in.)	110 mm (4.33 in.)
Hole spacing (C)	Equal 1.58 rad (90 deg.)	Equal 1.05 rad (60 deg.)	Equal 1.05 rad (60 deg.)	Equal 1.05 rad (60 deg.)	Equal 1.05 rad (60 deg.)

[1]-4 TIRE PRESSURE

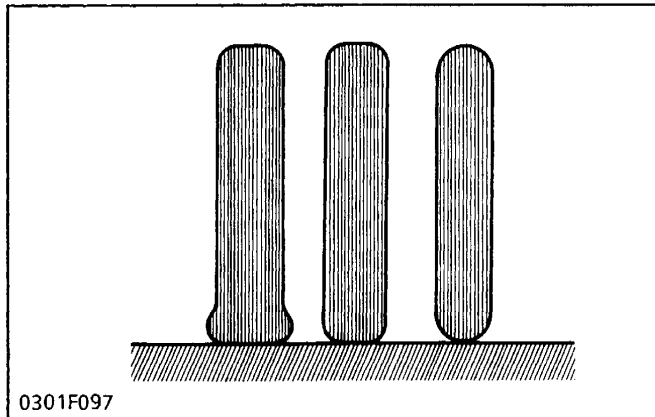

Although the tire pressure is factory-set to the prescribed level, it naturally drops slowly in the course of time. Thus, check it everyday and inflate as necessary. To inflate the wheel tires, use an air compressor or hand pump.

- Recommended inflation pressure:
Maintain the pressure as shown in the table below.

Front Tires	4.50-10-4PR	140 kPa (1.4 kgf/cm ² , 20 psi)
	5.00-10-4PR	270 - (2.8 - ,40 -)
	4.00-12-4PR	310 " (3.2 - ,46 -)
	6.50-10-4PR	200 - (2.0 - ,28 -)
	6-12-4PR	200 kPa (2.0 - ,28 -)
	18 x 9.50-8-4PR	140 - (1.4 - ,20 -)
	20.5 x 8.00-10-4PR	160 - (1.6 - ,23 -)
	23 x 8.50-12-4PR	160 - (1.6 - ,23 -)
	24 x 8.50-12-4PR	160 - (1.6 - ,23 -)
	Rear Tires	7-16-4PR
8-16-4PR		160 - (1.6 - ,23 -)
9.5-16-4PR		140 - (1.4 - ,20 -)
8.3-24-4PR		160 - (1.6 - ,23 -)
12.4-16-4PR		120 - (1.2 - ,17 -)
29 x 12.00-15-4PR		140 - (1.4 - ,20 -)
31 x 13.5-15-R		140 - (1.4 - ,20 -)
13.6-16-4PR		100 - (1.0 - ,14 -)

⚠ CAUTION

- Do not attempt to mount a tire. This should be done by a qualified person with proper equipment. Qualified persons with the proper tire mounting equipment should recognize the following warning.

⚠ WARNING

- Refer to the following page.

WARNING

- Never exceed the pressure shown in right (maximum limit) when attempting to seat a bead. If beads have not been seated by the time the pressure reaches maximum limit, deflate the assembly, reposition the tire on the rim, relubricate and reinflate. After seating the bead, adjust inflation pressure as recommended in the inflation pressure chart.

Maximum Limit of Inflation Pressure (In seating a bead)

Farm Tire	4.50-10-4PR 5.00-10-4PR 6-12-4PR 7-16-4PR 8-16-4PR 9.5-16-4PR 8.3-24-4PR 12.4-16-4PR 4.00-12-4PR 6.50-10-4PR	345kPa (3.5 kgf/cm ² , 50 psi)
Turf Tire	18 x 9.50-8-4PR 20.5 x 8.00-10-4PR 29 x 12.00-15-4PR 31 x 13.5-15-4PR 13.6-16-4PR 23 x 8.50-12-4PR 24 x 8.50-12-4PR	296kPa (3.0 kgf/cm ² , 43 psi)

[1]-5 TIRE LIQUID INJECTION

Auxiliary weights can be used to increase traction force for plowing in fields or clayey grounds. Another way is to inject water or another liquid, such as a calcium chloride solution, in the tires. Water must not be used in winter since it freezes at 0°C (32°F).

The calcium chloride solution will not freeze and moreover, affords higher effect than water since its specific gravity is higher than that of water by about 20%.

Preparation of Calcium Chloride Solution

CAUTION

- When making a calcium chloride solution, do not pour water over calcium chloride since this results in chemical reaction which will cause high temperature. Instead add a small amount of calcium chloride to the water at a time until the desired solution is achieved.

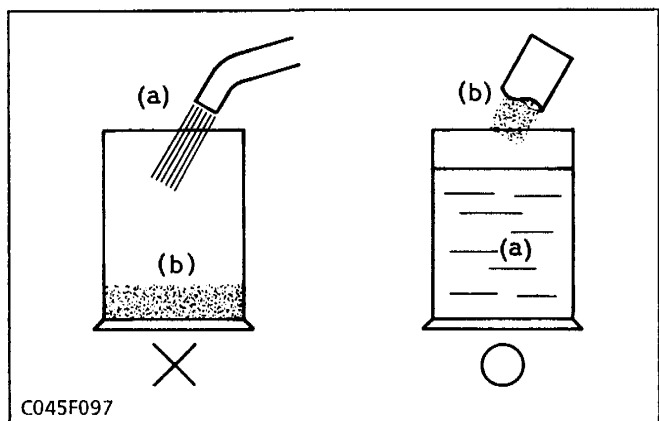

(a) Water

(b) CaCl₂

IMPORTANT

- Do not fill the following tires with water or calcium chloride solution.

- | | |
|-----------------|--------------------|
| 4.50-10-4PR | 20.5 x 8.00-10-4PR |
| 5.00-10-4PR | 29 x 12.00-15-4PR |
| 6-12-4PR | 31 x 13.5-15-4PR |
| 4.00-12-4PR | 23 x 8.50-12-4PR |
| 6.50-10-4PR | 24 x 8.50-12-4PR |
| 18 x 9.50-8-4PR | |

Freezing temp.	Weight of CaCl ₂ to be dissolved in 100 ℓ (26.5 U.S.gals., 22.0 Imp. gals.) of water
-5°C (23°F)	12 kg (26.4 lbs)
-10°C (14°F)	21 kg (46.3 lbs)
-15°C (5°F)	28 kg (61.7 lbs)
-20°C (-4°F)	34 kg (75.0 lbs)
-25°C (-13°F)	40 kg (88.2 lbs)
-30°C (-22°F)	44 kg (97.0 lbs)
-35°C (-31°F)	49 kg (108.0 lbs)
-40°C (-40°F)	52 kg (114.6 lbs)
-45°C (-49°F)	56 kg (123.5 lbs)
-50°C (-58°F)	61 kg (134.5 lbs)

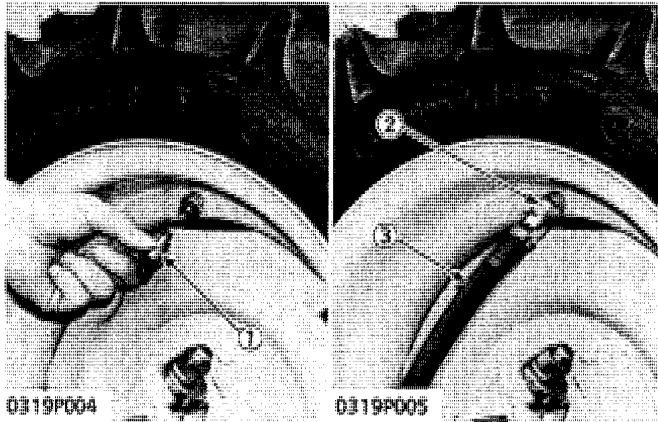

(1) Air Valve
(2) Injector

(3) Hose

Attaching Injector

1. Lift the rear tires off the ground.
2. Turn the tire so that the air valve is at the top.
3. Remove the air valve (1), and attach the injector (2) (Code No: 07916-52511).

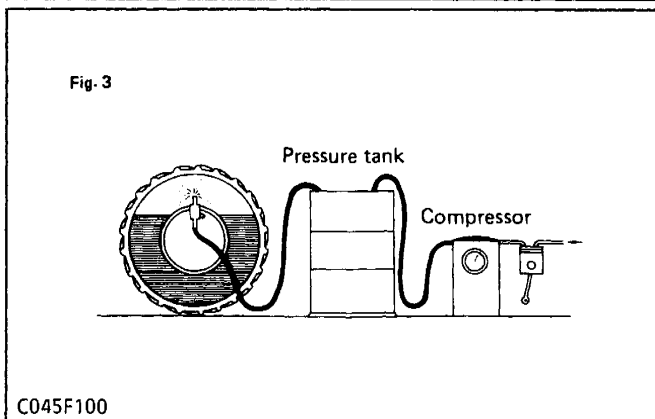
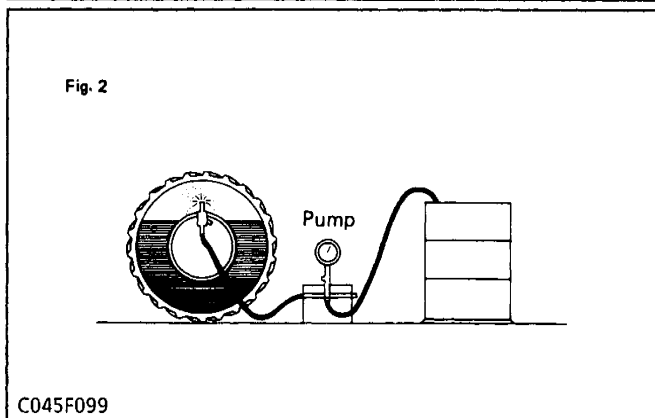
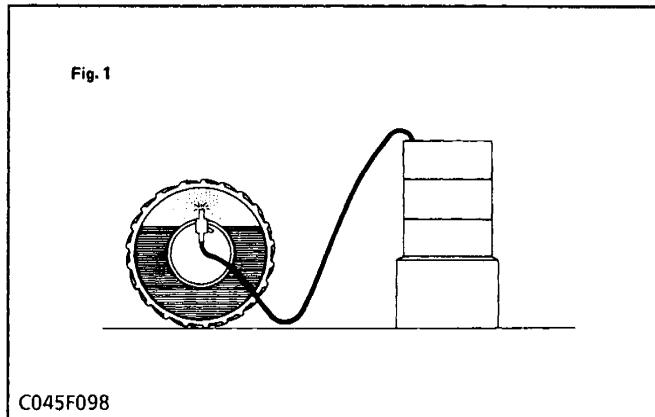

Injection

⚠ CAUTION

- When a calcium chloride solution is used, cool it before pouring it into the tire.

The following four ways can be used to inject water or calcium chloride solution into tires.

1. Gravity injection (Fig.1)
2. Pump injection (Fig.2)
3. Pressure tank injection (Fig.3)
4. Injection directly from tap (only when water is being used)

■ NOTE

- Once injection is completed, reset the air valve, and pump air into the tire to the specified pressure.

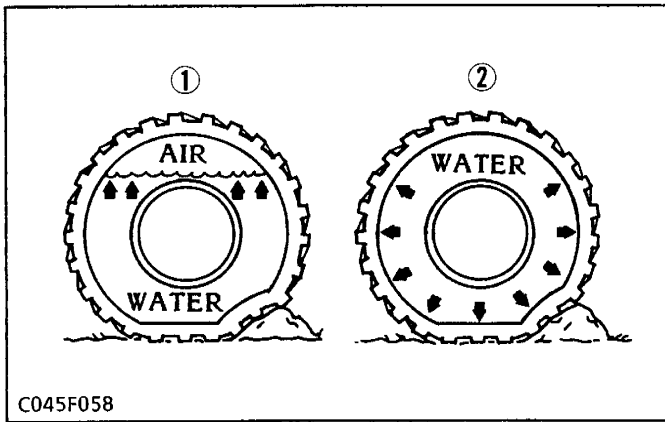

CAUTION

- Do not fill tires with water or solution more than 75% of full capacity (to the valve stem level).

- (1) Correct-75% (Air compresses like a cushion)
- (2) Incorrect-100% (Water can not be compressed)

C045F058

Weight of calcium chloride solution filling 75% of full capacity of a tire

Tire sizes	7-16-4PR	8-16-4PR	9.5-16-4PR	8.3-24-4PR	12.4-16-4PR
Slush free at -10°C(13°F) Solid at -30°C(-23°F) [Approx. 1 kg (2 lbs) CaCl ₂ per 4 l (1 gal) of water]	26 kg (58 lbs)	35 kg (78 lbs)	54 kg (119 lbs)	56 kg (123 lbs)	85 kg (187 lbs)
Slush free at -24°C(-12°F) Solid at -47°C(-52°F) [Approx. 1.5 kg (3.5 lbs) CaCl ₂ per 4 l (1 gal) of water]	28 kg (61 lbs)	37 kg (82 lbs)	57 kg (125 lbs)	60 kg (132 lbs)	89 kg (196 lbs)
Slush free at -47°C(-52°F) Solid at -52°C(-62°F) [Approx. 2.25 kg (5 lbs) CaCl ₂ per 4 l (1 gal) of water]	29 kg (64 lbs)	39 kg (86 lbs)	60 kg (132 lbs)	63 kg (139 lbs)	94 kg (207 lbs)

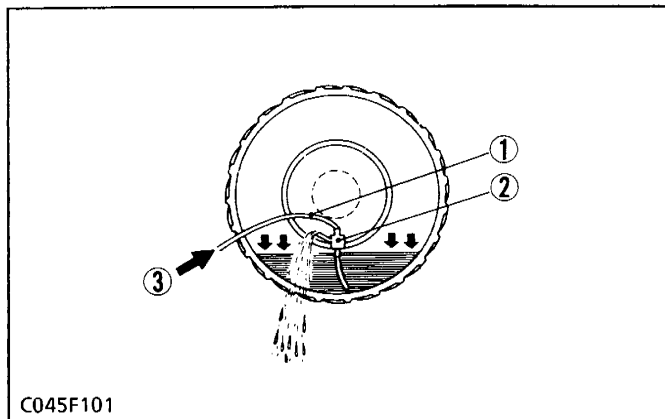

Draining Water or Solution

- Lift the rear tires off the ground.
- Turn the tire so that the air valve is at the bottom.
- Remove the air valve, and drain liquid (liquid can only be drained to the level of the valve and liquid under that level remains inside).
- To drain liquid completely, use the injector, and direct compressed air into the tire to force out the liquid through the injector's vent.

C045F101

- (1) Hose
- (2) Injector
- (3) Compressed Air

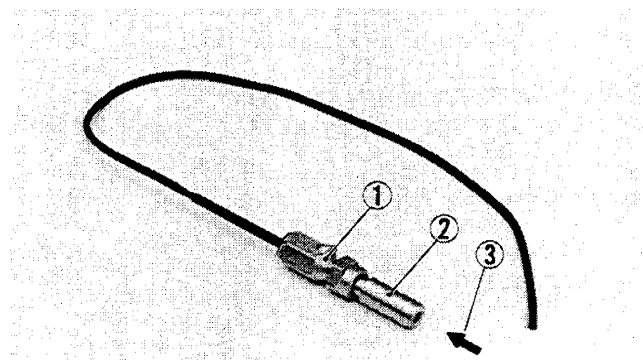

C045P001

- (1) Vent
- (2) Injector
- (3) Compressed Air

[2] SPECIFICATIONS OF IMPLEMENT LIMITATIONS

The Kubota tractor has been thoroughly tested for proper performance with implements sold or approved by Kubota. Use with implements which exceed the maximum specifications listed below, or which are otherwise unfit for use with the Kubota tractor may result in malfunctions or failures of the

tractor, damage to other property and injury to the operator or others.

(Any malfunctions or failure of the tractor resulting from use with improper implements are not covered by the warranty.)

Model		B1550-B1550HST	B1750-B1750HST	B2150-B2150HST
Operating condition		General control operation (Flat ground and slope condition)		
Lower link end max. loading weight W0		Below 180 kg (400 lbs)		Below 360 kg (800 lbs)
Actual figures	Implement weight W1	As in the following list		
	Trailer loading weight W2	Below 500kg (1100 lbs) (without brake) Below 1000kg (2200 lbs) (with brake)		Below 1500 kg (3300 lbs)

Lower link end max. loading weight	The max. allowable load which can be put the lowest link end : W0
Implement weight	The implement's weight which can be put on the lower link : W1
Trailer loading weight	The max. loading weight for trailer (without trailer's weight) : W2

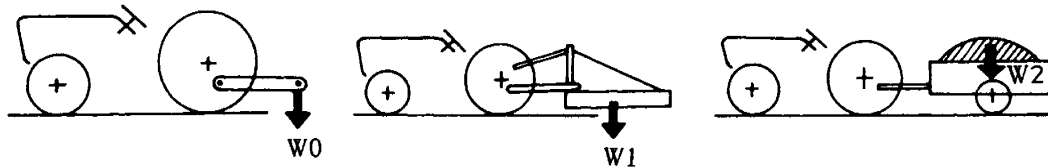

0319F073

Implement		Remarks	B1550,B1550HST	B1750,B1750HST	B2150-2WD B2150HST-2WD	B2150-4WD B2150HST-4WD
Rotary mower	Rear (1 Blade)	Max. cutting width Max. weight	107 cm (42 in.) 140 kg (300 lbs.)	107 cm (42 in.) 140 kg (300 lbs.)	122 cm (48 in.) 227 kg (500 lbs.)	122 cm (48 in.) 227 kg (500 lbs.)
	Mid or rear (2 to 3 Blade)	Max. cutting width Max. weight	152 cm (60 in.) 140 kg (300 lbs.)	152 cm (60 in.) 140 kg (300 lbs.)	183 cm (72 in.) 227 kg (500 lbs.)	183 cm (72 in.) 227 kg (500 lbs.)
	Sickle bar	Max. cutting width	122 cm (48 in.)	122 cm (48 in.)	152 cm (60 in.)	152 cm (60 in.)
Rotary tiller		Max. tilling width Max. weight	107 cm (42 in.) 170 kg (380 lbs.)	107 cm (42 in.) 180 kg (400 lbs.)	127 cm (50 in.) 250 kg (550 lbs.)	127 cm (50 in.) 250 kg (550 lbs.)
Bottom plow		Max. size	30 cm (12 in.) X 1	36 cm (14 in.) X 1	36 cm (14 in.) X 1	30 cm (12 in.) X 2
Disc plow		Max. size	56 cm (22 in.) X 1	56 cm (22 in.) X 1	56 cm (22 in.) X 2	56 cm (22 in.) X 2
Cultivator		Max. size	122 cm (48 in.) 1 Row	122 cm (48 in.) 1 Row	137 cm (54 in.) 1 Row	152 cm (60 in.) 1 Row
Disc harrow		Max. harrowing width Max. weight	122 cm (48 in.) 90 kg (200 lbs.)	137 cm (54 in.) 140 kg (300 lbs.)	168 cm (66 in.) 250 kg (550 lbs.)	168 cm (66 in.) 250 kg (550 lbs.)
Sprayer		Max. tank capacity	110 ℓ (30 gals.)	110 ℓ (30 gals.)	246 ℓ (65 gals.)	246 ℓ (65 gals.)
Front blade		Max. cutting width Sub frame Oil pressure relief valve	122 cm (48 in.) Necessary 11.4 MPa (116 kgf/cm ² , 1650 psi)	122 cm (48 in.) Necessary 11.4 MPa (116 kgf/cm ² , 1650 psi)	168 cm (66 in.) Necessary Max.Weight 250 kg (550 lbs.)	168 cm (66 in.) Necessary Max.Weight 250 kg (550 lbs.)
Rear blade		Max. cutting width Max. weight	152 cm (60 in.) 140 kg (360 lbs.)	152 cm (60 in.) 160 kg (350 lbs.)	168 cm (66 in.) 250 kg (550 lbs.)	168 cm (66 in.) 250 kg (550 lbs.)
Front-end loader		Max. lifting capacity Max. width Oil pressure, relief valve Sub frame necessary	270 kg (600 lbs.) 107 cm (42 in.) 11.27 MPa (115 kgf/cm ² , 1636 psi) Necessary	270 kg (600 lbs.) 107 cm (42 in.) 11.27 MPa (115 kgf/cm ² , 1636 psi) Necessary	380 kg (838 lbs.) 127 cm (50 in.) 11.27 MPa (115 kgf/cm ² , 1636 psi) Necessary	380 kg (838 lbs.) 127 cm (50 in.) 11.27 MPa (115 kgf/cm ² , 1636 psi) Necessary
Box blade		Max. cutting width Max. weight	107 cm (42 in.) 170 kg (380 lbs.)	107 cm (42 in.) 170 kg (380 lbs.)	132 cm (52 in.) 227 kg (500 lbs.)	132 cm (52 in.) 227 kg (500 lbs.)
Back hoe (Use maximum rear wheel tread width)		Max. digging depth Max. weight Sub frame	183 cm (72 in.) 270 kg (600 lbs.) Necessary	183 cm (72 in.) 270 kg (600 lbs.) Necessary	183 cm (72 in.) 363 kg (800 lbs.) Necessary	183 cm (72 in.) 363 kg (800 lbs.) Necessary
Snow blower		Max. working width Max. weight Sub frame	107 cm (42 in.) 160 kg (350 lbs.) Necessary	122 cm (48 in.) 160 kg (350 lbs.) Necessary	152 cm (60 in.) 227 kg (500 lbs.) Necessary	152 cm (60 in.) 227 kg (500 lbs.) Necessary
Trailer		Max. load capacity	500 kg (1100 lbs.)	500 kg (1100 lbs.)	1500 kg (3300 lbs.)	1500 kg (3300 lbs.)
Three point lift		Max. load capacity	180 kg (400 lbs.)	180 kg (400 lbs.)	360 kg (800 lbs.)	360 kg (800 lbs.)

B&W 11x17

INSERT

M.10-10

[4] CHARGING SYSTEM (Alternator type for Canada)

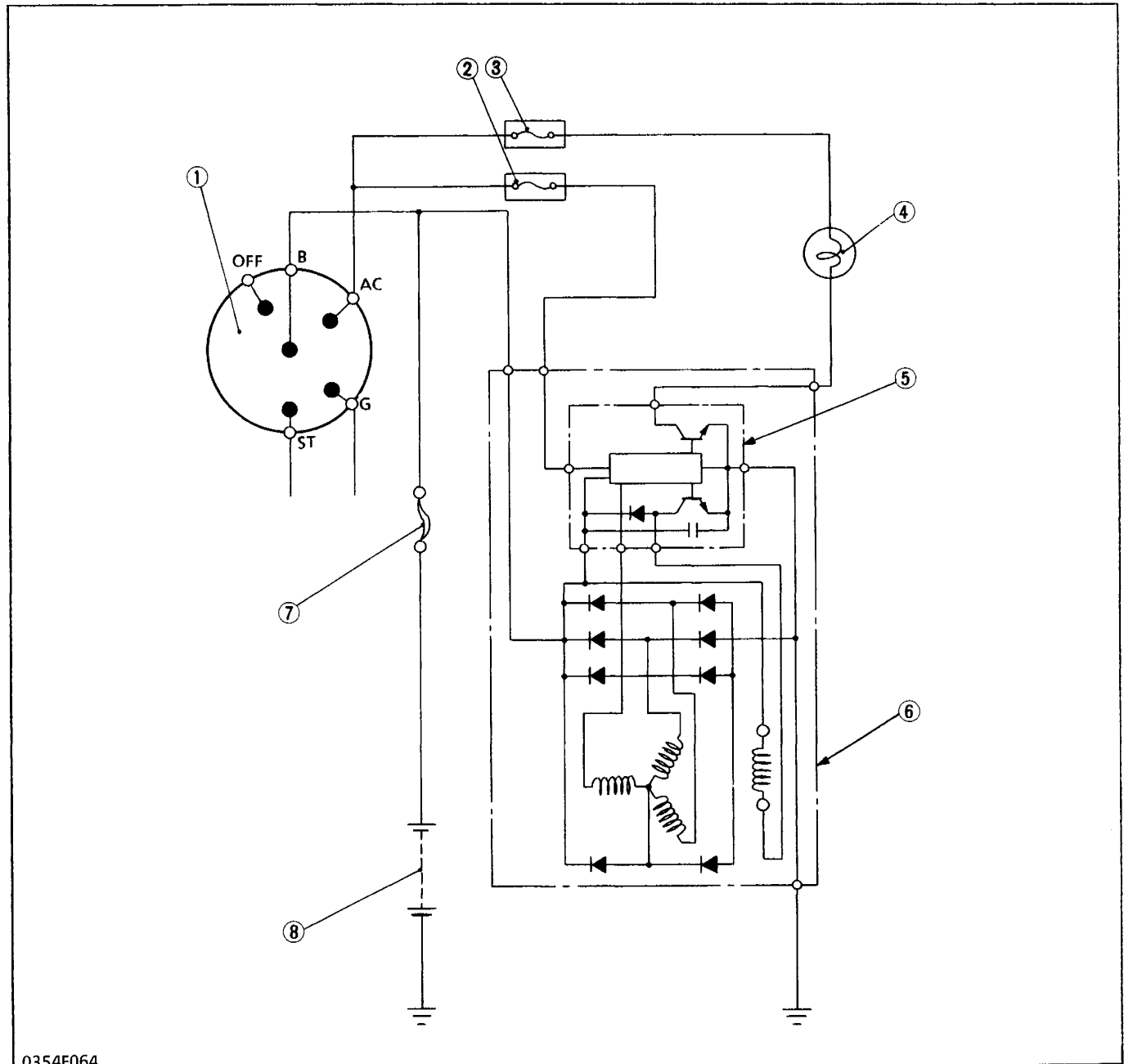

0354F064

- | | | | |
|-----------------|-----------------|------------------|------------------|
| (1) Main Switch | (3) Fuse | (5) IC Regulator | (7) Fusible Link |
| (2) Fuse | (4) Charge Lamp | (6) Alternator | (8) Battery |

The charging system supplies electric power for various electrical devices and also charges the battery while the engine runs.
This alternator has an IC regulator.

NOTE
 • As for the other items, refer to "ELECTRICAL SYSTEM" on page M.9-1 to M.9-27.

(1) Alternator

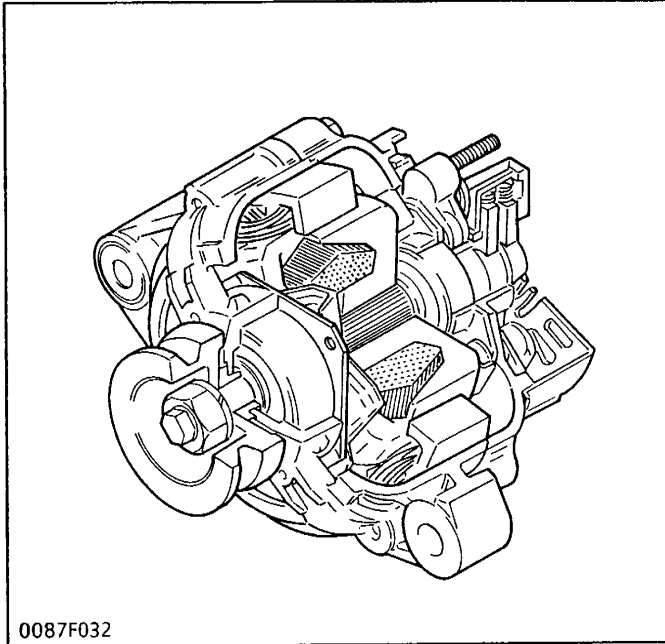

A compact alternator with an IC regulator is used, having the following characteristics:

- Approximately 26% lighter and 17% smaller than a standard alternator
- A cooling performance and safety have been improved by combining the cooling fan with the rotor and incorporating the fan/rotor unit inside the alternator.
- The IC regulator is fitted inside the alternator
- The rectifier, IC regulator and similar components are easy to remove, making it easier to service the alternator.

(2) IC Regulator

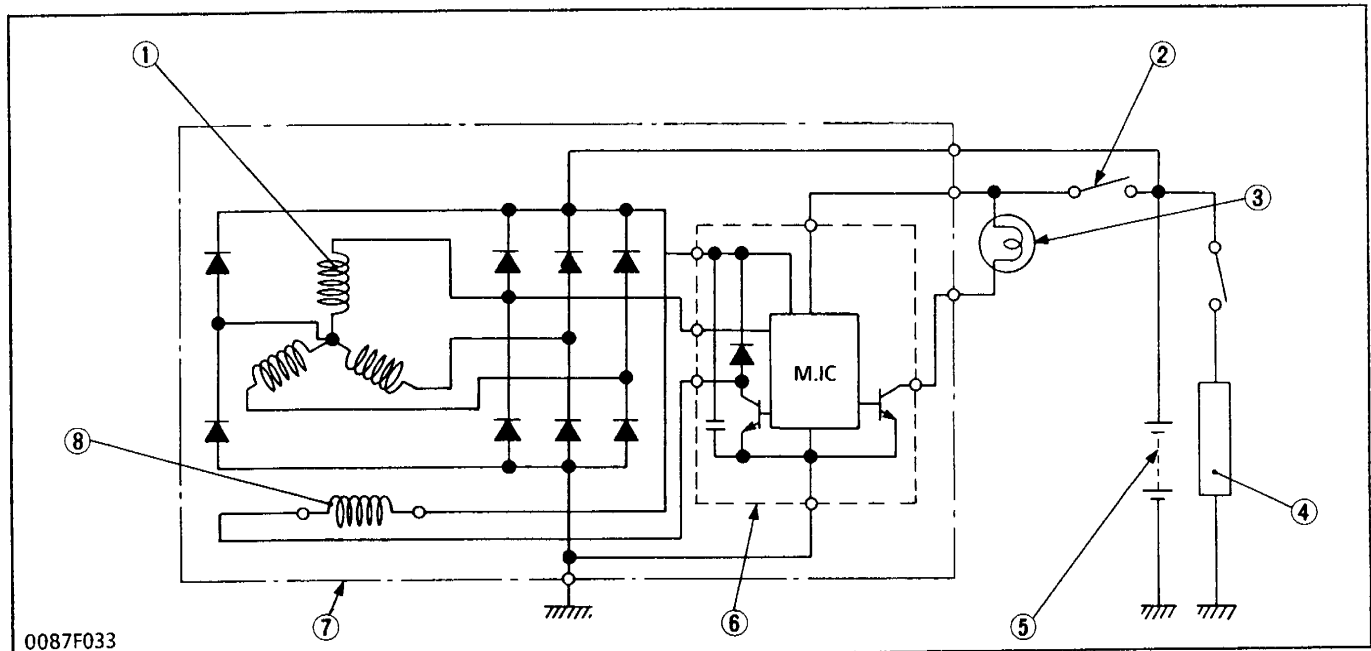

- | | | | |
|-----------------|-----------------|------------------|----------------|
| (1) Stator Coil | (3) Charge Lamp | (5) Battery | (7) Alternator |
| (2) Main Switch | (4) Load | (6) IC Regulator | (8) Rotor Coil |

An IC regulator uses solid state transistors, chips or other semiconductor elements instead of the relays in a conventional regulator. Stable characteristics are achieved by cutting off the field current.

IC regulators have the following characteristics:

- The control voltage does not change over time, so the need for readjustment is eliminated. Since there are no moving parts, IC regulators are extremely durable and resistant to vibration.
- The overheat compensation characteristics ensure that the control voltage is reduced as the temperature rises, so the battery is charged at just the right level.

The internal circuitry of the IC regulator is shown in the diagram. It consists of a hybrid IC incorporating a monolithic IC. (The internal circuitry of the monolithic IC is extremely complex, so it is shown as simply "M.IC circuit".

Tr1 acts as the contacts controlling the field current, and Tr2 acts as the charge lamp relay controlling the flashing of the charge lamp.

The M.IC circuit controls Tr1 and Tr2, and monitors the alternator output voltage, and detects any drop in L terminal voltage or breaks in the rotor coil

(3) Operation of Charging System

(3)-1 When Main Switch Is Turned To "ON" Position

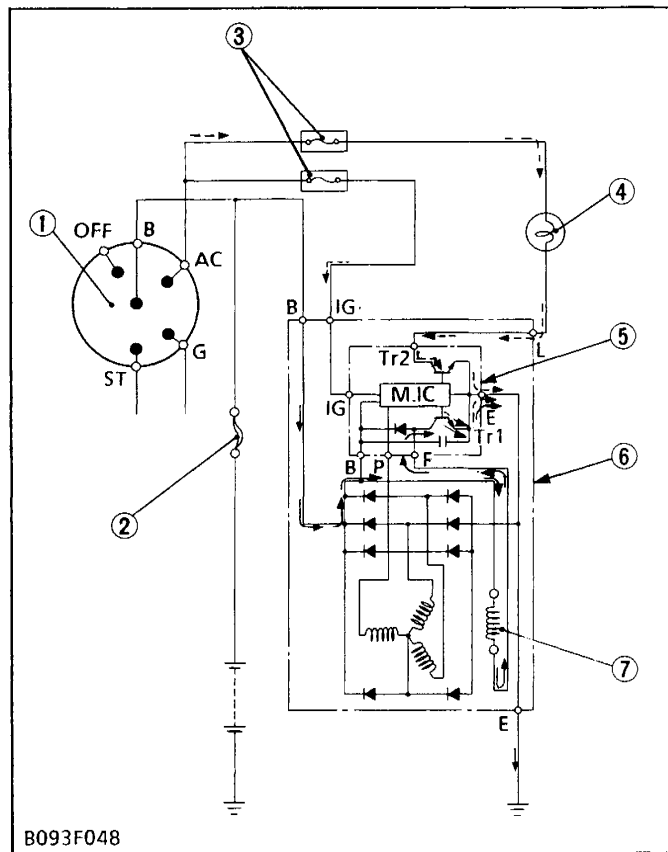

B093F048

As the battery voltage is added to the terminal IG, M.I.C circuit detect it and makes current pour to the Tr1. It results to pour the initial exciting current to the rotor coil. (In this case, M.I.C circuit makes current pour on and off the Tr1 in pulse and limits the battery discharging current to small value (Approx. 0.17 A) when the main switch is turned on.)

As the alternator is not rotated, it doesn't generate. Therefore the voltage of terminal P is zero volt. M.I.C circuit detects it and makes current pour to the Tr2. It results light on the charge lamp.

- | | |
|------------------|-----------------------|
| (1) Main Switch | (6) Alternator |
| (2) Fusible Link | (7) Rotor Coil |
| (3) Fuses | M.I.C : Monolithic IC |
| (4) Charge Lamp | Tr1 : Transistor |
| (5) IC Regulator | Tr2 : Transistor |

(3)-2 When Engine Starts

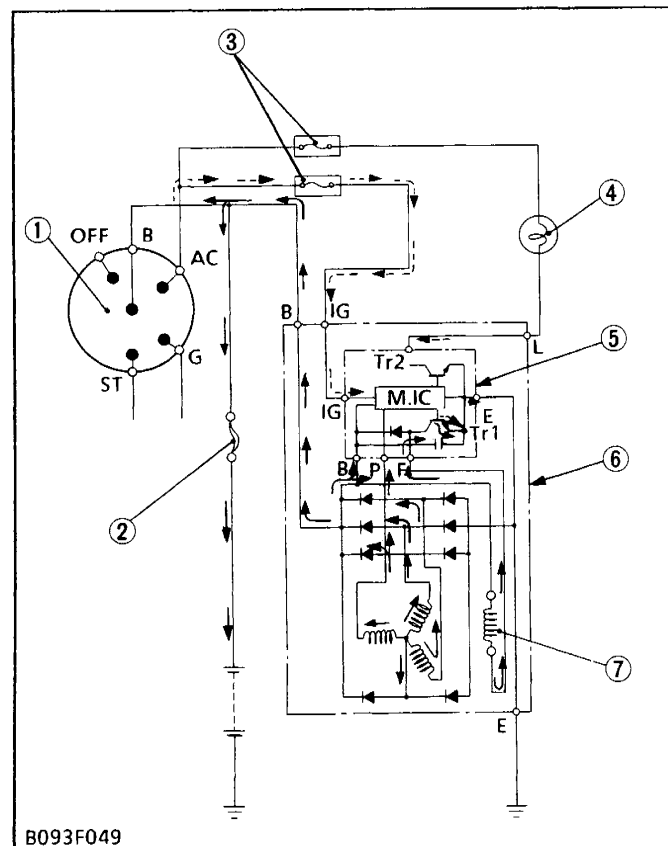

B093F049

When the engine starts and the alternator rotates, M.I.C circuit makes current pour continuously to the Tr1 instead of the uncontinuous (in pulse) current. Therefore a sufficient exciting current flows and a generated voltage rises rapidly. As a result, the current to the Tr2 is shut and lights off the charge lamp.

When terminal B voltage rises over the battery voltage, a charged current flows to the battery.

- | | |
|------------------|-----------------------|
| (1) Main Switch | (6) Alternator |
| (2) Fusible Link | (7) Rotor Coil |
| (3) Fuses | M.I.C : Monolithic IC |
| (4) Charge Lamp | Tr1 : Transistor |
| (5) IC Regulator | Tr2 : Transistor |

CONTENTS

[1] TRACTOR IDENTIFICATION	S.G-1
[2] GENERAL PRECAUTIONS	S.G-1
[3] FILTER CODE NO.	S.G-2
[4] LUBRICANTS AND FLUID	S.G-3
[5] TIGHTENING TORQUES (GENERAL USE SCREWS, BOLTS AND NUTS)	S.G-4
[6] MAINTENANCE CHECK LIST	S.G-5
[7] CHECK AND MAINTENANCE	
(1) Check Point of Initial 50 Hours	S.G-6
(2) Check Point of Initial 100 Hours	S.G-8
(3) Check Point of Every 100 Hours	S.G-9
(4) Check Point of Every 200 Hours	S.G-14
(5) Check Point of Every 300 Hours	S.G-15
(6) Check Point of Every 400 Hours	S.G-16
(7) Check Point of Every 600 Hours, Every Year or Every 6 Times of Cleaning	S.G-16
(8) Check Point of Every 1 or 2 Months	S.G-17
(9) Check Point of Every Year	S.G-17
(10) Check Point of Every 2 Years	S.G-18
(11) Check Point of Every 800 Hours	S.G-19
(12) Check Point of Daily	S.G-19
(13) Fuel	S.G-20
(14) Original Charge of Dry Type Battery	S.G-21
[8] SPECIAL TOOLS	
(1) Special Tools for Engine	S.G-22
(2) Special Tools for Tractor	S.G-28

[1] TRACTOR IDENTIFICATION

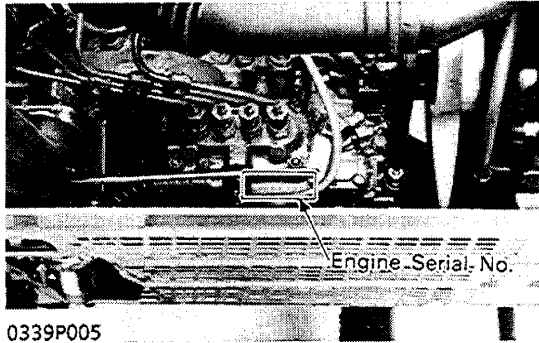
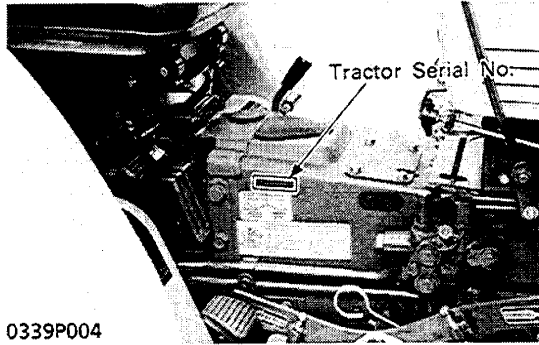

When contacting your local KUBOTA distributor, always specify engine serial number, tractor serial number and hour meter reading.

[2] GENERAL PRECAUTION



- Be sure to check and service the tractor on a flat place with engine shut off and the parking brake on.

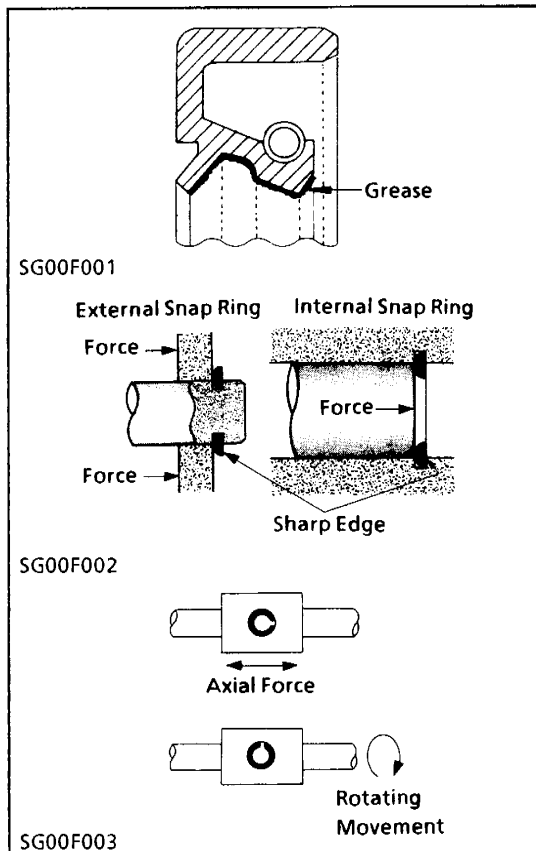

- During disassembly, carefully arrange removed parts in a clean area to prevent confusion later. Screws and nuts should be installed in their original position to prevent reassembly errors.
- When special tools are required, use KUBOTA genuine special tools. Special tools which are not frequently used should be made according to the drawings provided.
- Before disassembling or servicing electrical wires, always disconnect the ground cable from the battery first.
- Remove oil and dirt from parts before measuring.
- Use only KUBOTA genuine parts for parts replacement to maintain tractor performance and to assure safety.
- Gaskets and O-rings must be replaced during reassembly. Apply grease to new O-rings or oil seals before assembling. See the left figure.
- When reassembling external snap rings or internal snap rings, they must be positioned so that sharp edge faces against the direction from which a force is applied. See the left figure.
- When inserting spring pins, their splits must face the direction from which a force is applied. See the figure below.
- To prevent damage to the hydraulic system, use only specified fluid or equivalent.

[3] FILTER CODE NO.

Replacing the filters with new, refer to each code No. in the following table.

■ IMPORTANT

- To avoid serious damage to the engine and tractor, replacement element must be of high quality. Use only a genuine Kubota filter.

Filter	Model	B1550-B1750	B1550HST-B1750HST	B2150	B2150HST
Engine oil filter (Cartridge type)		Code No. 15241-32092 ① 810 cm ² ③ — ⑤ M20xPitch 1.5 mm ② 16 ℓ/min ④ 12 kg/cm ² ⑥ Less than 0.4 kg/cm ² (Under the max. oil flow) ⑦ More than 7 kg/cm ²			
Fuel filter (Cartridge type)		Code No. 15231-43563 ① More than 250 cm ² ③ 10 μ ⑤ — ② — ④ — ⑥ Less than 800mmAq (Under the fuel flow 2 ℓ/min)			
Hydraulic oil filter (Cartridge type)		—	Code No. 66021-36061 Spec. ① 1520 cm ² ② 30 ℓ/min ③ 10 μ ④ 15 kgf/cm ² ⑤ 3/4" -16 UNF-2B	Code No. 38430-37714 Spec. ① 400 cm ² ② 23 ℓ/min ③ 150 mesh ④ 16 kgf/cm ² ⑤ M20 Pitch 1.5 mm	Code No. 66361-37951 Spec. ① 1850 cm ² ② 27.5 ℓ/min ③ 10 μm ④ 17 kgf/cm ² ⑤ 16 UN-1-1/8-2B
Air cleaner (Element)		Code No. 15852-11221 ① 4800 cm ² ② 2.0 m ³ /min. ⑥ Less than 190 mmAq		Code No. 15741-11081 ① 8800 cm ² ② 2.7 m ³ /min. ⑥ Less than 280 mmAq	
Hydraulic oil strainer		Code No. 66611-36121		—	Code No. 67800-37121
		—	Code No. 66204-36211		

(1) Filtration Area
(2) Oil (Air) Flow

(3) Filtration Grain Size of Filter
(4) Resisting Pressure

(5) Setting Screw Size
(6) Pressure Drop



(7) Differential Pressure
Strength

[4] LUBRICANTS AND FLUID

Place	Capacity			Lubricants and Fluid																				
	B1550 B1550HST	B1750 B1750HST	B2150 B2150HST																					
Place	18 ℓ (4.8 US. gals) (15.8 Imp.qts)		28 ℓ (7.4 US. gals) (6.2 Imp.qts)	Diesel fuel No. 1-D (below - 10°C (15°F)) Diesel fuel No. 1-D (above - 10°C (15°F)) (ASTM D975)																				
Coolant	2.9 ℓ (3.1 US. qts) (2.6 Imp.qts)	3.5 ℓ (3.7 US. qts) (3.1 Imp.qts)	3.9 ℓ (4.1 US. qts) (3.4 Imp.qts)	Fresh clean water with anti-freeze																				
Engine Crankcase	3.1 ℓ (3.3 US. qts) (2.7 Imp.qts)		4.2 ℓ (4.4 US. qts) (3.7 Imp.qts)	<ul style="list-style-type: none"> MIL-L46152 or MIL-L-2104C API Service CC or CD <p>Below 0°C (32°F) SAE 10W or 10W - 30 0° to 25°C (32° to 77°F) SAE 20W or 10W - 30 Above 25°C (77°F) SAE 30W or 10W - 30</p>																				
Transmission Case	12 ℓ (12.7 US. qts) (10.6 Imp.qts)		18 ℓ (19 US. qts) (15.8 Imp.qts)	The oil used to lubricated the transmission is also used as hydraulic fluid. To insure proper operation of the hydraulic system and complete lubrication of the transmission, it is important that a multi-grade transmission fluid be used in this system. Kubota UDT oil and the following are recommended oils, by brand name, that may be used in the transmission hydraulic system. Multi-grade transmission fluid <table style="width:100%; border:none;"> <tr> <td style="text-align:center">Maker</td> <td style="text-align:center">Brand Name</td> </tr> <tr> <td>Atlantic Richfield (Arco)</td> <td>Arco Tractor Fluid</td> </tr> <tr> <td>Chevron</td> <td>Tractor Hydraulic Fluid</td> </tr> <tr> <td>Exxon</td> <td>Hydra-Trans and Wet Br.</td> </tr> <tr> <td>Phillips</td> <td>H.T.Fluid</td> </tr> <tr> <td>Shell</td> <td>Donax TD, TT, TM</td> </tr> <tr> <td>Texaco</td> <td>T.D.H Oil</td> </tr> <tr> <td>Union</td> <td>hydraulic / Tractor Fluid</td> </tr> <tr> <td>Gulf</td> <td>Universal Fluid 425, 350</td> </tr> <tr> <td>Mobil</td> <td>Mobil Fluid 423, 350</td> </tr> </table>	Maker	Brand Name	Atlantic Richfield (Arco)	Arco Tractor Fluid	Chevron	Tractor Hydraulic Fluid	Exxon	Hydra-Trans and Wet Br.	Phillips	H.T.Fluid	Shell	Donax TD, TT, TM	Texaco	T.D.H Oil	Union	hydraulic / Tractor Fluid	Gulf	Universal Fluid 425, 350	Mobil	Mobil Fluid 423, 350
Maker	Brand Name																							
Atlantic Richfield (Arco)	Arco Tractor Fluid																							
Chevron	Tractor Hydraulic Fluid																							
Exxon	Hydra-Trans and Wet Br.																							
Phillips	H.T.Fluid																							
Shell	Donax TD, TT, TM																							
Texaco	T.D.H Oil																							
Union	hydraulic / Tractor Fluid																							
Gulf	Universal Fluid 425, 350																							
Mobil	Mobil Fluid 423, 350																							
	for HST 13.5 ℓ (14.3 US. qts) (11.9 Imp.qts)		for HST 18 ℓ (19 US. qts) (15.8 Imp.qts)																					
Steering Gear Box	0.2 ℓ (0.2 US. qts)(0.2 Imp.qts)			Gear oil SAE 80 or SAE 90																				
Front axle differential case (4WD)	0.5 ℓ (0.5 US. qts) (0.4 Imp.qts)	1.5 ℓ (1.6 US. qts) (1.3 Imp.qts)		Gear oil SAE 80 or SAE 90																				
	Bi-speed turn 2.5 ℓ (2.6 US. qts) (2.2 Imp.qts)		Bi-speed turn —																					
Front axle gear case (Right or left) (4WD)	0.15 ℓ (0.16 US. qts) (0.13 Imp.qts)	0.5 ℓ (0.5 US. qts) (0.4 Imp.qts)		Gear oil SAE 80 or SAE 90																				
King pins (2WD), Center pin (2WD), Pedal shaft, Clutch release hub, Seat adjuster, Range selector lever, Speed control pedal shaft (HST)	Moderate amount			SAE multi-purpose type grease																				

[5] TIGHTENING TORQUES (GENERAL USE SCREWS, BOLTS AND NUTS)

Screws, bolts and nuts whose tightening torques are not specified in this Workshop Manual should be tightened according to the table below.

Grade Unit Nominal Dia.	* No-grade or 4T 			7T 			9T 		
	N·m	kgf·m	ft·lbs	N·m	kgf·m	ft·lbs	N·m	kgf·m	ft·lbs
M6 6 mm, 0.24 in.	7.85 to 9.30	0.80 to 0.95	5.79 to 6.87	9.80 to 11.2	1.00 to 1.15	7.24 to 8.32	12.3 to 14.2	1.25 to 1.45	9.1 to 10.5
M8 8 mm, 0.31 in.	17.7 to 20.5	1.8 to 2.1	13.0 to 15.2	23.6 to 27.4	2.4 to 2.8	17.4 to 20.2	29.4 to 34.3	3.0 to 3.5	21.7 to 25.3
M10 10 mm, 0.39 in.	39.2 to 45.0	4.0 to 4.6	29.0 to 33.2	48.1 to 55.8	4.9 to 5.7	35.5 to 41.2	60.8 to 70.5	6.2 to 7.2	44.9 to 52.1
M12 12 mm, 0.47 in.	62.8 to 72.5	6.4 to 7.4	46.3 to 53.5	77.5 to 90.1	7.9 to 9.2	57.2 to 66.5	103 to 117	10.5 to 12.0	76.0 to 86.8
M14 14 mm, 0.55 in.	108 to 125	11.0 to 12.8	79.6 to 92.5	124 to 147	12.6 to 15.0	91.2 to 108	167 to 196	17.0 to 20.0	123 to 144
M16 16 mm, 0.63 in.	167 to 191	17.0 to 19.5	123 to 141	196 to 225	20.0 to 23.0	145 to 166	260 to 303	26.5 to 31.0	192 to 224
M18 18 mm, 0.71 in.	245 to 284	25.0 to 29.0	181 to 210	275 to 318	28.0 to 32.5	203 to 235	343 to 401	35.0 to 41.0	254 to 297
M 20 20 mm, 0.79 in.	334 to 392	34.0 to 40.0	246 to 289	368 to 431	37.5 to 44.0	272 to 318	490 to 568	50.0 to 58.0	362 to 420

* The figures on the table above are indicated the top of screw or bolt.

[6] MAINTENANCE CHECK LIST

Frequency of Checks	Check Points	Reference Pages
Initial operation (initial 50 hours)	During this period, pay special attention to the following. (1) After the initial 50 hours of use, change engine oil and engine oil filter cartridge and check fan drive belt tension. Replace transmission oil filter cartridge for HST. (2) After the initial 100 hours of use, change transmission fluid and clean transmission strainer.	S.G-6, 7, 8 S.G-8
Every 100 hours	Change engine oil. Clean fuel filter. Clean air cleaner element. Lubricate the following points. King pins, pedal shaft, center pin, clutch release hub, speed control pedal shaft for HST Check clutch pedal play range. Check brake pedal play range. Check steering wheel play range. Check battery electrolyte level. Check fuel line.	S.G-6 S.G-9 S.G-9, 10 S.G-11 S.G-11 S.G-12 S.G-12 S.G-13 S.G-14
Every 200 hours	Replace engine oil filter cartridge. Check radiator hose and hose clamp. Check fan drive belt tension.	S.G-6 S.G-14 S.G-7, 15
Every 300 hours	Change transmission fluid. Replace transmission oil filter cartridge for HST Change front axle differential case oil. Change steering gear box oil. Change front axle gear case (right and left) oil. Clean transmission strainer.	S.G-8, 15 S.G-7, 15 S.G-15 S.G-15 S.G-16 S.G-8, 16
Every 400 hours	Replace fuel filter.	S.G-9, 16
Every 600 hours every year or every 6 times of cleaning	Replace air cleaner element.	S.G-9, 10, 16
Every one to two months	Recharge battery if necessary.	S.G-17
Every year	Change anti-freeze and coolant Clean radiator.	S.G-17 S.G-18
Every 2 years	Replace battery, if necessary. Replace radiator hose, if necessary. Replace fuel line, if necessary. Replace hydraulic hose, if necessary	S.G-13, 18 S.G-14, 18 S.G-14, 18 S.G-19
Every 800 hours	Check valve clearance.	S.G-19
Daily	Check radiator screen. Check oil cooler exterior. (Only for B1550HST, B1750HST, B2150HST) Check coolant level. Check oil and fuel level. Check tire pressure.	S.G-18, 19 S.G-19 S.G-19 S.G-19 S.G-19

[7] CHECK AND MAINTENANCE

(1) Check Points of Initial 50 Hours

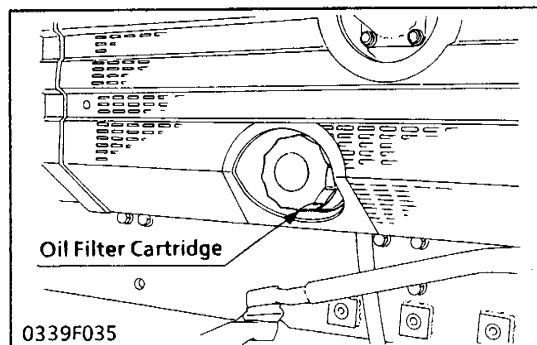
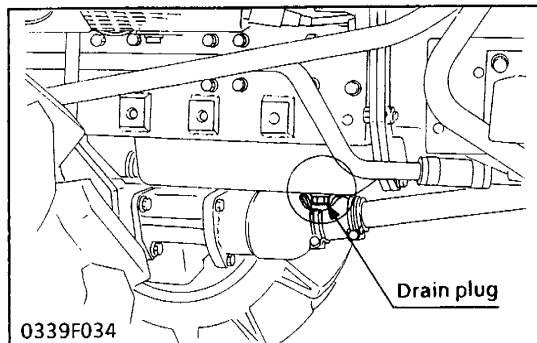
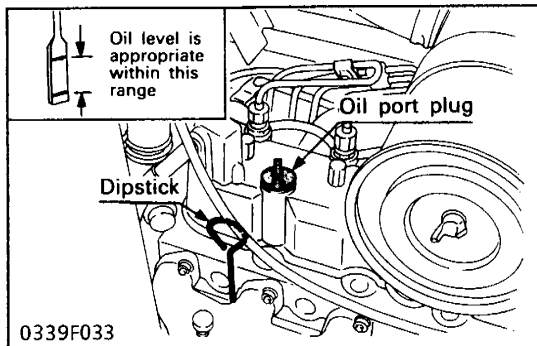

Changing Engine Oil

⚠ CAUTION

- Before changing oil, be sure to stop the engine.

1. Start and warm up the engine for approx. 5 minutes.
2. Place an oil pan underneath the engine.
3. To drain the used oil, remove the drain plug at bottom of the engine and drain the oil completely.
4. Screw in the drain plug.
5. Fill new oil up to upper notch on the dipstick.

■ IMPORTANT

- When using an oil of different manufacturer or viscosity from the previous one, remove all of the old oil. Never mix two different type of oil.
- Use the proper SAE Engine Oil according to ambient temperatures. Refer to "LUBRICANTS AND FLUID" (See page S.G-3)

	B1550, B1750, B1550HST, B1750HST	B2150, B2150HST
Capacity	3.1 ℓ 3.3 U.S. qts 2.7 Imp. qts	4.2 ℓ 4.4 U.S. qts 3.7 Imp. qts

Replacing Engine Oil Filter Cartridge

⚠ CAUTION

- Be sure to stop the engine before changing oil filter cartridge.

1. Remove the oil filter cartridge with the filter wrench.
2. Apply a slight coat of oil onto the cartridge gasket.
3. To install the new cartridge, screw it in by hand. Over tightening may cause deformation of rubber gasket.
4. After the new cartridge has been replaced, the engine oil normally decrease a little. Thus see that the engine oil does not leak through the seal and be sure to read the oil level on the dipstick. Then, replenish the engine oil up to the specified level.

■ IMPORTANT

- To prevent serious damage to the engine, replacement element must be highly efficient. Use only a KUBOTA genuine filter or its equivalents.

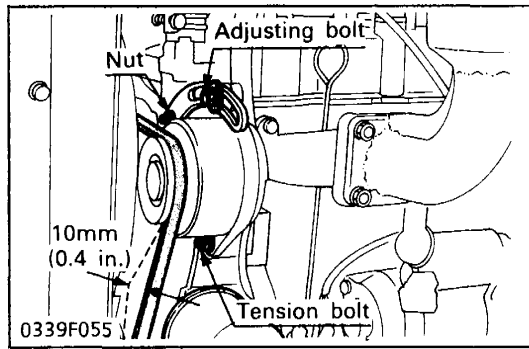
(Initial 50 Hours)**Checking Fan Drive Belt Tension****⚠ CAUTION**

- When making adjustments, park the vehicle on flat ground, apply the parking brake and stop the engine.
- If the fan drive belt becomes loose, the engine may overheat.

1. Check the fan drive belt tension. Moderate belt tension is as follows.

The belt should deflect approx. 10 mm (0.4 in.) when the center of the belt is depressed with a finger force of 98 N (10 kgf, 22 lbs).

2. If no moderate belt tension, loosen the adjusting bolt and tension bolt to stretch the belt and adjust belt tension. After adjustment, securely tighten the their bolts.

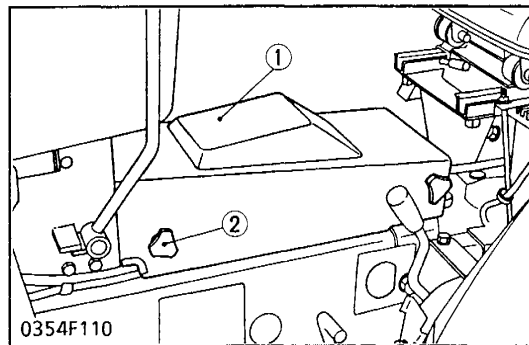
**Replacing Transmission Oil Filter Cartridge only for HST****⚠ CAUTION**

- Be sure to stop the engine before changing the oil filters.

1. Remove the 4 bolts which secure the cover.
2. Remove the oil filter cartridge by using a filter wrench.
3. Lightly tighten the screw (4) by using a screwdriver.
4. Apply a slight coat of oil onto the cartridge gasket.
5. To install the new cartridge, screw it in by hand. Over tightening may cause deformation of rubber gasket.
6. After the new cartridge has been replaced, the transmission fluid level will normally decrease slightly. Make sure that the transmission fluid does not leak through the seal. Check the fluid level.

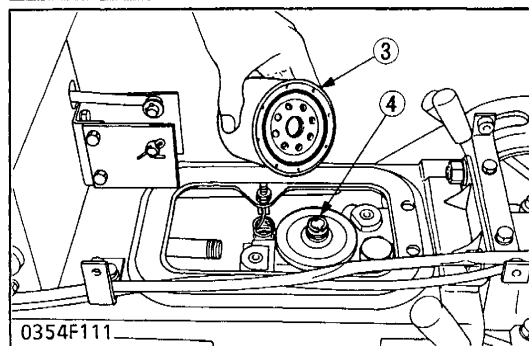

- | | |
|-----------|----------------------|
| (1) Cover | (3) Filter Cartridge |
| (2) Bolt | (4) Screw |

■ IMPORTANT

- To prevent serious damage to the hydraulic system, the replacement filter must be a highly efficient, 10 μ m filter. Use only a genuine KUBOTA filter or its equivalent.
- When using the auxiliary hydraulics, replace the transmission oil filter cartridge after initial 50 service hours.

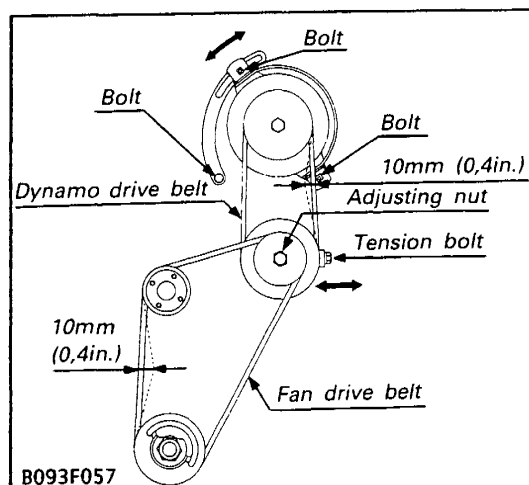
**Checking Fan Drive Belt Tension****and Alternator Drive Belt Tension (Alternator type for Canada)****⚠ CAUTION**

- If the alternator drive belt becomes loose, the battery may not be charged.

1. Check the drive belt tensions. Moderate belt tension is as follows.

The belt should deflect approx. 10 mm (0.4 in.) when the center of the belt is depressed with a finger force of 98 N (10 kgf, 22 lbs).

2. If no moderate belt tension, loosen the bolt and nut and adjust belt tension. After adjustment, securely tighten the bolt and nut.

(2) Check Points of Initial 100 Hours

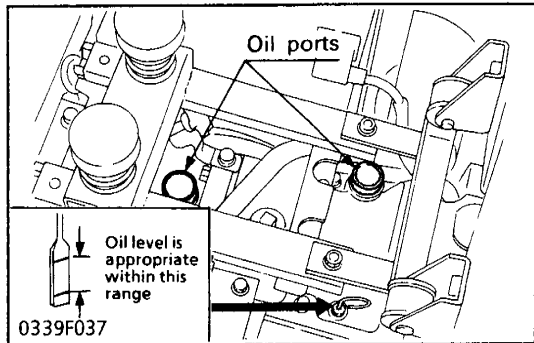
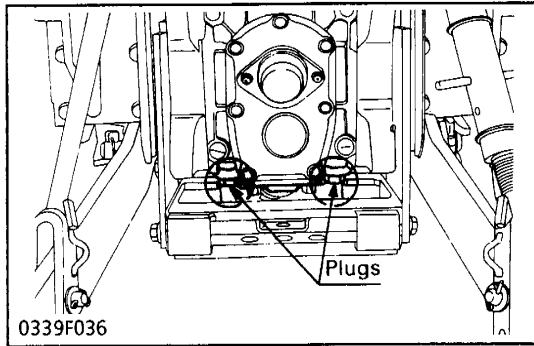

Changing Transmission Fluid

CAUTION

- Be sure to stop the engine before checking and changing the transmission fluid.
1. Place an oil pan underneath the transmission case.
 2. Remove the drain plugs at the bottom of the transmission case.
 3. After draining, screw in the drain plugs.
 4. Fill new oil up to the oil level lies between the two notches.
 5. After running the engine for a few minutes. Stop it and check the oil level again, if low, replenish new oil.

Transmission oil capacity	B1550, B1750	B1550HST, B1750HST	B2150, B2150HST
	12 ℓ 12.7 U.S. qts. 10.6 Imp. qts.	13.5 ℓ 14.3 U.S. qts. 11.9 Imp. qts.	18 ℓ 19 U.S. qts. 15.8 Imp. qts.

IMPORTANT

- Use only multi-grade transmission fluid. Use of other oils may damage the transmission or hydraulic system. Refer to "LUBRICANTS AND FLUID" (See page S.G-3).
- Never work the tractor immediately after changing the transmission fluid. Keeping the engine at medium speed for a few minutes to prevents damage to the transmission.

Cleaning Transmission Strainer

Since the fine filings in the oil could impair the component parts of hydraulic system which is precision built to withstand high pressure, the suction line end is provided with an oil strainer. When changing the transmission fluid, disassemble and rinse the strainer with kerosene to completely clean off filings. For reassembly, be careful not to damage the parts.

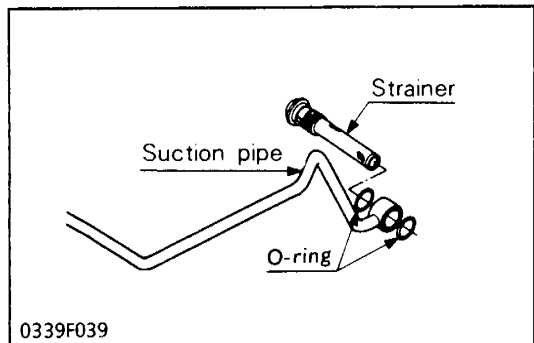
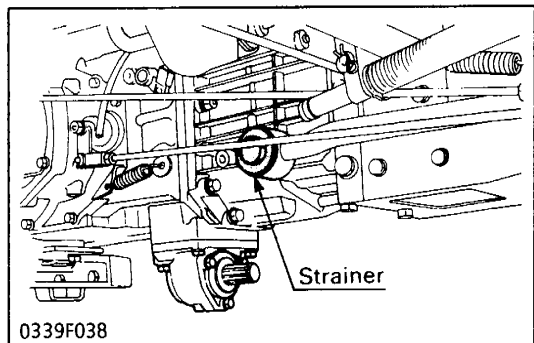

(3) Check Points of Every 100 Hours

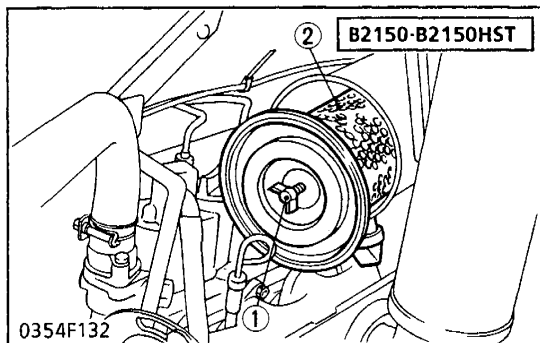
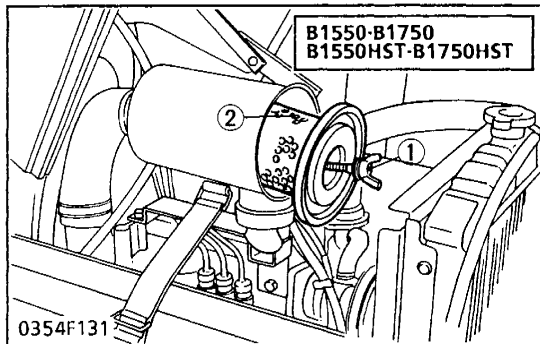
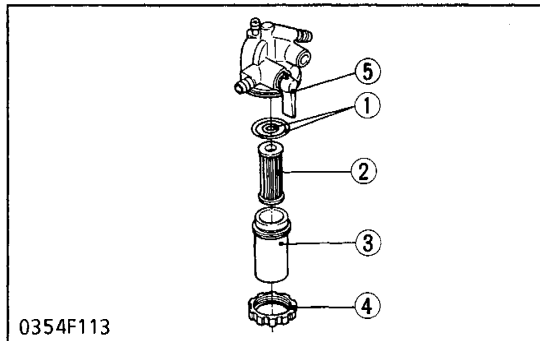
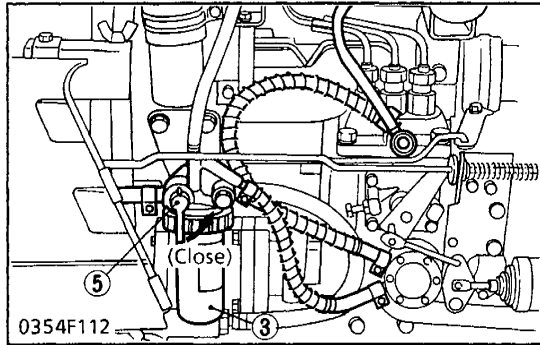

Changing Engine Oil

Refer to page S.G-6.

Cleaning Fuel Filter

When operation period reaches approx. 100 hours, clean the fuel filter.

This job should not be done in the field, but in a clean place so as to prevent dust from entering fuel system.

1. Unscrew the wing bolt and knob bolt which fasten the engine cover RH, and remove the cover.
2. Close the fuel filter bowl cock.
3. Unscrew and remove the screw ring, and rinse the inside with kerosene.
4. Take out the element and dip it in the kerosene to rinse.
5. After cleaning reassembling the fuel filter, keeping out dust and dirt.
6. Bleed the injection pump. (Refer to S.G-20, 21)

■ IMPORTANT

- If dust and dirt enter the fuel, the fuel pump and injection nozzle are subject to wear. To prevent this, be sure to clean the fuel filter bowl periodically.

- | | |
|-----------------|----------------|
| (1) O-ring | (4) Screw Ring |
| (2) Element | (5) Fuel Cock |
| (3) Filter Bowl | |

Checking and Cleaning Air Cleaner Element

1. The air cleaner uses a dry element, never apply oil.
2. Grasp the evacuator valve of the air cleaner to let the dust to fall once a week, but everyday if working conditions are especially dusty.
3. Do not touch the filter element except in cases where cleaning is required.
4. When cleaning the element, refer to the instructions attached.
5. If the element is stained with carbon or oil, replace the filter.
6. Change the element once a year or every 6 times of cleaning (Rinsed with water).

■ IMPORTANT

- Do not run the engine with filter element removed.

- | | |
|----------|-------------|
| (1) Bolt | (2) Element |
|----------|-------------|

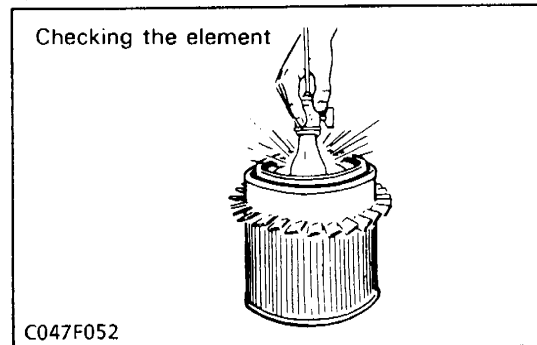
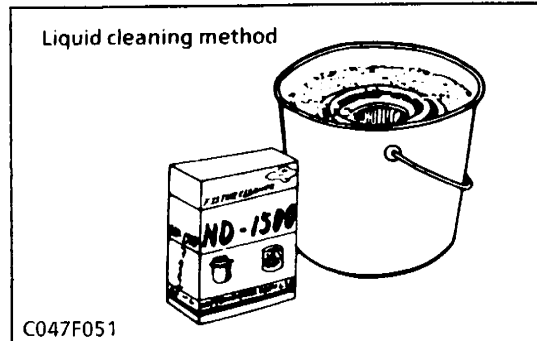
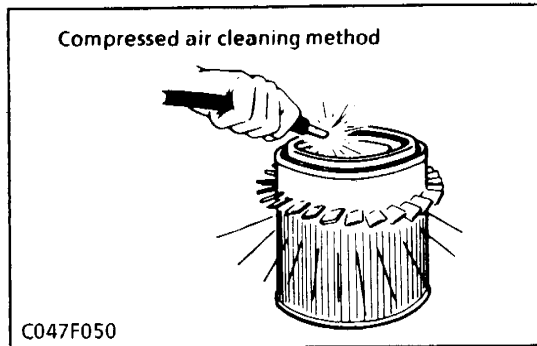
(Every 100 Hours)**Cleaning Air Cleaner Element**

1. To clean the element, use clean dry compressed air on the inside of the element. Air pressure at the nozzle must not exceed 205 kPa (2.1 kgf/cm², 30 psi). Maintain reasonable distance between the nozzle and the filter.
2. To wash the element, use KUBOTA Filter cleaner, Donaldson ND-1500 Filter Cleaner or equivalent, which is especially effective on oily and soot-laden filters.
To use: Dissolve KUBOTA Filter Cleaner in a concentrated solution of cold water. When granules are thoroughly mixed, add water to make a solution equivalent to 15 g KUBOTA Filter Cleaner for each 1ℓ (1 quart) of water. (2 oz KUBOTA Filter Cleaner for each 1 gallon of water.) Allow element to soak 15 minutes. Then agitate element to dislodge loosened dust-rinse in clear water-allow element to dry.

(Every 100 Hours)

Greasing the Following Points

- Apply a small amount of grease to following points.

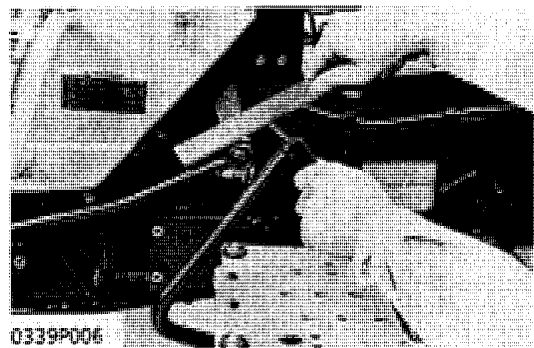
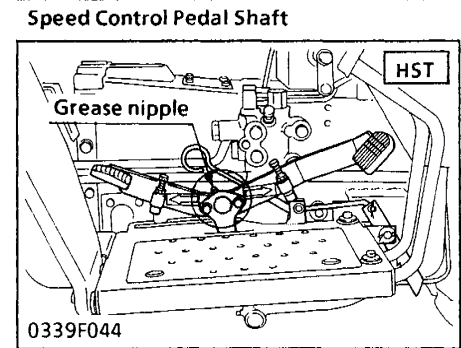
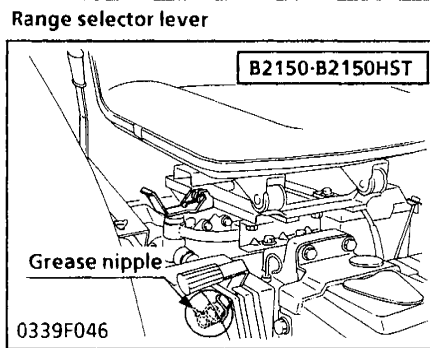
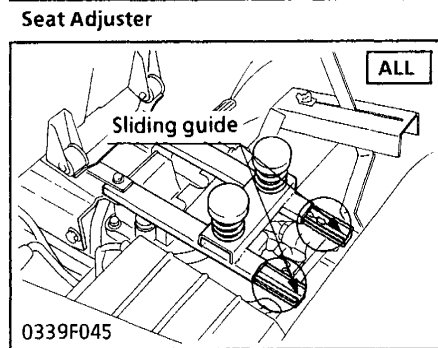
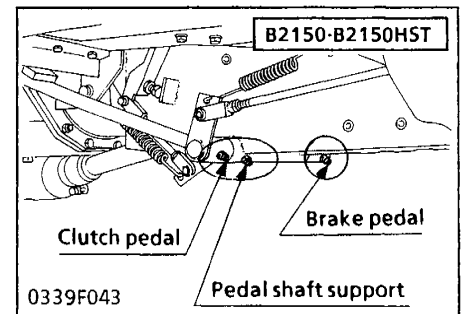
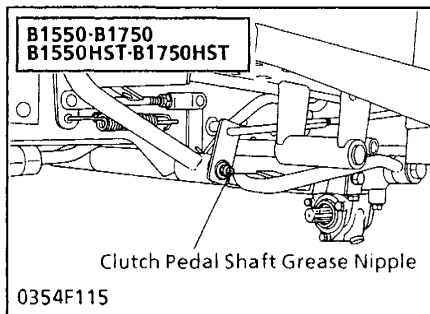
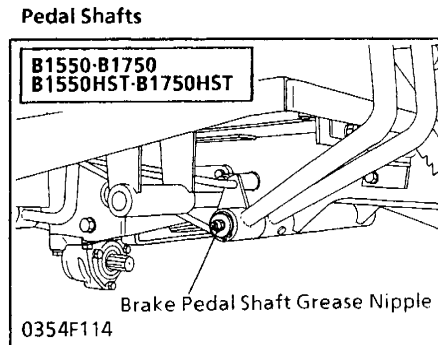
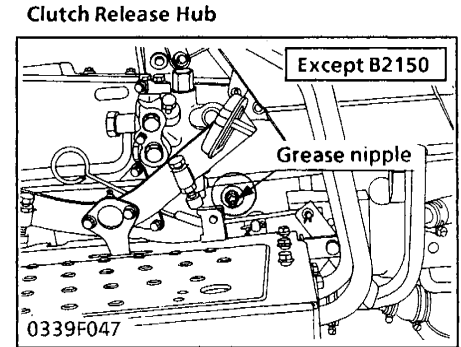
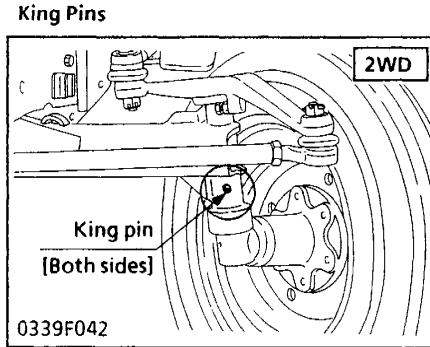
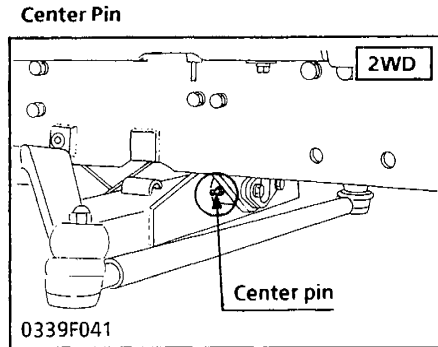

Checking Clutch Pedal Play

1. Depress the clutch pedal by hand, and measure the amount of pedal movement.
2. If the measurement is not within the factory specifications, adjust the play by changing the length of rod (1).
3. After adjusting it, be sure to keep the following distance for stopper bolt.
4. After adjusting them, try to start engine. If no start, check the safety switch setting position.

(Every 100 Hours)

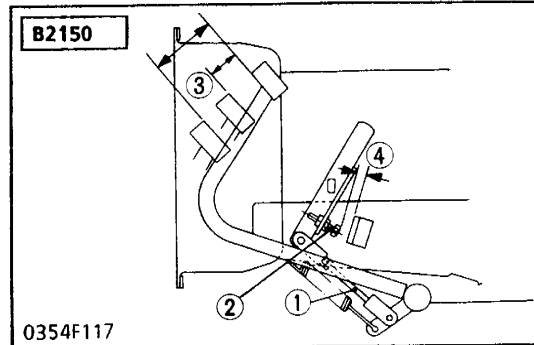
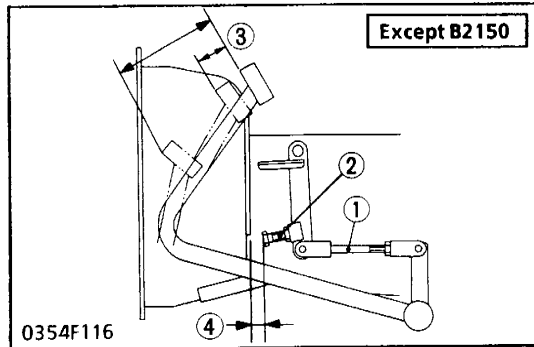

Checking Clutch Pedal Play (Continued)

	Model	Factory spec.
Clutch pedal play	All	20 to 30 mm 0.8 to 1.2 in.
Stopper Bolt Distance	B1550 B1750	11 to 13 mm 0.43 to 0.51 in
	B1550HST.B1750HST	
	B2150	16 to 17 mm 0.63 to 0.67 in.
	B2150HST	11 to 12 mm 0.43 to 0.47 in.

- (1) Rod
- (2) Stopper Bolt
- (3) Pedal Play
- (4) Stopper Bolt Distance

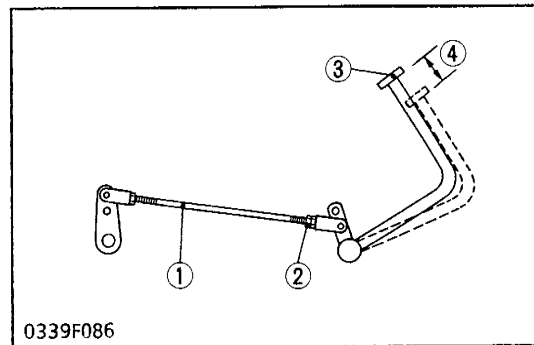

- (1) Rod
- (2) Lock Nut
- (3) Brake Pedal
- (4) brake Pedal Play

Checking Brake Pedal Play

- Depress each pedal by hand and measure the amount of each pedal movement.
- If the measurement is not within the factory specifications, adjust the play by changing the length of rod. Keep the difference between the right and left pedal plays be less than 4 mm (0.16 in.).

Brake pedal play	Factory spec.	20 to 30 mm 0.8 to 1.2 in.
------------------	---------------	-------------------------------

IMPORTANT

- After adjustment, interlock the right and left brake pedals and tighten the lock.

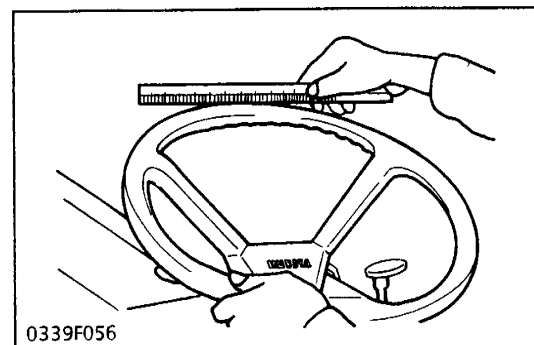

Checking Steering Wheel Play

- Turn the front wheels straight ahead.
- Measure the play with a rule.
- If the play is not within the factory specifications, remove the cap nut (1) loosen the lock nut (3) and turn the adjusting screw (2) with a screwdriver to adjust.

Steering wheel play	Manual steering	Factory spec.	5 to 30 mm 0.2 to 1.2 in.
	Power steering	Factory spec.	Less than 30 mm 1.2 in.

- (1) Cap Nut
- (2) Adjusting Screw
- (3) Lock nut



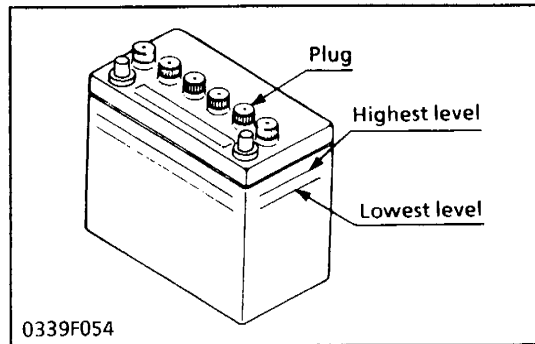
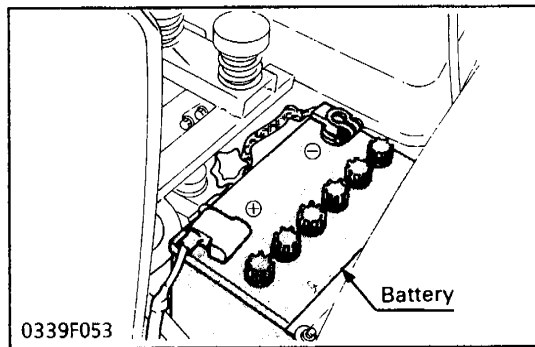

Checking Battery

⚠ CAUTION

- Never take off the battery cap while the engine is running. Keep electrolyte away from eyes, hands and clothes. If you are spattered with it, wash it away completely with water as soon as possible.
- After the battery is activated, hydrogen and oxygen gases in the battery are very explosive. Keep open sparks and flames away from the battery at all times, especially when charging the battery.
- When connecting the battery, do not reverse the polarities. Connection with reverse polarities cause troubles to the battery and electrical system in the vehicle.
- When disconnecting the cable from the battery, start with the negative terminal first. When connecting, start with the positive terminal first. Reversing the steps may cause short-circuiting, should a metallic tool touch the terminals.

1. Mishandling the battery shortens the service life and adds to maintenance costs. Be sure to handle it correctly so that it will develop its full potential performance.
2. If the battery is weak, the engine is difficult to start and the light become dim. It is important to check the battery daily and recharge before such trouble occurs.
3. The water in the electrolyte evaporates during recharging. Liquid shortage damages the battery and excessive liquid spills over and damages the body. If low, be sure to fill up the battery with distilled water only.
4. To charge the battery, connect the battery positive terminal to the charger positive terminal and the negative to the negative, then recharge in the standard fashion.
5. A boost charge is only for emergencies. It charges partially the battery at a high rate and in a short time. When using a boostcharged battery, it is necessary to recharge the battery as early as possible after the operation has been finished. Failure to do this extremely affects the service life.

(Reference)

- For recharging, see page S.G-17.

(Every 100 Hours)

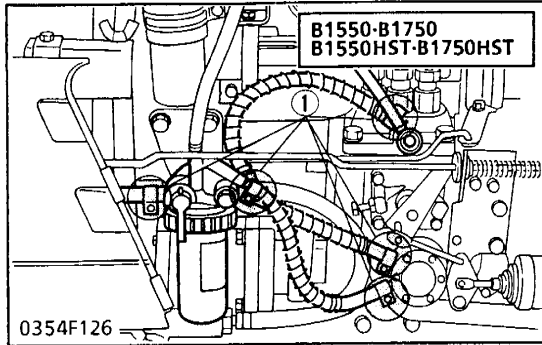

(1) Fuel Line Clamps

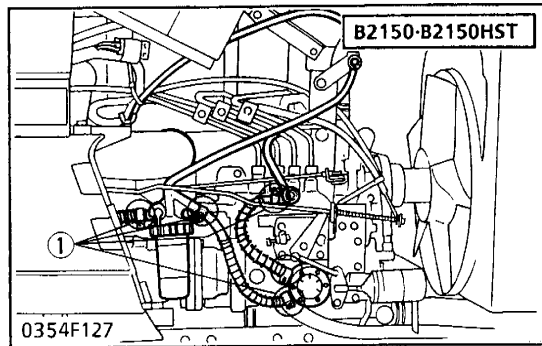

Checking Fuel Line

CAUTION

- Stop the engine when attempting the check and change prescribed below.
- Remember to check the fuel line periodically. The fuel line is subject to wear and aging, fuel may leak out onto the running engine, causing a fire.

Although checking the fuel pipe connections is recommended every 100 service hours, it should be done every 6 months, if operation does not exceed 100 hours in 6 months.

1. If the clamp is loose, apply a slight coat of lubricant onto the threads and securely retighten it.
2. The fuel line is made of rubber and ages regardless of period of service. Replace the fuel pipe together with the clamp every two years and securely tighten.
3. However if the fuel pipe and clamp are found damaged or deteriorated earlier than two years, then change or remedy.
4. After the fuel line and clamp have been changed, bleed the fuel system.

IMPORTANT

- When the fuel line is disconnected for change, close both ends of the fuel line with a piece of clean cloth or paper to prevent dust and dirt from entering. Entrance of dust and dirt causes malfunction of the fuel injection pump. In addition, particular care must be taken not to admit dust and dirt into the fuel pump.

(4) Check Point of Every 200 Hours

Replacing Engine Oil Filter Cartridge

See page S.G-6.

Checking Radiator Hose and Hose Clamp

1. Checking radiator hose clamp tightness is specified about every 150 service hours, but every 6 months is all right so long as service duration does not exceed 150 hours in 6 months.
2. If the clamp is loose, apply a slight coat of oil and securely retighten.
3. The radiator hose is made from rubber and tends to age. It must be changed every two years. Also change the clamp and securely tighten.

- | | |
|---------------------|-----------------|
| (1) Radiator Hose 1 | (3) Return Hose |
| (2) Radiator Hose 4 | (4) Drain Hose |

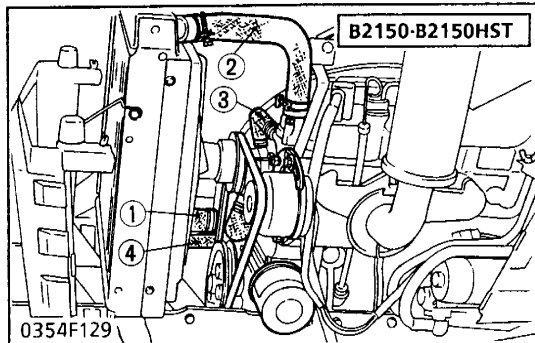
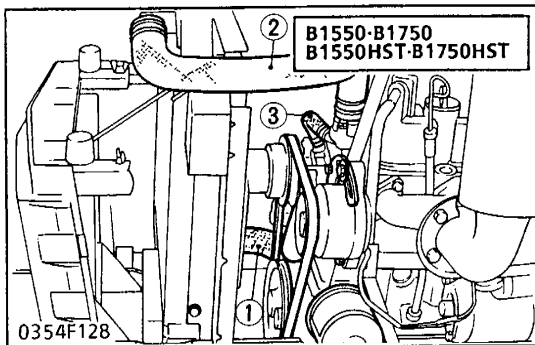

(Every 200 Hours)

Checking Fan Drive Belt Tension

See page S.G-7.

(5) Check Point of Every 300 Hours

Changing Transmission Fluid

See page S.G-8.

Replacing Transmission Oil Filter Cartridge only for HST

See page S.G-7.

Changing Front Axle Differential Case Oil (4WD)

1. Remove the drain and filling port plug. After draining, replace the drain plug and fill with new oil.

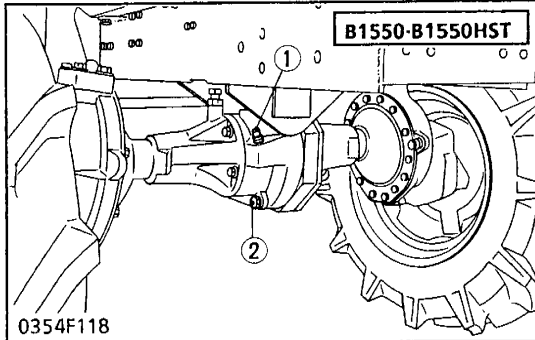

Front axle differential gear case oil capacity	B1550 B1550HST	B1750 B1750HST	B2150 B2150HST	Bi-speed turn
	0.5 ℓ 0.5 U.S. qts. 0.5 Imp. qts.		1.5 ℓ 1.6 U.S. qts. 1.30 Imp. qts.	2.5 ℓ 2.6 U.S. qts. 2.2 Imp. qts.

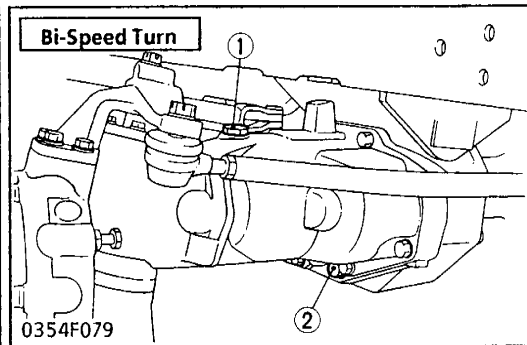
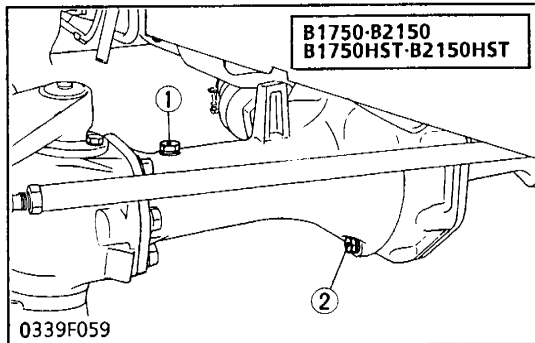

(1) Filling Port Plug
(2) Drain Plug

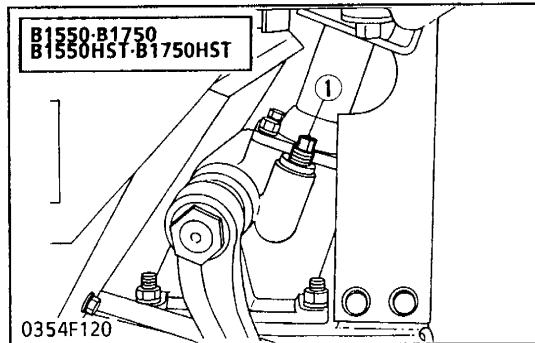

Steering Gear Box Oil (Manual Steering)

1. If the oil is insufficient, fill with gear lube up to the oil inlet port (1).

Steering gear box oil capacity	0.2 ℓ 0.2 US qts 0.2 Imp. qts
--------------------------------	-------------------------------------

(1) Inlet Port

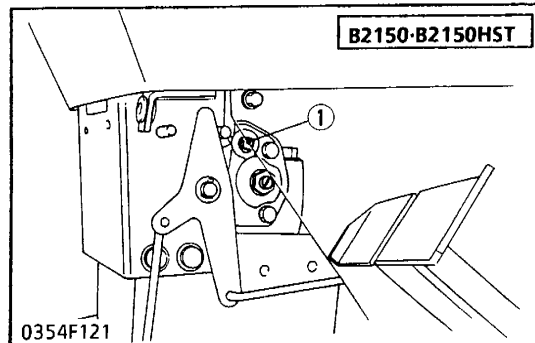

(Every 300 Hours)

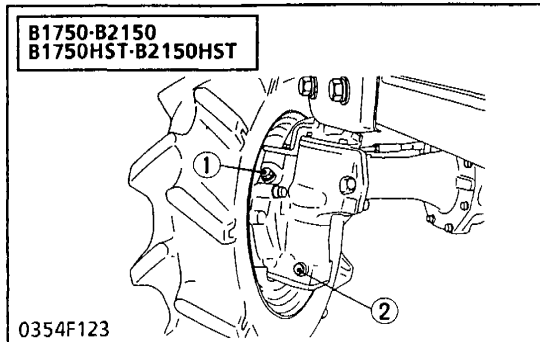
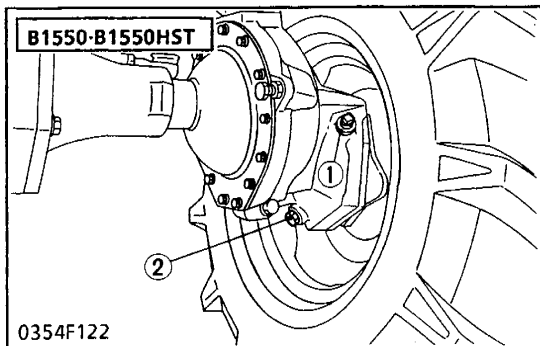

Changing Front Axle Gear Case Oil (4WD)

1. Remove the drain and filling port plugs. After draining, replace the drain plug and fill with new oil.

Front axle differential gear case oil capacity (Right or Left)	B1550 B1550HST	B1750, B2150 B1750HST, B2150HST
	0.15 ℓ 0.16 US qts 0.13 Imp qts	0.5 ℓ 0.5 US qts 0.5 Imp qts

(1) Filling Port Plug (Both sides) (2) Drain Plug (Both sides)

Cleaning Transmission Strainer

See page S.G-8.

(6) Check Point of Every 400 Hours

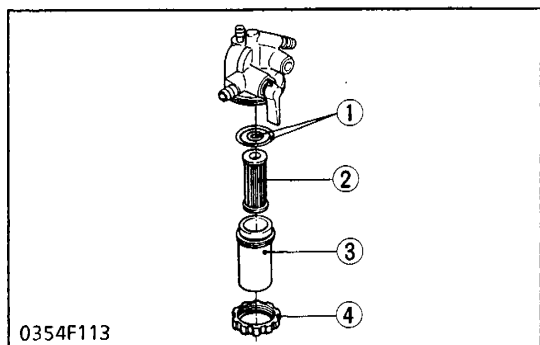

Changing Fuel Filter Element

1. The fuel filter element should be replaced every 400 hours. See page S.G-9.

(1) O-ring (3) Filter Bowl
(2) Element (4) Screw Ring

(7) Check Point of Every 600 Hours, Every Year or Every 6 Times of Cleaning

Replacing Air Cleaner Element

See page S.G-9.

(8) Check Point of Every One or Two Months

Recharging Battery

1)-1 Slow Charging

1. Add distilled water if electrolyte is insufficient.
The level of electrolyte should be slightly lower than the specified level to prevent overflow while charging.
2. Connect battery and charging unit properly.
3. Charging current must be 1/20 to 1/10 of battery electric capacity.
4. Electrolyte temperature must not exceed 45°C (113°F) during charging. If it exceeds 45°C (113°F), lower the charging current or stop charging for a while.
5. During charging, electrolyte generates gas. Therefore, remove all port caps.
6. Charging time

$$\text{Charging time} = \frac{\text{Discharging current rate (Ah)}}{\text{charging current (A)}} \times (1.2 \text{ to } 1.5)$$

7. When charging different capacity batteries at the same time, charging current must be set for the smallest capacity battery.

1)-2 Quick Charging

1. Determine the proper charging current and charging time with the tester attached to the quick charger.
2. Determine the proper charging current as 1/1 of the battery capacity. If the battery capacity exceeds 50Ah, consider 50A as the maximum.

■ PRECAUTION FOR OPERATING A QUICK CHARGER

- Operation with a quick charger differs according to the type. Consult the instruction manual and use accordingly.

(9) Check Point of Every Year

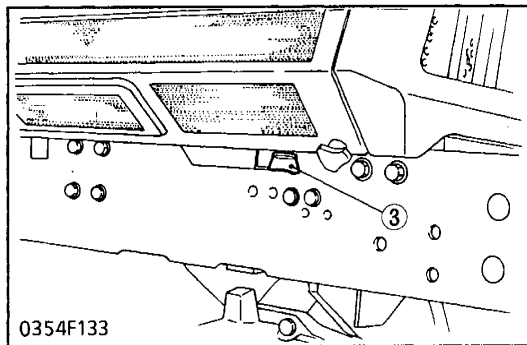
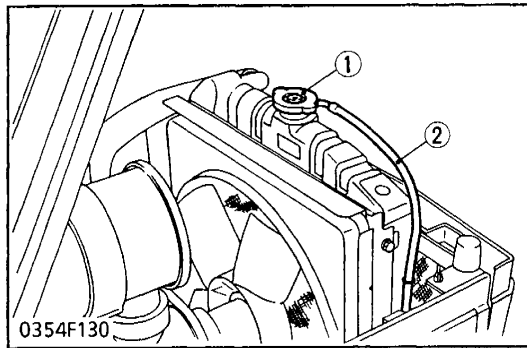

- (1) Radiator Cap (3) Drain Cock
(2) Overflow Pipe

Changing Antifreeze and Coolant

⚠ CAUTION

- Before changing the coolant, be sure to stop the engine.
- Never open the pressure cap while the engine is running under heavy loads or immediately after the engine has stopped. Otherwise, hot water may spray out, scalding the operator.
So make it a habit to wait for about 10 minutes before opening the cap.
A full tank of coolant is enough for one day's work. Make it a rule to check the level of the coolant prior to operation.

1. To drain the used coolant, open the radiator drain cock and remove radiator cap. The radiator cap must be removed to completely drain the radiator.
2. Be sure to close the pressure cap securely. If the cap is loose or improperly closed, water may leak out and the engine could overheat.
3. Radiator should be filled with 50/50 part of antifreeze and water at all times as recommended by the antifreeze manufacturer. The antifreeze contains a corrosion inhibitor and will allow a higher operating temperature in the radiator during the hot season.
4. Don't use an antifreeze and scale inhibitor at the same time.

	B1550 B1550HST	B1750 B1750HST	B2150 B2150HST
Coolant capacity	2.9 ℓ	3.5 ℓ	3.9 ℓ
	3.1 U.S. qts. 2.6 Imp. qts.	3.7 U.S. qts. 3.1 Imp. qts.	4.1 U.S. qts. 3.4 Imp. qts.

(Every Year)**KUBOTA Scale Inhibitor No. 11**

- The KUBOTA Scale Inhibitor No.11 prevents scale formation in the cooling water. Scale which builds up in either hard or soft water, sharply reduces cooling efficiency.
- The Scale Inhibitor is effective for 3 months so complete change of cooling water must be done every 3 months.

Antifreeze

If the cooling water freezes, the engine cylinder and radiator may crack. In cold weather before the temperature drops below 0°C(32°F), drain out the water or add a proper amount of antifreeze when the tractor is shut down.

- There are two types of antifreeze solutions, permanent type (PT) and semi-permanent type (SPT). For the Kubota Engine, be sure to use the permanent type.
- When antifreeze is used for the first time, fill and drain clean water two or three times so as to completely clean the inside of the radiator.
- Mix the antifreeze and the water, then pour the mixture into the radiator.
- When the cooling water mixed with antifreeze decreases due to evaporation, replenish with water only. If loss has been due to leaking, add water and antifreeze mixture with the same mix ratio as the original preparation.
- Antifreeze solutions absorb moisture, so be sure to securely close the container after use.
- Antifreeze and water should be changed every year.
- Do not use an antifreeze and a scale inhibitor at the same time. This may cause sludge to form adversely affecting the engine parts.

Correcting Water Leakage

- A small water leak can be eliminated with the Kubota Radiator Cement No. 40 or equivalent.

Cleaning Radiator

Before changing antifreeze and coolant, clean the water cooling system (radiator etc.).

1. The water cooling system should be cleaned on the following occasions:
 - Every year service hours.
 - When adding an antifreeze solution.
 - When changing from water containing antifreeze to pure water.
2. When cleaning the water cooling system, the KUBOTA Scale Inhibitor No. 20 is recommended to effectively wash away the scale built-up.

(10) Check Point of Every 2 Years**Changing Battery**

Changing battery, if necessary.
See page S.G-13.

Changing Radiator Hose and Clamp

See page S.G-14.

Changing Fuel Line

See page S.G-14.

Changing Hydraulic Hose and Clamp

1. The hydraulic hose is made from rubber and tends to age. It should be changed every 2 years. Together change the clamps and securely tighten.

(11) Check Point of Every 800 Hours

Checking Valve Clearance

Valve clearance IN. and EX. (Cold)	Factory spec.	0.145 to 0.185 mm 0.0057 to 0.0073 in.
---------------------------------------	---------------	---

(12) Check Point of Daily

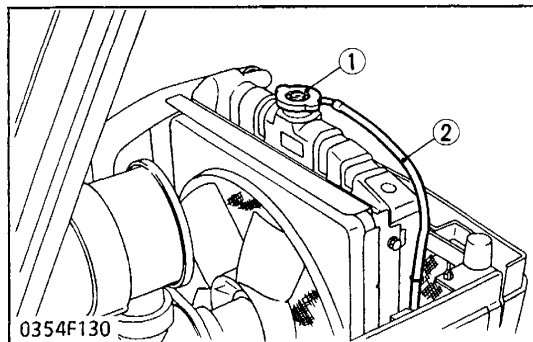
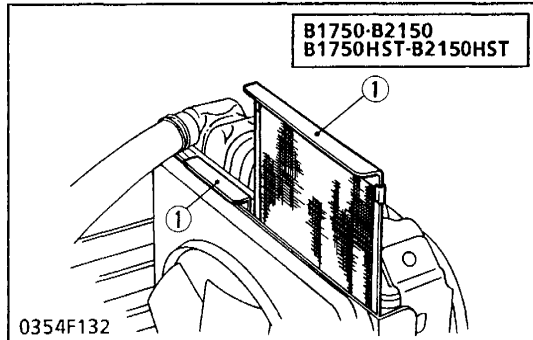
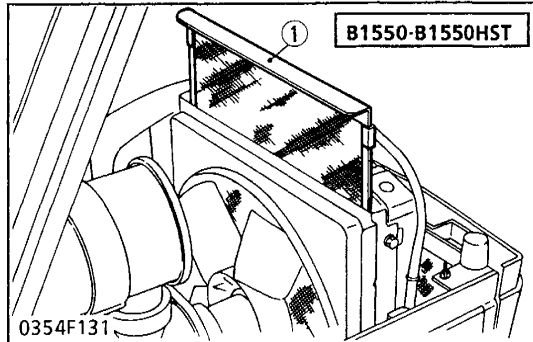

Checking Radiator Screen

Checking Oil Cooler Exterior (Only for HST)

Daily or every 5 hours of operation, check to be sure the radiator net, radiator core and oil cooler core are clean. Dirt or chaff to the radiator net, radiator core, or oil cooler core decrease cooling performance.

1. In that case, detach the net and remove all the foreign materials from them.
2. Remove the dust from between the fins and the tube.
3. Tighten the fan drive belt as necessary. For this, refer to page S.G-7, 15.
4. If scale forms in the tube, clean with KUBOTA Scale Inhibitor.

(1) Radiator Screen

Checking Coolant Level

1. Remove the radiator pressure cap and check to see that the coolant level is just below the port. If low, add clean soft water and antifreeze.

■ IMPORTANT

- Use clean, fresh soft water to fill the radiator.
- Securely tighten the radiator cap.

(1) Radiator Cap

(2) Overflow Pipe

Checking Oil and Fuel Level

1. Check the engine oil level.
2. Check the transmission oil level.
3. Check the fuel level.

Checking Tire Pressure

1. Check the tire pressure.

(13) Fuel

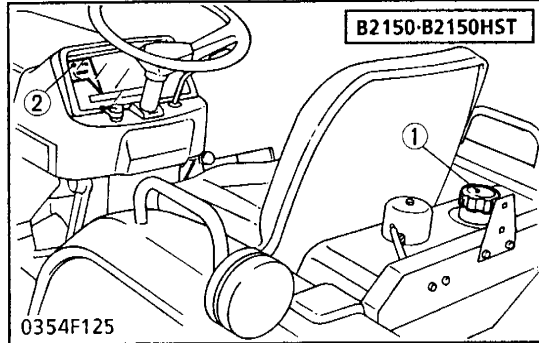
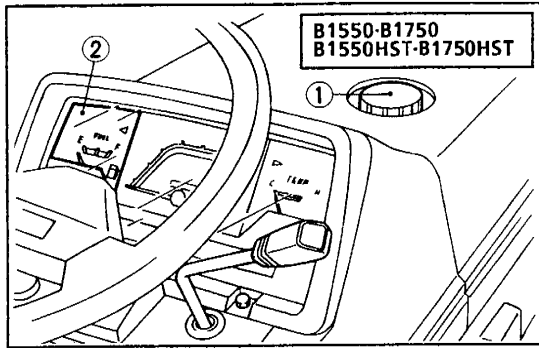

(1) Fuel Tank Cap (2) Fuel Gauge

0354F125

Checking and Refueling

CAUTION

- Stop the engine before adding fuel. Keep away from sparks and flames.

IMPORTANT

- Use only diesel fuel.
1. Check the fuel level. Take care that the fuel level does not fall under the prescribed lower limit.
 2. Use No.2-D diesel fuel.
 3. Use No.1-D diesel fuel if the temperature is below - 10°C (- 15°F).

Fuel tank capacity	B1550, B1750 B1550HST, B1750HST	18 ℓ 4.8 U.S. gal. 4.0 Imp. gal.
	B2150, B2150HST	28 ℓ 7.4 U.S. gal. 6.2 Imp. gal.

IMPORTANT

- Always use a strainer in refueling to prevent fuel injection pump from contamination.
- Once the fuel tank becomes empty, air is admitted to the fuel system, in such case, it will be necessary to bleed the fuel system before an engine will start.

Bleeding Fuel Lines

Air must be removed:

- When the fuel filter and lines have been removed.
- When fuel tank has been completely empty.
- After the vehicle has not been used for a long period of time.

Bleeding procedure is as follows:

CAUTION

- Never bleed the fuel system when the engine is hot.

[B1550, B1750, B1550HST, B1750HST]

1. Fill the fuel tank with fuel, and open the fuel cock.
2. Open the air vent plug on the fuel injection pump.
3. Pull the engine stop knob back completely to prevent the engine from starting while turning the key to rotate the engine for about 10 seconds.

CAUTION

- For the above procedure, pull out the engine stop knob before engaging the starter.

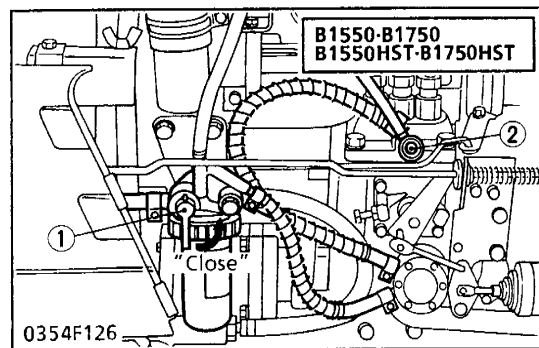

(1) Fuel Cock (2) Air Vent Plug

0354F126

4. Close the air vent plug.

IMPORTANT

- Always close the air vent plug except for bleeding fuel lines. Otherwise, engine runs irregularly or stalls frequently.

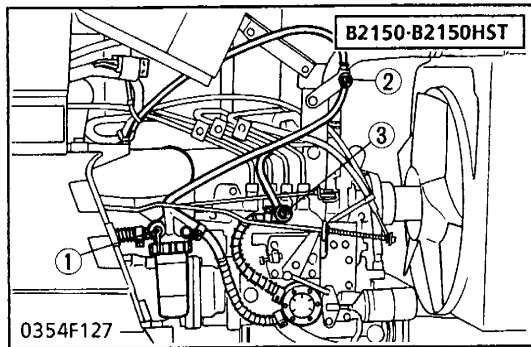

(1) Fuel Cock (2) Air Vent Plug 1 (3) Air Vent Plug 2

[B2150, B2150HST]

1. Open the fuel cock.
2. Open the air vent plug 1 and the air vent plug 2.
3. Fill fuel tank at least half full.
4. Close the air vent plug 1.
5. Refill the fuel tank.
6. Start the engine for about 1 minute and then stop it.
7. Close the air vent plug 2.

■ IMPORTANT

- Always close the air vent plugs except for bleeding fuel lines. Otherwise, engine will run irregularly or stall frequently.

(14) Original Charge of Dry Type Battery

⚠ CAUTION

- After the battery is activated, hydrogen and oxygen gases in the battery are very explosive. Keep open sparks and flames away from the battery at all times, especially when charging the battery.
- Keep electrolyte away from eyes, hands and clothes if your are spattered with it, wash it away completely with water.

■ PRECAUTION BEFORE USE

- This battery is delivered in dry-charged condition without electrolyte. Do not take off sealing tapes, films and caps just until ready for filling acid.
- The duration of dry-charged efficiency shall be decreased in proportion to the period of time elapsed after shipment and during storage. To secure satisfactory service and long life of the battery, it is necessary for the battery to be charged for reasonable period of time.

1. Remove vent plugs and discard temporary sealing cardboards and tapes.
2. Fill each cell with electrolyte having a specific gravity given in Table 1 up to highest level marked on the battery case side.

Table 1

	AIR TEMPERATURES	
	TEMPERATURE Ordinarily below 20°C (68°F)	TROPICAL Frequently above 20°C (68°F)
sp.gr. of Electrolyte for Filling	1.260	1.240
sp.gr. of Electrolyte when fully charged	1.260 to 1.275	1.240 to 1.255

3. After standing 2 or 3 hours correct the electrolyte to former level.
4. Connect positive terminal (+) of battery, with positive terminal of D.C. charging unit, and negative terminal (-) with negative terminal.
5. Batteries are preferably charged by current showed in Table 2. Keep vent plugs removed during charging.

Table 2

TYPE	Volts (V)	Number of plate per cell	Capacity at 20 H.R. (Ah)	Volume of Electrolyte	Normal Charging Rate (A)
NS70	12	11	65	4.5 ℓ 4.8 U.S.qts 4.0 Imp.qts	6

6. Check temperature of electrolyte, if it reaches 40°C (105°F) lower the charging rate. When temperature too high, reduce charging rate and charge for a proportionately longer period.
7. If the tractor is stored after original charge, periodically recharge as shown in Table 3. A battery is fully charged when the cells are all gassing freely and the specific gravity ceases to rise for three consecutive readings taken at hour intervals. Specific gravity shall then be adjusted to showed in Table 1.

Table 3

Period of storage from manufactured	Freshing charge
0 to 6 months	about 5 hours
6 to 12	10
over 12	30

8. Check electrolyte level two hours after charging is finished and correct it if necessary by adding distilled water.

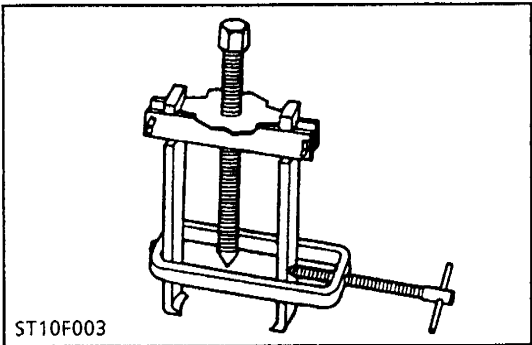
[8] SPECIAL TOOLS**(1) Special Tools for Engine**

ST10F003

Special Use Puller Set

Code No.: 07916-09032

Application: Use exclusively for pulling out bearing, gears and other parts with ease.

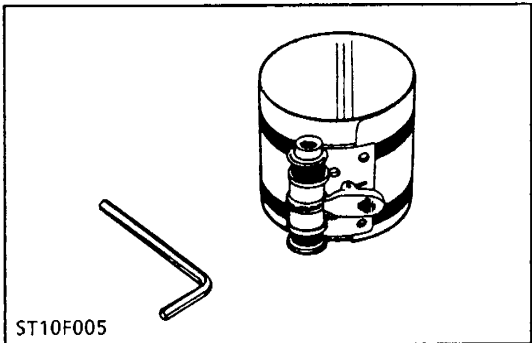

ST10F005

Piston Ring Compressor

Code No.: 07909-32111

Application: Use exclusively for pushing in the piston with ease.

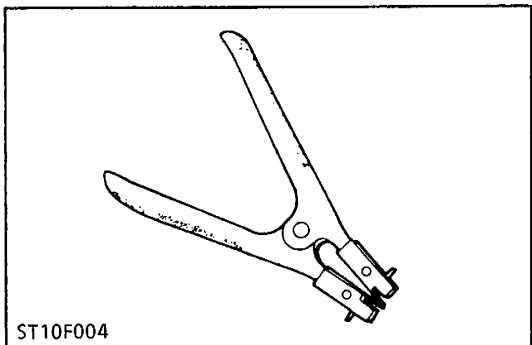

ST10F004

Piston Ring Tool

Code No.: 07909-32121

Application: Use exclusively for removing or installing the piston ring with ease.

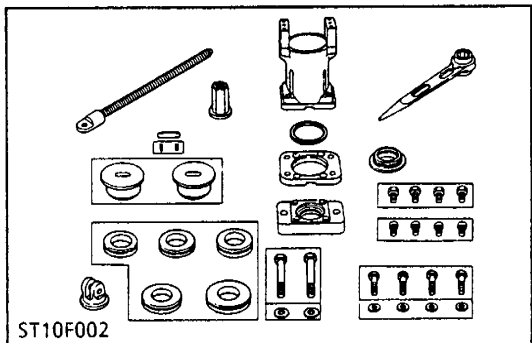

ST10F002

Dry Liner Changer - II

Code No.: 07916-33081

Application: A puller for pulling out the dry liner. It combines with a presser for pushing in the dry liner.

*Dry Liner Changer (07916-30043) is available. Adaptor (Dia. 64 mm) (07916-32981) and centering adaptor (07916-32991) are added to Dry Liner Changer II .

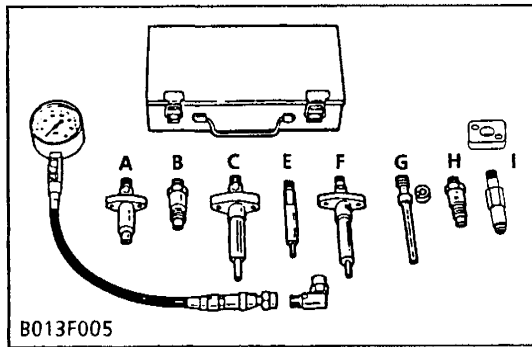

Diesel Engine Compression Tester (Including Adaptor G)

Code No.: 07909-30207 (Assembly)
 07909-30934(A to F)
 07909-31211 (E and F)
 07909-31251 (G)
 07909-31231 (H)
 07909-31271 (I)

Application: Use for measuring diesel engine compression pressure.

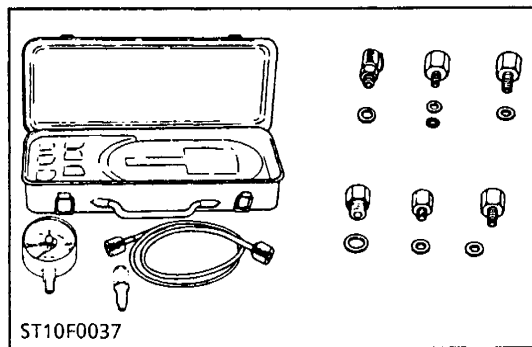

Oil Pressure Tester

Code No.: 07916-32032

Application: Use to measure lubricating, for all kinds of diesel engines.

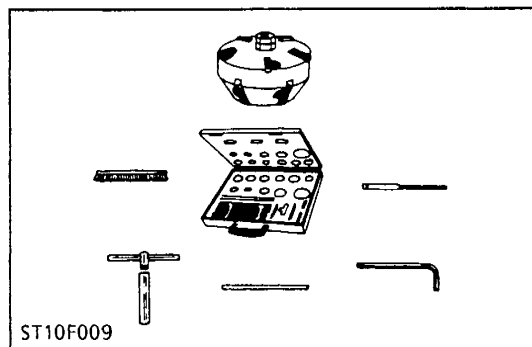

Valve Seat Cutter

Code No.: 07909-33102

Application: Use to reseal valves.

Angle: 0.785 rad. (45°)

0.262 rad. (15°)

Diameter: 28.6 mm (1.126 in)

31.6 mm (1.244 in)

35.0 mm (1.378 in)

38.0 mm (1.496 in)

41.3 mm (1.626 in)

50.8 mm (2.000 in)

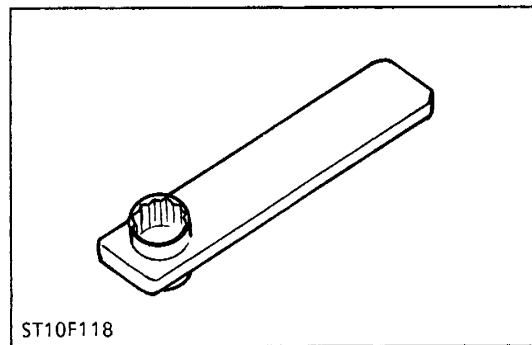

Socket Wrench 29

Code No.: 07916-31841

Application: Use to take off and to fix the crankshaft nut of diesel engine.

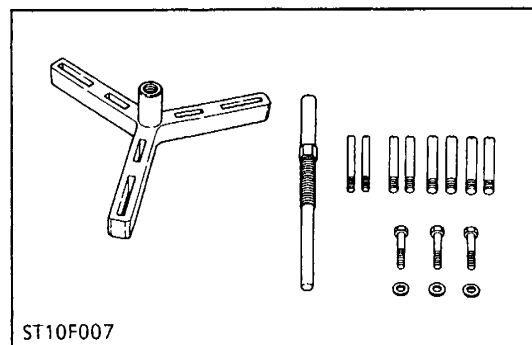

Flywheel Puller (For vertical type diesel engines)

Code No.: 07916-32011

Application: Use exclusively to take off the flywheel of all vertical type diesel engines safely and easily.

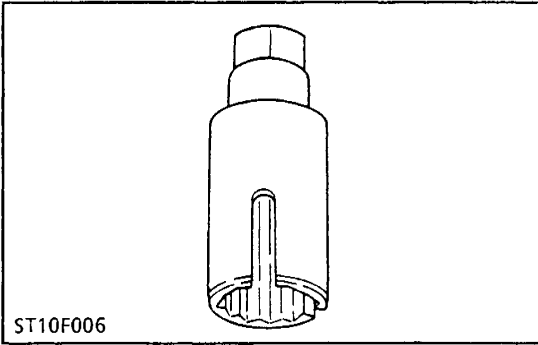
**Nozzle Holder Socket Wrench 27**

Code No.: 07916-30841

Application: Use to unfasten and fasten the screw type nozzle holders of Z,D,V and S series diesel engine.

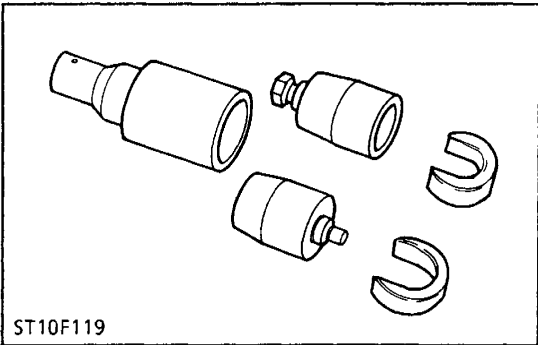
**Crank Sleeve Setter**

Code No.: 07916-33011

Application: Use to fix the crankshaft sleeve of the diesel engine.

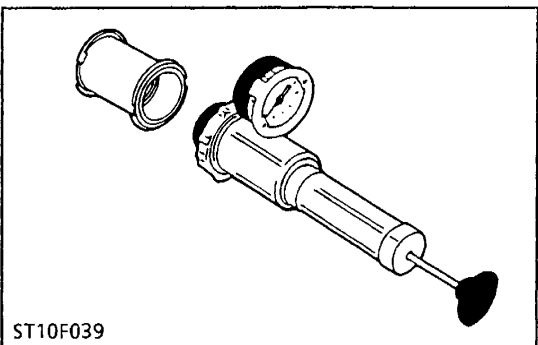
**Radiator Tester**

Code No.: 07909-31551

Application: Use to check of radiator cap pressure, and leaks from cooling systems.

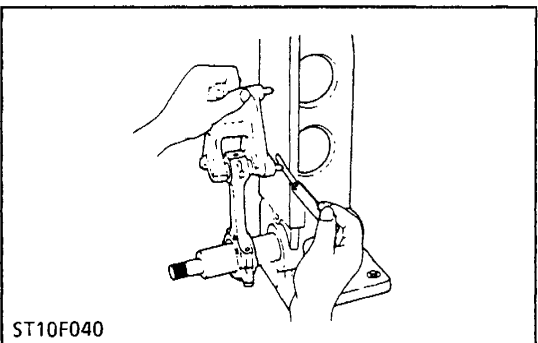
**Connecting Rod Alignment Tool**

Code No.: 07909-31661

Application: Use to check the connecting rod alignment.

Applicable range: Connecting rod large end I.D. 30 to 75 mm (1.18 to 2.95 in. dia.)

Connecting rod length

65 to 330 mm (2.56 to 12.99 in.)

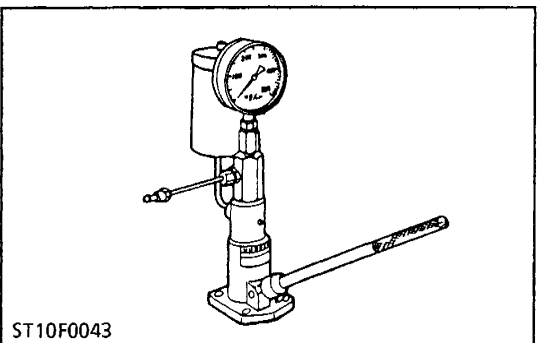
**Nozzle Tester**

Code No.: 07909-31361

Application: Use to check the fuel injection pressure and spraying condition of nozzle.

Measuring range: 0 to 49 MPa (0 to 500 kgf/cm², 0 to 7112 psi)

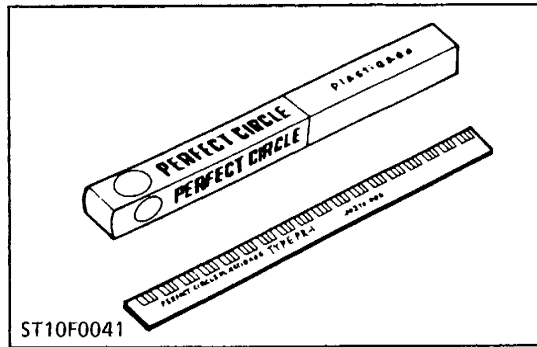

Press Gauge

Code No: 07909-30241

Application: Use to check the oil clearance between crankshaft and bearing, etc.

Measuring range: Green - 0.025 to 0.076 mm
 (0.001 to 0.003 in.)
 Red - 0.051 to 0.152 mm
 (0.002 to 0.006 in.)
 Blue - 0.102 to 0.229 mm
 (0.004 to 0.009 in.)

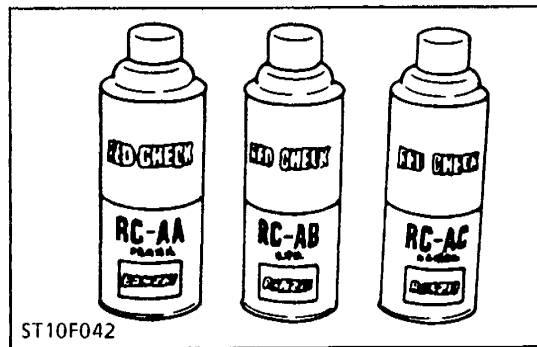

Red Check (Crack check liquid)

Code No.: 07909-31371

Application: Use to check cracks on cylinder head, cylinder block, etc.

NOTE

- Following special tools are not provided, so make them referring to the figures.

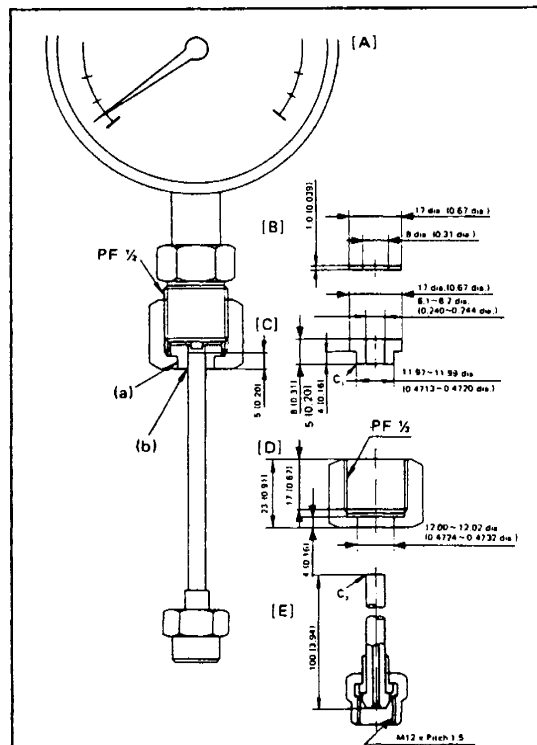

Injection Pump Pressure Tester

Application: Use to check fuel tightness of injection pumps.

A	Pressure gauge [Full scale : More than 40 MPa, 400 kgf/cm ² , 6000 psi]
B	Copper gasket
C	Flange
D	Hex. nut with across the flat 27 mm (1.06 in.)
E	Injection pipe
a	Adhesive application
b	Fillet welding on the enter circumference

ST10F046

Chamfer	mm	in.
C ₁	0.5	0.020
C ₂	0.5	0.020

** Unit : mm (in.)

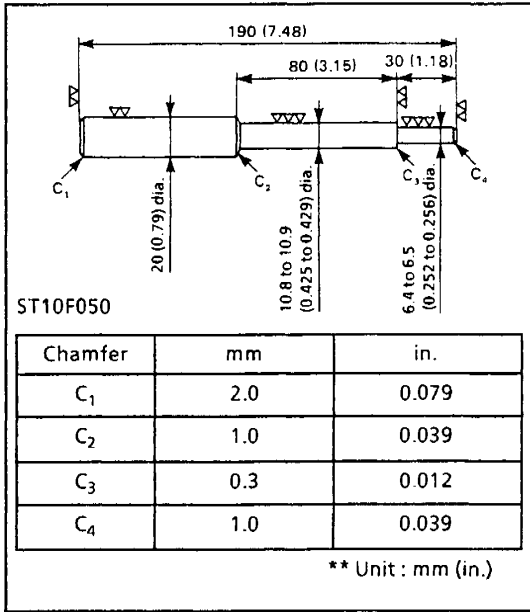

Valve Guide Replacing Tool

Application : Use to press out and to press fit the valve guide.

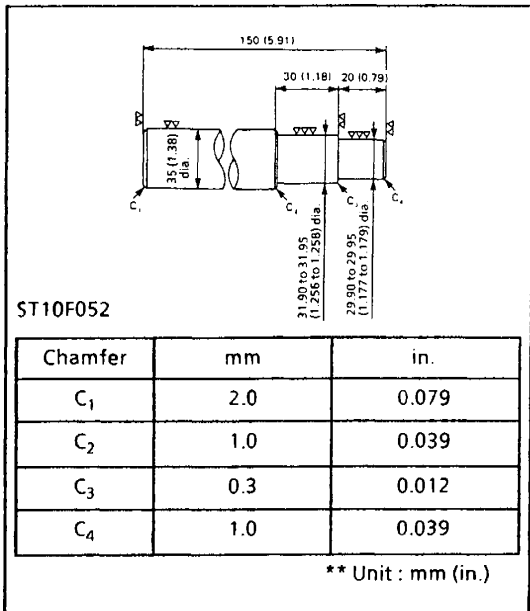

Idle Gear Bushing Replacing Tool

Application: Use to press out and to press fit the idle gear bushing.

ST10F053

Chamfer	mm	in.
C ₁	2.0	0.079
C ₂	1.0	0.039
C ₃	0.3	0.012
C ₄	1.0	0.039

** Unit : mm (in.)

Small End Bushing Replacing Tool

Application: Use to press out and to press fit the small end bushing.

ST10F053

*Chamfer	mm	in.
C ₁	2.0	0.079
C ₂	1.0	0.039
C ₃	0.3	0.012
C ₄	1.0	0.039

*Radius	mm	in.
R	140	1.57

** Unit : mm (in.)

Crankshaft Bearing 1 Replacing Tool

Application: Use to press out and to press fit the crankshaft bearing 1.

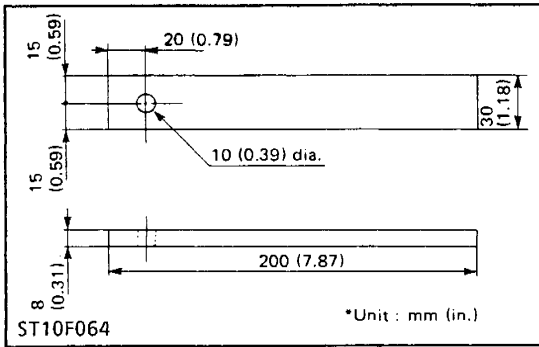

Flywheel Stopper

Application: Use to loosen and tighten the flywheel screw.

(2) Special Tools for Tractor

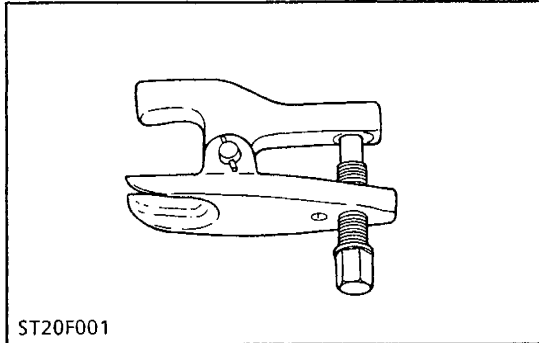

Tie Rod End Lifter

Code No.: 07909-39021

Application: This allows easy removal of tie rod end from tractor.

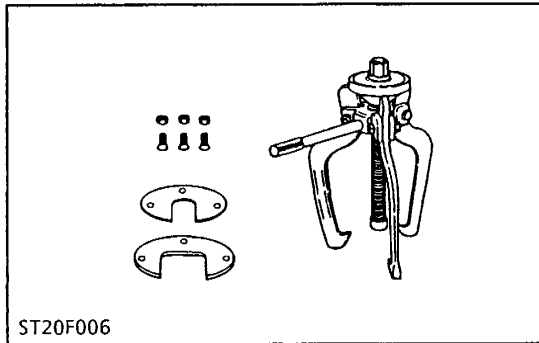

Steering Wheel Puller

Code No.: 07916-51090

Application: This allows easy removal of steering wheel without damaging steering shaft. For B and L series tractors, set the wheel support .

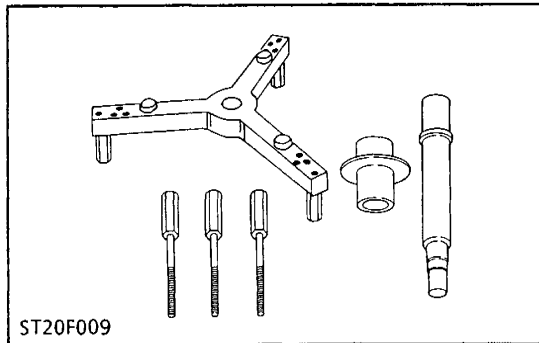

Dual Stage Clutch Exclusive Tool

Code No.: 07916-90052

Application: Use for mounting a dual stage clutch to the flywheel, and for checking and adjusting relative difference of the release lever or lever plate. (See page S.2-13)

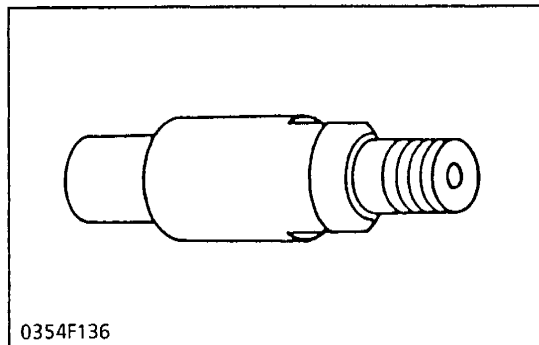

Clutch Centering Guide

Code No.: 07916-53471

After setting this centering guide to center bar, use center tool.

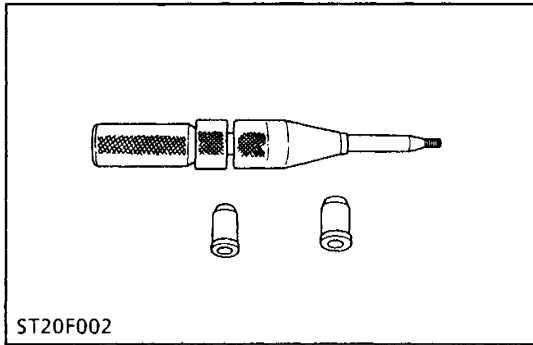

ST20F002

Clutch Center Tool (For B and L Series Tractors)

Code No.: 07916-51051

Application: The clutch center tool can be used for all B and L series tractors with a diaphragm clutch by changing tip guides.

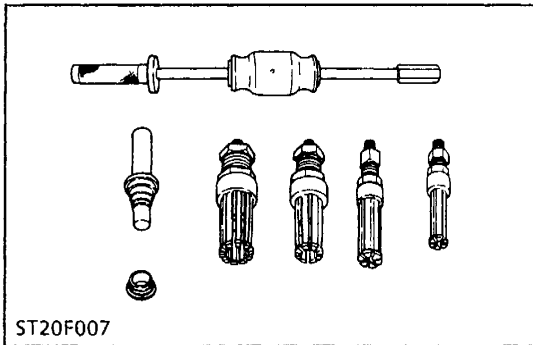

ST20F007

Knuckle Spindle Bushing Replacement Tool

Code No.: 07916-51030

Application: This allows easy press fitting and removal of knuckle spindle bushing for front axle without use of press.

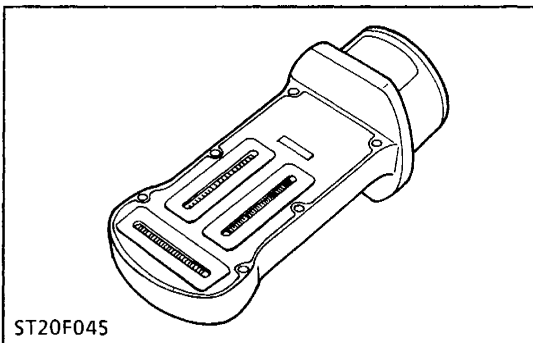

ST20F045

Camber, Caster and Kingpin Gauge

Code No.: 07909-31691

Application: This allows easy measurement of camber angle, caster angle and kingpin inclination for all tractor models.

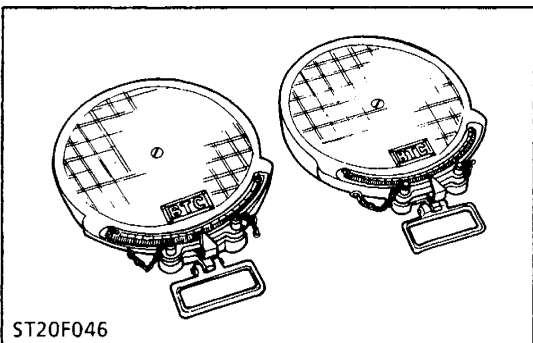

ST20F046

Turning Radius Gauge

Code No.: 07909-31701

Application: This allows easy measurement of steering angle for all tractor models.

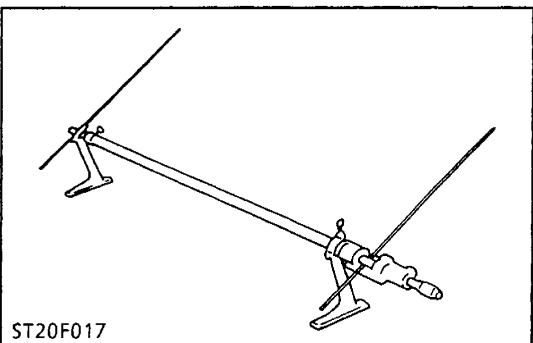

ST20F017

Toe-in Gauge

Code No.: 07909-31681

Application: This allows easy measurement of toe-in for all tractor models.

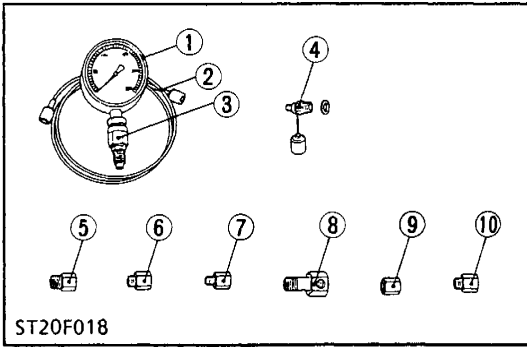

Relief Valve Set Pressure Tester

Code No.: 07916-50045

Application: This allows easy measurement of relief set pressure for all tractor models.

- | | |
|---|---------------------------------------|
| (1) Gauge (07916-50321) | (6) Adaptor C (PS3/8) (07916-50371) |
| (2) Cable (07916-50331) | (7) Adaptor D (PT1/8) (07916-50381) |
| (3) Threaded Joint (07916-50401) | (8) Adaptor E (PS3/8) (07916-50392) |
| (4) Threaded Joint (07916-50341) | (9) Adaptor F (PF1/2) (07916-52601) |
| (5) Adaptor B (M18X P1.5) (07916-50361) | (10) Adaptor 58 (PT1/4) (07916-52931) |

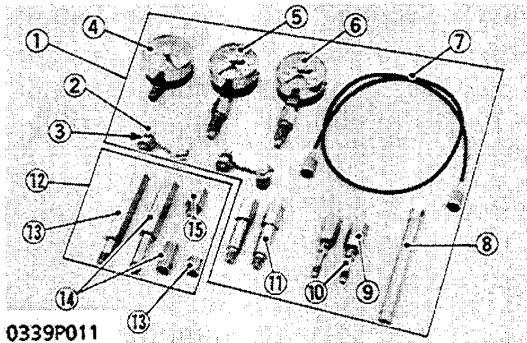

Hydrostatic Transmission Tester and HST Adaptor Set

Hydrostatic Transmission Tester: 07916-52040

Application: This allows easy measurement of hydrostatic transmission pressure.

HST Adaptor Set : 07916-53072

Application: This allows easy measurement of hydrostatic transmission pressure.

- | | | | |
|---|--|-------------------------------------|--|
| (1) Hydrostatic Transmission Tester (07916-52040) | (6) Pressure Gauge (High pressure) (in Relief Valve Set Pressure Tester) (07916-50321) | (8) Valve Seat Driver (07916-60841) | (13) Adaptor 2 with Collar (07916-52632) |
| (2) Connector 3 (07916-50341) | (7) HN Tube (in Relief Valve Set Pressure Tester) (07916-50331) | (9) Connector 1 (07916-60811) | (14) Adaptor 3 with Collar (07916-52642) |
| (3) Gasket (04714-00200) | | (10) Connector 2 (07916-60821) | (15) Adaptor 1 (07916-52621) |
| (4) Vacuum Gauge (07916-51331) | | (11) Long Connector (07916-60831) | |
| (5) Pressure Gauge (Low pressure) (07916-51301) | | (12) HST Adaptor Set (07916-53072) | |

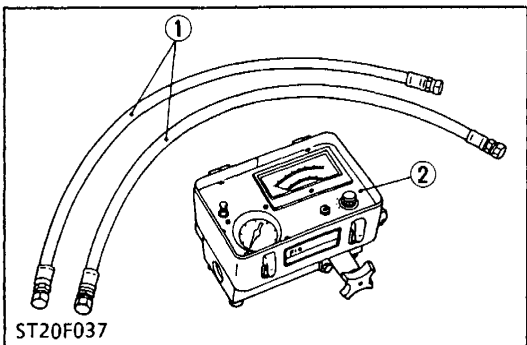

Flowmeter

Flowmeter

Code No. : 07916-52791

Hydraulic Test Hose Code No. : 07916-52651 (1 pc.)

Application: This allows easy testing of hydraulic system.

- | | |
|--------------------------|----------------|
| (1) Hydraulic Test Hoses | (2) Flow Meter |
|--------------------------|----------------|

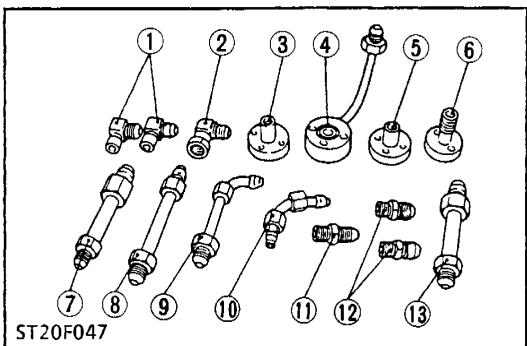

Adaptor Set

Code No.: 07916-54031

Application: Use for checking hydraulic pumps.

- | | |
|----------------|--------------------------|
| (1) Adaptor 52 | (8) Adaptor 65 |
| (2) Adaptor 53 | (9) Adaptor 66 |
| (3) Adaptor 54 | (10) Adaptor 67 |
| (4) Adaptor 61 | (11) Adaptor 68 |
| (5) Adaptor 62 | (12) Adaptor 69 |
| (6) Adaptor 63 | (13) Hydraulic Adaptor 1 |
| (7) Adaptor 64 | |

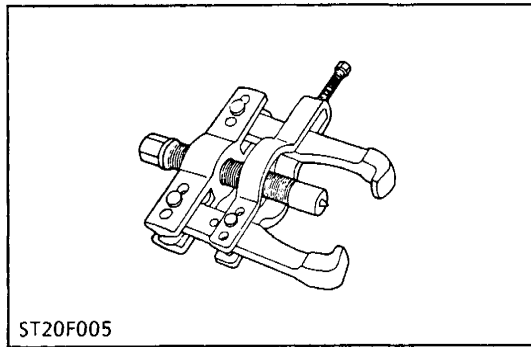

Pitman Arm Puller

Code No.: 07909-39011

Application: Use for pulling out pitman arm from tractor.

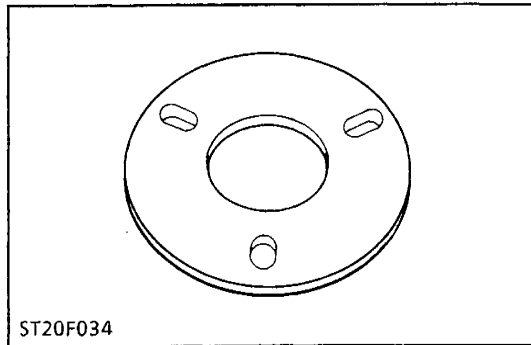

Power Steering Valve Holder

Code No.: 07916-52891

Application: Use for disassembling and assembling the power steering valve.

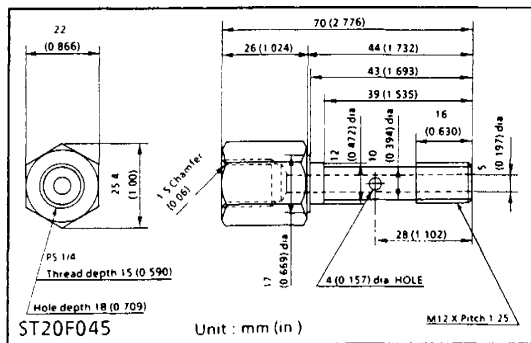

Power Steering Relief Pressure Adaptor

Application: Use for checking power steering relief pressure.

CONTENTS

TIGHTENING TORQUES	S.S-1
[B1550-B1750-B1550HST-B1750HST]	S.S-1
[B2150-B2150HST]	S.S-2
ADJUSTING	S.S-3
DISASSEMBLING AND ASSEMBLING	S.S-4
[B1550-B1750-B1550HST-B1750HST]	
[1] DRAINING COOLING WATER AND OIL	S.S-4
[2] SEPARATING FRONT AXLE FROM ENGINE	S.S-6
[3] SEPARATING ENGINE FROM CLUTCH HOUSING	S.S-7
[B1550-B1750]	
[4] SEPARATING CLUTCH HOUSING FROM TRANSMISSION	S.S-9
[5] SEPARATING HYDRAULIC CYLINDER FROM DIFFERENTIAL	S.S-10
[6] SEPARATING TRANSMISSION CASE FROM DIFFERENTIAL GEAR CASE	S.S-11
[7] SEPARATING AXLE CASE	S.S-12
[B1550HST-B1750HST]	
[8] SEPARATING CLUTCH HOUSING FROM TRANSMISSION	S.S-12
[9] SEPARATING HYDROSTATIC TRANSMISSION	S.S-14
[10] SEPARATING HYDRAULIC CYLINDER FROM DIFFERENTIAL	S.S-14
[11] SEPARATING TRANSMISSION CASE FROM DIFFERENTIAL GEAR CASE	S.S-15
[12] SEPARATING AXLE CASE FROM DIFFERENTIAL	S.S-15
[B2150-B2150HST]	
[1] DRAINING COOLING WATER AND OIL	S.S-16
[2] SEPARATING FRONT AXLE FROM ENGINE	S.S-17
[3] SEPARATING ENGINE FROM CLUTCH HOUSING	S.S-19
[B2150]	
[4] SEPARATING CLUTCH HOUSING FROM TRANSMISSION	S.S-21
[5] SEPARATING TRANSMISSION CASE FROM DIFFERENTIAL GEAR CASE	S.S-22
[6] SEPARATING AXLE CASE AND HYDRAULIC CYLINDER FROM DIFFERENTIAL	S.S-24
[B2150HST]	
[7] SEPARATING CLUTCH HOUSING FROM TRANSMISSION	S.S-26
[8] SEPARATING TRANSMISSION CASE FROM DIFFERENTIAL GEAR CASE	S.S-29
[9] SEPARATING AXLE CASE AND HYDRAULIC CYLINDER FROM DIFFERENTIAL	S.S-32

TIGHTENING TORQUES

Tightening torques of screws and nuts on the table below are especially specified.
(For general use screws and nuts: See page S.G-4)

[B1550-B1750-B1550HST-B1750HST]

Section	Item	N·m	kgf·m	ft-lbs
Front Axle	Drag link slotted nut	17.7 to 34.3	1.8 to 3.5	13.0 to 25.3
	Front axle frame mounting screw to engine	39.2 to 64.7	4.0 to 6.6	28.9 to 47.7
Engine	Engine mounting screw	23.5 to 27.5	2.4 to 2.8	17.4 to 20.3
Clutch Housing	Clutch housing mounting nut	41.2 to 58.8	4.2 to 6.0	30.4 to 43.4
Rear Axle	Rear wheel mounting screw and nut	166.7 to 191.2	17.0 to 19.5	123.0 to 141.0
	Rear axle case mounting screw M10	39.2 to 64.7	4.0 to 6.6	28.9 to 47.7
	M12	60.8 to 106.9	6.2 to 10.9	44.8 to 78.8
Control Valve	Control valve mounting screw	16.7 to 21.6	1.7 to 2.2	12.3 to 15.9
3-point Hitch	Top link bracket mounting screw	39.2 to 64.7	4.0 to 6.6	28.9 to 47.7
	Hitch mounting screw	77.5 to 90.2	7.9 to 9.2	57.1 to 66.5
Steering	Steering wheel mounting nut	41.2 to 58.8	4.2 to 6.0	30.4 to 43.4
	Steering gear box mounting nut	39.2 to 64.7	4.0 to 6.6	28.9 to 47.7
	Steering assembly mounting nut	48.1 to 55.9	4.9 to 5.7	35.4 to 41.2
Mid PTO	Drive case mounting screw	48.1 to 55.9	4.9 to 5.7	35.4 to 41.2
	Cover mounting screw	13.7 to 19.6	1.4 to 2.0	10.1 to 14.5
Hydraulic Cylinder	Hydraulic cylinder mounting screw	20.6 to 29.4	2.1 to 3.0	15.2 to 21.7
Hydraulic Block Type Outlet	Joint bolt	53.9 to 68.6	5.5 to 7.0	39.8 to 50.6
Transmission Case	Transmission case mounting nut	39.2 to 64.7	4.0 to 6.6	28.9 to 47.7
HST	HST mounting screw	48.1 to 55.9	4.9 to 5.7	35.4 to 41.2

TIGHTENING TORQUES (CONTINUED)**[B2150-B2150HST]**

Section	Item	N·m	kgf·m	ft·lbs
Front Axle	Drag link slotted nut	48.1 to 55.9	4.9 to 5.7	35.4 to 41.2
	Front axle frame mounting screw to engine	48.1 to 55.9	4.9 to 5.7	35.4 to 41.2
Engine	Engine mounting screw and nut to clutch housing	M8 48.1 to 55.9	2.4 to 2.8 4.9 to 5.7	17.4 to 20.2 35.4 to 41.2
		M10		
Clutch Housing	Clutch housing mounting screw and nut to transmission case	77.5 to 90.2	7.9 to 9.2	57.1 to 66.5
Rear Axle	Rear wheel mounting screw and nut	196 to 294	20 to 30	145 to 166
	Rear axle case mounting screw	M10 34.3 to 39.2	3.5 to 4.0	25.3 to 28.9
		M12 73.5 to 78.5	7.5 to 8.0	54.2 to 57.9
HST	HST mounting screw	48.1 to 55.9	4.9 to 5.7	35.4 to 41.2
Control Valve	Control valve mounting screw	23.5 to 27.5	2.4 to 2.8	17.4 to 20.2
3-point Hitch	Top link bracket mounting screw	48.1 to 55.9	4.9 to 5.7	35.4 to 41.2
	Side plate mounting screw	73.5 to 78.5	7.5 to 8.0	54.2 to 57.9
		77.5 to 90.2	7.9 to 9.2	57.1 to 66.5
	Hitch mounting screw	73.5 to 78.5	7.5 to 8.0	54.2 to 57.9
Steering	Steering wheel mounting nut	29.4 to 49.0	3.0 to 5.0	21.7 to 36.1
	Steering assembly mounting nut	48.1 to 55.9	4.9 to 5.7	35.4 to 41.2
Mid PTO	Drive case mounting screw	48.1 to 55.9	4.9 to 5.7	35.4 to 41.2
	Cover mounting screw	13.7 to 19.6	1.4 to 2.0	10.1 to 14.5
Hydraulic Cylinder	Hydraulic cylinder mounting screw and nut	34.3 to 39.2	3.5 to 4.0	25.3 to 28.9
Hydraulic Block Type Outlet	Hydraulic block type outlet mounting screw	17.7 to 20.6	1.8 to 2.1	13.0 to 15.2
Transmission Case	Transmission case mounting screw and nut	34.3 to 39.2	3.5 to 4.0	25.3 to 28.9

ADJUSTING

Refer to the adjustment in S.1 to S.9 section when reassembling.
Specially the adjustment of mechanical linkage is as follows.

- Fuel line bleeding Refer to S.G-20, 21.
- Engine fuel cut off linkage Refer to S.9-19.
- Clutch pedal linkage Refer to S.2-4,5,9,10.
- Brake pedal linkage Refer to S.5-2
- 3 point hitch feed-back rod linkage Refer to S.8-12.
- Bi-speed turn linkage Refer to S.6-12,13.
- HST pedal control Refer to S.3-10,48,49.

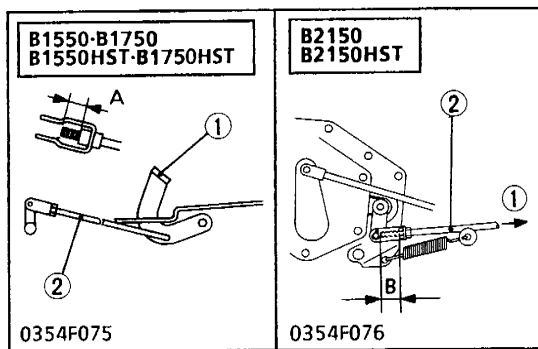

- Differential lock pedal linkage
[B1550-B1750-B1550HST-B1750HST]
 Connect the differential lock pedal rod to its pedal so that its length "A" is equal to 13 to 17 mm (0.51 to 0.66 in.).
[B2150-B2150HST]
 Connect the differential lock pedal rod to its pedal so that its length "B" is equal to 13 to 17 mm (0.51 to 0.66 in.).

- (1) Differential Lock Pedal (2) Differential Lock Rod

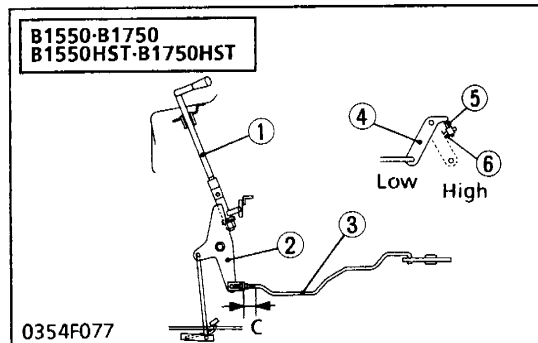

- Accelerator control rod linkage
[B1550-B1750-B1550HST-B1750HST]
 1. Adjust the accelerator control rod length "C" so that the speed adjustment lever touches each setting bolt when the accelerate lever position is the lowest and highest.

Reference length "C"	15 to 20 mm (0.59 to 0.78 in.)
Engine idling speed	920 to 1100 rpm

[B2150-B2150HST]

Engine idling speed	950 to 1050 rpm
---------------------	-----------------

■ NOTE

- High engine speed is not necessary to adjust.

- (1) Accelerating Lever (4) Speed Control Lever
- (2) Release Arm (5) Adjusting Bolt (Low Speed)
- (3) Accelerator Control Rod (6) Adjusting Bolt (High Speed)

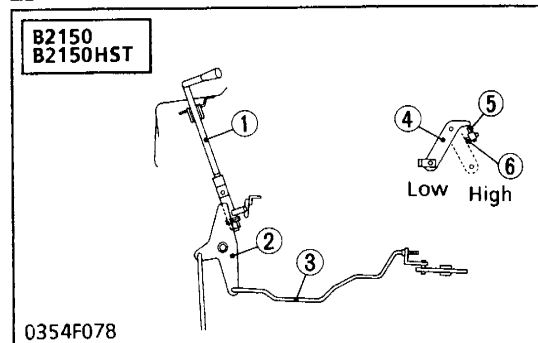

DISASSEMBLING AND ASSEMBLING

[B1550-B1750-B1550HST-B1750HST]

[1] DRAINING COOLING WATER AND OIL

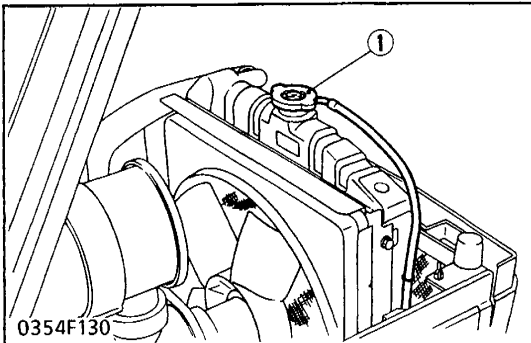

Draining Cooling Water

⚠ CAUTION

- Never open the radiator cap while operating or immediately after stopping. Otherwise, hot water will spout out from the radiator. Wait for more than ten minutes to cool the radiator, before opening the cap.

1. Remove the drain plug (2) from the radiator to drain cooling water.

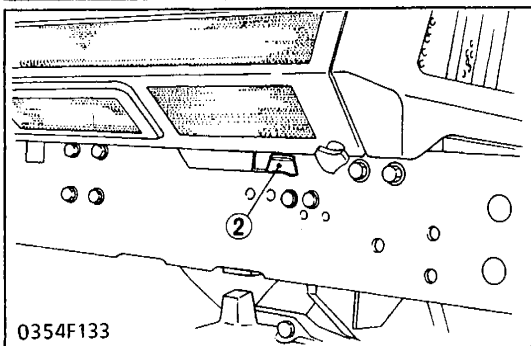

Capacity	Coolant	B1550 B1550HST	2.9 ℓ 3.1 U.S. qts. 2.55 Imp. qts.
		B1750 B1750HST	3.5 ℓ 3.7 U.S. qts. 3.08 Imp. qts.

■ NOTE

- Remove the radiator cap (1) to drain cooling water completely.

(1) Radiator Cap

(2) Drain Plug

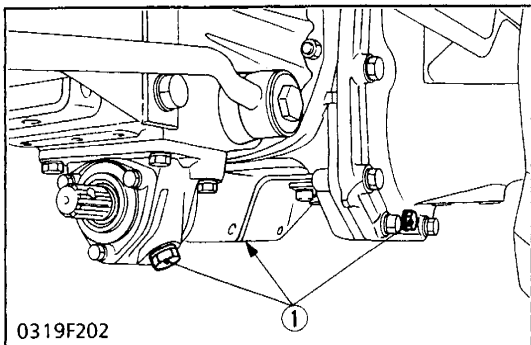

Draining Transmission Oil

1. Remove the drain plug (1) to drain transmission oil.

Place	Model	Capacity	Lubricants	
			Maker	Brand (Standard)
Transmission	B1550 B1750	12 ℓ 12.7 U.S.qts 10.6 Imp.qts	● KUBOTA ● Others	UDT hydrostatic transmission fluid Refer to the table of "LUBRICANTS AND FLUID" in S.G-3.
	B1550HST B1750HST	13.5 ℓ 14.3 U.S.qts 11.88 Imp.qts		

(1) Drain Plug

(3) Oil Port

(2) Dipstick

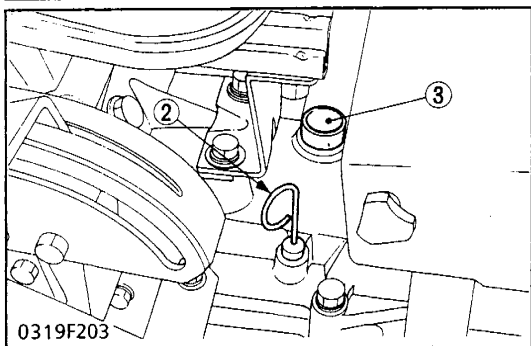

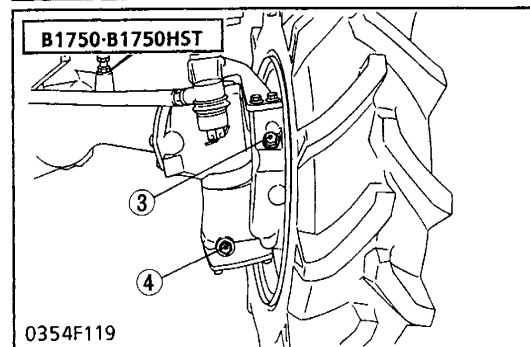
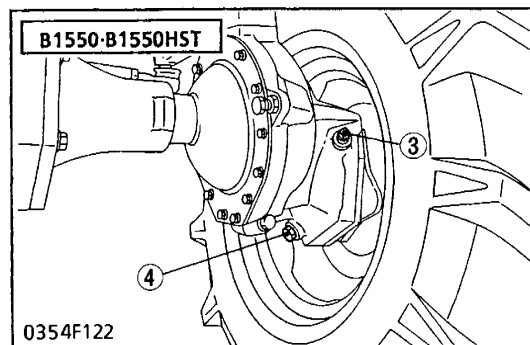
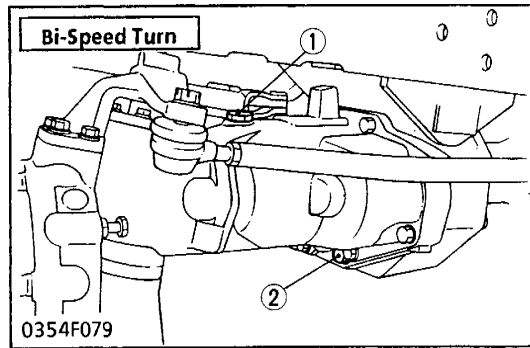
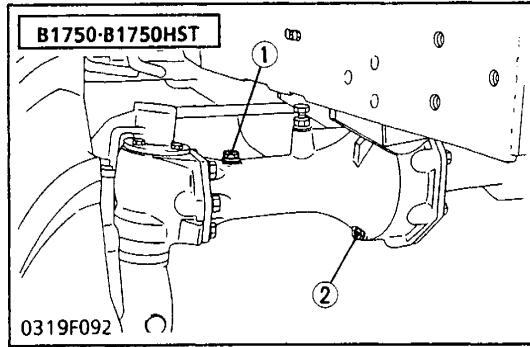
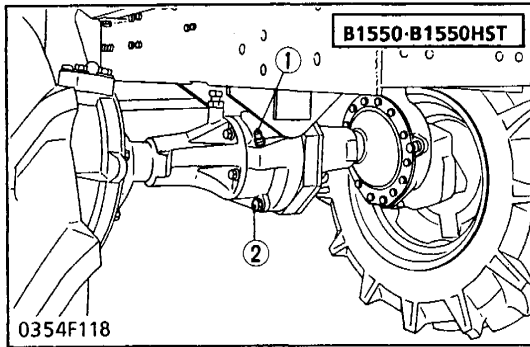

Draining Front Axle Differential Case Oil (4WD)

1. Remove the drain plug (2) from the front axle differential case to drain oil.

Place	Model	Capacity	Lubricants
Front axle diff. case (Front axle case)	B1550 B1550HST	0.5 ℓ 0.5 U.S. qts. 0.44 Imp. qts.	Gear oil SAE 80 or SAE 90
Front axle gear case (Front axle arm)	B1750 B1750HST	1.5 ℓ 1.6 U.S. qts. 1.32 Imp. qts.	
Front axle differential case	Bi-speed Turn	2.5 ℓ 2.6 U.S. qts. 2.20 Imp. qts.	

NOTE

● Remove the filling port plug (1) to drain oil completely.

(1) Filling Port Plug

(2) Drain Plug

Draining Front Axle Gear Case Oil (4WD)

1. Remove the drain plug (4) from the front axle gear case to drain oil.

Place	Model	Capacity	Lubricants
Front axle gear case (Gear case)	B1550 B1550HST	0.15 ℓ x 2 0.16 U.S. qts. x 2 0.13 Imp. qts. x 2	Gear oil SAE 80 or SAE 90
Front axle gear case (Front axle case)	B1750 B1750HST	0.5 ℓ x 2 0.5 U.S. qts. x 2 0.44 Imp. qts. x 2	

NOTE

● Remove the filling port plug (3) to drain oil completely.

(3) Filling Port Plug

(4) Drain Plug

[2] SEPARATING FRONT AXLE FROM ENGINE

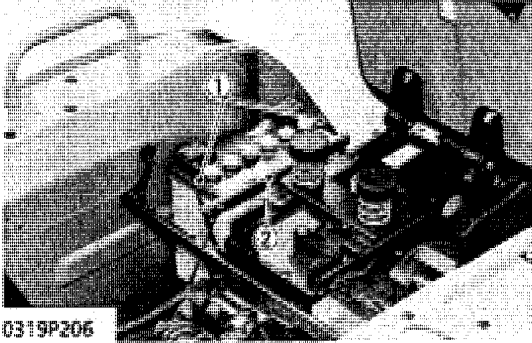

Battery

1. Remove the battery cords (1).
2. Remove the battery retainer (2), and remove the battery.

NOTE

- When disconnecting the battery cords, disconnect the grounding cord first. When connecting, connect the positive cord first.

(1) Battery Cord

(2) Battery Retainer

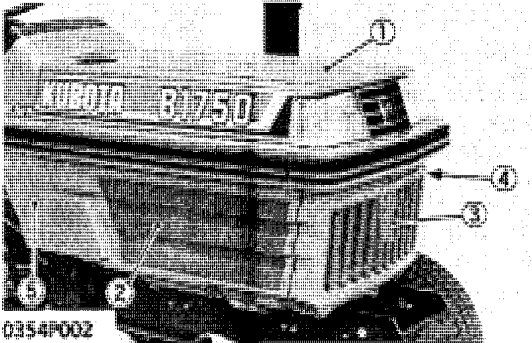

Hood and Skirts

1. Open the hood from the front and remove the B-shape pins and hood link for keeping it open. And remove the hood (1).
2. Remove the right and left skirts (2), (4) with the auxiliary skirt (LH). After removing screws and sliding a little skirts forward, remove them.
3. Remove the front skirt (3) by removing screws.
4. Remove both sides of dust cover (5) by removing screws.

(1) Hood

(4) Left Skirt

(2) Right Skirt

(5) Dust Cover

(3) Front Skirt

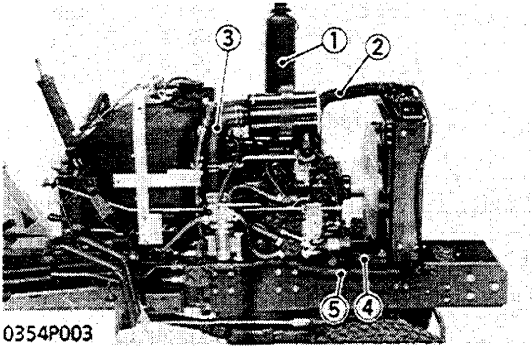

Water Pipes, Inlet Pipe, Suction Pipe 2 and Muffler

1. Loosen the clamps and disconnect water pipe 1 (4), water pipe 4 (2) and the drain pipe (5).
2. Loosen the clamps and disconnect suction pipe 2 from oil cooler and remove the pipe mounting screw. (HST TYPE)
3. Remove the muffler (1).

(1) Muffler

(4) Water Pipe 1

(2) Water Pipe 4

(5) Drain Pipe

(3) Inlet Pipe

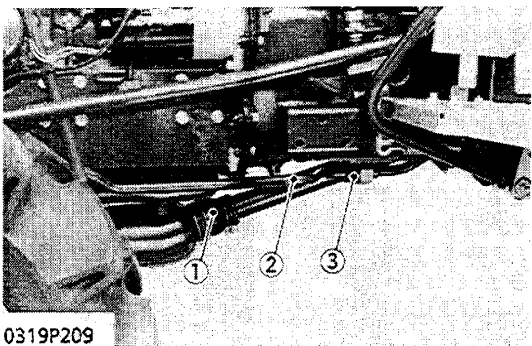

Pipe 3 (4WD) and Return Pipe 2

1. Loosen the clamps and slide pipe 3 (1) backward.
2. Disconnect the return pipe 2 (2) at the joint (3). (HST TYPE)

(1) Pipe 3

(3) Joint

(2) Return Pipe 2

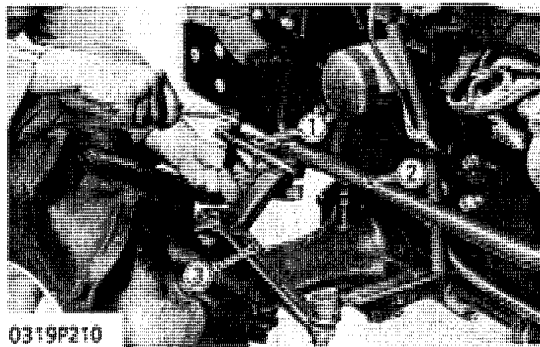

Drag Link

1. Steer the front wheels to the left.
2. Remove the slotted nut connecting the knuckle arm (3) and drag link (2), and disconnect the drag link at the front end with a tie rod end lifter (1) (Code No: 07909-39021).
3. Remove the bi-speed turn linkage from its gear box. (Bi-speed Turn)

■ IMPORTANT

- After tightening the slotted nut to the specified torque, install the cotter pin as shown in the figure.

Tightening torque	Slotted nut	17.7 to 34.3 N·m 1.8 to 3.5 kgf·m 13.0 to 25.3 ft-lbs
-------------------	-------------	---

- (1) Tie Rod End Lifter (3) Knuckle Arm
(2) Drag Link

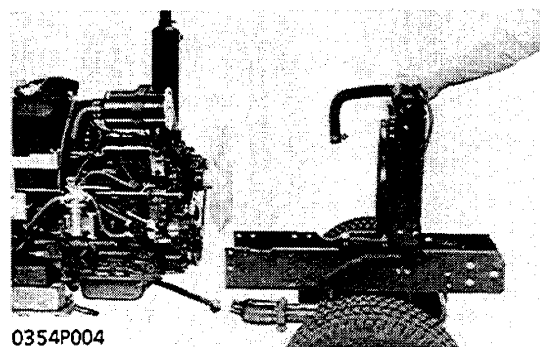

Separating Front Axle Assembly

1. Remove the front axle frame mounting screws and separate the front axle assembly from the engine.

(When reassembling)

- Correctly align the drive shaft and universal joint spline (4WD type only).

Tightening torque	Front axle frame mounting screw	39.2 to 64.7 N·m 4.0 to 6.6 kgf·m 28.9 to 47.7 ft-lbs
-------------------	---------------------------------	---

[3] SEPARATING ENGINE FROM CLUTCH HOUSING

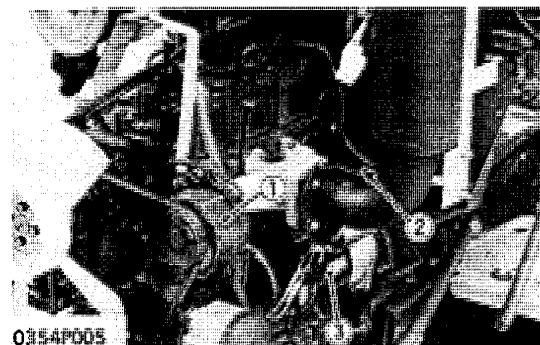

Starter and Wiring

1. Disconnect the wiring from the dynamo (1).
2. Disconnect the wiring from the oil switch (2).
3. Disconnect the wiring from the starter (3), and remove the starter from the engine.

- (1) Dynamo (3) Starter
(2) Oil Switch

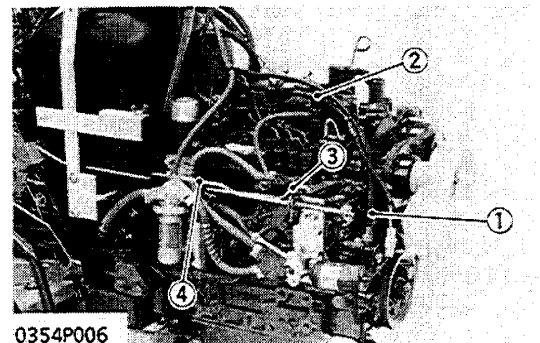

Rod, Wires, Cable and Wiring

1. Remove the accelerator control rod (3) from the speed change lever.
2. Disconnect the engine stop rod (4) from the stop lever.
3. Disconnect the hourmeter cable (1).
4. Disconnect the wiring (2) for the glow plug.
5. Disconnect the wiring (2) from the engine kill off solenoid valve and from the coolant temperature gauge.

- (1) Hourmeter Cable (3) Accelerator Control Rod
(2) Wiring (4) Engine Stop Rod

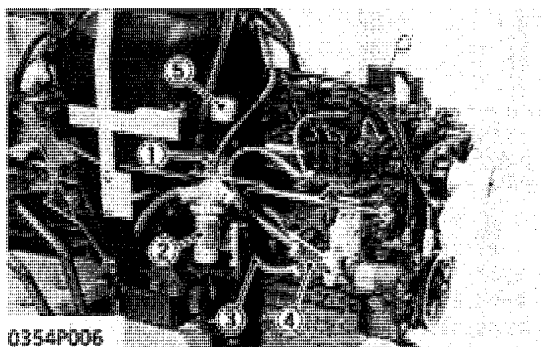

Fuel Pipe

1. Close the filter cock.
2. Disconnect the fuel pipe (3) between the fuel pump (4) and the fuel filter (2) at the fuel filter side.
3. Take off the air cleaner holder from its cleaner.
4. Remove the filter mounting screws (1), and remove the fuel filter from the engine.

- (1) Screw (4) Fuel Pump
 (2) Fuel Filter (5) Inlet Pipe
 (3) Fuel Pipe

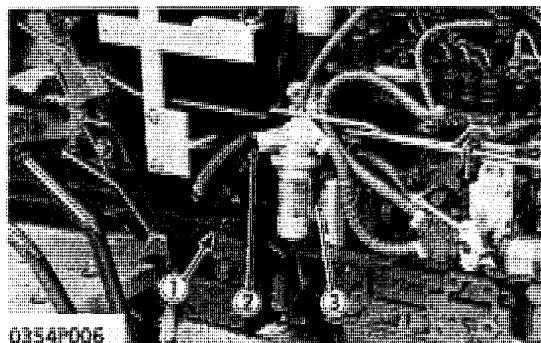

Suction Pipe 1, Delivery Pipe and Shutter Plate

1. Disconnect the suction pipe 1 (2) from the hydraulic pump (3).
2. Remove the delivery pipe joint nut (1).
3. Disconnect the delivery pipe joint nut for power steering from the hydraulic block type outlet.

- (1) Delivery Pipe Joint Nut (3) Hydraulic Pump
 (2) Suction Pipe 1

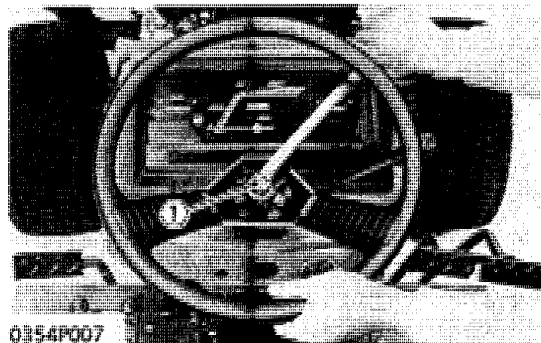

Steering Wheel

1. Remove the steering wheel cap.
2. Remove the steering wheel mounting nut (1), and remove the wheel with a steering wheel puller (Code No: 07916-51090).

Tightening torque	Steering wheel mounting nut	41.2 to 58.8 N·m 4.2 to 6.0 kgf·m 30.4 to 43.4 ft·lbs
-------------------	-----------------------------	---

- (1) Steering Wheel Mounting Nut

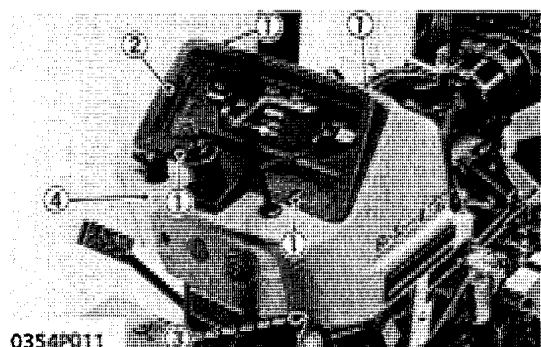

Meter Panel

1. Remove the panel board screws (1) and disconnect the couplers and hour-meter cable from the body. And remove the panel board (2).
2. Disconnect the wiring harness from the timer relay, regulator, main switch, hazard switch and hazard unit.
3. Remove the meter panel mounting screws (3), and remove the meter panel (4).

- (1) Panel Board Screws (3) Meter Panel Screws
 (2) Panel Board (4) Meter Panel

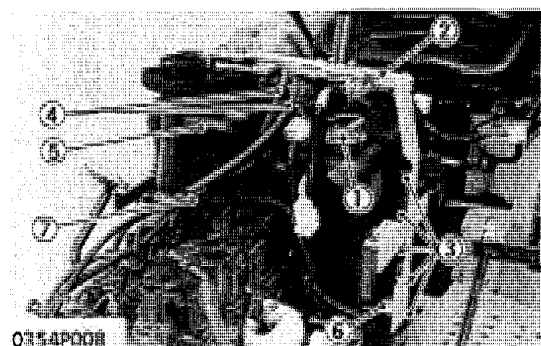

Fuel Tank

1. Disconnect the wiring for the fuel unit (1) and wiring band (7).
2. Remove the fuel tank support mounting screws (3), and remove the fuel tank (5).
3. Remove the fuel tank frame support (6) and dust covers.

- (1) Fuel Unit (5) Fuel Tank
 (2) Fuel Tank Support (6) Fuel Tank Frame Support
 (3) Screws (7) Wiring Band
 (4) Fuel Pipes

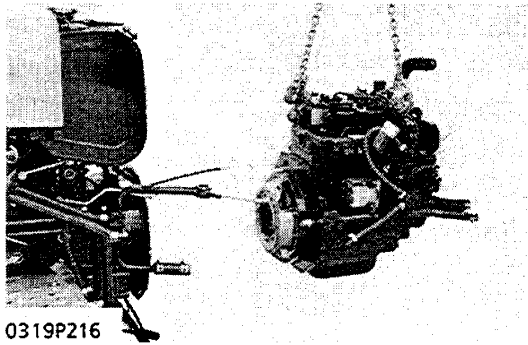

0319P216

Separating Engine

1. Remove the mounting screws, and separate the engine from the clutch housing.

(When reassembling)

- Be sure to replace the gasket on the clutch housing with a new one.

Tightening torque	Engine mounting screw	23.5 to 27.5 N·m 2.4 to 2.8 kgf·m 17.4 to 20.2 ft-lbs
-------------------	-----------------------	---

Go to the Section [8] in S.S-12 for B1550HST-B1750HST.

[B1550-B1750]

**[4] SEPARATING CLUTCH HOUSING FROM TRANSMISSION
[GEAR TRANSMISSION TYPE]**

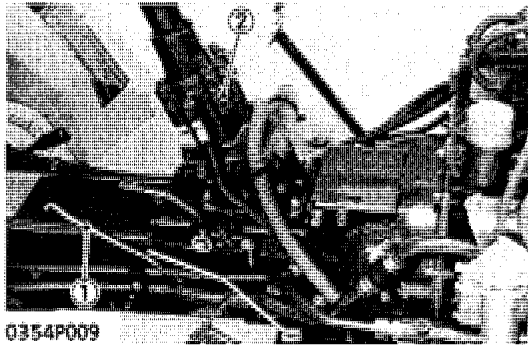

0354P009

Steering Assembly

1. Remove the accelerator control rods (1), for the foot accelerator control and speed change lever.
2. Remove the bonnet rear support in front of the steering assembly.
3. Disconnect the delivery pipe and return pipe for power steering from its valve. (If powers steering equipped)
4. Remove the steering assembly (2) from the clutch housing.

Tightening torque	Steering gear box mounting nut	39.2 to 64.7 N m 4.0 to 6.6 kgf·m 28.9 to 47.7 ft-lbs
	Slotted nut	17.7 to 34.3 N m 1.8 to 3.5 kgf·m 13.0 to 25.3 ft-lbs

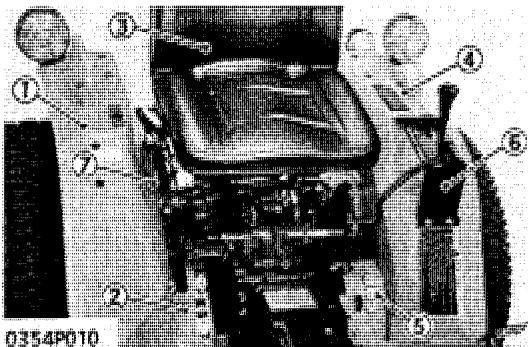

0354P010

Seat, Tires, Fenders and Covers

1. Remove the seat (3) and wiring from the tail and hazard lights.
2. Remove the left and right tires.
3. Remove the left and right covers (5), (2) and main shift guide (6).
4. Remove the right fender (1) with the lever guide (7).
5. Remove the left fender (4) with fender stay and battery bracket.

Tightening torque	Rear wheel hub cotter 2 and nut	166.7 to 191.2 N·m 17.0 to 19.5 kgf·m 123.0 to 141.0 ft lbs
-------------------	---------------------------------	---

- (1) Fender (RH)
- (2) Cover (RH)
- (3) Seat
- (4) Fender (LH)
- (5) Cover (LH)
- (6) Main Shift Guide
- (7) Position Control Lever Guide

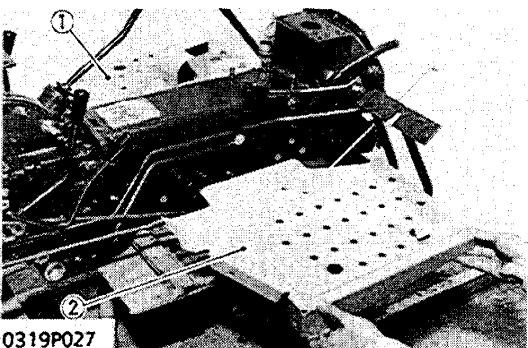

0319P027

Steps

1. Remove the cotter pins from both sides of step bracket under the steps.
2. Remove the left and right steps (1), (2).

- (1) Step (LH)
- (2) Step (RH)

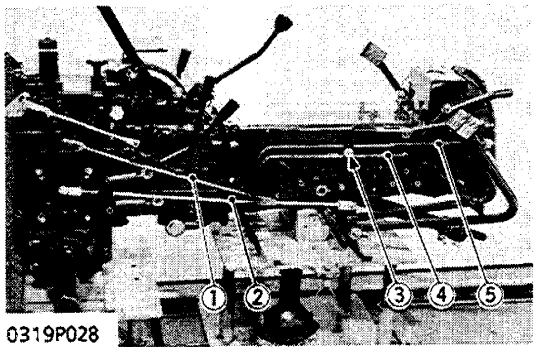

0319P028

Inlet Pipe, Delivery Pipe and Rods

1. Remove the pipe clamp (3), and remove the inlet pipe (4) and delivery pipe (5).
2. Remove the left and right brake rods (2)..
3. Remove the differential lock rod (1).

(When reassembling)

- Use care not to damage the O-rings on the inlet pipe.

- | | |
|---------------------------|-------------------|
| (1) Differential Lock Rod | (4) Inlet Pipe |
| (2) Brake Rod | (5) Delivery Pipe |
| (3) Pipe Clamp | |

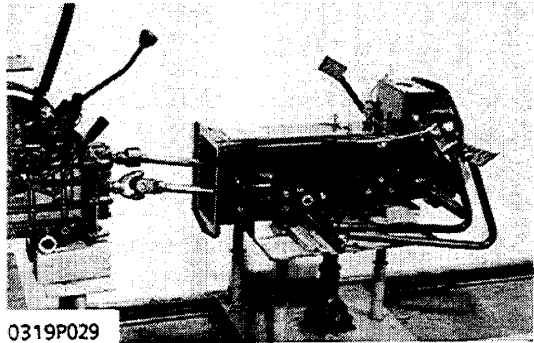

0319P029

Separating Clutch Housing

1. Remove the clutch housing mounting nuts, and separate the clutch housing.

Tightening torque	Clutch housing mounting nut	41.2 to 58.8 N·m 4.2 to 6.0 kgf·m 30.4 to 43.4 ft·lbs
-------------------	-----------------------------	---

[5] SEPARATING HYDRAULIC CYLINDER FROM DIFFERENTIAL [GEAR TRANSMISSION TYPE]

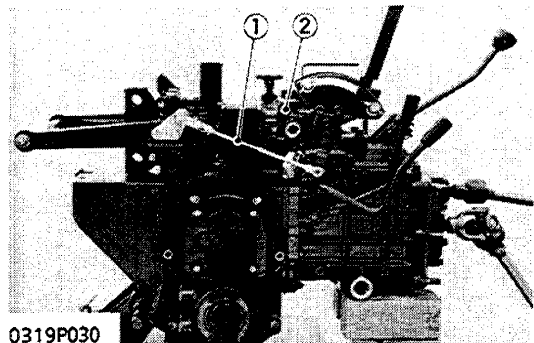

0319P030

Control Valve

1. Remove the control valve (2) with the feedback rod (1). (4WD type)

(When reassembling)

- Use care not to damage the O-rings on the control valve.

Tightening torque	Control valve mounting screw	16.7 to 21.6 N·m 1.7 to 2.2 kgf·m 12.3 to 15.9 ft·lbs
-------------------	------------------------------	---

- | | |
|------------------|-------------------|
| (1) Feedback Rod | (2) Control Valve |
|------------------|-------------------|

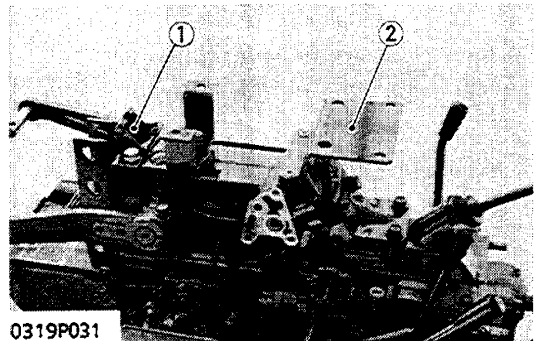

0319P031

Cylinder Cap Stay and Top Link Bracket

1. Remove the cylinder cap stay (2).
2. Remove the top link bracket (1).

Tightening torque	Cylinder cap stay mounting screw	M10	20.6 to 29.4 N·m 2.1 to 3.0 kgf·m 15.2 to 21.7 ft·lbs
		M12	60.8 to 106.9 N·m 6.2 to 10.9 kgf·m 44.8 to 78.8 ft·lbs

Tightening torque	Top link bracket mounting screw	39.2 to 64.7 N·m 4.0 to 6.6 kgf·m 28.9 to 47.7 ft·lbs
-------------------	---------------------------------	---

- | | |
|----------------------|-----------------------|
| (1) Top Link Bracket | (2) Cylinder Cap Stay |
|----------------------|-----------------------|

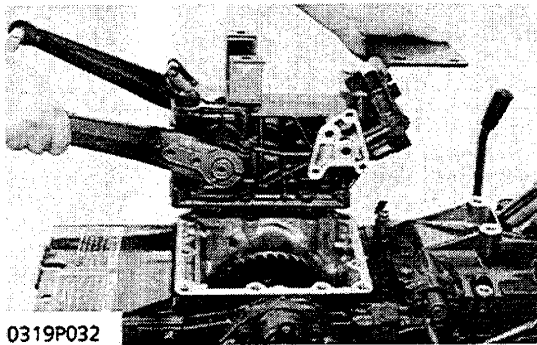

0319P032

Hydraulic Cylinder

1. Remove the hydraulic cylinder mounting screws, and separate the hydraulic cylinder.

(When reassembling)

- Be sure to replace the gasket with a new one.

Tightening torque	Hydraulic cylinder mounting screw	20.6 to 29.4 N·m 2.1 to 3.0 kgf·m 15.2 to 21.7 ft·lbs
-------------------	-----------------------------------	---

**[6] SEPARATING TRANSMISSION CASE FROM DIFFERENTIAL GEAR CASE
[GEAR TRANSMISSION TYPE]**

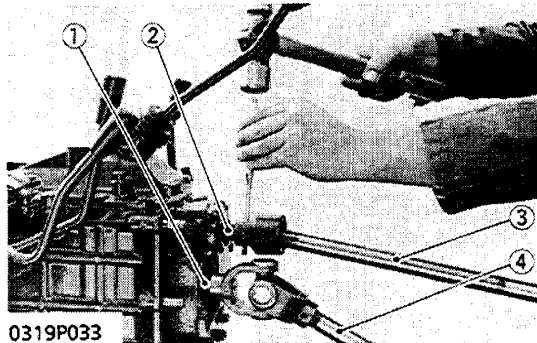

0319P033

Propeller Shaft and Drive Shaft

1. Remove the propeller shaft (3) from the 1st shaft (2).
2. Remove the drive shaft (4) from the reverse shaft (1). (4WD type only)

(When reassembling)

- After inserting the spring pin to the 1st shaft and drive shaft, lock the spring pin with a wire.

- (1) Reverse Shaft
- (2) 1st Shaft
- (3) Propeller Shaft
- (4) Drive Shaft

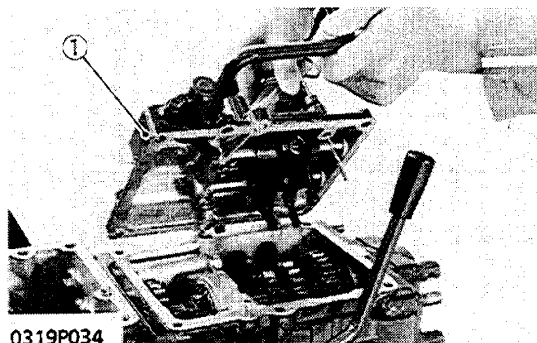

0319P034

Front Case Cover

1. Set the main speed change lever in neutral position, and remove the front case cover (1).

(When reassembling)

- Apply liquid gasket (Three Bond 1102 or equivalent) to the both sides of new gasket.

- (1) Front Case Cover

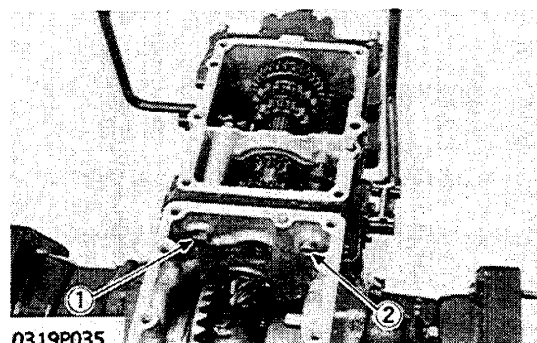

0319P035

Separating Transmission Case

1. Remove the bolt (1).
2. Remove the fork shaft lock screw (2).
3. Remove the transmission case mounting nuts, and separate the transmission case.

(When reassembling)

- Apply liquid gasket (Three Bond 1102 or equivalent) to the both sides of new gasket.

Tightening torque	Transmission case mounting nut	39.2 to 64.7 N·m 4.0 to 6.6 kgf·m 28.9 to 47.7 ft·lbs
-------------------	--------------------------------	---

- (1) Bolt
- (2) Fork Shaft Lock Screw

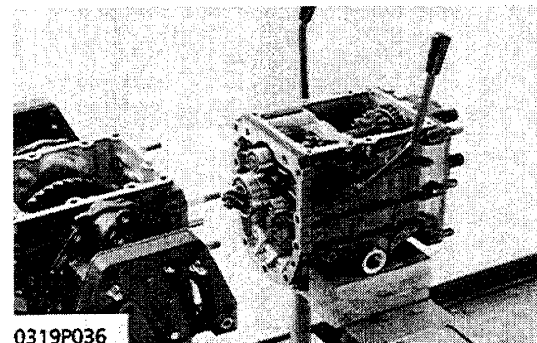

0319P036

[7] SEPARATING AXLE CASE FROM DIFFERENTIAL [GEAR TRANSMISSION TYPE]

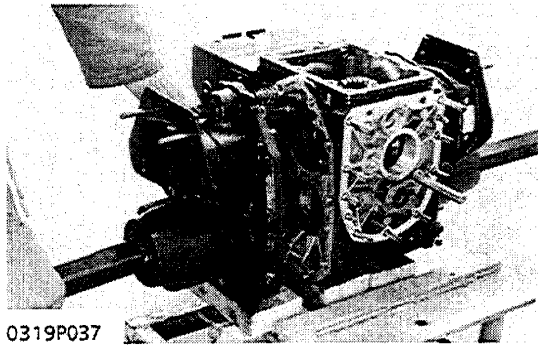

0319P037

Separating Rear Axle Case

1. Remove the rear axle case mounting screws, and separate the rear axle case.

(When reassembling)

- Be sure to replace the gasket with a new one.

Tightening torque	Rear axle case mounting screw	M10	39.2 to 64.7 N·m 4.0 to 6.6 kgf·m 28.9 to 47.7 ft-lbs
		M12	60.8 to 106.9 N·m 6.2 to 10.9 kgf·m 44.8 to 78.8 ft-lbs

[B1550HST-B1750HST]

[8] SEPARATING CLUTCH HOUSING FROM TRANSMISSION [HST TYPE]

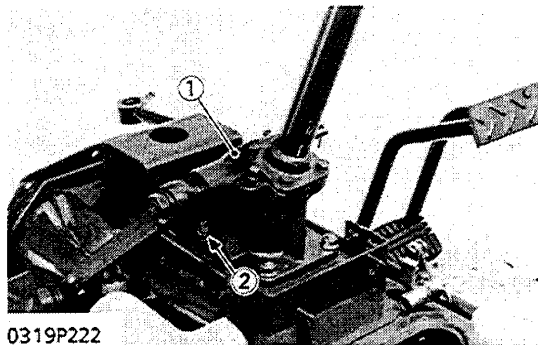

0319P222

Steering Assembly

1. Remove the slotted nut, and disconnect the drag link with a tie rod end lifter.
2. Remove the bonnet rear support in front of the steering assembly.
3. Disconnect the delivery pipe and return pipe for power steering from its valve. (If power steering equipped.)
4. Remove the steering gear box mounting nuts (2) and remove the steering assembly (1) from the clutch housing.

Tightening torque	Steering gear box mounting nut	39.2 to 64.7 N·m 4.0 to 6.6 kgf·m 28.9 to 47.7 ft-lbs
	Slotted nut	17.7 to 34.3 N·m 1.8 to 3.5 kgf·m 13.0 to 25.3 ft-lbs

(1) Steering Assembly

(2) Nut

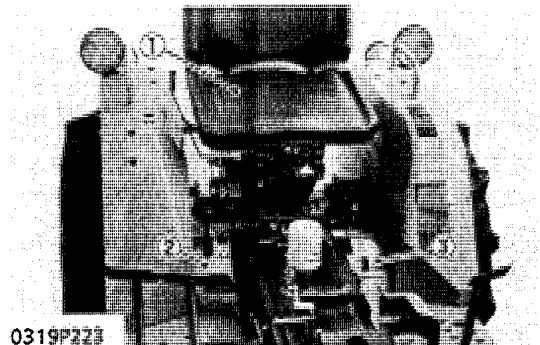

0319P223

Seat, Tires, Fenders and Covers

1. Remove the seat (1).
2. Remove the left and right tires.
3. Remove the wiring (5).
4. Remove the left and right covers (2) (3).
5. Remove the right fender (4) with the position control lever guide.
6. Remove the left fender with the fender stay and battery bracket (6).

Tightening torque	Rear wheel hub cotter 2 and nut	166.7 to 191.2 N·m 17.0 to 19.5 kgf·m 123.0 to 141.0 ft-lbs
-------------------	---------------------------------	---

(1) Seat

(4) Fender (RH)

(2) Cover (RH)

(5) Wiring

(3) Cover (LH)

(6) Battery Bracket

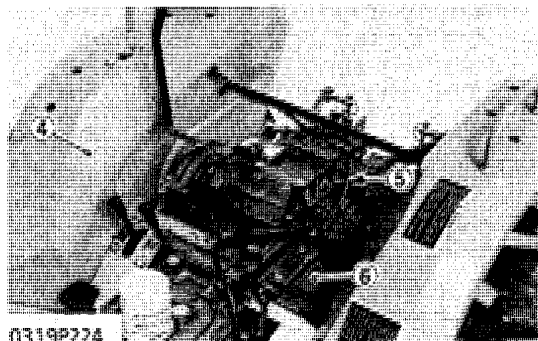

0319P224

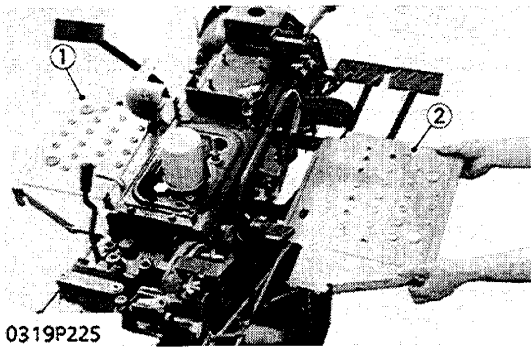

0319P225

Steps

1. Remove the cotter pins from both sides of step bracket under the steps.
2. Remove the left and right steps (1), (2).

(1) Step (LH)

(2) Step (RH)

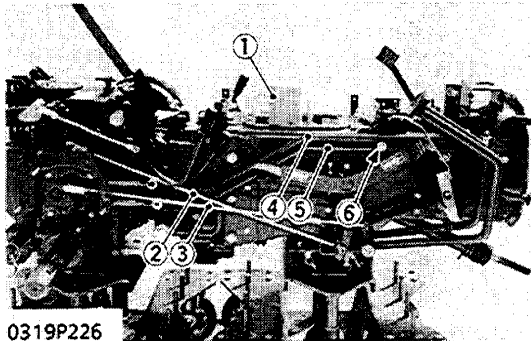

0319P226

Inlet Pipe, Delivery Pipe, Oil Filter and Rods

1. Remove the pipe clamp (6), and remove the inlet pipe (4) and delivery pipe (5).
2. Remove the oil filter (1).
2. Remove the left and right brake rods (3).
4. Remove the differential lock rod (2).
5. Remove the cotter pin (7), and remove the rod (8).

(When reassembling)

- Use care not to damage the O-rings on the inlet pipe.
- If loosen the turnbuckle during disassembly, adjust the length of brake rod. (See page S.G-12)

(1) Oil Filter

(5) Delivery Pipe

(2) Differential Lock Rod

(6) Pipe Clamp

(3) Brake Rod

(7) Cotter Pin

(4) Inlet Pipe

(8) Rod

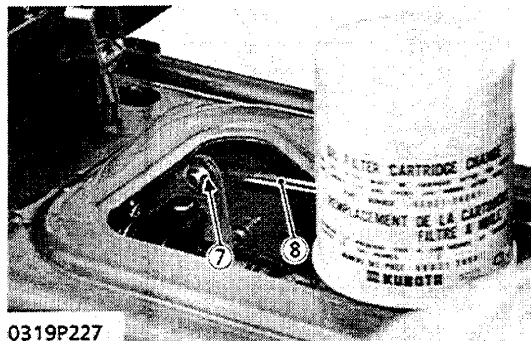

0319P227

Filter Joint, Eye Joint Bolt and Spring Tension Adjusting Bolt

1. Remove the filter joint (1), the eye joint bolt (2) and the hydraulic pipe.
2. Remove the lock nut (4), nut (5) and remove the spring and spring tension adjusting bolt (3).

(1) Filter Joint

(4) Lock Nut

(2) Eye Joint Bolt

(5) Nut

(3) Spring Tension Adjusting Bolt

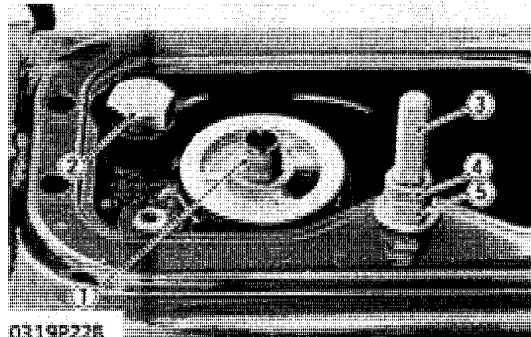

0319P228

Hydraulic Pipe and Connecting Plate

1. Loosen the hose clamp (3) and remove the hydraulic pipe (2).
2. Remove the connecting plate (1).

(1) Connecting Plate

(3) Clamp

(2) Hydraulic Pipe

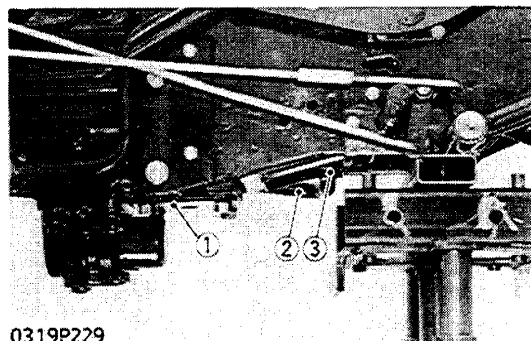

0319P229

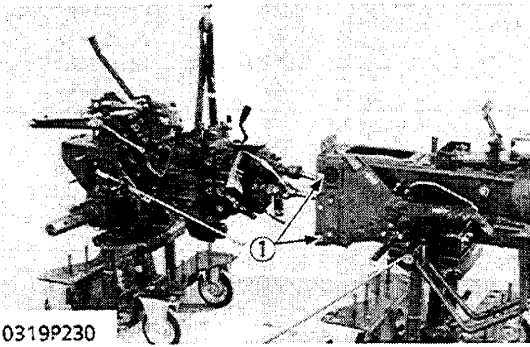

0319P230

(1) Reamer Bolt

Separating Clutch Housing

1. Remove the clutch housing mounting nuts, and separate the clutch housing.

(When reassembling)

- Replace the reamer bolts (1) at their original positions.

Tightening torque	Clutch housing mounting nut	41.2 to 58.8 N·m 4.2 to 6.0 kgf·m 30.4 to 43.4 ft-lbs
-------------------	-----------------------------	---

[9] SEPARATING HYDROSTATIC TRANSMISSION [HST TYPE]

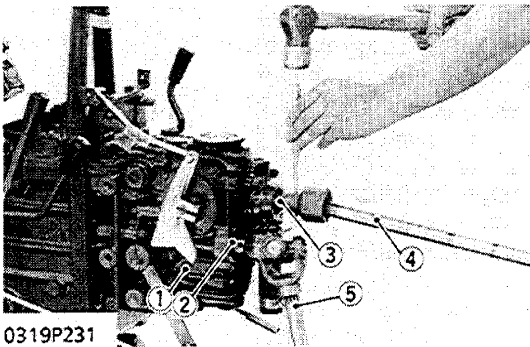

0319P231

(1) HST (2) Front Wheel Drive Shaft (3) 1st Shaft (4) Propeller Shaft (5) Drive Shaft

Hydrostatic Transmission (HST)

1. Remove the propeller shaft (4) from the 1st shaft (3).
2. Remove the drive shaft (5) from the front wheel drive shaft (2). (4WD type only)
3. Remove the HST mounting screws, and remove the HST (1).

(When reassembling)

- After inserting the spring pin to the 1st shaft and drive shaft, lock the spring pin with a wire.

Tightening torque	HST mounting screw	48.1 to 55.9 N·m 4.9 to 5.7 kgf·m 35.4 to 41.2 ft-lbs
-------------------	--------------------	---

[10] SEPARATING HYDRAULIC CYLINDER FROM DIFFERENTIAL [HST TYPE]

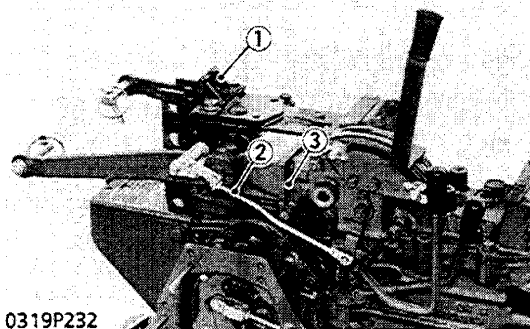

0319P232

(1) Top Link Bracket (2) Feedback Rod (3) Control Valve

Control Valve and Top Link Bracket

1. Remove the control valve (3) with the feedback rod (2).
2. Remove the top link bracket (1).

(When reassembling)

- Use care not to damage the O-rings on the control valve.

Tightening torque	Control valve mounting screw	16.7 to 21.6 N·m 1.7 to 2.2 kgf·m 12.3 to 15.9 ft-lbs
-------------------	------------------------------	---

Tightening torque	Top link bracket mounting screw	39.2 to 64.7 N·m 4.0 to 6.6 kgf·m 28.9 to 47.7 ft-lbs
-------------------	---------------------------------	---

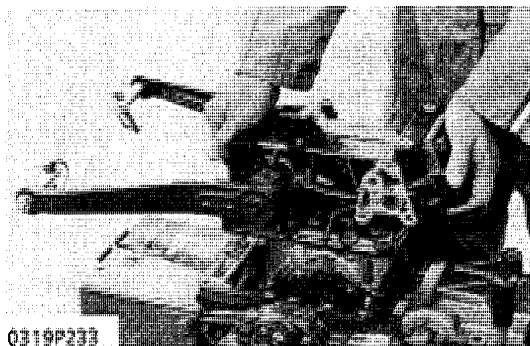

0319P233

Hydraulic Cylinder

1. Remove the hydraulic cylinder mounting screws, and separate the hydraulic cylinder.

(When reassembling)

- Be sure to replace the gasket with a new one.

Tightening torque	Hydraulic cylinder mounting screw	20.6 to 29.4 N·m 2.1 to 3.0 kgf·m 15.2 to 21.7 ft-lbs
-------------------	-----------------------------------	---

[11] SEPARATING TRANSMISSION CASE FROM DIFFERENTIAL GEAR CASE [HST TYPE]

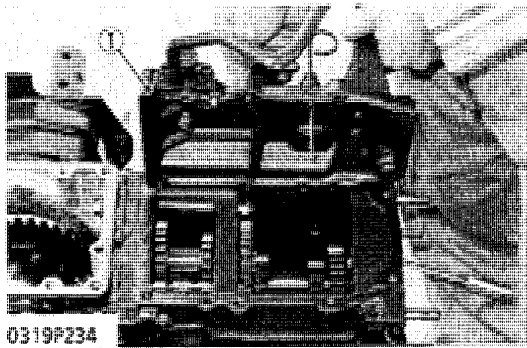

0319P234

Front Case Cover

1. Set the main speed change lever in neutral position, and remove the front case cover (1).

(When reassembling)

- Apply liquid gasket (Three Bond 1102 or equivalent) to the both sides of new gasket.

(1) Front Case Cover

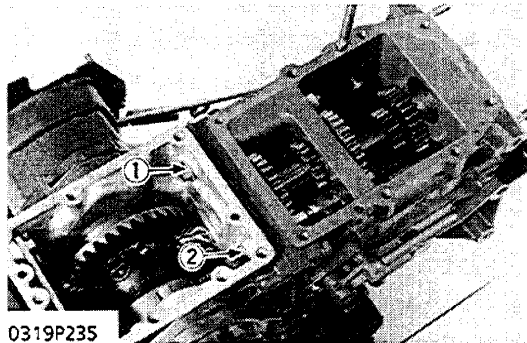

0319P235

Separating Transmission Case

1. Remove the bolt (1).
2. Remove the fork shaft lock screw (2).
3. Remove the transmission case mounting nuts, and separate the transmission case.

(When reassembling)

- Apply liquid gasket (Three Bond 1102 or equivalent) to the both sides of new gasket.

Tightening torque	Transmission case mounting nut	39.2 to 64.7 N·m 4.0 to 6.6 kgf·m 28.9 to 47.7 ft-lbs
-------------------	--------------------------------	---

(1) Bolt

(2) Fork Shaft Lock Screw

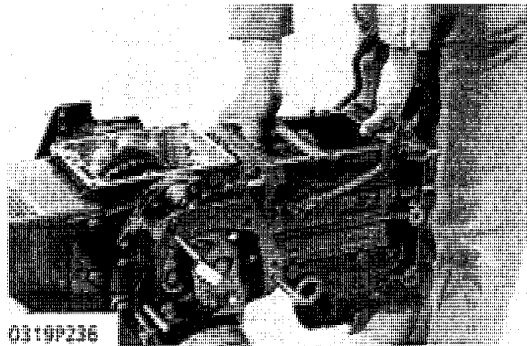

0319P236

[12] SEPARATING AXLE CASE FROM DIFFERENTIAL [HST TYPE]

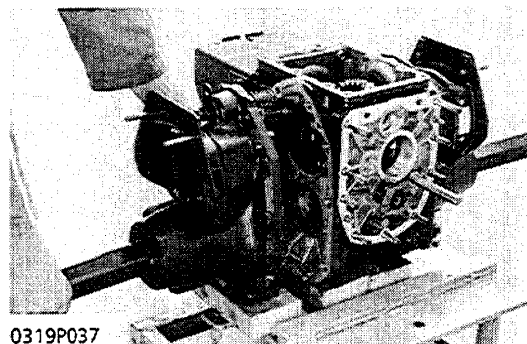

0319P037

Separating Rear Axle Case

1. Remove the rear axle case mounting screws, and separate the rear axle case.

(When reassembling)

- Be sure to replace the gasket with a new one.

Tightening torque	Rear axle case mounting screw	M10	39.2 to 64.7 N·m 4.0 to 6.6 kgf·m 28.9 to 47.7 ft-lbs
		M12	60.8 to 106.9 N·m 6.2 to 10.9 kgf·m 44.8 to 78.8 ft-lbs

DISASSEMBLING AND ASSEMBLING

[B2150-B2150HST]

[1] DRAINING COOLING WATER AND OIL

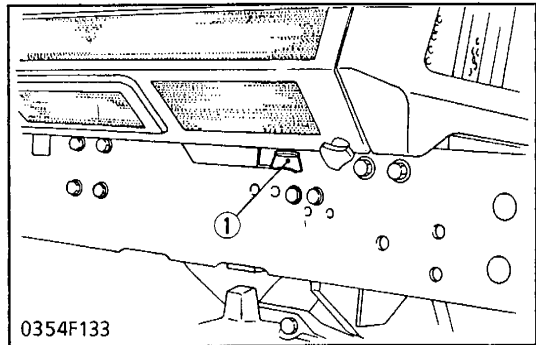

Draining Cooling Water

1. Remove the drain plug (1) from the radiator to drain cooling water.

Capacity	Coolant	B2150 B2150HST	3.9 ℓ 4.1 U.S. qts. 3.43 Imp. qts.

NOTE

- Remove the radiator cap to drain cooling water completely.

(1) Drain Plug

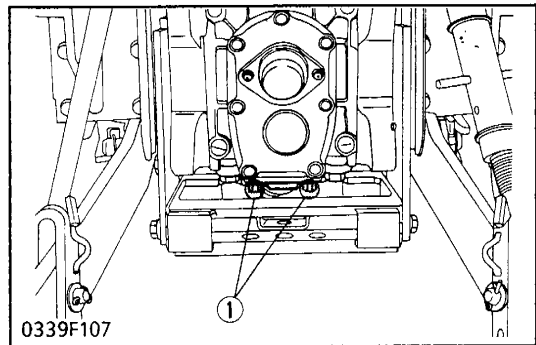

Draining Transmission Oil

1. Remove the drain plug (1), (2) to drain transmission oil.

Place	Model	Capacity	Lubricants	
			Maker	Brand (Standard)
Transmission	B2150 B2150HST	18 ℓ 19 U.S.qts 15.8 Imp.qts	KUBOTA	UDT hydrostatic transmission fluid
			Others	Refer to the table of "LUBRICANTS AND FLUID" in S.G-3

(1) Drain Plug

(2) Drain Plug

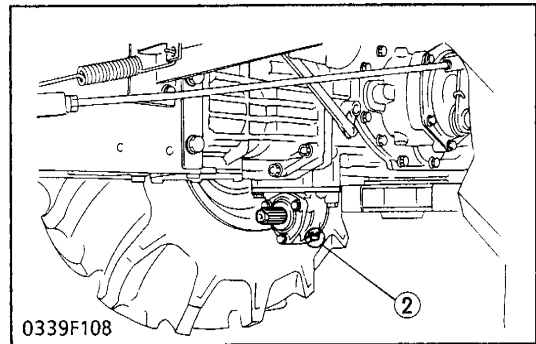

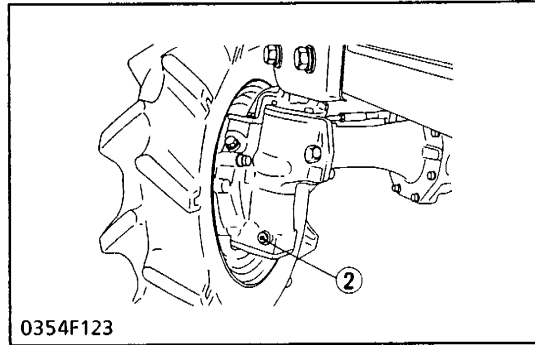
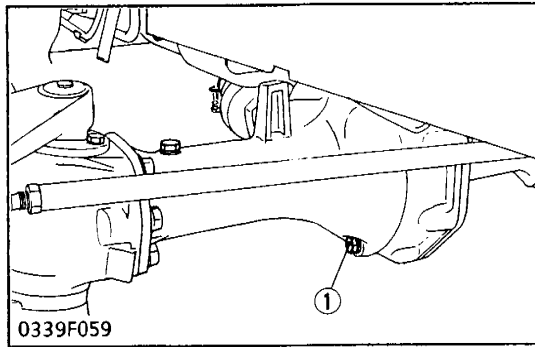

Draining Oil from Front Axle (4WD)

1. Remove the drain plug (1) to drain oil from the front axle differential case.
2. Remove the drain plugs (2) to drain oil from the right and left axle gear cases.

Place	Model	Capacity	Lubricants
Front axle diff. case	B2150 B2150HST	1.5 ℓ 1.6 U.S. qts. 1.3 Imp. qts.	Gear oil SAE 80 or SAE 90
Front axle gear case		0.5 ℓ x 2 0.5 U.S. qts. x 2 0.44 Imp. qts. x 2	

(1) Drain Plug

(2) Drain Plug

[2] SEPARATING FRONT AXLE FROM ENGINE

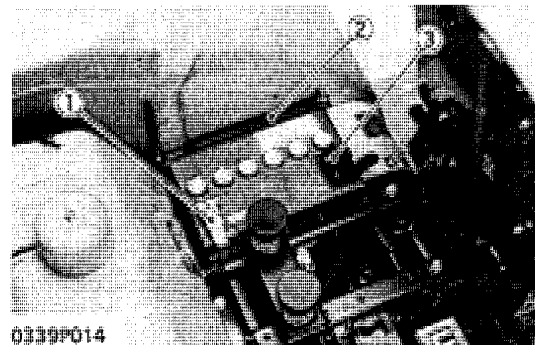

Battery

1. Remove the battery cover, and disconnect the battery cables.
2. Remove the battery support (2), and remove the battery.

NOTE

- Disconnect the ground terminal cable (-) (1) first for disconnection, and connect the positive terminal cable (+) (3) first for reassembly.

(1) Ground Terminal Cable

(3) Positive Terminal Cable

(2) Battery Support

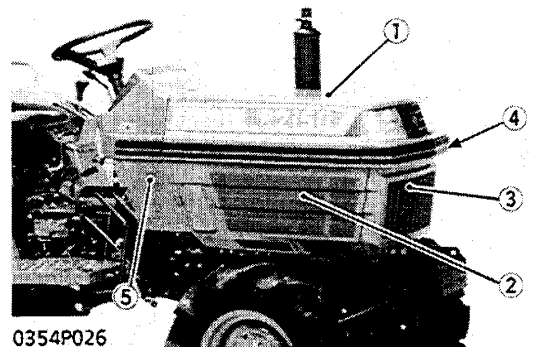

Hood and Skirts

1. Open the hood (1) from the front and remove the B-shape pins and hood link for keeping it open. And remove the hood (1).
2. Remove the right and left skirts (2), (4) with auxiliary skirt (LH). (After removing screws and sliding a little skirts forward, remove them.)
3. Remove the front skirt (3) by removing screws.
4. Remove both sides of dust cover (5) by removing screws.

(1) Hood

(4) Left Skirt

(2) Right Skirt

(5) Dust Cover

(3) Front Skirt

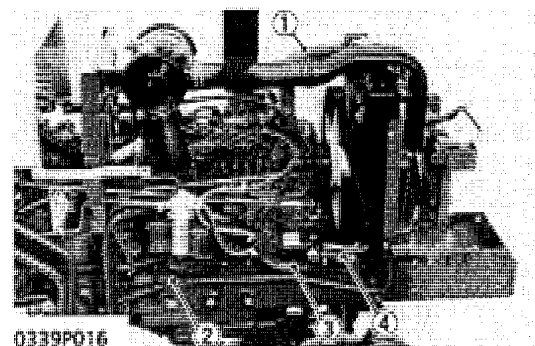

Radiator Hoses and Delivery Pipe

1. Loosen the clamps, and disconnect radiator hoses (1), (3) from radiator.
2. Loosen the clamps of delivery pipe (2) and radiator hose (4) from oil cooler. (HST type)

(1) Radiator Hose

(3) Radiator Hose

(2) Delivery Pipe

(4) Radiator Hose

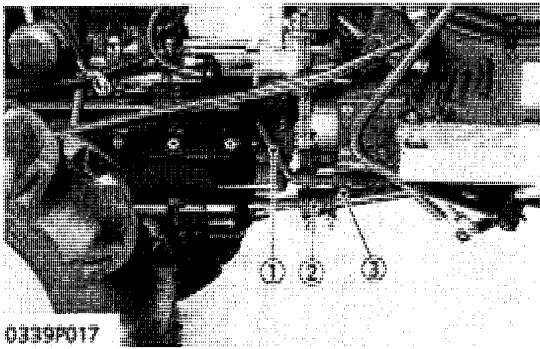

Protector Pipe and Suction Pipe

1. Loosen the clamps and slide the protector pipe (2) backward.
2. Loosen the clamp (3) of suction pipe (1) from oil cooler. (H.S.T. TYPE)

- (1) Suction Pipe (3) Clamp
 (2) Protector Pipe

0339P017

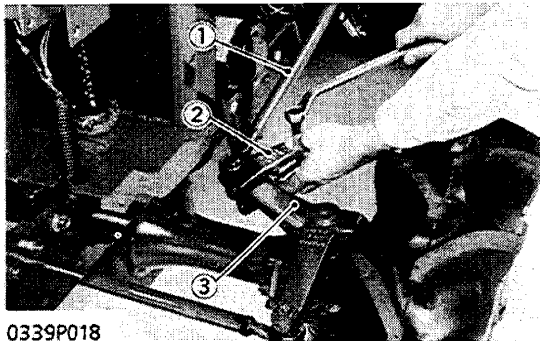

Drag Link

1. Steer the front wheels to the left.
2. Remove the slotted nut connecting the knuckle arm (3) and drag link (1), and disconnect the drag link at the front end with a tie rod end lifter (2) (Code No: 07909-39021).

(When reassembling)

Tightening torque	Front axle case mounting screw	48.1 to 55.9 N·m 4.9 to 5.7 kgf·m 35.4 to 41.2 ft-lbs
-------------------	--------------------------------	---

- (1) Drag Link (3) Knuckle Arm
 (2) Tie Rod End Lifter

0339P018

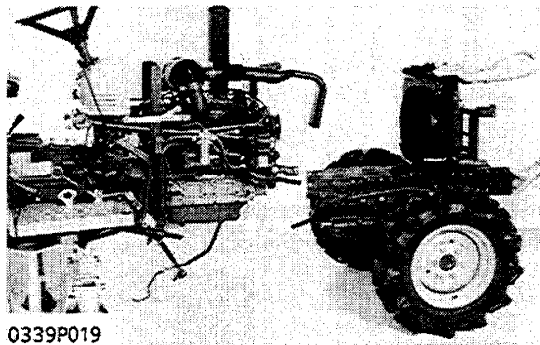

Separating Front Axle

1. Remove the front axle frame mounting screw and separate the front axle assembly from the engine.

(When reassembling)

- Correctly align the drive shaft and cross joint spline.

Tightening torque	Front axle frame mounting screw	48.1 to 55.9 N·m 4.9 to 5.7 kgf·m 35.4 to 41.2 ft-lbs
-------------------	---------------------------------	---

0339P019

[3] SEPARATING ENGINE FROM CLUTCH HOUSING

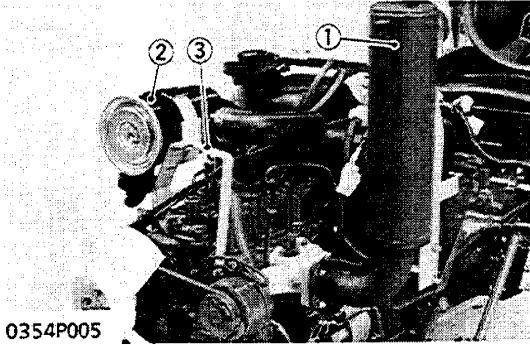

Muffler and Air Cleaner

1. Remove the air cleaner (2), air cleaner support (3) and inlet pipe.
2. Remove the muffler (1).

- | | |
|-----------------|-------------------------|
| (1) Muffler | (3) Air Cleaner Support |
| (2) Air Cleaner | |

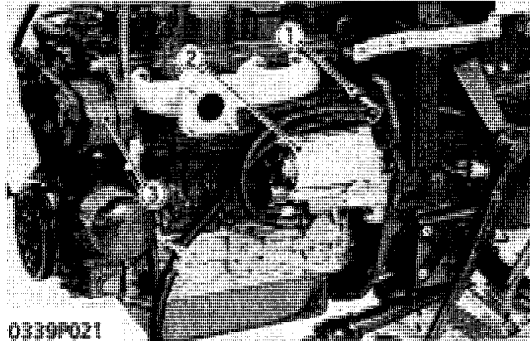

Starter and Wiring

1. Disconnect the wiring from the dynamo (3).
2. Disconnect the wiring from the oil switch (1).
3. Disconnect the wiring from the starter (2), and remove the starter from the engine.

- | | |
|----------------|------------|
| (1) Oil Switch | (3) Dynamo |
| (2) Starter | |

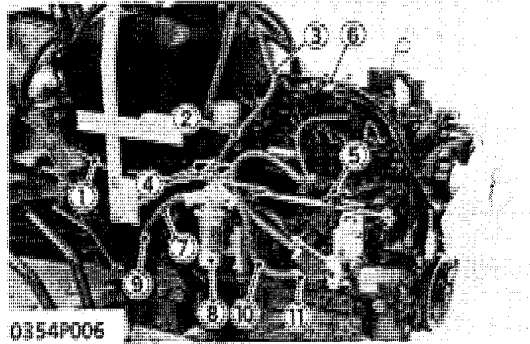

Rod, Cable, Filter and Fuel Pipes

1. Disconnect the accelerator rod (5) from the accelerator lever.
2. Disconnect the engine stop rod (1) from the stop lever.
3. Disconnect the hour meter cable (6).
4. Close the filter cock.
5. Loosen the clamps (3), (9) and (11).
6. Remove the mounting screws (4) and remove filter (8) with fuel pipes (2),(7) and (10).

- | | |
|----------------------|---------------|
| (1) Engine Stop Rod | (7) Fuel Pipe |
| (2) Fuel Pipe | (8) Filter |
| (3) Clamp | (9) Clamp |
| (4) Screws | (10) Pipe |
| (5) Accelerator Rod | (11) Clamp |
| (6) Hour Meter Cable | |

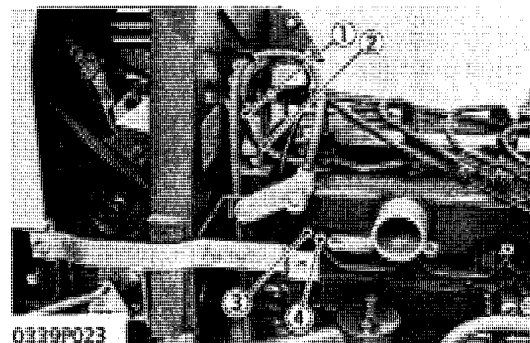

Wiring and Pipe

1. Disconnect the wiring (3) for the glow plug (4).
2. Disconnect wiring from the engine fuel cut off solenoid valve and from the coolant temperature gauge.
3. Disconnect wiring (2).
4. Disconnect fuel pipe (1) for fuel injector.

- | | |
|---------------|---------------|
| (1) Fuel Pipe | (3) Wiring |
| (2) Wiring | (4) Glow Plug |

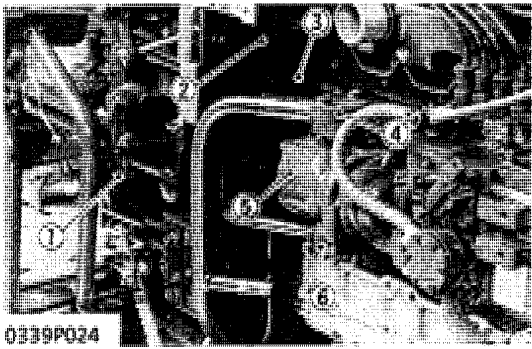

0339P024

Front Suction Pipe and Delivery Pipe

1. Disconnect the front suction pipe (4) and delivery pipe (6) from hydraulic pump (5).
2. Loosen the bolt (1).
3. Remove the cover and its support (2), (3).

(When reassembling)

Tightening torque	Delivery pipe mounting bolt (1)	53.9 to 68.6 N-m 5.5 to 7.0 kgf-m 39.8 to 50.6 ft-lbs
-------------------	---------------------------------	---

- (1) Bolt
- (2) Plate
- (3) Plate
- (4) Front Suction Pipe
- (5) Hydraulic Pump
- (6) Delivery Pipe

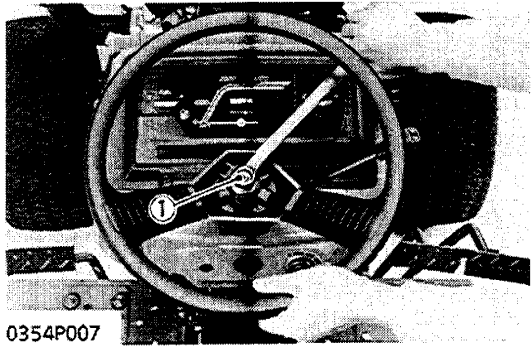

0354P007

Steering Wheel

1. Remove the steering wheel cap.
2. Loosen the steering wheel mounting nut (1) and pull the wheel with a steering wheel puller (Code No: 07916-51090).
3. Remove the steering wheel mounting nut, and pull out the steering wheel.

(When reassembling)

Tightening torque	Steering wheel mounting nut	29.4 to 49.0 N-m 3.0 to 5.0 kgf-m 21.7 to 36.1 ft-lbs
-------------------	-----------------------------	---

- (1) Steering Wheel Mounting Nut

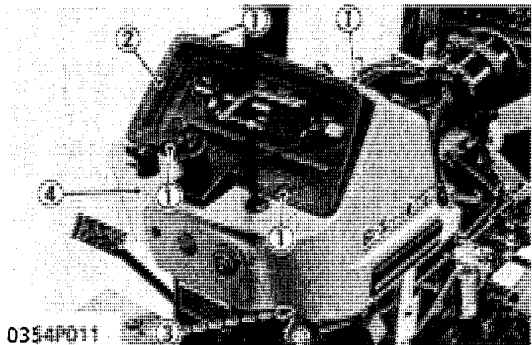

0354P011

Meter Panel

1. Remove the panel board screws (1) and disconnect the couplers and hour-meter cable from the body. And remove the panel board (2).
2. Disconnect the wiring harness from the timer relay, regulator, main switch, hazard switch and hazard unit.
3. Remove the meter panel mounting screws (3), and remove the meter panel (4).
4. Remove dust covers.

- (1) Panel Board Screws
- (2) Panel Board
- (3) Meter Panel Screws
- (4) Meter Panel

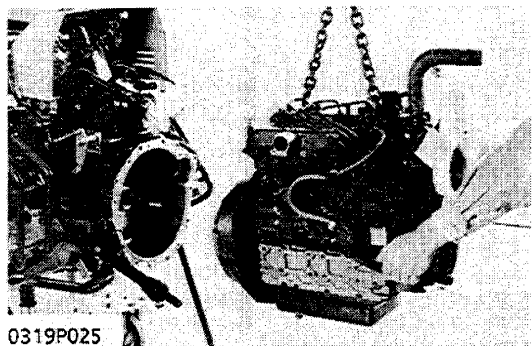

0319P025

Separating Engine

1. Remove the mounting screws and nuts, and separate the engine from the clutch housing.

(When reassembling)

Tightening torque	Engine mounting screw and nut	M10	48.1 to 55.9 N-m 4.9 to 5.7 kgf-m 35.4 to 41.2 ft-lbs
		M 8	23.5 to 27.5 N-m 2.4 to 2.8 kgf-m 17.4 to 20.2 ft-lbs

Go to the Section [7] in S.5-26 for B2150HST.

[B2150]

[4] SEPARATING CLUTCH HOUSING FROM TRANSMISSION
[GEAR TRANSMISSION TYPE]

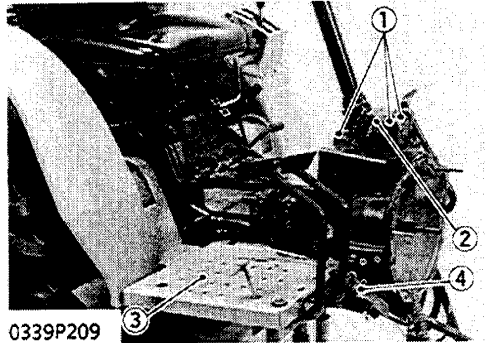

Steering Assembly with Pitman Arm and Step

1. Remove four nuts (1) mounting the steering assembly (2).
2. Remove the steering assembly (2) with the pitman arm.
3. Remove the right and left steps (3) with brake lock lever (4).

(When reassembling)

Tightening torque	Steering assembly mounting screw and nut	48.1 to 55.9 N·m 4.9 to 5.7 kgf·m 35.4 to 41.2 ft-lbs
-------------------	--	---

- | | |
|-----------------------|----------------------|
| (1) Nuts | (3) Step |
| (2) Steering Assembly | (4) Brake Lock Lever |

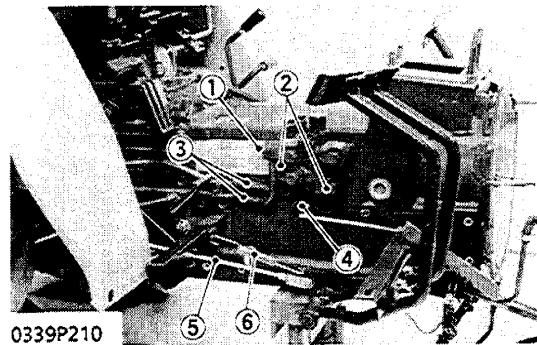

Brake Rod and Delivery Pipe

1. Unscrew joint bolts (1), (4) and remove pipes (3).
2. Remove the hydraulic block type outlet mounting screws (2).
3. Disconnect the brake rod (5) and spring (6) from the brake pedal.

(When reassembling)

Tightening torque	Hydraulic block type outlet mounting screw	17.7 to 20.6 N·m 1.8 to 2.1 kgf·m 13.0 to 15.2 ft-lbs
	Joint bolt	53.9 to 68.6 N·m 5.5 to 7.0 kgf·m 39.8 to 50.6 ft-lbs

- | | |
|----------------------------|-----------------|
| (1) Joint Bolts | (4) Joint Bolts |
| (2) Outlet Mounting Screws | (5) Brake Rod |
| (3) Pipes | (6) Spring |

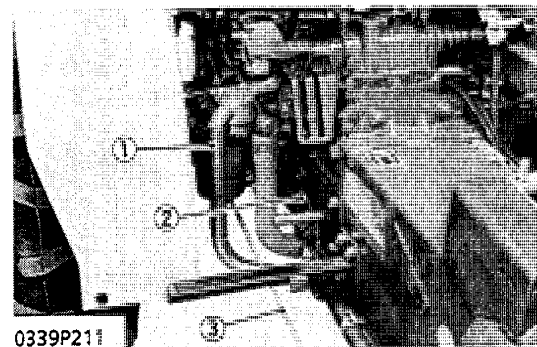

Rear Suction Pipe, Oil Strainer and Differential Lock Rod

1. Disconnect the differential lock rod (3).
2. Remove the fuel pipe (2) and rear suction pipe (1) with oil filter.

- | | |
|-----------------------|---------------------------|
| (1) Rear Suction Pipe | (3) Differential Lock Rod |
| (2) Fuel Pipe | |

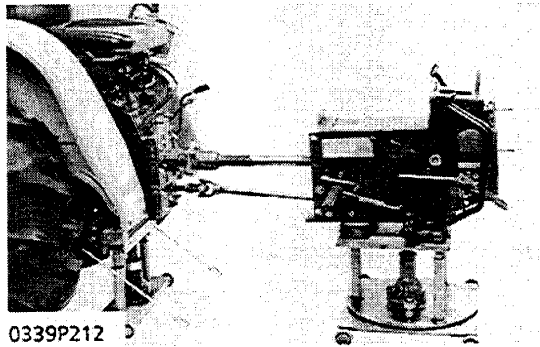

0339P212

Separating Clutch Housing

1. Remove the clutch housing mounting screws, right stay bolt and nuts, and separate the clutch housing from transmission.

(When reassembling)

- Replace the reamer screws (1) at their original positions.

Tightening torque	Clutch housing mounting screw	77.5 to 90.2 N·m 7.9 to 9.2 kgf·m 57.1 to 66.5 ft-lbs
-------------------	-------------------------------	---

(1) Reamer Screws

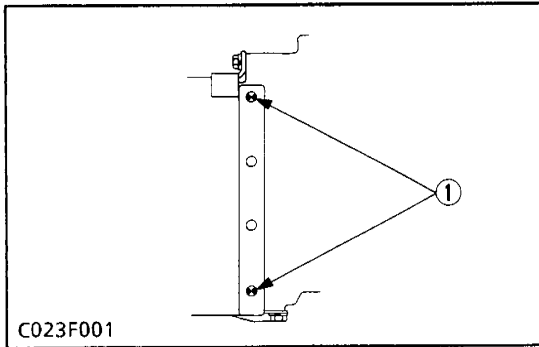

C023F001

[5] SEPARATING TRANSMISSION CASE FROM DIFFERENTIAL GEAR CASE [GEAR TRANSMISSION TYPE]

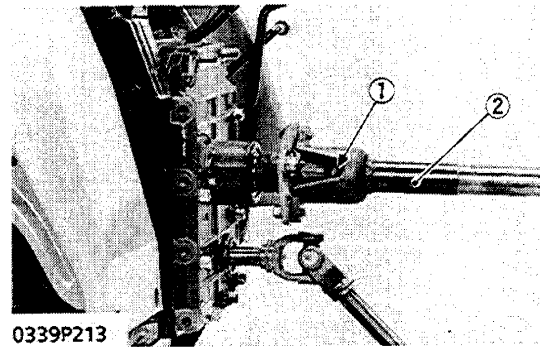

0339P213

Propeller Shaft and Drive Shaft

1. Tap out the spring pin (1) and pull out the propeller shaft (for PTO).
2. Remove the propeller shaft (outer shaft for traveling) (2) from the 1st shaft.
3. Remove the internal snap ring and coupling ball outer and tap out the spring pin.
4. Remove the flange.
5. Tap out the spring pin and remove the drive shaft from the front drive shaft.

(When reassembling)

- When inserting spring pins, face their splits in the direction at a right angle to the shaft as shown in the figure.

(1) Spring Pin

(2) Propeller Shaft

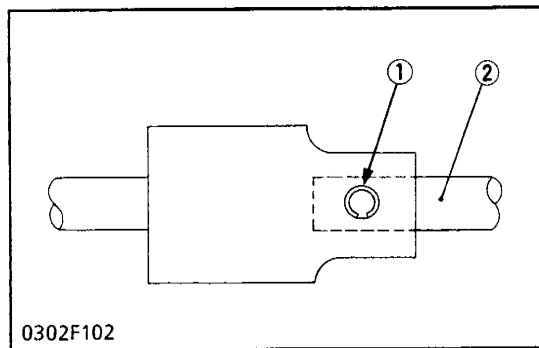

0302F102

Seat, Tires

1. Remove the seat (1).
2. Remove the right tire (2) and left tire.
3. Disconnect the wire for the hazard light.

(When reassembling)

Tightening torque	Rear wheel mounting screw and nut	196 to 294 N·m 20 to 30 kgf·m 145 to 166 ft-lbs
-------------------	-----------------------------------	---

(1) Seat

(2) Tire

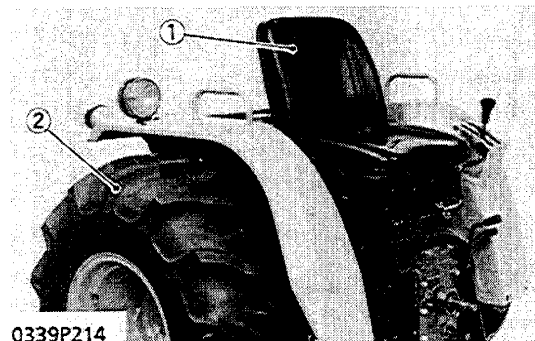

0339P214

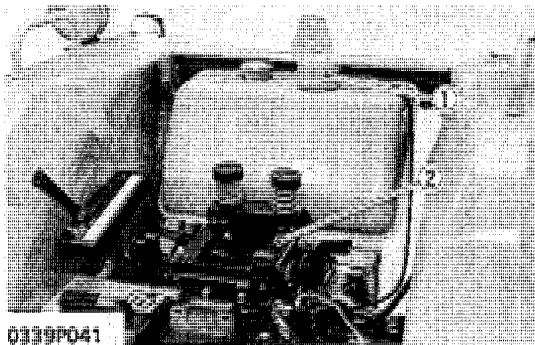

0339P041

Seat Adjuster and Fuel Tank

1. Remove the seat adjuster (2).
2. Remove the unit cover (1).
3. Disconnect the wiring (3) from the fuel unit.
4. Remove the fuel tank mounting screws (5), and remove the fuel tank (4).

- | | |
|-------------------|---------------|
| (1) Unit Cover | (4) Fuel Tank |
| (2) Seat Adjuster | (5) Screws |
| (3) Wiring | |

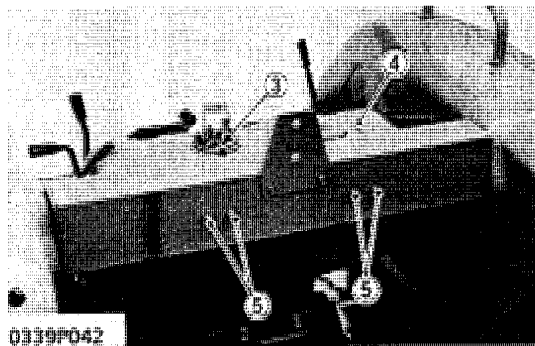

0339P042

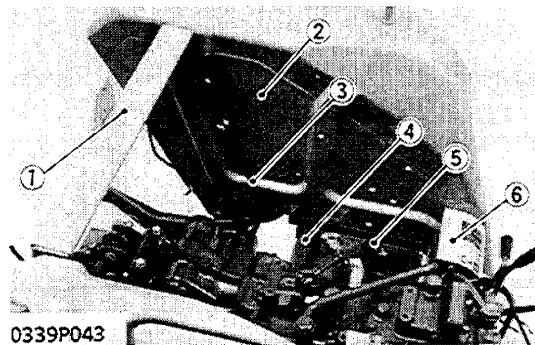

0339P043

Fenders

1. Remove the wiring (3), (5).
2. Remove the left fender mounting screws, and remove the fender (2) with battery bracket (4), fender stay (1) and change cover.
3. Remove the right fender mounting screws and remove the fender (7).

- | | |
|---------------------|---------------------|
| (1) Fender Stay | (5) Wiring |
| (2) Fender LH | (6) Change Cover LH |
| (3) Wiring | (7) Fender RH |
| (4) Battery Bracket | (8) Change Cover RH |

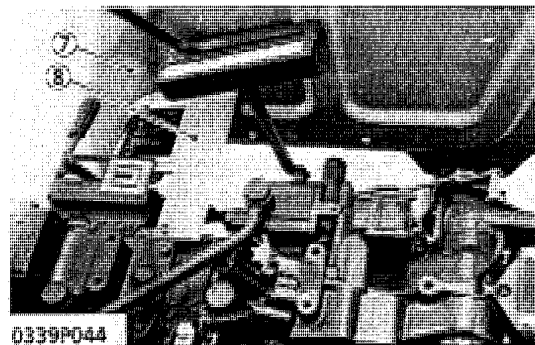

0339P044

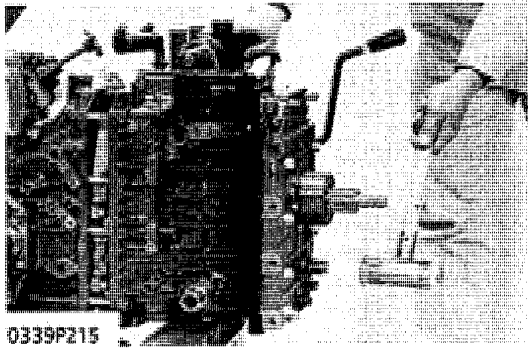

0339P215

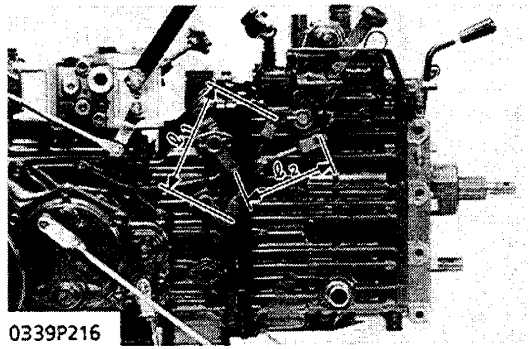

0339P216

Separating Transmission Case

1. Remove two right links and one left link for 4WD.
2. Remove the transmission case mounting screws and nuts, while tapping the front drive shaft with a soft hammer. Separate the transmission case.

(When reassembling)

Tightening torque	Transmission case mounting screw and nut	34.3 to 39.2 N·m 3.5 to 4.0 kgf·m 25.3 to 28.9 ft-lbs
-------------------	--	---

(Reference)

- When assembling the range selector rod, adjust the length l_1 and l_2 of the rod.

Length l_1 of range selector rod	148 mm, 5.83 in.
Length l_2 of range selector rod	81 mm, 3.19 in.

[6] SEPARATING AXLE CASE AND HYDRAULIC CYLINDER FROM DIFFERENTIAL GEAR CASE [GEAR TRANSMISSION TYPE]

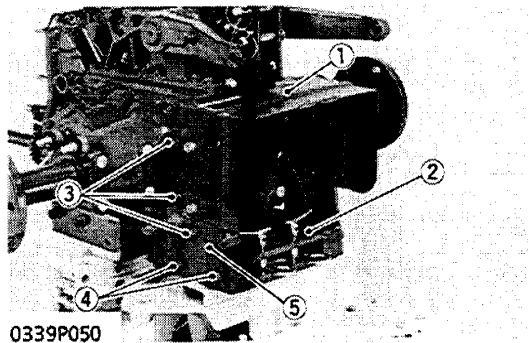

0339P050

- (1) PTO Master Shield
- (2) Hitch
- (3) Screws
- (4) Screws
- (5) Side Plate

Side Plates and Hitch

1. Remove the PTO master shield (1).
2. Remove the side plates (5) and hitch (2).

(When reassembling)

Tightening torque	Side plate mounting screw (3)	73..5 to 78.5 N·m 7.5 to 8.0 kgf·m 54.3 to 57.8 ft-lbs
	Side plate mounting screw (4)	77.5 to 90.2 N·m 7.9 to 9.2 kgf·m 57.2 to 66.5 ft-lbs
	Hitch mounting nut	73.5 to 78.5 N·m 7.5 to 8.0 kgf·m 54.3 to 57.8 ft-lbs

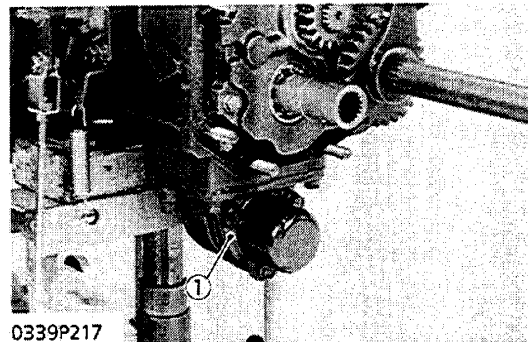

0339P217

- (1) Mid PTO Assembly

Mid PTO

1. Remove the drive case mounting screws, and remove the mid PTO assembly (1).

(When reassembling)

Tightening torque	Drive case mounting screw	48.1 to 55.9 N·m 4.9 to 5.7 kgf·m 35.4 to 41.2 ft-lbs
-------------------	---------------------------	---

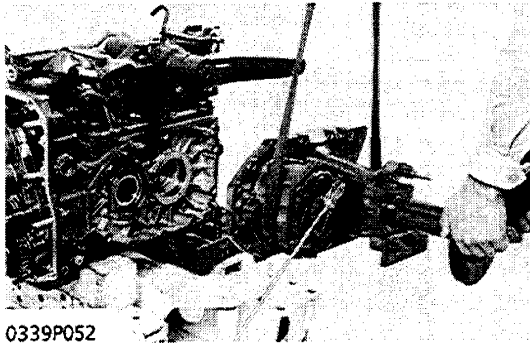

0339P052

Axle Case

1. Remove the axle case mounting screw and nuts, and separate the axle case from the differential gear case.

Tightening torque	Axle case mounting screw and nut	M10	34.3 to 39.2 N·m 3.5 to 4.0 kgf·m 25.3 to 28.9 ft-lbs
		M12	73.5 to 78.5 N·m 7.5 to 8.0 kgf·m 54.2 to 57.9 ft-lbs

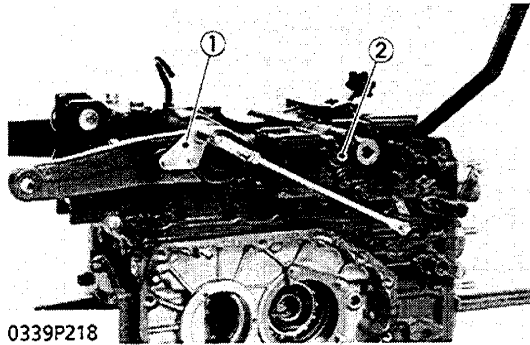

0339P218

(1) Holder (2) Control Valve

Control Valve

1. Disconnect the holder (1) from the lift arm RH..
2. Remove the control valve mounting screws, and separate the control valve (2) from the hydraulic cylinder.

(When reassembling)

- Use care not damage the O-ring.

Tightening torque	Control valve mounting screw	23.5 to 27.5 N·m 2.4 to 2.8 kgf·m 17.4 to 20.2 ft-lbs
-------------------	------------------------------	---

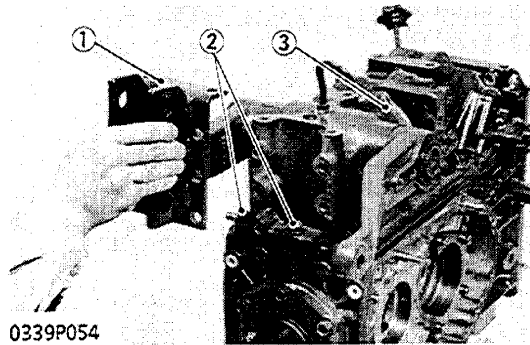

0339P054

(1) Top Link Bracket (2) Screw (3) Hydraulic Cylinder

Hydraulic Cylinder

1. Remove the top link bracket (1), and remove the cylinder mounting screws (2).
2. Remove the hydraulic cylinder mounting screws and nuts, and separate the hydraulic cylinder (3) from the differential gear case.

(When reassembling)

- When reassembling the hydraulic cylinder, use care not to allow the hydraulic piston rod to fall from the cylinder.

Tightening torque	Hydraulic cylinder mounting screw and nut	34.3 to 39.2 N·m 3.5 to 4.0 kgf·m 25.3 to 28.9 ft-lbs
	Top link bracket mounting screw	48.1 to 55.9 N·m 4.9 to 5.7 kgf·m 35.4 to 41.2 ft-lbs

[B2150HST]

[7] SEPARATING CLUTCH HOUSING FROM TRANSMISSION [HST TYPE]

Speed Set Device

1. Remove the speed set device cover (1).
2. Remove the spring lock pin from the rod (3) and remove the cotter pins from the speed release rod (5) and clevis pin (6).
3. Remove the nuts (2) and screws (4).
4. Move the speed set device assembly (7) to the direction of the arrow and remove it.

- | | |
|----------------------------|-------------------------|
| (1) Speed Set Device Cover | (4) Bracket |
| (2) Screws | (5) Speed Control Pedal |
| (3) Nut | |

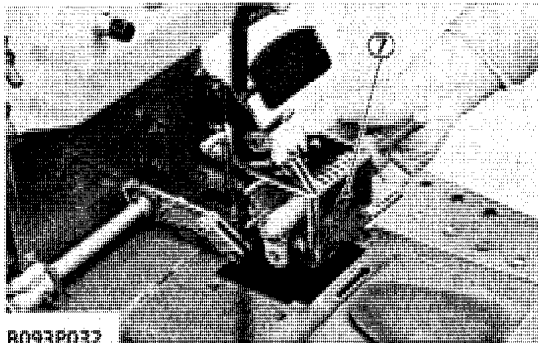
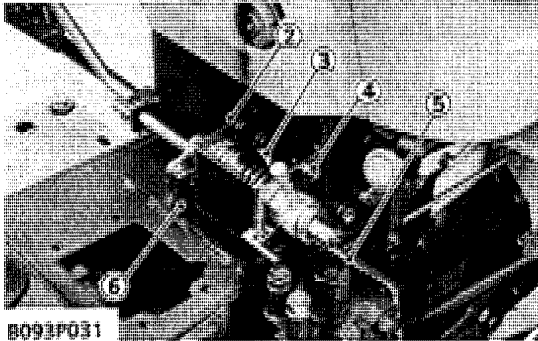
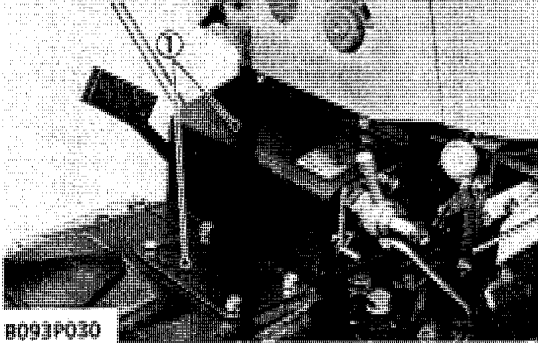

Pipes [Power Steering Type]

1. Remove four joint bolts (2), (3) and eight copper gaskets to remove the hydraulic pipes (1).

■ NOTE

- To avoid entering dust, screw the joint bolt (3) into the hydraulic block type outlet (4).

(When reassembling)

Tightening torque	Joint bolt	39.2 to 44.1 N·m 4.0 to 4.5 kgf·m 29.0 to 32.6 ft·lbs
-------------------	------------	---

- | | |
|----------------|---------------------------------|
| (1) Pipe | (3) Joint Bolt |
| (2) Joint Bolt | (4) Hydraulic Block Type Outlet |

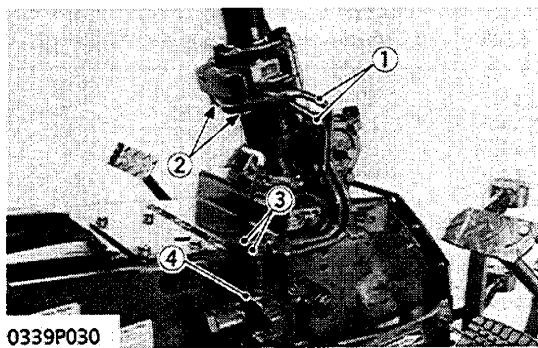

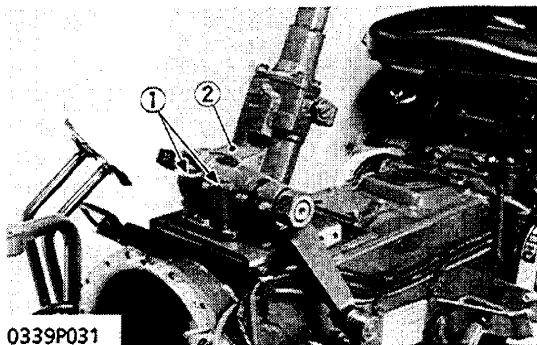

0339P031

Steering Assembly with Pitman Arm

1. Remove four nuts (1) mounting the steering assembly (2).
2. Remove the steering assembly (2) with the pitman arm.

(When reassembling)

Tightening torque	Steering assembly mounting nut	48.1 to 55.9 N·m 4.9 to 5.7 kgf·m 35.4 to 41.2 ft-lbs

- (1) Nuts (2) Steering Assembly

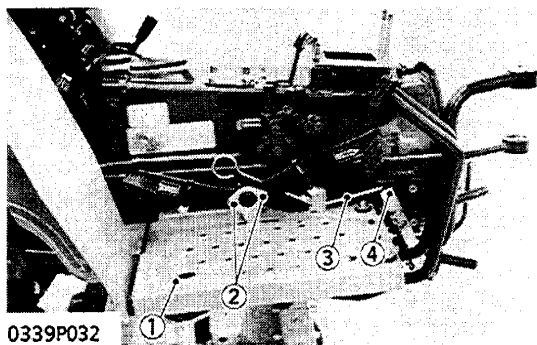

0339P032

Step

1. Remove the damper bracket mounting screws (2).
2. Remove the cotter pin (4).
3. Remove the right step (1) with parking brake rod (3).
4. Remove the left step.

- (1) Right Step (2) Screws (3) Parking Brake Rod (4) Cotter Pin

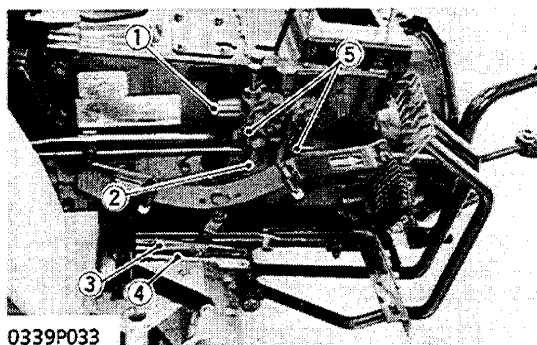

0339P033

Brake Rod and Delivery Pipe

1. Loosen the hydraulic block type outlet mounting screws (5).
2. Remove the joint bolts (1) (2).
3. Disconnect the brake rod (4) and spring (3) from the brake pedal.

(When reassembling)

Tightening torque	Hydraulic block type outlet mounting screw	17.7 to 20.6 N·m 1.8 to 2.1 kgf·m 13.0 to 15.2 ft-lbs
	Joint bolt	53.9 to 68.6 N·m 5.5 to 7.0 kgf·m 39.8 to 50.6 ft-lbs

- (1) Joint Bolt (long) (2) Joint Bolt (short) (3) Spring (4) Brake Rod (5) Screws

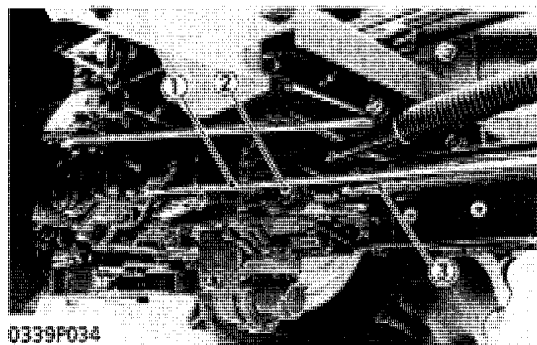

0339P034

Rear Suction Pipe, Oil Strainer and Differential Lock Rod

1. Disconnect the differential lock rod (1) from rear axle case.
2. Remove the oil strainer (2) to disconnect the rear suction pipe (3) from transmission case.

- (1) Differential Lock Rod (2) Oil Strainer (3) Rear Suction Pipe

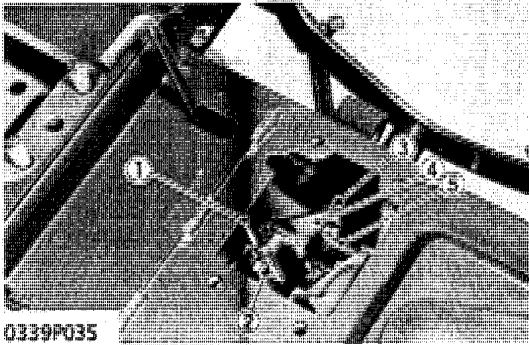

0339P035

Rod

1. Remove the spring lock pin (2) and remove the rod (1).
2. Remove the spring lock pin (3), and disconnect the speed control rod (5) from the rod guide (4).

- (1) Rod
- (2) Spring Lock Pin
- (3) Spring Lock Pin
- (4) Rod Guide
- (5) Speed Control Rod

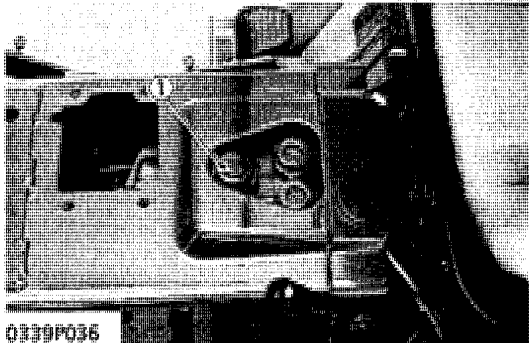

0339P036

Joint Bolt

1. Remove the rubber cover.
2. Remove the joint bolt (1) connecting the suction pipe and HST.
3. Remove the suction pipe.

(When reassembling)

Tightening torque	Joint bolt	53.9 to 68.6 N·m 5.5 to 7.0 kgf·m 39.8 to 50.6 ft-lbs
-------------------	------------	---

- (1) Joint Bolt

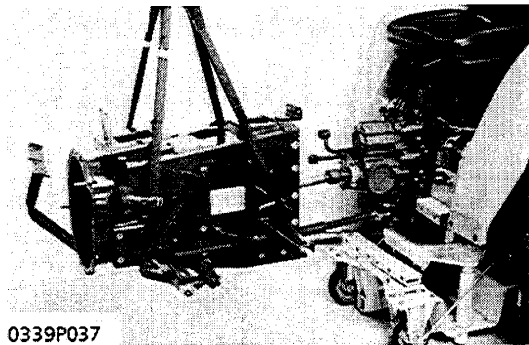

0339P037

Separating Clutch Housing

1. Remove the clutch housing mounting screws and nuts, and separate the clutch housing from transmission.

(When reassembling)

- Replace the reamer screws (1) at their original positions.

Tightening torque	Clutch housing mounting screw	77.5 to 90.2 N·m 7.9 to 9.2 kgf·m 57.1 to 66.5 ft-lbs
-------------------	-------------------------------	---

- (1) Reamer Screws

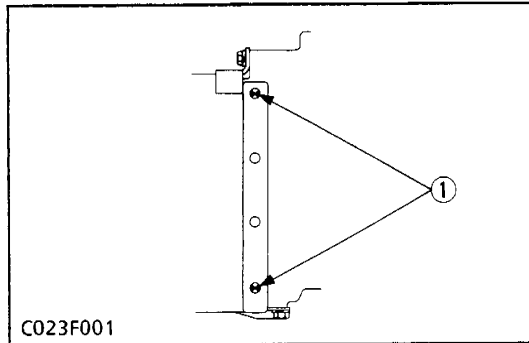

C023F001

[8] SEPARATING TRANSMISSION CASE FROM DIFFERENTIAL GEAR CASE [HST TYPE]

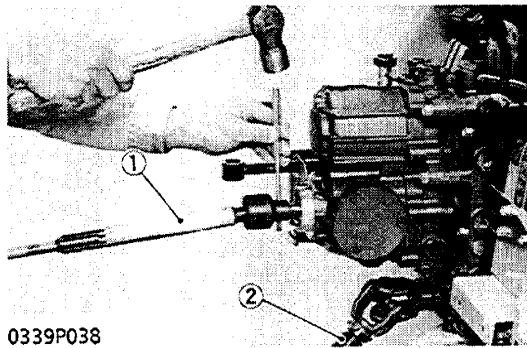

Propeller Shaft and Drive Shaft

1. Remove the propeller shaft (1) from the 1st shaft.
2. Remove the drive shaft (2) from the front drive shaft.

(When reassembling)

- When inserting spring pins, face their splits in the direction at a right angle to the shaft as shown in the figure.

(1) Propeller Shaft

(2) Drive Shaft

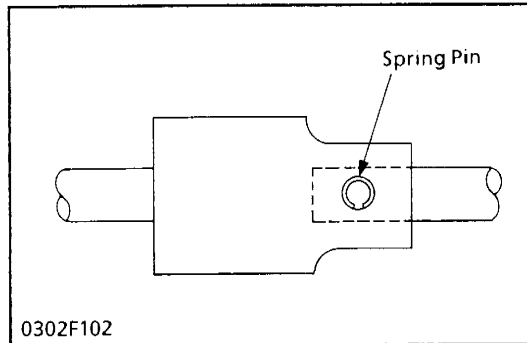

Hydrostatic Transmission (HST)

1. Remove the hydrostatic transmission mounting screws, and remove the hydrostatic transmission.

Tightening torque	Hydrostatic transmission mounting screw	48.1 to 55.9 N·m 4.9 to 5.7 kgf·m 35.4 to 41.2 ft-lbs
-------------------	---	---

(1) Hydrostatic Transmission

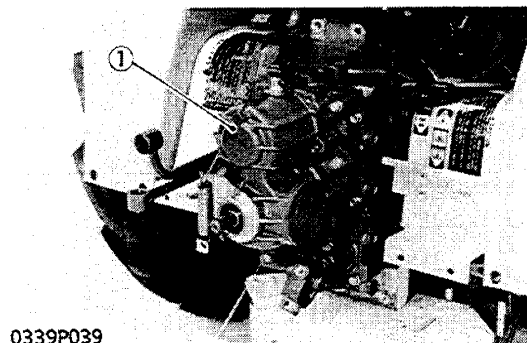

Seat and Tires

1. Remove the seat (1).
2. Remove the right tire and left tire (2).

(When reassembling)

Tightening torque	Rear wheel mounting screw and nut	196 to 294 N·m 20 to 30 kgf·m 145 to 166 ft-lbs
-------------------	-----------------------------------	---

(1) Seat

(2) Tire

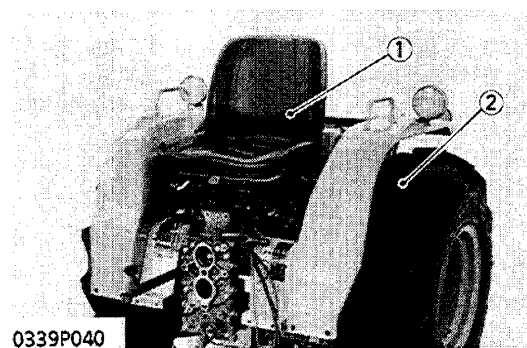

Seat Adjuster and Fuel Tank

1. Remove the seat adjuster (2).
2. Remove the unit cover (1).
3. Disconnect the wiring (3) from the fuel unit.
4. Remove the fuel tank mounting screws (5), and remove the fuel tank (4).

- (1) Unit Cover
- (2) Seat Adjuster
- (3) Wiring
- (4) Fuel Tank
- (5) Screws

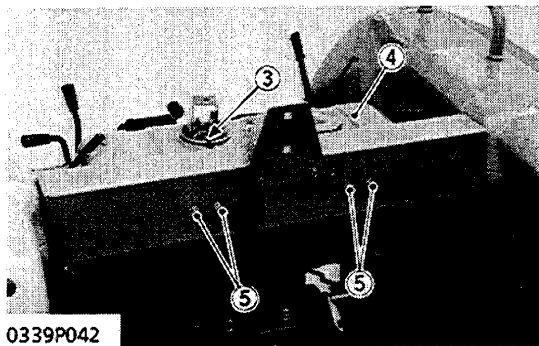
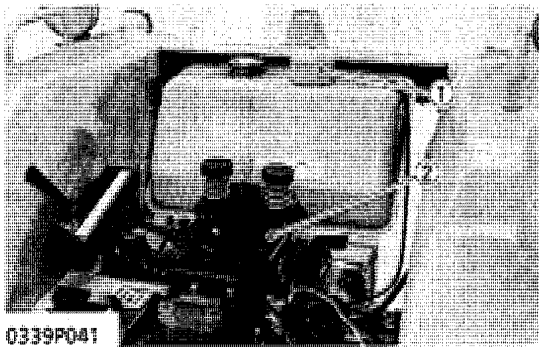

Fenders

1. Remove the wiring (3), (5).
2. Remove the left fender mounting screws, and remove the fender (2) with battery bracket (4), fender stay (1) and change cover (6).
3. Remove the right fender mounting screws and remove the fender (7) with change cover (8).

- (1) Fender Stay
- (2) Fender LH
- (3) Wiring
- (4) Battery Bracket
- (5) Wiring
- (6) Change Cover LH
- (7) Fender RH
- (8) Change Cover RH

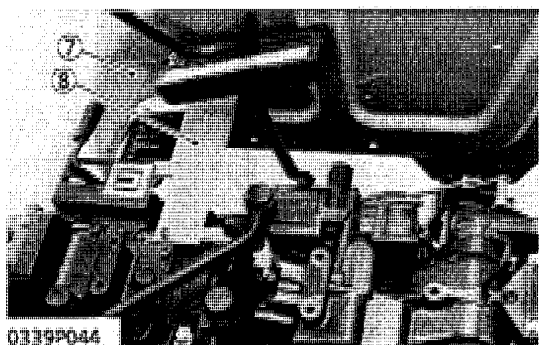
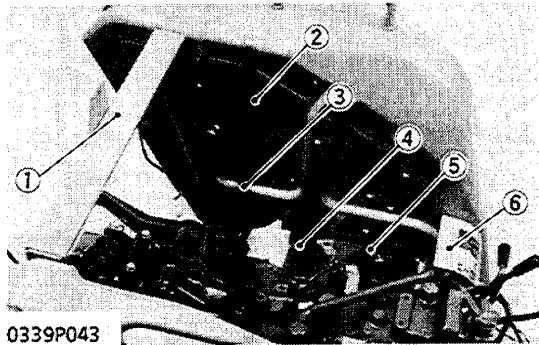

Oil Filter and Linkage

1. Remove the joint bolts (1) (4) to remove the oil filter (3) and pipe (2), (5).
2. Disconnect the linkage (6) from the differential case.

(When reassembling)

Tightening torque	Joint bolt	53.9 to 68.6 N·m 5.5 to 7.0 kgf·m 39.8 to 50.6 ft·lbs
-------------------	------------	---

- (1) Joint Bolt
- (2) Charge Pipe
- (3) Oil Filter
- (4) Joint Bolt
- (5) Charge Pipe
- (6) Front Drive Linkage

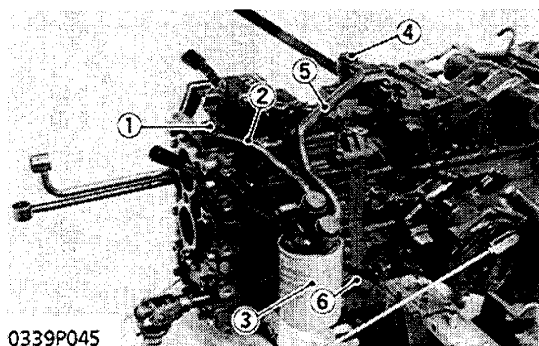

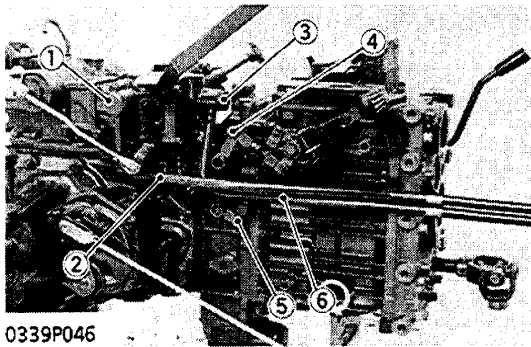

0339P046

Delivery Pipe and Return Pipe

1. Remove the joint bolt (1) to remove the delivery pipe (2).
2. Remove the joint bolt (3) to remove the return pipe (6).
3. Remove the cotter pins (4), (5) to separate the transmission case from the differential case.

(When reassembling)

Tightening torque	Joint bolt	53.9 to 68.6 N·m 5.5 to 7.0 kgf·m 39.8 to 50.6 ft·lbs
-------------------	------------	---

- | | |
|-------------------|-----------------|
| (1) Joint Bolt | (4) Cotter Pin |
| (2) Delivery Pipe | (5) Cotter Pin |
| (3) Joint Bolt | (6) Return Pipe |

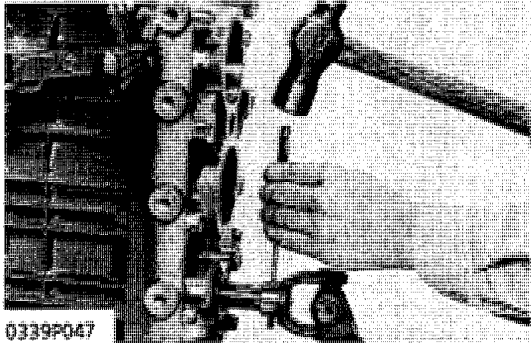

0339P047

Separating Transmission Case

1. Remove the joint from the 1st shaft.
2. Remove the transmission case mounting screws and nuts. While tapping the front drive shaft with a soft hammer, separate the transmission case.

(When reassembling)

Tightening torque	Transmission case mounting screw and nut	34.3 to 39.2 N·m 3.5 to 4.0 kgf·m 25.3 to 28.9 ft·lbs
-------------------	--	---

(Reference)

- When assembling the range selector rod, adjust the length l_1 and l_2 of the rod.

Length l_1 of range selector rod	148 mm, 5.83 in.
Length l_2 of range selector rod	81 mm, 3.19 in.

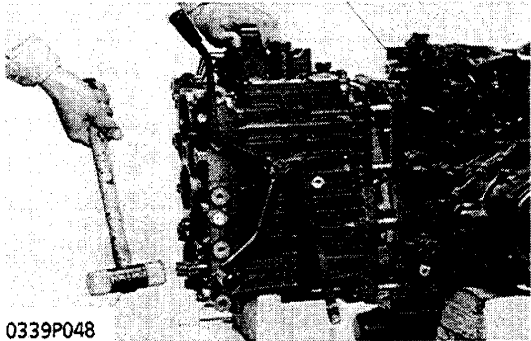

0339P048

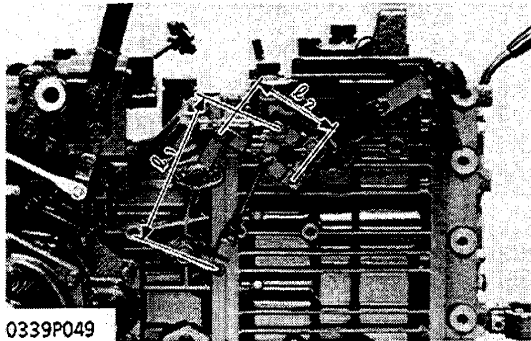

0339P049

[9] SEPARATING AXLE CASE AND HYDRAULIC CYLINDER FROM DIFFERENTIAL GEAR CASE [HST TYPE]

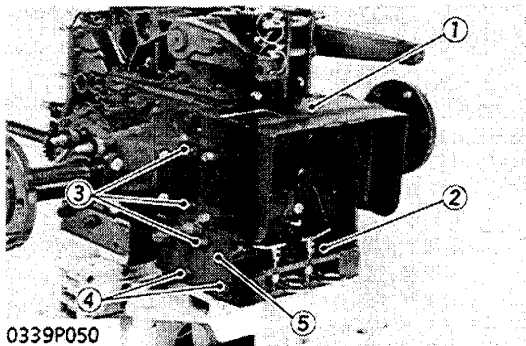

0339P050

- (1) PTO Master Shield
- (2) Hitch
- (3) Screws
- (4) Screws
- (5) Side Plate

Side Plates and Hitch

1. Remove the PTO master shield (1).
2. Remove the side plates (5) and hitch (2).

(When reassembling)

Tightening torque	Side plate mounting screw (3)	73.5 to 78.5 N·m 7.5 to 8.0 kgf·m 54.3 to 57.8 ft-lbs
	Side plate mounting screw (4)	77.5 to 90.2 N·m 7.9 to 9.2 kgf·m 57.2 to 66.5 ft-lbs
	Hitch mounting screw	73.5 to 78.5 N·m 7.5 to 8.0 kgf·m 54.3 to 57.8 ft-lbs

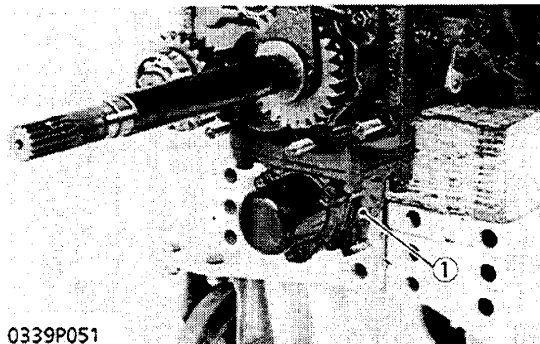

0339P051

- (1) Mid PTO Assembly

Mid PTO

1. Remove the drive case mounting screws, and remove the mid PTO assembly (1).

(When reassembling)

Tightening torque	Drive case mounting screw	48.1 to 55.9 N·m 4.9 to 5.7 kgf·m 35.4 to 41.2 ft-lbs
-------------------	---------------------------	---

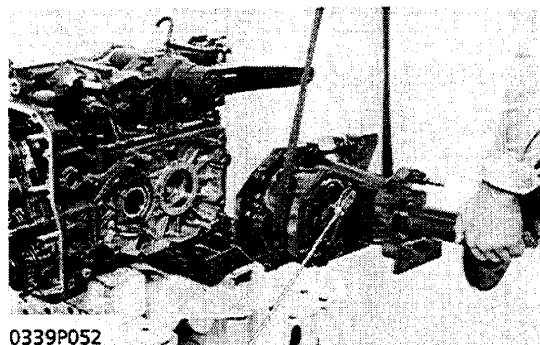

0339P052

Axle Case

1. Remove the axle case mounting screw and nuts, and separate the axle case from the differential gear case.

(When reassembling)

Tightening torque	Axle case mounting screw and nut	M10	34.3 to 39.2 N·m 3.5 to 4.0 kgf·m 25.3 to 28.9 ft-lbs
		M12	73.5 to 78.5 N·m 7.5 to 8.0 kgf·m 54.2 to 57.9 ft-lbs

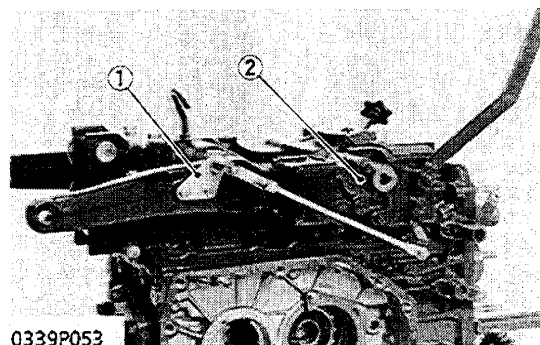

0339P053

Control Valve

1. Disconnect the holder (1) from the lift arm RH.
2. Remove the control valve mounting screws, and separate the control valve (2) from the hydraulic cylinder.

(When reassembling)

- Use care not damage the O-ring.

Tightening torque	Joint bolt	23.5 to 27.5 N·m 2.4 to 2.8 kgf·m 17.4 to 20.2 ft-lbs
-------------------	------------	---

(1) Holder

(2) Control Valve

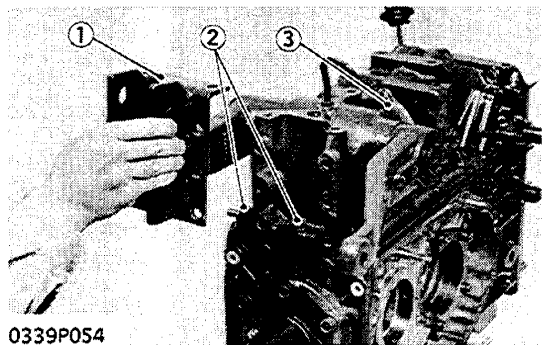

0339P054

(1) Top Link Bracket
(2) Screw

(3) Hydraulic Cylinder

Hydraulic Cylinder

1. Remove the top link bracket (1), and remove the cylinder mounting screw (2).
2. Remove the hydraulic cylinder mounting screws and nuts, and separate the hydraulic cylinder (3) from the differential gear case.

(When reassembling)

- When reassembling the hydraulic cylinder, use care not to allow the hydraulic piston rod to fall from the cylinder.

Tightening torque	Hydraulic cylinder mounting screw and nut	34.3 to 39.2 N·m 3.5 to 4.0 kgf·m 25.3 to 28.9 ft-lbs
	Top link bracket mounting screw	48.1 to 55.9 N·m 4.9 to 5.7 kgf·m 35.4 to 41.2 ft-lbs

CONTENTS

TROUBLESHOOTING	S.1-1
SERVICING SPECIFICATIONS	S.1-4
TIGHTENING TORQUES	S.1-11
CHECKING, DISASSEMBLING AND ASSEMBLING	S.1-12
[1] ENGINE BODY	
CHECKING AND ADJUSTING	S.1-12
DISASSEMBLING AND ASSEMBLING	S.1-14
(1) Cylinder Head	S.1-14
(2) Gear Case	S.1-17
(3) Camshaft and Fuel Camshaft	S.1-19
(4) Piston and Connecting Rod	S.1-21
(5) Starter, Flywheel and Crankshaft	S.1-25
SERVICING	S.1-28
(1) Cylinder Head	S.1-28
(2) Timing Gear and Camshaft	S.1-33
(3) Piston and Connecting Rod	S.1-35
(4) Crankshaft	S.1-37
(5) Cylinder Liner	S.1-41
[2] LUBRICATING SYSTEM	
CHECKING	S.1-42
DISASSEMBLING AND ASSEMBLING	S.1-42
SERVICING	S.1-43
[3] COOLING SYSTEM	
CHECKING	S.1-44
DISASSEMBLING AND ASSEMBLING	S.1-45
[4] FUEL SYSTEM	
CHECKING AND ADJUSTING	S.1-46
(1) Injection Pump	S.1-46
(2) Injection Nozzle	S.1-48
DISASSEMBLING AND ASSEMBLING	S.1-49
(1) Injection Nozzle	S.1-49

Sympton	Probable Cause	Solution	Reference Page
Either Black or Dark Gray Exhaust Gas Is Observed	<ul style="list-style-type: none"> ● Overload ● Low grade fuel used ● Fuel filter clogged ● Air cleaner clogged 	Lessen the load Use the specified fuel Clean or Replace Clean or Replace	— S.G-20 S.G-9 S.G-9, 10
Deficient Output	<ul style="list-style-type: none"> ● Incorrect injection timing ● Engine's moving parts seem to be seizing ● Uneven fuel injection ● Deficient nozzle injection ● Compression leak 	Adjust Repair or Replace Repair or Replace injection pump Repair or Replace nozzle Check compression pressure	S.1-46 — S.1-48 S.1-49 S.1-12
Excessive Lubricant Oil Consumption	<ul style="list-style-type: none"> ● Piston ring's gap facing the same direction ● Oil ring worn or stuck ● Piston ring groove worn ● Valve stem and guide worn ● Crankshaft bearing, and crank pin bearing worn 	Shift ring gap direction Replace Replace piston Replace Replace	S.1-23 S.1-36 S.1-37 S.1-30 S.1-37
Fuel Mixed into Lubricant Oil	<ul style="list-style-type: none"> ● Injection pump's plunger worn ● Fuel lift pump broken 	Replace pump element or pump Replace	S.1-47 S.1-17
Water Mixed into Lubricant Oil	<ul style="list-style-type: none"> ● Head gasket defective ● Cylinder block or cylinder head flawed 	Replace Replace or Repair	S.1-16 S.1-28, 29
Low Oil Pressure	<ul style="list-style-type: none"> ● Engine oil insufficient ● Oil strainer clogged ● Oil filter cartridge clogged ● Relief valve stuck with dirt ● Relief valve spring weaken or broken ● Excessive oil clearance of crankshaft bearing ● Excessive oil clearance of crank pin bearing ● Excessive oil clearance of rocker arm ● Oil passage clogged ● Different type of oil ● Oil pump defective 	Replenish Clean Replace Clean Replace Replace Replace Replace Clean Use the specified type of oil Repair or Replace	S.G-6 S.1-21 S.G-6, 14 — — S.1-37 S.1-38 S.1-32 — S.G-3 — S.1-43
High Oil Pressure	<ul style="list-style-type: none"> ● Different type of oil ● Relief valve defective 	Use the specified type of oil Replace	S.G-3 —

Symptom	Probable Cause	Solution	Reference Page
Engine Overheated	<ul style="list-style-type: none"> ● Engine oil insufficient ● Fan belt broken or tensioned improperly ● Cooling water insufficient ● Radiator net and radiator fin clogged with dust ● Inside of radiator corroded ● Cooling water flow route corroded ● Radiator cap defective ● Radiator hose damaged ● Thermostat defective ● Water pump defective ● Mechanical seal defective ● Overload running ● Head gasket defective ● Incorrect injection timing ● Unsuitable fuel used 	Replenish Replace or Adjust Replenish Clean Clean or Replace Clean or Replace Replace Replace Replace Replace Replace Loosen the load Replace Adjust Use the specified fuel	S.G-6 S.1-44 S.G-17 S.G-18, 19 S.G-18 S.G-18 S.1-44 S.G-14 S.1-44 S.1-45 S.1-45 — S.1-16 S.1-46 S.G-20
Battery Quickly Discharge	<ul style="list-style-type: none"> ● Battery fluid insufficient ● Fan belt slips ● Wiring disconnected ● Regulator defective ● AC dynamo defective ● Battery defective 	Replenish distilled water and Charge Adjust belt tension or Replace Connect Replace Replace Replace	S.G-13 S.1-44 M.9-2, 4 S.9-22 S.9-22 S.9-5, 6

SERVICING SPECIFICATIONS

[1] ENGINE BODY

CYLINDER HEAD

Item		Factory Specification	Allowable Limit
Cylinder Head Surface	Flatness	—	0.05 mm 0.0019 in.
Top Clearance	Thickness	0.6 to 0.8 mm 0.0237 to 0.0315 in.	—
Cylinder Head Gasket Shim		0.2 mm 0.0079 in.	—
Cylinder Head Gasket	Thickness	Free 1.15 to 1.30 mm 0.0453 to 0.0512 in.	—
		Tightened 1.05 to 1.15 mm 0.0413 to 0.0453 in.	—
Compression Pressure		3.09 MPa 31.5 kgf/cm ² 448 psi	2.32 MPa 23.7 kgf/cm ² 337 psi

VALVES

Valve Clearance (Cold)	Thickness	D850-5B, D950-5B	0.145 to 0.185 mm 0.0057 to 0.0073 in.	—
		V1200-5B	0.145 to 0.185 mm 0.0057 to 0.0073 in.	—
Valve Seat	Width		IN. 2.12 mm 0.0835 in.	—
	Angle		EX. 2.12 mm 0.0835 in. IN. 0.785 rad. 45° EX. 0.785 rad. 45°	— — — —
Valve Face	Angle		IN. 0.794 rad. 45.5° EX. 0.794 rad. 45.5°	— —
Valve Recessing			0.9 to 1.1 mm 0.036 to 0.043 in.	1.3 mm 0.051 in.
Valve Stem to Valve Guide	Clearance		0.035 to 0.065 mm 0.0014 to 0.0025 in.	0.1 mm 0.0039 in.
Valve Stem	O.D.		6.960 to 6.975 mm 0.2741 to 0.2746 in.	—
Valve Guide	I.D.		7.010 to 7.025 mm 0.2760 to 0.2765 in.	—

VALVE TIMING

Item		Factory Specification	Allowable Limit
Inlet Valve	Open	0.35 rad., 20° before T.D.C.	—
	Close	0.79 rad., 45° after B.D.C.	—
Exhaust Valve	Open	0.87 rad., 50° before B.D.C.	—
	Close	0.26 rad., 15° after T.D.C.	—

VALVE SPRING

Free Length		35.1 to 35.6 mm 1.382 to 1.401 in.	34.8 mm 1.370 in.
Setting Load / Setting Length		73.5 N/31.0 mm 7.5 kgf/31.0 mm 16.5 lbs/1.22 in.	62.8 N/31.0 mm 6.4 kgf/31.0 mm 14.1 lbs/1.22 in.
Tilt		—	1.3 mm 0.051 in.

ROCKER ARM

Rocker Arm Shaft to Rocker Arm	Clearance	0.016 to 0.068 mm 0.0007 to 0.0026 in.	0.12 mm 0.0047 in.
Rocker Arm Shaft	O.D.	10.973 to 10.984 mm 0.4321 to 0.4324 in.	—
Rocker Arm	I.D.	11.000 to 11.041 mm 0.4331 to 0.4347 in.	—

TAPPET

Tappet to Guide	Clearance	0.020 to 0.062 mm 0.0008 to 0.0024 in.	0.10 mm 0.0039 in.
Tappet	O.D.	19.959 to 19.980 mm 0.7858 to 0.7866 in.	—
Tappet Guide	I.D.	20.000 to 20.021 mm 0.7874 to 0.7882 in.	—

CAMSHAFT

Item		Factory Specification	Allowable Limit
Camshaft	Side Clearance	0.07 to 0.22 mm 0.0028 to 0.0087 in.	0.3 mm 0.0118 in.
Camshaft	Alignment	—	0.08 mm 0.0031 in.
Cam	Height (IN., EX.)	26.88 mm 1.0583 in.	26.83 mm 1.0563 in.
Camshaft	Oil Clearance	0.050 to 0.091 mm 0.0020 to 0.0035 in.	0.15 mm 0.0059 in.
Camshaft Journal	O.D.	32.934 to 32.950 mm 1.2967 to 1.2972 in.	—
Camshaft Bearing	I.D.	33.000 to 33.025 mm 1.2993 to 1.3002 in.	—

TIMING GEAR

Timing Gear	Backlash	0.042 to 0.115 mm 0.0017 to 0.0045 in.	0.20 mm 0.0079 in.
Idle Gear	Side Clearance	0.20 to 0.51 mm 0.0079 to 0.0201 in.	0.80 mm 0.0315 in.
Idle Gear Shaft to Idle Gear Bushing	Clearance	0.020 to 0.054 mm 0.0008 to 0.0021 in.	0.10 mm 0.0039 in.
Idle Gear Shaft	O.D.	29.967 to 29.980 mm 1.1798 to 1.1803 in.	—
Idle Gear Bushing	I.D.	30.000 to 30.021 mm 1.1811 to 1.1819 in.	—

PISTON AND PISTON RING

Item		Factory Specification	Allowable Limit
Piston Pin-bore	I.D.	20.000 to 20.013 mm 0.7874 to 0.7879 in.	20.03 mm 0.7886 in.
Compression Ring 2 to Ring Groove	Clearance	0.085 to 0.112 mm 0.0034 to 0.0044 in.	0.20 mm 0.0079 in.
Piston Ring Groove	Width	1.555 to 1.570 mm 0.0613 to 0.0618 in.	—
Compression Ring 2	Width	1.458 to 1.470 mm 0.0574 to 0.0578 in.	—
Oil Ring to Ring Groove	Clearance	0.020 to 0.055 mm 0.0008 to 0.0021 in.	0.20 mm 0.0079 in.
Piston Ring Groove	Width	4.010 to 4.030 mm 0.1579 to 0.1586 in.	—
Oil Ring	Width	3.975 to 3.990 mm 0.1565 to 0.1571 in.	—
Piston and Piston Ring	Oversize	+ 0.5 mm + 0.008 in.	—
Compression Ring 1	Ring Gap	D850-5B	0.25 to 0.40 mm 0.0098 to 0.0157 in.
Compression Ring 2	Ring Gap		0.25 to 0.40 mm 0.0098 to 0.0157 in.
Oil Ring	Ring Gap		0.25 to 0.40 mm 0.0098 to 0.0157 in.
Compression Ring 1	Ring Gap	D950-5B V1200-5B	0.20 to 0.35 mm 0.0079 to 0.0138 in.
Compression Ring 2	Ring Gap		0.30 to 0.45 mm (0.0118 to 0.0177 in.)
Oil Ring	Ring Gap		0.25 to 0.40 mm (0.0098 to 0.0157 in.)
Piston and Piston Ring	Oversize	+ 0.5 mm + 0.008 in.	—

CONNECTING ROD

Connecting Rod	Alignment	—	0.05 mm 0.0020 in.
Piston Pin to Small End Bushing	Clearance	0.014 to 0.038 mm 0.0006 to 0.0015 in.	0.15 mm 0.0059 in.
Piston Pin	O.D.	20.002 to 20.011 mm 0.7875 to 0.7878 in.	—
Small End Bushing	I.D.	20.025 to 20.040 mm 0.7884 to 0.7889 in.	—
(Service Parts Dimension) Piston Pin to Small End Bushing	Clearance	0.015 to 0.075 mm 0.0006 to 0.0029 in.	0.15 mm 0.0059 in.
Piston Pin	O.D.	20.002 to 20.011 mm 0.7875 to 0.7878 in.	—
Small End Bushing	I.D.	20.026 to 20.077 mm 0.7885 to 0.7904 in.	—

CRANKSHAFT

Item		Factory Specification	Allowable Limit
Crankshaft	Alignment	0.02 mm 0.0008 in.	0.08 mm 0.0031 in.
Crankshaft to Crankshaft Bearing 1	Oil Clearance	0.034 to 0.106 mm 0.0014 to 0.0041 in.	0.20 mm 0.0079 in.
Crankshaft	O.D.	43.934 to 43.950 mm 1.7297 to 1.7303 in.	—
Crankshaft Bearing 1	I.D.	43.984 to 44.040 mm 1.7317 to 1.7338 in.	—
Crankshaft to Crankshaft Bearing 2	Oil Clearance	0.034 to 0.092 mm 0.0014 to 0.0036 in.	0.20 mm 0.0079 in.
Crankshaft	O.D.	43.934 to 43.950 mm 1.7297 to 1.7303 in.	—
Crankshaft Bearing 2	I.D.	43.984 to 44.026 mm 1.7317 to 1.7333 in.	—
Crank Pin to Crank Pin Bearing	Oil Clearance	0.029 to 0.087 mm 0.0012 to 0.0034 in.	0.20 mm 0.0079 in.
Crank Pin	O.D.	36.959 to 36.975 mm 1.4551 to 1.4557 in.	—
Crank Pin Bearing	I.D.	37.004 to 37.046 mm 1.4569 to 1.4585 in.	—
Crankshaft	Side Clearance	0.15 to 0.31 mm 0.0059 to 0.0122 in.	0.50 mm 0.0197 in.
Crankshaft Sleeve	Wear	—	0.10 mm 0.0039 in.

CYLINDER LINER

Item		Factory Specification	Allowable Limit
Cylinder Liner	I.D.	D850-5B	72.000 to 72.019 mm 2.8347 to 2.8354 in.
		D950-5B V1200-5B	75.000 to 75.019 mm 2.9528 to 2.9535 in.
Cylinder Liner	I.D.	D850-5B	72.500 to 72.519 mm 2.8543 to 2.8551 in.
		D950-5B V1200-5B	75.500 to 75.519 mm 2.9725 to 2.9732 in.

[2] LUBRICATING SYSTEM**OIL PUMP**

Engine Oil Pressure	At Idle Speed		68 kPa 0.7 kgf/cm ² 10 psi	—
	At Rated Speed	D850-5B	245 to 343 kPa 2.5 to 3.5 kgf/cm ² 36 to 49 psi	245 kPa 2.5 kgf/cm ² 36 psi
		D950-5B V1200-5B	167 to 294 kPa 1.7 to 3.0 kgf/cm ² 24 to 43 psi	167 kPa 1.7 kgf/cm ² 24 psi
Inner Rotor to Outer Rotor	Clearance		0.11 to 0.15 mm 0.0043 to 0.0059 in.	0.20 mm 0.0079 in.
Outer Rotor to Pump Body	Clearance		0.07 to 0.15 mm 0.0028 to 0.0059 in.	0.25 mm 0.0098 in.
Inner Rotor to Cover	End Clearance		0.08 to 0.13 mm 0.0031 to 0.0051 in.	—

[3] COOLING SYSTEM**THERMOSTAT**

Thermostat's Valve Temperature	Opening start	80.5 to 83.5°C 176.9 to 182.3°F	—
	Temperature when completely opened	95°C 203°F	—

RADIATOR

Radiator	Water Tightness	Water tightness at specified pressure 137 kPa, 1.4 kgf/cm ² 20 psi	—
Radiator Cap	Opening Pressure	10 seconds or more 88 → 59 kPa 0.9 → 0.6 kgf/cm ² 13 → 9 psi	—
Fan Belt Tension	Deflection	10 mm / 98N, 10 kgf 0.4 in. / 22 lbs	—

[4] FUEL SYSTEM**INJECTION PUMP**

Item		Factory Specification	Allowable Limit
Injection Order	D850-5B, D950-5B V1200-5B	1-2-3 1-3-4-2	—
Injection Timing	D850-5B D950-5B	0.349 to 0.384 rad. 20° to 22° before T.D.C.	—
	V1200-5B	0.366 to 0.402 rad. 21° to 23° before T.D.C.	—
Pump Element	Fuel Tightness	60 seconds or more 39.23 MPa → 34.32 MPa 400 kgf/cm ² → 350 kgf/cm ² 5689 psi → 4978 psi	30 seconds 39.23 MPa → 34.32 MPa 400 kgf/cm ² → 350 kgf/cm ² 5689 psi → 4978 psi
Delivery Valve	Fuel Tightness	10 seconds or more 21.57 MPa → 20.59 MPa 220 kgf/cm ² → 210 kgf/cm ² 3129 psi → 2987 psi	5 seconds 21.57 MPa → 20.59 MPa 220 kgf/cm ² → 210 kgf/cm ² 3129 psi → 2987 psi

INJECTION NOZZLE

Injection Nozzle	Fuel Injection Pressure	13.73 to 14.71 MPa 140 to 150 kgf/cm ² 1991 to 2133 psi	—
Nozzle Valve Seat	Fuel Tightness	When the pressure is 12.75 MPa (130 kgf/cm ² , 1849 psi), the valve seat must be fuel tightness.	—

TIGHTENING TORQUES

Screws, bolts and nuts must be tightened to the specified torque using a torque wrench. Several screws, bolts and nuts such as those used on the cylinder head must be tightened in proper sequence and at the proper torque.

(For general use screws and nuts : See page S.G-4)

■ NOTE

- For " * " marked screws, bolts and nuts on the table, apply engine oil to their threads and seats before tightening.
- The letter "M" in Size x Pitch means that the screw, bolt or nut dimension stands for metric. The "Size" is the nominal outside diameter in mm of the threads. The "Pitch" is the nominal distance in mm between two threads.

Item	Size x Pitch	N·m	kgf·m	ft-lbs
* Cylinder head cover cap nuts	M7 x 1.0	6.9 to 8.8	0.7 to 0.9	5.1 to 6.5
* Cylinder head screws and nuts	M9 x 1.25	64.7 to 69.6	6.6 to 7.1	47.7 to 51.4
* Bearing case screws 1	M7 x 1.0	26.5 to 30.4	2.7 to 3.1	19.5 to 22.4
* Bearing case screws 2	M8 x 1.25	29.4 to 34.3	3.0 to 3.5	21.7 to 25.3
* Flywheel screws	M10 x 1.25	53.9 to 58.8	5.5 to 6.0	39.8 to 43.4
* Connecting rod screws	M7 x 0.75	26.5 to 30.4	2.7 to 3.1	19.5 to 22.4
* Rocker arm bracket nuts	M7 x 1.0	16.7 to 20.6	1.7 to 2.1	12.3 to 15.2
* Idle gear shaft screws	M6 x 1.0	9.8 to 11.3	1.00 to 1.15	7.2 to 8.3
* Crankshaft nut	M20 x 1.5	137.3 to 156.9	14.0 to 16.0	101.3 to 115.7
Glow plugs	M10 x 1.25	19.6 to 24.5	2.0 to 2.5	14.5 to 18.1
Drain plug	M12 x 1.25	39.2 to 49.0	4.0 to 5.0	28.9 to 36.2
Nozzle holder assembly	M24 x 2.0	39.2 to 49.0	4.0 to 5.0	28.9 to 36.2
Nozzle holder body to nozzle nut		58.8 to 78.4	6.0 to 8.0	43.4 to 57.8
Oil switch taper screw	PT 1/8	14.7 to 19.6	1.5 to 2.0	10.8 to 14.5
Fuel limit lock nut	M12 x 1.0	27.5 to 34.3	2.8 to 3.5	20.3 to 25.3
Fuel limit cap nut	M12 x 1.0	24.5 to 29.4	2.5 to 3.0	18.1 to 21.7
Injection pipe retaining nuts	M12 x 1.5	14.7 to 24.5	1.5 to 2.5	10.8 to 18.1

CHECKING, DISASSEMBLING AND SERVICING

[1] ENGINE BODY

CHECKING AND ADJUSTING

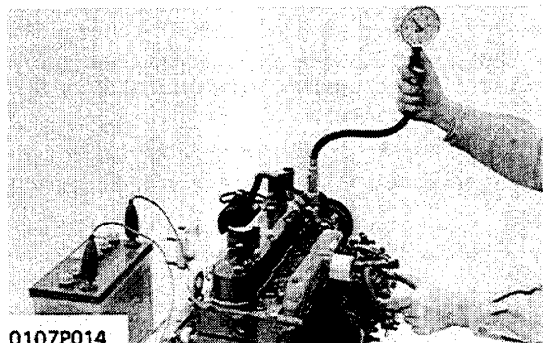

0107P014

Compression Pressure

1. Warm up the engine and stop it.
2. Remove the air cleaner and the muffler.
3. Remove the nozzle holders from all the cylinders. (See page S.1-14)
4. Set a compression tester (Code No. 07909-30203) to the nozzle holder hole.
5. Cut the fuel (pull the stop lever), and run the engine for 5 to 10 seconds (at 200 to 300 rpm) and read the maximum pressure.
Execute the test at least twice.
6. If the compression pressure is less than the allowable limit, pour a small amount of engine oil through the nozzle holder hole and test again.
7. If the compression pressure reaches to the allowable limit, check the cylinder liner and the piston rings.
If not, check the top clearance, valve and cylinder head.

NOTE

- For the test, use a fully charged battery and the specified valve clearance.
- Variances in cylinder compression values should be under 10%.

Compression pressure	Factory spec.	3.09 MPa 31.5 kgf/cm ² 448 psi
	Allowable limit	2.32 MPa 23.7 kgf/cm ² 337 psi

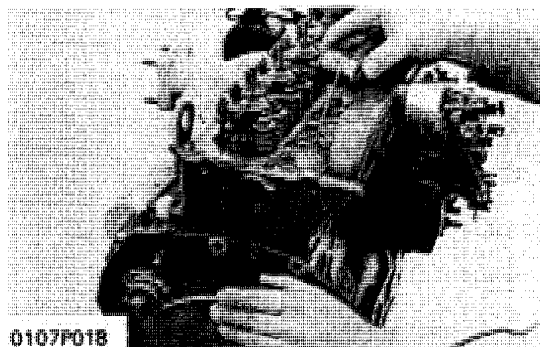

0107F018

Top Clearance

1. Tighten the cylinder head screws with the specified torque (64.7 to 69.6 N·m, 6.6 to 7.1 kgf·m, 47.7 to 51.4 ft-lbs).
2. Remove the nozzle holder. (See page S.1-14)
3. Lower the piston in the cylinder.
4. Insert a high quality fuse from the nozzle holder hole.
Be careful not to let the fuse touch the valve head.
5. Rotate the flywheel with your hand.
6. Take the fuse out carefully, and measure the place where the fuse was crushed with vernier calipers.
7. If the clearance is less than the factory specification, adjust by inserting a shim (1) between the cylinder head and gasket.
If it exceeds the factory specification, remove the shim.
In case of the engine without shim, check the oil clearance at crank pin, crank journal and piston pin.

(Reference)

- Thickness of cylinder head gasket shim:
0.2 mm (0.0079 in.)

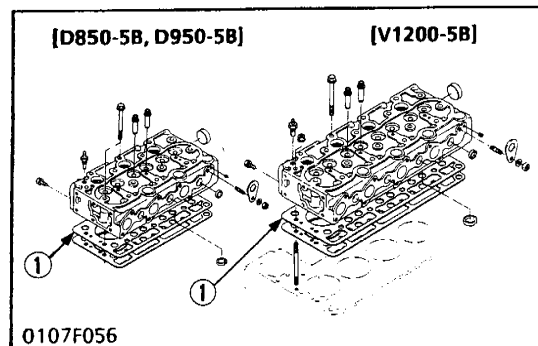

0107F056

(1) Shim

Top clearance	Factory spec.	0.6 to 0.8 mm 0.0237 to 0.0315 in.
---------------	---------------	---------------------------------------

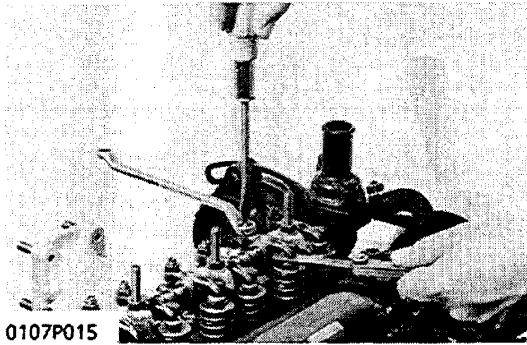

0107P015

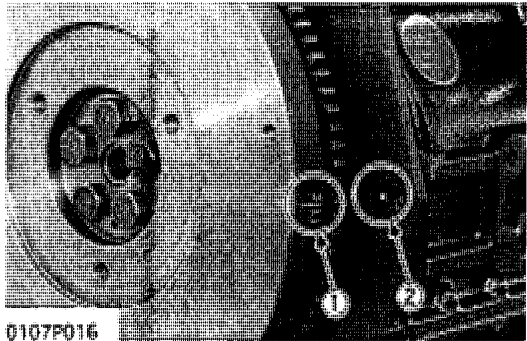

0107P016

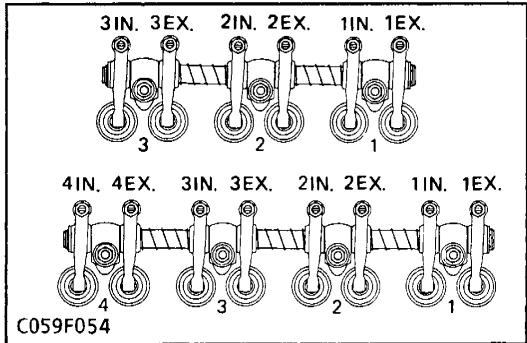

C059F054

(1) TC Mark

(2) Timing Plate

Valve Clearance

1. Remove the cylinder head cover.
2. Turn the flywheel until No. 1 cylinder is at T.D.C. of its compression stroke and align the 1TC mark or 1.4TC mark on the flywheel with the timing plate.
3. Measure the clearance at the valves marked with o in the table below with a feeler gauge.
4. If the clearance is not within the factory spec, turn the adjusting screw to adjust.
5. Turn the flywheel just one turn to position the No. 1 cylinder valves at the T.D.C. during overlap.
6. Measure the clearance at the valves marked ● in the table below with a feeler gauge.
7. If the clearance is not within the factory spec., adjust.

Valve clearance IN and EX. (When cold)	Factory spec.	0.145 to 0.185 mm 0.0057 to 0.0073 in
--	---------------	--

[D850-5B-D950-5B]

- Firing order 1→2→3

Cylinder No.	1		2		3	
Valve	IN.	EX.	IN.	EX.	IN.	EX.
Checking	o	o	●	o	o	●

[V1200-5B]

- Firing order 1→3→4→2

Cylinder No.	1		2		3		4	
Valve	IN.	EX.	IN.	EX.	IN.	EX.	IN.	EX.
Checking	o	o	o	●	●	o	●	●

DISASSEMBLING AND ASSEMBLING

(1) Cylinder Head

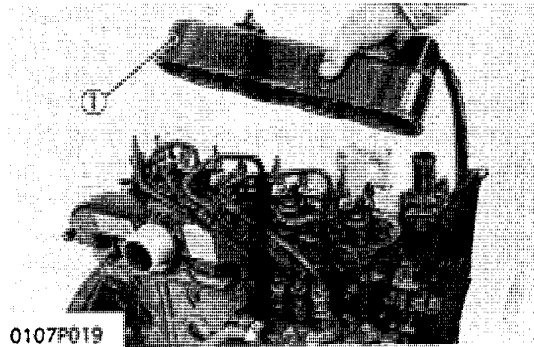

0107P019

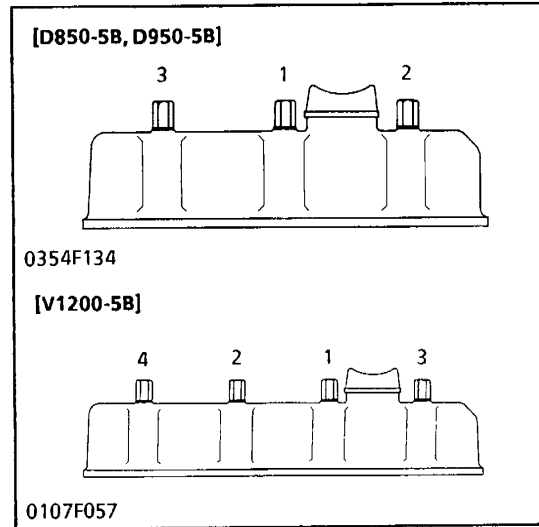

Cylinder Head Cover

1. Remove the cylinder head cover cap nuts.
2. Remove the cylinder head cover (1).

(When reassembling)

- Check to see that the cylinder head cover gasket is not defective.
- Tighten the cylinder head cover cap nuts in the order as shown in figure.

Tightening torque	Cylinder head cover cap nut	6.9 to 8.8 N·m 0.7 to 0.9 kgf·m 5.1 to 6.5 ft·lbs
-------------------	-----------------------------	---

(1) Cylinder Head Cover

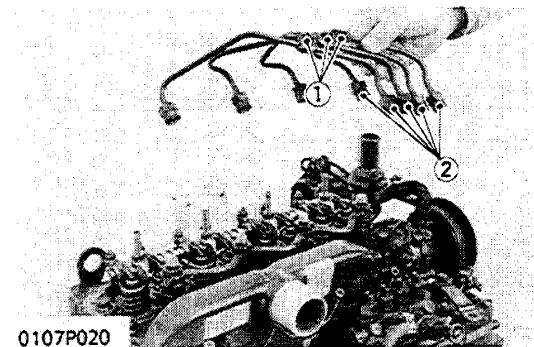

0107P020

Injection Pipes

1. Loosen the pipe clamps (1).
2. Remove the injection pipes (2).

(When reassembling)

Tightening torque	Injection pipe retaining nut	14.7 to 24.5 N·m 1.5 to 2.5 kgf·m 10.8 to 18.1 ft·lbs
-------------------	------------------------------	---

(1) Pipe Clamps

(2) Injection Pipes

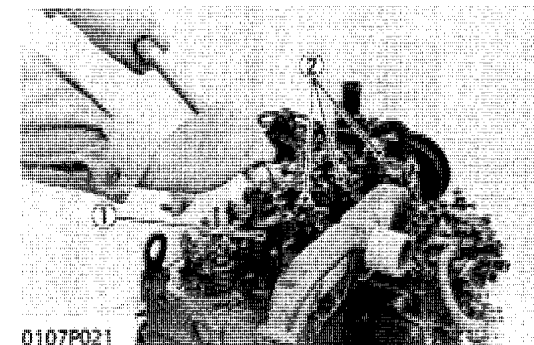

0107P021

Nozzle Holder Assembly

1. Remove the fuel overflow pipes.
2. Loosen the lock nuts, and remove the nozzle holder assemblies with a nozzle holder socket wrench 27 (1) (Code No. 07916-30841).
3. Remove the copper gaskets on the seats.

(When reassembling)

Tightening torque	Nozzle holder	39.2 to 49.0 N·m 4.0 to 5.0 kgf·m 28.9 to 36.2 ft·lbs
-------------------	---------------	---

(1) Nozzle Holder Socket Wrench 27

(2) Nozzle Holder Assembly

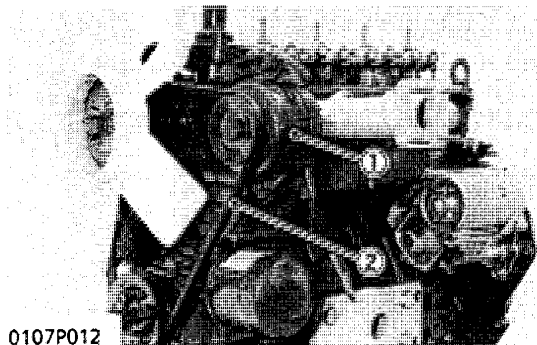

0107P012

AC Dynamo and Fan Belt

1. Remove the AC dynamo (1).
2. Remove the fan belt (2).

(When reassembling)

- Check to see that there are no cracks on the belt surface.

■ IMPORTANT

- After reassembling the fan belt, be sure to adjust the fan belt tension. (See page S.G-7)

(1) AC Dynamo

(2) Fan Belt

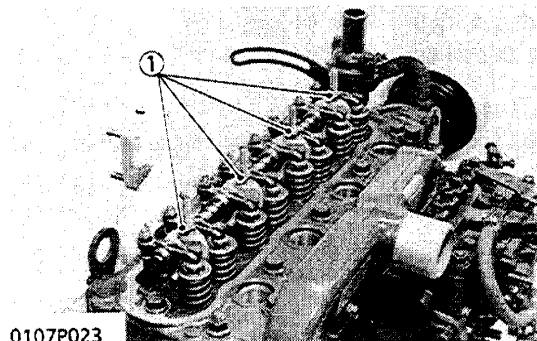

0107P023

Rocker Arm

1. Remove the rocker arm bracket mounting nuts (1).
2. Remove the rocker arm as a unit.

(When reassembling)

Tightening torque	Rocker arm bracket mounting nut	16.7 to 20.6 N·m 1.7 to 2.1 kgf·m 12.3 to 15.2 ft-lbs
-------------------	---------------------------------	---

■ IMPORTANT

- After reassembling the rocker arm, be sure to adjust the valve clearance. (See page S.1-13)

(1) Rocker Arm Bracket Mounting Nuts

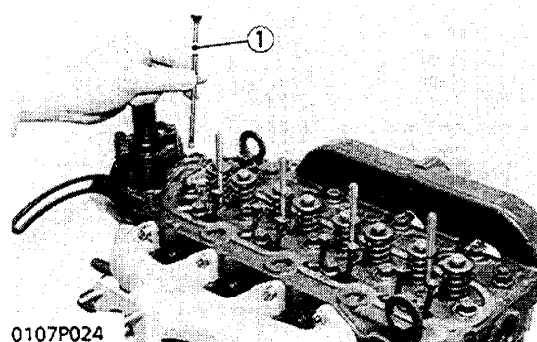

0107P024

Push Rod

1. Remove the push rods (1).

(When reassembling)

- When putting the push rods (1) onto the tappets, check to see if their ends are properly engaged with the grooves.

(1) Push Rod

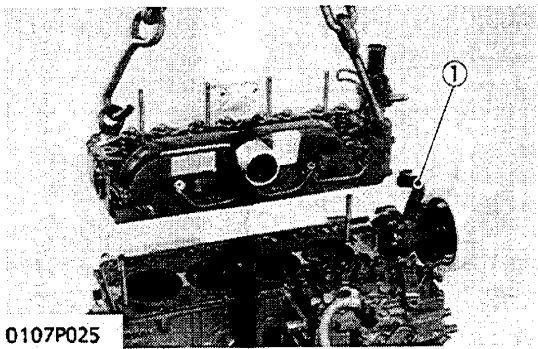

0107P025

Cylinder Head

1. Loosen the pipe band, and remove the water return pipe 2 (1).
2. Remove the cylinder head screws and remove the cylinder head.
3. Remove the cylinder head gasket and O-ring.

(When reassembling)

- Replace the head gasket with a new one.
- Install the cylinder head, using care not to damage the O-ring.
- Tighten the cylinder head screws gradually in the order as shown in figure after applying engine oil.
- Retighten the cylinder head screws after running the engine for 30 minutes.

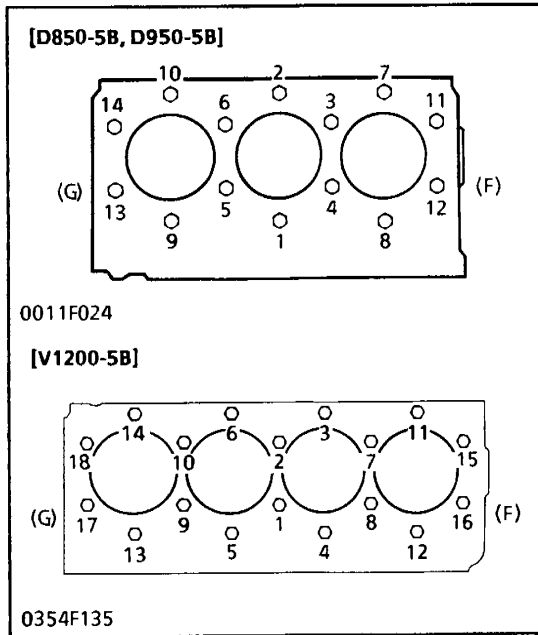

0011F024

Tightening torque	Cylinder head screw and nut	64.7 to 69.6 N·m 6.6 to 7.1 kgf·m 47.7 to 51.4 ft-lbs
-------------------	-----------------------------	---

(1) Water Return Pipe 2

(G) Gear Case Side

(F) Flywheel Side

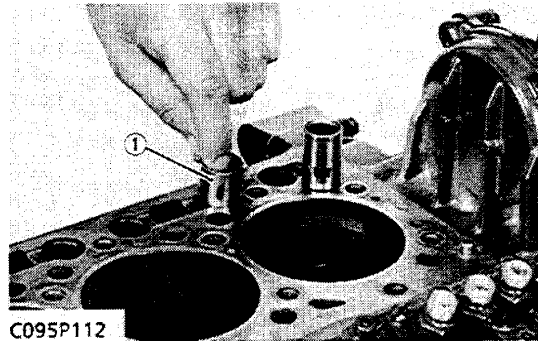

C095P112

Tappets

1. Remove the tappets from the crankcase.

(When reassembling)

- Before installing the tappets, apply engine oil thinly around them.

(1) Tappet

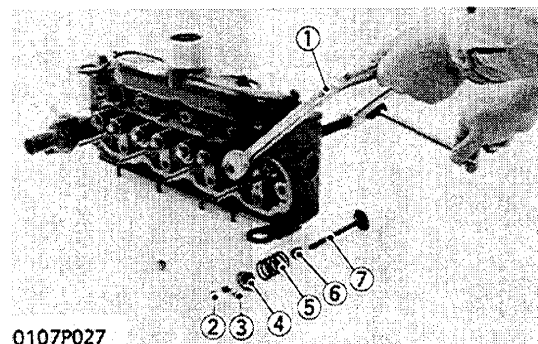

0107P027

Valves

1. Remove the valve cap (2).
2. Remove the valve spring collet (3), pushing the valve spring retainer (4) by valve spring replacer (1).
3. Remove the valve spring retainer (4), valve spring (5) and valve stem seal (6).
4. Remove the valve (7).

■ IMPORTANT

- **Never change the combination of valves and valve guides. When a valve is to be used again, it should be suitably identified to ensure it is replaced in its original position.**

(1) Valve Spring Replacer

(5) Valve Spring

(2) Valve Cap

(6) Valve Stem Seal

(3) Valve Spring Collet

(7) Valve

(4) Valve Spring Retainer

(2) Gear Case**Fuel Lift Pump**

1. Loosen the pipe clamp and remove the fuel pipe from the injection pump side.
2. Remove the fuel lift pump mounting nuts.
3. Remove the fuel lift pump (1).

(When reassembling)

- Apply a liquid gasket (Three Bond 1215 or equivalent) to the both sides of fuel lift pump gasket.

(1) Fuel Lift Pump

Hydraulic Pump

See page S.8-6, 7.

Injection Pump Cover

1. Remove the injection pump cover (1).

(When reassembling)

- Apply a liquid gasket (Three Bond 1215 or equivalent) to the both sides of injection pump cover gasket.

(1) Injection Pump Cover

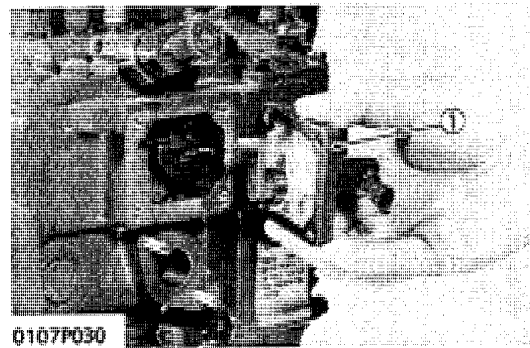
**Injection Pump**

1. Remove the injection pump mounting screws and nuts.
2. Align the control rack pin (3) with the groove (1) on the crankcase, and remove the injection pump (4).
3. Remove the injection pump shims.

(When reassembling)

- When installing the injection pump, insert the control rack pin (3) firmly into the groove (2) of the fork lever 1.
- Addition or reduction of one shim delays or advances the injection timing by 0.0262 rad. (1.5°).

(Reference)

- Thickness of injection pump shim:
0.15 mm (0.006 in.)

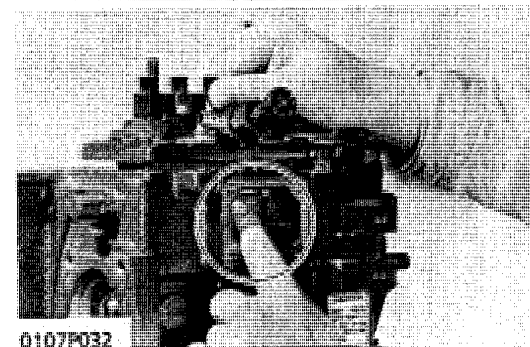
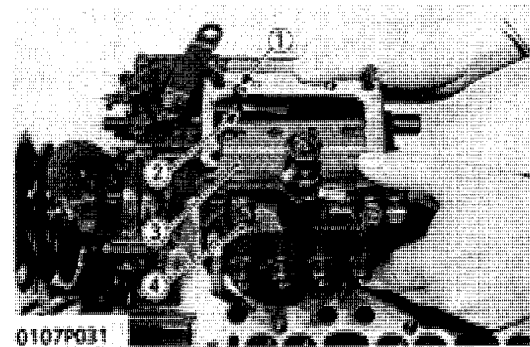
(1) Groove
(2) Groove(3) Control Rack Pin
(4) Injection Pump

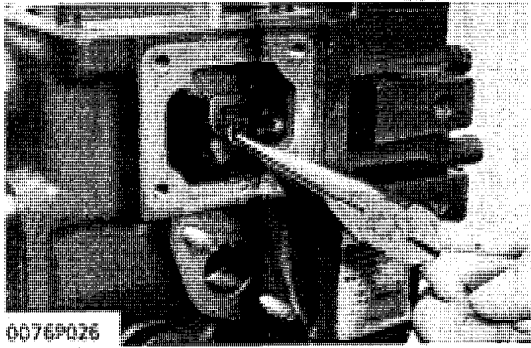

0076P026

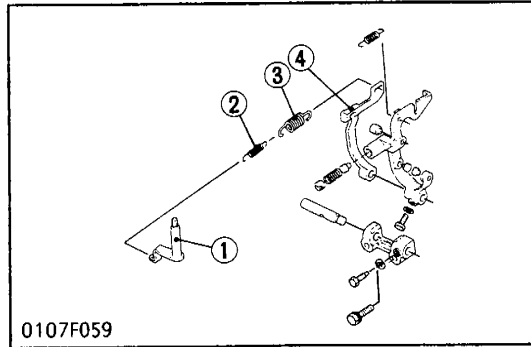

0107F059

Governor Spring

1. Remove the governor springs 1 (3) and 2 (2) from the fork lever 2 (4).

(When reassembling)

- Fix the governor springs 1 (3) and 2 (2) to the governor lever 1 (1), and pull the springs through the window of the injection pump, and springs will be able to be hooked on to the governor fork lever 2 (4) with ease.

- (1) Governor Lever
(2) Governor Spring 2

- (3) Governor Spring 1
(4) Fork Lever 2

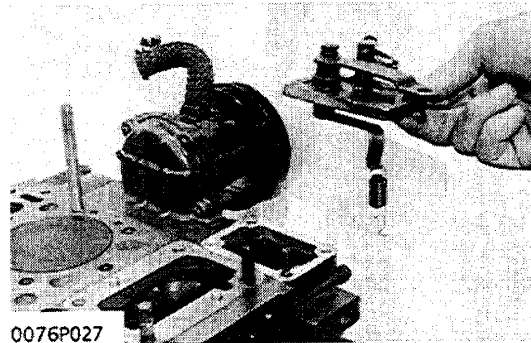

0076P027

Speed Control Plate

1. Remove the speed control plate with the governor springs 1 and 2.

(When reassembling)

- Be careful not to drop the governor springs 1 and 2 in the gear case.
- Apply a liquid gasket (Three Bond 1215 or equivalent) to both sides of the speed control plate gasket.

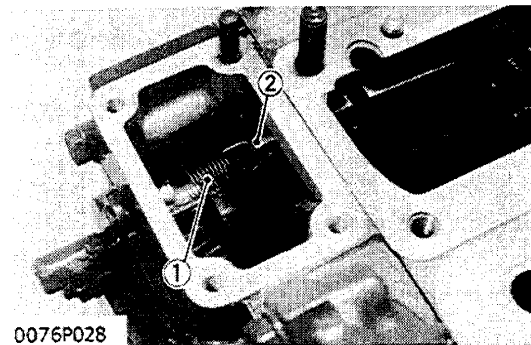

0076P028

Start Spring

1. Remove the start spring (1) from the fork lever 1 (2).

(When reassembling)

- Be careful not to drop the start spring (1) in the gear case.

- (1) Start Spring

- (2) Fork Lever 1

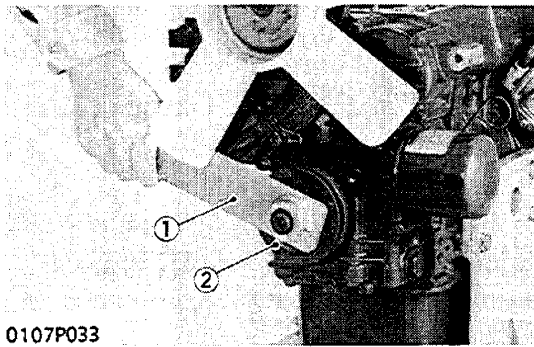

0107P033

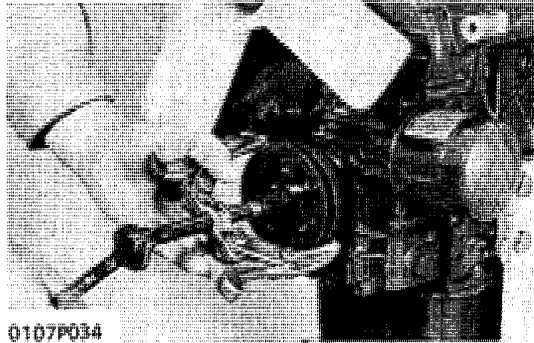

0107P034

Fan Drive Pulley

1. Use the flywheel stopper (See page S.G-29) not to turn the crankshaft. (Refer to page S.1-26).
2. Flatten the crankshaft washer and remove the crankshaft nut with a socket wrench **29** (1) (Code No. **07916-31841**).
3. Pull out the fan drive pulley (2) with a puller.
4. Remove the feather key.

(When reassembling)

- Replace the crankshaft washer with a new one.
- After tightening the crankshaft nut to the specified torque, lock the nut with the crankshaft washer.

Tightening torque	Crankshaft nut	137.3 to 156.9 N·m 14.0 to 16.0 kgf·m 101.3 to 115.7 ft-lbs
-------------------	----------------	---

(1) Socket Wrench **29**

(2) Fan Drive Pulley

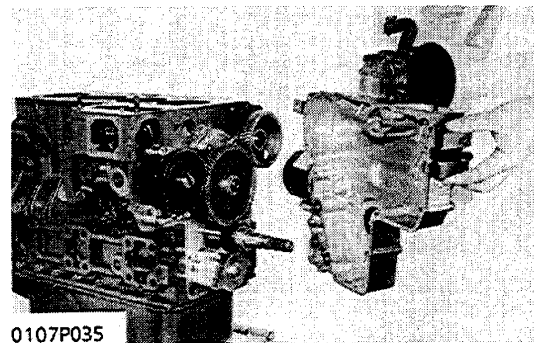

0107P035

Gear Case

1. Remove the gear case.

(When reassembling)

- Apply a liquid gasket (Three Bond 1215 or equivalent) to both sides of the gear case gasket.
- Grease thinly to the oil seal, and install it, ensuring the lip does not come off.
- Be careful not to damage the O-rings.

(3) Camshaft and Fuel Camshaft

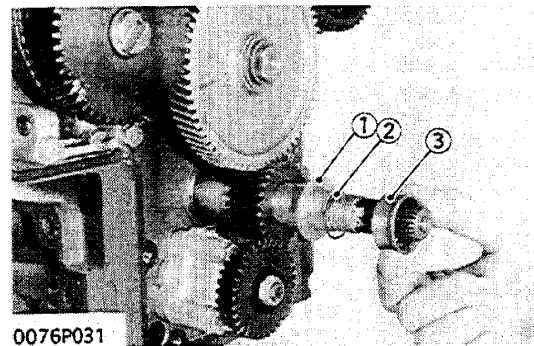

0076P031

Crankshaft Oil Slinger

1. Remove the crankshaft collar (3).
2. Remove the O-ring (2).
3. Remove the crankshaft oil slinger (1).

(When reassembling)

- Be careful not to damage the O-ring.

(1) Crankshaft Oil Slinger
(2) O-ring

(3) Crankshaft Collar

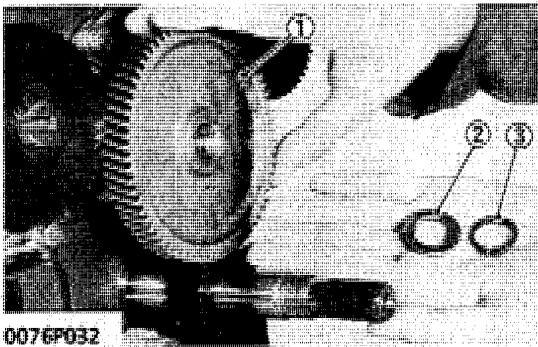

0076P032

Idle Gear

1. Remove the external snap ring (3).
2. Remove the idle collar 2 (2) and idle gear (1).
3. Remove the idle gear collar 1.

(When reassembling)

Tightening torque	Idle gear shaft mounting screw	9.8 to 11.3 N·m 1.00 to 1.15 kgf·m 7.2 to 8.3 ft·lbs
-------------------	--------------------------------	--

■ IMPORTANT

- When installing the idle gear, be sure to align the alignment marks on gears.

Idle gear and crank gear (Alignment mark ".")

Idle gear and camshaft gear (Alignment mark "..")

Idle gear and injection pump gear (Alignment mark ".:")

- (1) Idle Gear (3) External Snap Ring
(2) Idle Collar 2

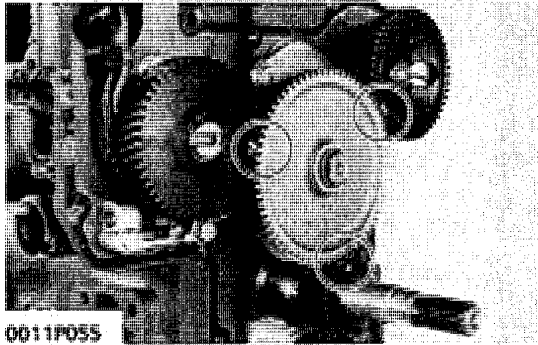

0011P055

Camshaft Stopper Mounting Screw

1. Align the round hole of the cam gear with the camshaft stopper mounting screw position.
2. Remove the camshaft stopper mounting screws.

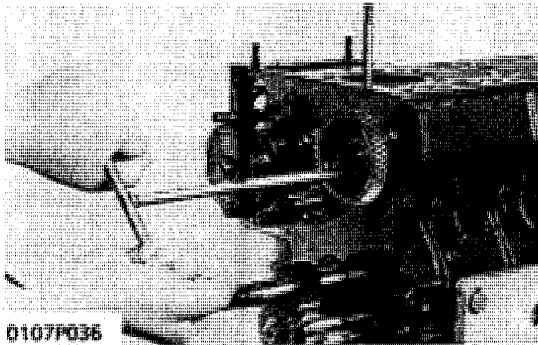

0107P036

Cam Gear and Camshaft

1. Remove the cam gear (1) and camshaft (2).

(When reassembling)

- Apply engine oil thinly to the camshaft before installation.

- (1) Cam Gear (2) Camshaft

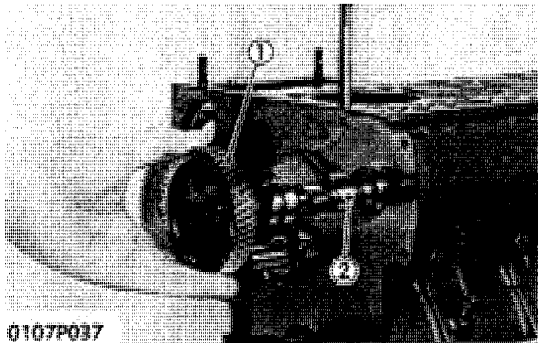

0107P037

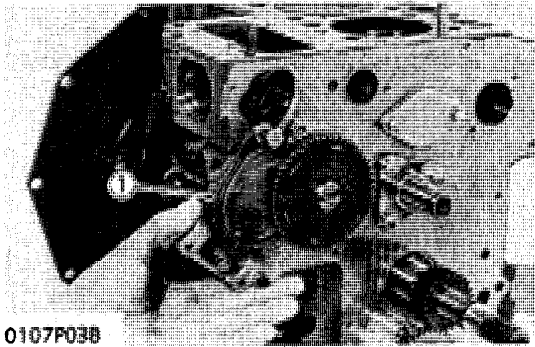

0107P038

Fork Lever Assembly

1. Remove the fork lever holder mounting screws.
2. Remove the fork lever assembly (1).

(1) Fork Lever Assembly

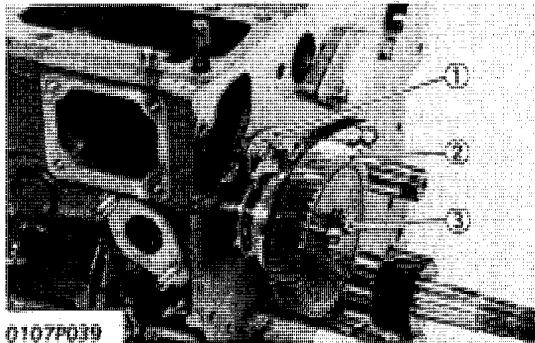

0107P039

Fuel Camshaft

1. Remove the fuel camshaft stopper (1).
2. Remove the fuel camshaft (3) and injection pump gear (2).

(When reassembling)

- Apply engine oil thinly to the fuel camshaft before installation.

(1) Fuel Camshaft Stopper

(3) Fuel Camshaft

(2) Injection Pump Gear

(4) Piston and Connecting Rod

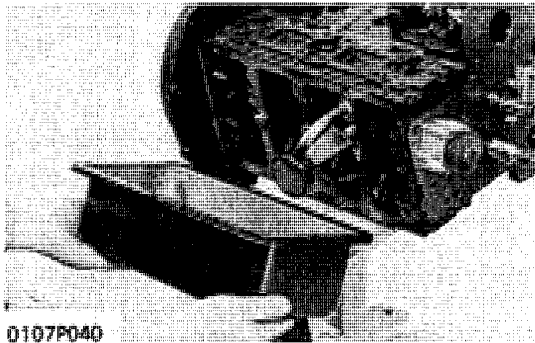

0107P040

Oil Pan

1. Remove the oil pan mounting screws.
2. Remove the oil pan by lightly tapping the rim of the oil pan with a wooden hammer.

(When reassembling)

- Apply a liquid gasket (Three Bond 1215 or equivalent) to both sides of the oil pan gasket.
- To avoid uneven tightening, tighten mounting screws in diagonal order from the center.

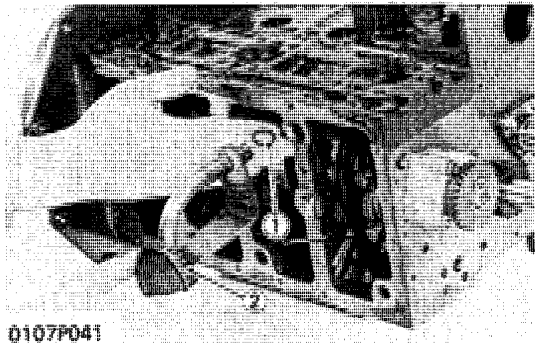

0107P041

Oil Strainer

1. Remove the oil strainer mounting screw.
2. Remove the oil strainer (2).

(When reassembling)

- After cleaning the oil strainer, install it.
- Install the oil strainer, using care not to damage the O-ring (1).

(1) O-ring

(2) Oil Strainer

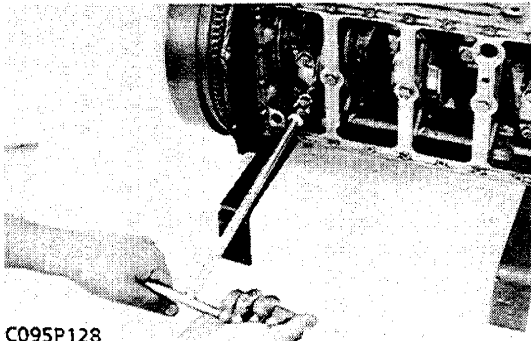

C095P128

Connecting Rod Cap

1. Remove the connecting rod screws from connecting rod cap.
2. Remove the connecting rod caps.

(When reassembling)

- Apply engine oil to the crank pin bearings.
- Apply engine oil to the connecting rod screws.
- Align the marks (1) on the connecting rod and connecting rod cap.

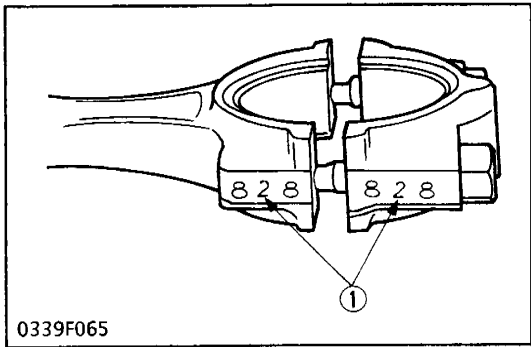

0339F065

Tightening torque	Connecting rod screw	26.5 to 30.4 N·m 2.7 to 3.1 kgf·m 19.5 to 22.4 ft-lbs
-------------------	----------------------	---

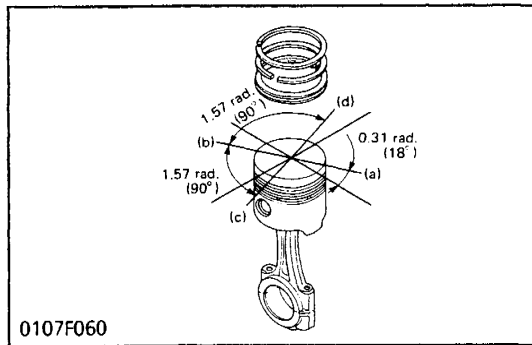
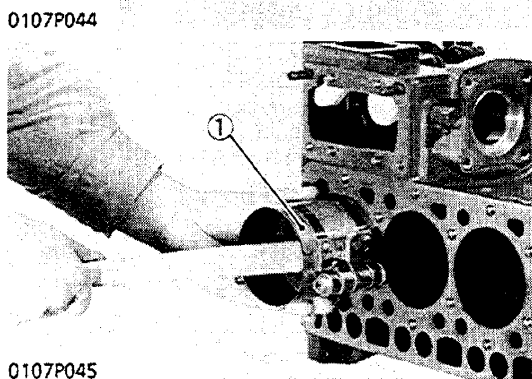
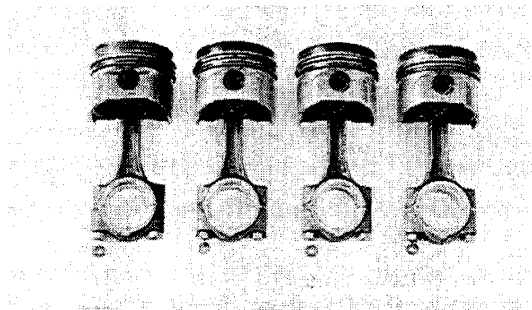
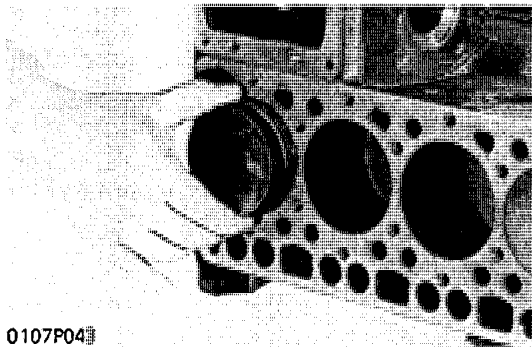

Piston

1. Turn the flywheel, and bring the pistons to the top dead center.
2. Pull out the piston upward by lightly tapping it from the bottom of the crankcase with the grip of a hammer.

(When reassembling)

- Before inserting the piston into the cylinder, apply enough engine oil to the cylinder.
- When inserting the piston into the cylinder, face the mark on the connecting rod to the injection pump.

■ IMPORTANT

- Do not change the combination of cylinder and piston. Make sure of the position of each piston by marking. For example, mark "1" on the No. 1 piston.
- When inserting the piston into the cylinder, place the gap of the compression ring 1 on the opposite side of the combustion chamber and stagger the gaps of the compression ring 2 and oil ring making a right angle from the gap of the compression ring 1.
- Carefully insert the pistons using a piston ring compressor (1) (Code No. 07909-32111). Otherwise, their chrome-plated section may be scratched, causing trouble inside the liner.

(1) Piston Ring Compressor

(a) Combustion Chamber Side
 (b) Gap of Compression Ring 1

(c) Gap of Compression Ring 2
 (d) Gap of Oil Ring

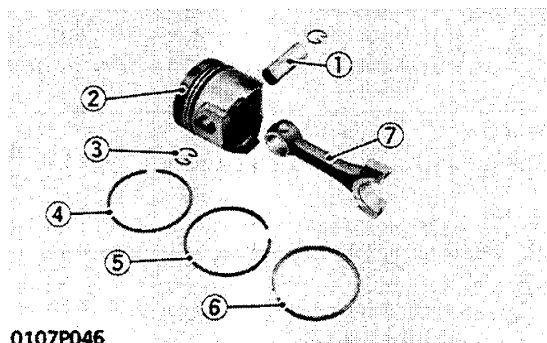

0107P046

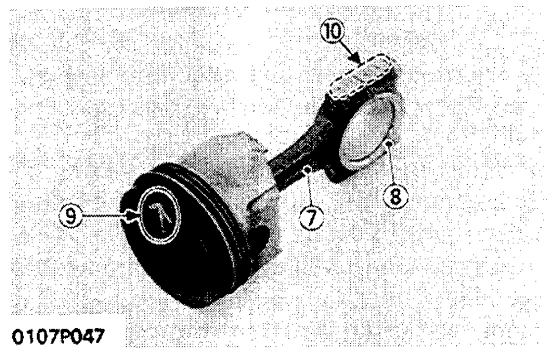

0107P047

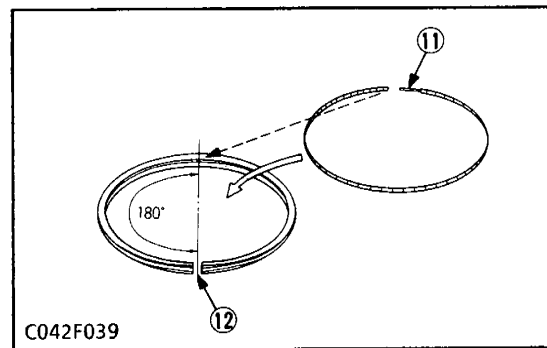

C042F039

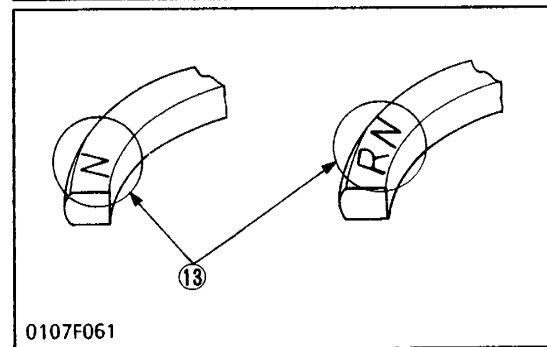

0107F061

Piston Ring and Connecting Rod

1. Remove the piston rings using a piston ring tool (Code No. 07909-32121).
2. Put the parting mark (for example, ↑) (9) on the piston head as shown in photograph.
3. Remove the piston pin (1), and separate the connecting rod (7) from the piston (2).

(When reassembling)

- When installing the rings, assemble the rings so that the manufacturer's mark (13) near the gap faces the top of the piston.
- When installing the oil ring onto the piston, place the expander joint (11) on the opposite side of the oil ring gap (12).
- Apply engine oil to the piston pin.
- When installing the piston pin, immerse the piston in 80° C (176° F) oil for 10 to 15 minutes and insert the piston pin to the piston.
- When installing the connecting rod to the piston, align the mark (10) on the connecting rod to the parting mark (9).

■ IMPORTANT

- Mark the same number on the connecting rod and the piston so as not to change the combination.

- | | |
|--------------------------|--------------------------|
| (1) Piston Pin | (8) Connecting Rod Cap |
| (2) Piston | (9) Parting Mark |
| (3) Piston Pin Snap Ring | (10) Mark |
| (4) Compression Ring 1 | (11) Expander Joint |
| (5) Compression Ring 2 | (12) Oil Ring Gap |
| (6) Oil Ring | (13) Manufacturer's Mark |
| (7) Connecting Rod | |

(5) Starter, Flywheel and Crankshaft

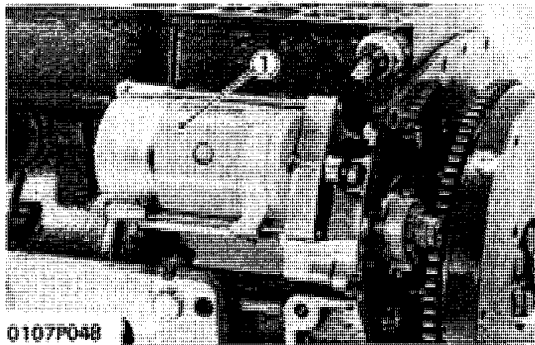

Q107P048

Starter

1. Remove the starter (1).

(1) Starter

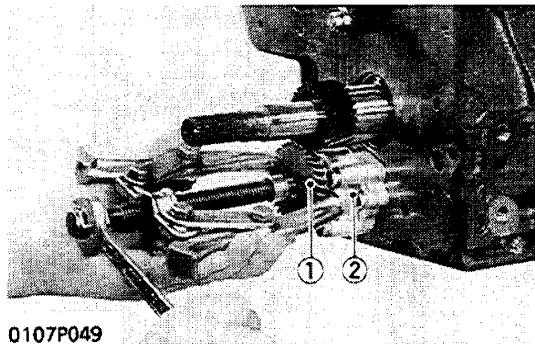

Q107P049

Oil Pump

1. Remove the nut.
2. Pull out the oil pump drive gear (1) with a puller.
3. Remove the oil pump mounting screws.
4. Remove the oil pump (2).

(1) Oil Pump Drive Gear

(2) Oil Pump

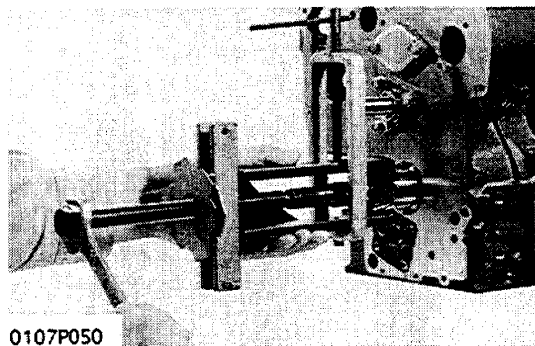

Q107P050

Crank Gear

1. Remove the crank gear with a special-use puller set (Code No. 07916-09032).
2. Remove the feather key on the crankshaft.

(When reassembling)

- Check to see that the feather key is on the crankshaft.
 - Heat the crank gear to approx. 80° C (176° F), and fit on the crankshaft.
- If there is fear of the shaft being damaged, apply more heat to the gear.

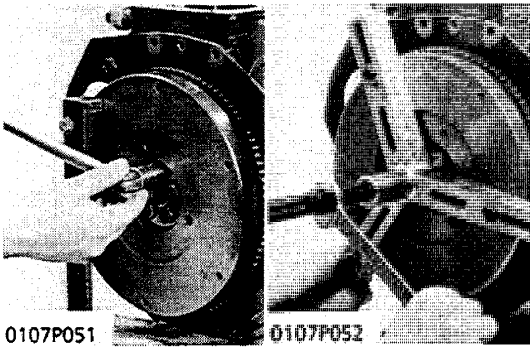

0107P051

0107P052

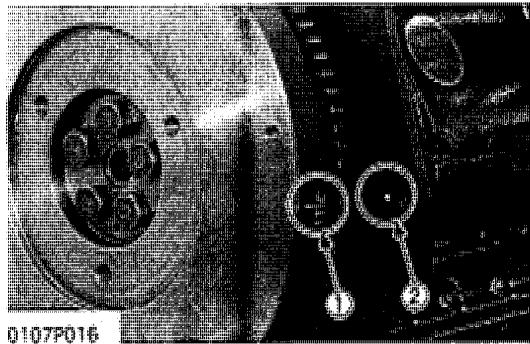

0107P016

Flywheel

1. Lock the flywheel not to turn with the flywheel stopper (See page S.G-28).
2. Remove the flywheel screws, except for two which must be loosened and left as they are.
3. Set a flywheel puller (Code No. 07916-32011), and remove the flywheel.

(When reassembling)

- Apply engine oil to the flywheel screws.
- Put one of the pistons to top dead center, and assemble the flywheel by matching the flywheel's mating mark (1 TC or 1.4TC) (1) to the punch mark (2) of the rear end plate.
- Install the flywheel washer (3) as shown in the figure.

Tightening torque	Flywheel screw	53.9 to 58.8 N·m 5.5 to 6.0 kgf·m 39.8 to 43.4 ft·lbs
-------------------	----------------	---

- (1) Flywheel Mark
- (2) Rear End Plate Mark

- (3) Flywheel Washer
- (4) Mark

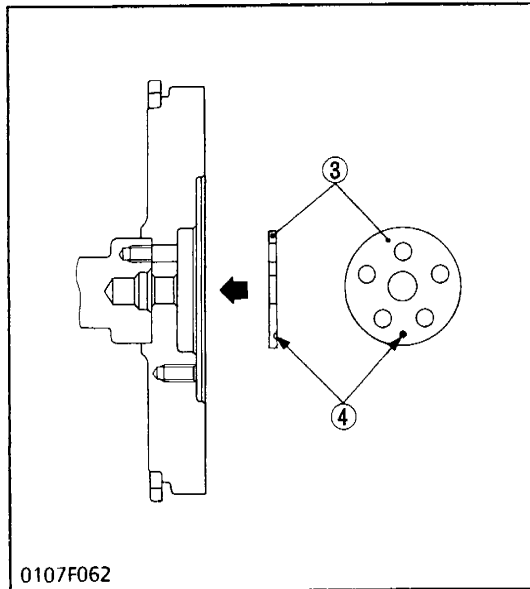

0107F062

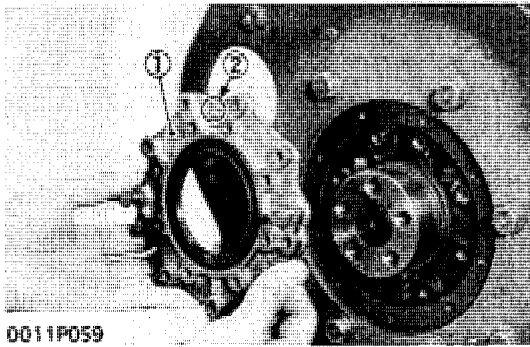

0011P059

(1) Bearing Case Cover (2) Top Mark (上)

Bearing Case Cover

1. Remove the bearing case cover mounting screws.
[First remove the eight screws inside, and then work on the nine screws outside.]
2. Screw the two screws removed above into the right and left holes of the bearing case cover (1), and remove the cover.

(When reassembling)

- When installing the bearing case cover, check to see that there are no scratches on the oil seal lip. Then, apply engine oil, and install.
- When installing the bearing case cover, be sure to check the top mark (上) (2) on the cover.
- Tighten the mounting screws in diagonal order to the specified torque (9.81 to 11.28 N·m, 1.00 to 1.15 kgf·m, 7.23 to 8.32 ft-lbs).

Bearing Case Screw 2

1. Remove the bearing case screws 2.

(When reassembling)

- After mating the holes of bearing case and crankcase, apply engine oil to the screws and tighten them.

Tightening torque	Bearing case screw 2	29.4 to 34.3 N·m 3.0 to 3.5 kgf·m 21.7 to 25.3 ft-lbs
-------------------	-------------------------	---

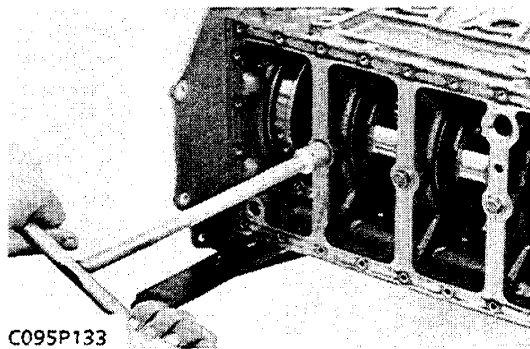

C095P133

Crankshaft

1. Pull out the crankshaft, using care not to damage the crankshaft bearing 1.

(When reassembling)

- Before installing the crankshaft, clean the oil passage in the crankshaft with compressed air.

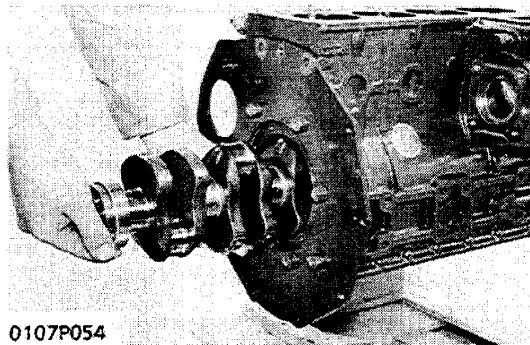

0107P054

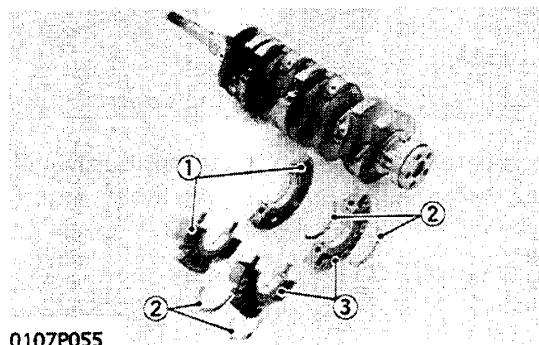

0107P055

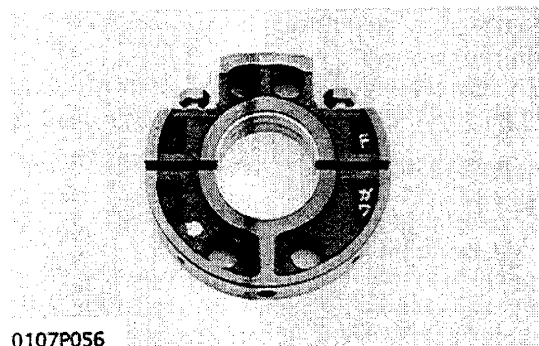

0107P056

Main Bearing Case Assembly

1. Remove the bearing case screws 1, and remove the main bearing case assemblies 1 (3), being careful with the thrust bearing (2) and crankshaft bearing 2.

(When reassembling)

- Clean the oil passage in the main bearing case.
- Apply clean engine oil on the crankshaft bearing 2 and thrust bearings.
- Install the main bearing case assemblies in the original positions. They are not interchangeable.
- When installing the main bearing case assemblies, face the mark (F ガワ) to the flywheel.
- Be sure to install the thrust bearing with its oil groove facing outward.

Tightening torque	Bearing case screw 1	26.5 to 30.4 N·m 2.7 to 3.1 kgf·m 19.5 to 22.4 ft lbs
-------------------	----------------------	---

- (1) Main Bearing Case Assembly 2 (3) Main Bearing Case Assembly 1
(2) Thrust Bearing

SERVICING

(1) Cylinder Head

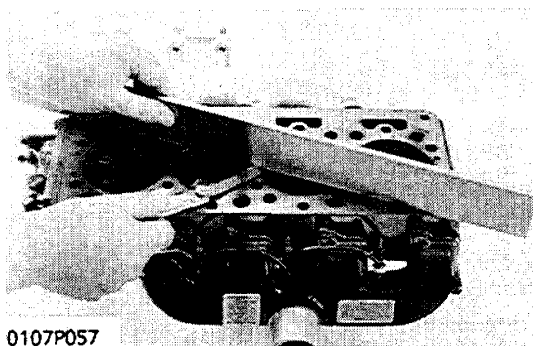

0107P057

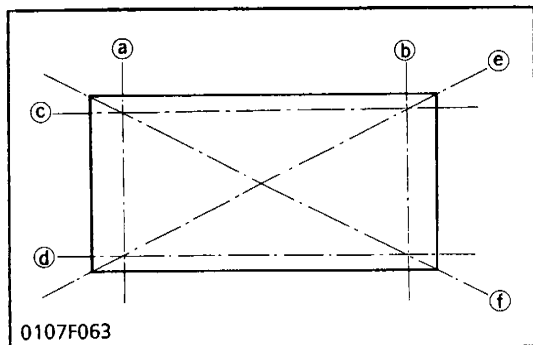

0107F063

Cylinder Head Surface Flatness

1. Clean the cylinder head surface.
2. Place a straight edge on the cylinder head and measure the clearance with a feeler gauge in the positions (a) to (f) as shown in the figure.

■ NOTE

- Be careful not to place a straight edge on the combustion chamber insert.

3. If the measurement exceeds the allowable limit, correct with a surface grinder.

■ IMPORTANT

- Be sure to check the top clearance after correcting.

Cylinder head surface flatness	Allowable limit	0.05 mm (0.0019 in.)
--------------------------------	-----------------	----------------------

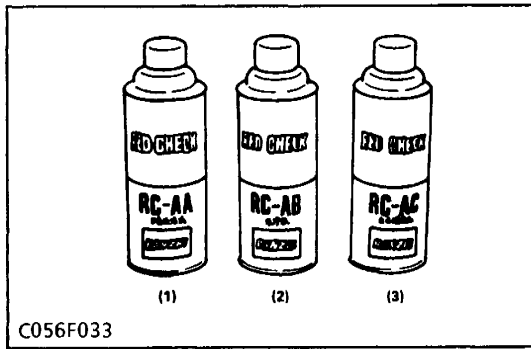

Cylinder Head Surface Flaw

1. Clean the surface of the cylinder head with detergent (1).
2. Spray the cylinder head surface with the red permeative liquid (2).
3. After ten minutes, wash away the red permeative liquid on the cylinder head surface with the detergent (1).
4. Spray the cylinder head surface with the white developer (3).
5. A flaw will show up as red marks.
If found flaw, replace the cylinder head.

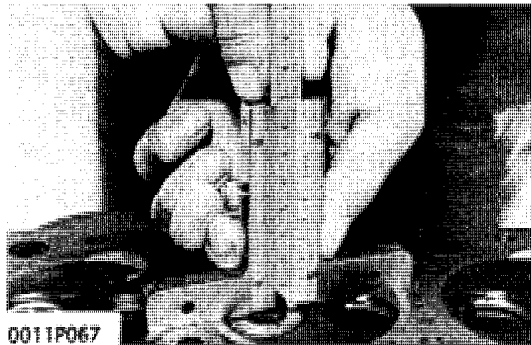

Valve Recessing

1. Clean the valve head.
2. Measure the recessing with a depth gauge.
3. If the measurement exceeds the allowable limit, replace the valve.

■ **NOTE**

- When replacing the valve, repair the valve seat.

Valve recessing	Factory spec.	0.9 to 1.1 mm 0.036 to 0.043 in.
	Allowable limit	1.3 mm 0.051 in.

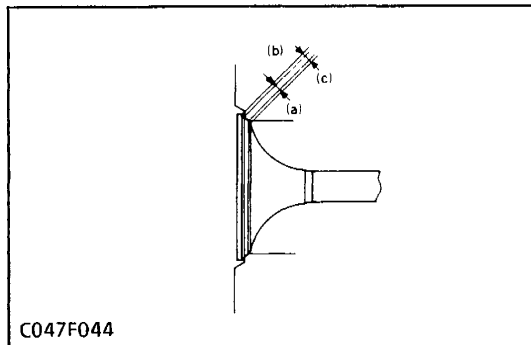

Width of Contact between Valve and Valve Seat

1. Check the contact between the valve face and the valve seat.
2. Either repair or replace the valve and valve seat, if the contact is uneven [(b) ≠ (c)] or the width (a) of contact is unusually large.
3. Check the sliding condition applying a compound after either repair or replacement.

Valve seat width (IN and EX.)	Factory spec.	2.12 mm 0.0835 in.
-------------------------------	---------------	-----------------------

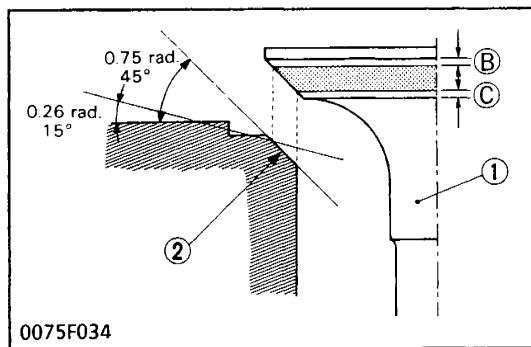

Correcting Valve and Valve Seat

1. Correct the valve seat to the factory specification using a valve seat cutter (Code No. 07909-33102) or a valve seat grinder.
2. Correct the valve using a valve refacer.

Valve seat angle (IN and EX.)	Factory spec.	0.785 rad. 45°
Valve face angle (IN and EX.)	Factory spec.	0.794 rad. 45.5°

(1) Valve

(2) Corrected Valve Seat

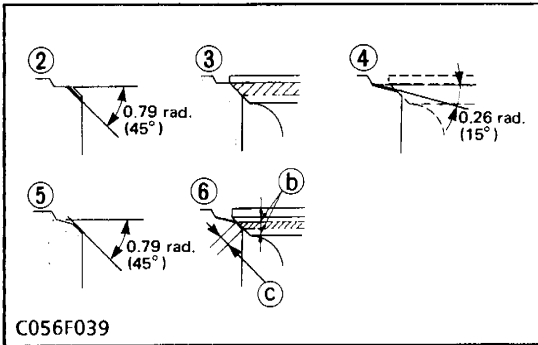
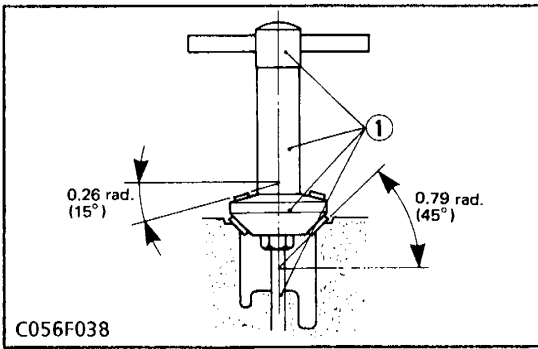

Correcting Procedure for Valve Seat

1. Correct the valve seat surface using a 0.79 rad. (45°) valve seat cutter (Valve seat cutter set: Code No. 07909-33102).
2. Place the valve and visually check the contact position between the valve face and valve seat with red lead. (If the valve has been used for a long period of time, the seat tends to come in contact with the upper side of the valve face.)
3. Cut the seat with a 0.26 rad. (15°) valve seat cutter so that the valve seat width makes contact in the same dimensions to the valve face width.
4. Cut the seat with a 0.79 rad. (45°) valve seat cutter again, and visually recheck the contact between the valve and seat.
5. Repeat steps 3, and 4. until the correct contact is achieved.
6. Continue lapping until the seated rate is more than 70% of the total contact area.

- | | |
|----------------------------|----------------------------|
| (1) Valve Seat Cutter | (5) 0.79 rad. (45°) Cutter |
| (2) 0.79 rad. (45°) Cutter | (6) Contact Check |
| (3) Contact Check | (b) Identical Dimensions |
| (4) 0.26 rad. (15°) Cutter | (c) Seat Surface Width |

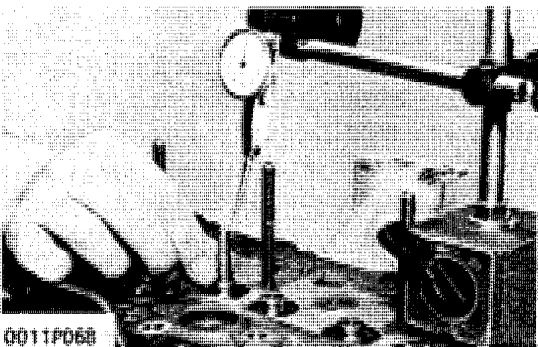

Clearance between Valve Stem and Valve Guide

1. Remove carbon from the valve guide.
2. Insert the valve into the valve guide.
3. Measure the clearance between valve stem and valve guide with a dial indicator.
4. If the measurement exceeds the allowable limit replace the valve guide and the valve.

Clearance between valve stem and valve guide	Factory spec.	0.035 to 0.065 mm 0.0014 to 0.0025 in.
	Allowable limit	0.1 mm 0.0039 in.
Valve stem O.D.	Factory spec.	6.960 to 6.975 mm 0.2741 to 0.2746 in.
Valve guide I.D.	Factory spec.	7.010 to 7.025 mm 0.2760 to 0.2765 in.

IMPORTANT

- After replacing the valve guide, be sure to ream to the dimensions described in the table.

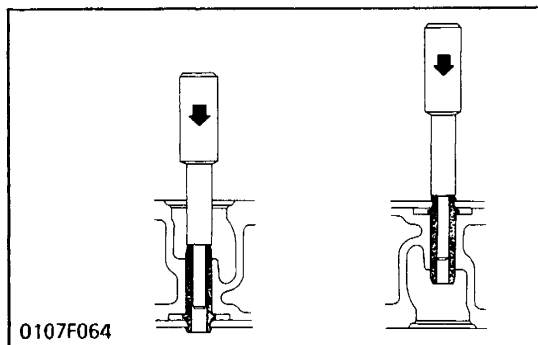

0107F064

Replacing Valve Guide

1. Press the used valve guide out from the cylinder head's lower side using a valve guide replacing tool (See page S.G-26).
2. Apply engine oil to the outer surface of the new valve guide, and press fit the valve guide from the cylinder head's upper side until the flange part of the valve guide contacts the cylinder head.
3. After press-fitting, finish the valve guide by means of reaming to dimensions shown in previous table.

NOTE

- Be careful not to strike valve guide with a hammer, etc. during replacement.

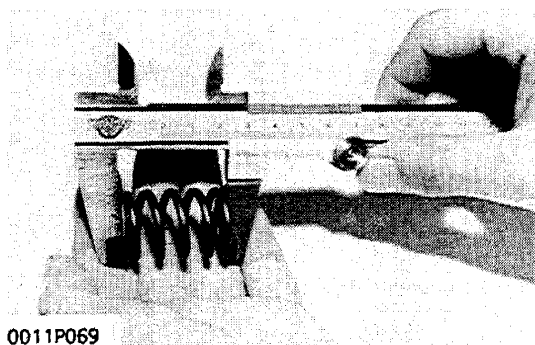

0011P069

Valve Spring Free Length

1. Measure the free length of the valve spring with vernier calipers.
2. If the measurement is less than the allowable limit, replace the valve spring.

Valve spring free length	Factory spec.	35.1 to 35.6 mm 1.382 to 1.401 in.
	Allowable limit	34.8 mm 1.370 in.

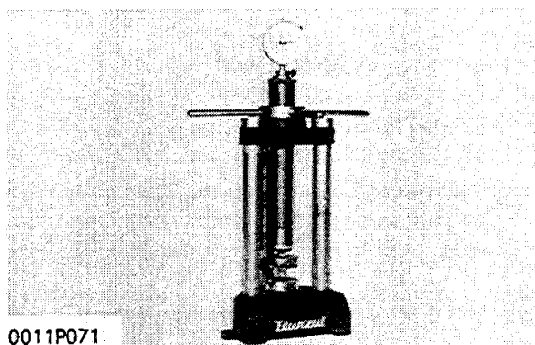

0011P071

Valve Spring Setting Load

1. Place the valve spring on the tester, and compress it to setting length (31 mm, 1.22 in.).
2. Read the compression load on the gauge.
3. If the measurement is less than the allowable limit, replace the valve spring.

Valve spring setting load	Factory spec.	73.5 N·m 7.5 kgf·m 16.5ft·lbs
	Factory spec.	62.8 N·m 6.4 kgf·m 14.1 ft·lbs

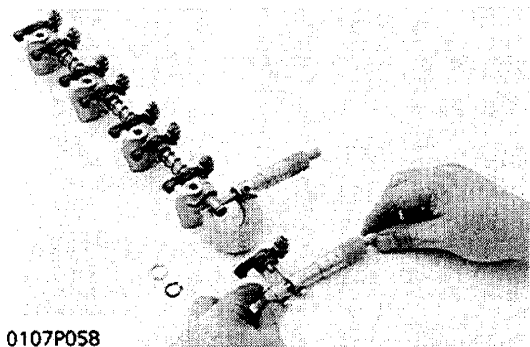
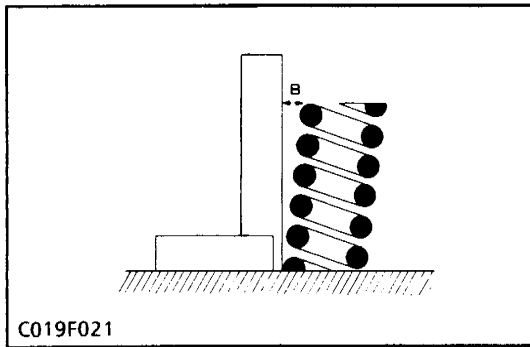
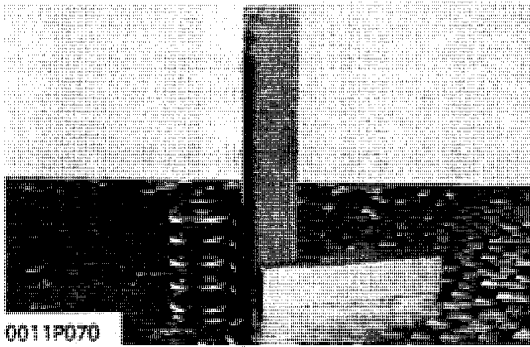

Valve Spring Tilt

1. Place the spring on a surface plate, place a square on the side of the spring, and check to see if the entire side is in contact with the square.
Rotate the spring and measure the maximum "B".
2. The flat surface at the end of the spring coil must exceed the full circumference by two-thirds.
3. Check the entire surface of the spring for scratches.
4. If the measurement exceeds the allowable limit, replace the valve spring.

Valve spring tilt	Allowable limit	1.3 mm 0.051 in.
-------------------	-----------------	---------------------

Clearance between Rocker Arm Shaft and Rocker Arm

1. Measure the rocker arm I.D. with an inside micrometer.
2. Measure the rocker arm shaft O.D. with an outside micrometer, and calculate the clearance.
3. If the clearance exceeds the allowable limit, replace them

Clearance between rocker arm shaft and rocker arm	Factory spec.	0.016 to 0.068 mm 0.0007 to 0.0026 in.
	Allowable limit	0.12mm 0.0047 in

Rocker arm shaft O.D.	Factory spec.	10.973 to 10.984 mm 0.4321 to 0.4324 in
-----------------------	---------------	--

Rocker arm I.D.	Factory spec.	11.000 to 11.041 mm 0.4331 to 0.4347 in
-----------------	---------------	--

(2) Timing Gear and Camshaft

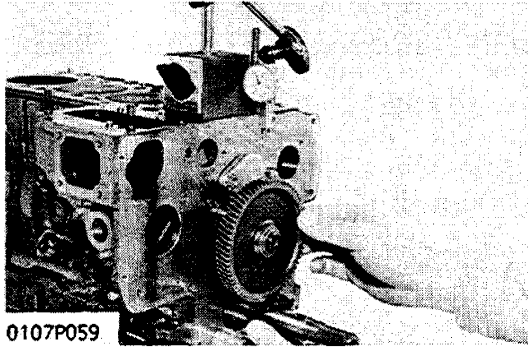

Timing Gear Backlash

1. Set the dial indicator (lever type) with its finger on the tooth of the gear.
2. Hold the mating gear, and measure the backlash by moving the gear.
3. If the backlash exceeds the allowable limit, replace the faulty part.

Timing gear backlash	Factory spec.	0.042 to 0.115 mm 0.0017 to 0.0045 in.
	Allowable limit	0.20 mm 0.0079 in.

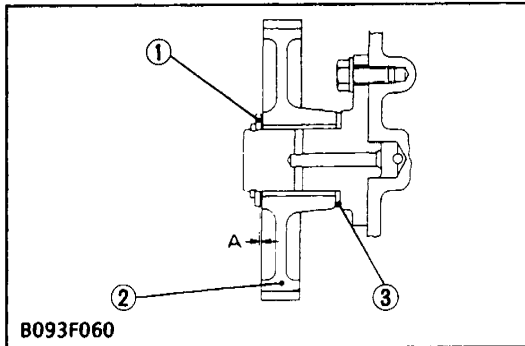

Idle Gear Side Clearance

1. Measure the clearance "A" between the idle gear collar 2 (1) and the idle gear (2) with a feeler gauge.
2. If the clearance exceeds the allowable limit, replace the idle gear collar 1 (3).

Idle gear side clearance	Factory spec.	0.20 to 0.51 mm 0.0079 to 0.0201 in.
	Allowable limit	0.80 mm 0.0315 in.

(1) Idle Gear Collar 2 (3) Idle Gear Collar 1
(2) Idle Gear

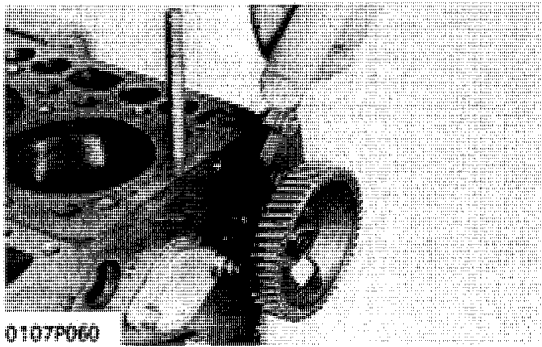

Camshaft Side Clearance

1. Pull the camshaft fully to the cam gear side.
2. Measure the clearance between the cam gear and the camshaft stopper.
3. If the clearance exceeds the allowable limit, replace the camshaft stopper.

Camshaft side clearance	Factory spec.	0.07 to 0.22 mm 0.0028 to 0.0087 in.
	Allowable limit	0.30 mm 0.0118 in.

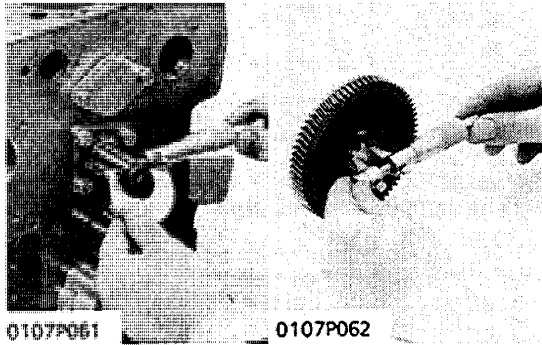

Clearance between Idle Gear Shaft and Idle Gear Bushing

1. Measure the idle gear shaft O.D. with an outside micrometer.
2. Measure the idle gear bushing I.D. with an inside micrometer, and calculate the clearance.
3. If the clearance exceeds the allowable limit, replace the bushing.

Clearance between idle gear shaft and idle gear bushing	Factory spec.	0.020 to 0.054 mm 0.0008 to 0.0021 in.
	Allowable limit	0.10 mm 0.039 in.

Idle gear shaft O.D.	Factory spec.	29.967 to 29.980 mm 1.1798 to 1.1803 in.
Idle gear bushing I.D.	Factory spec.	30.000 to 30.021 mm 1.1811 to 1.1819 in.

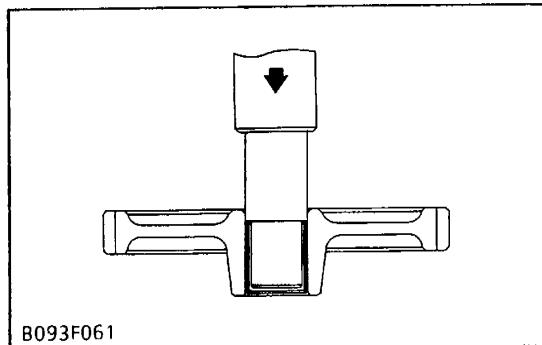

Replacing Idle Gear Bushings

1. Press the used bushings out using a idle gear bushing replacing tool (See page S.G-26).
2. Press fit new bushing.

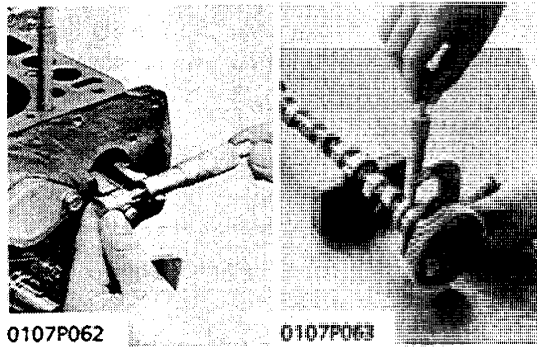

0107P062

0107P063

Oil Clearance of Camshaft

1. Measure the camshaft bearing I.D. with an inside micrometer.
2. Measure the camshaft journal O.D. with an outside micrometer, and calculate the oil clearance.
3. If the oil clearance exceeds the allowable limit, replace the camshaft.

Oil clearance of camshaft	Factory spec.	0.050 to 0.09 mm 0.0020 to 0.0035 in.
	Allowable limit	0.15 mm 0.0059 in.
Camshaft journal O.D.	Factory spec.	32.934 to 32.950 mm 1.2967 to 1.2972 in.
Camshaft bearing I.D.	Factory spec.	33.000 to 33.025 mm 1.2993 to 1.3002 in.

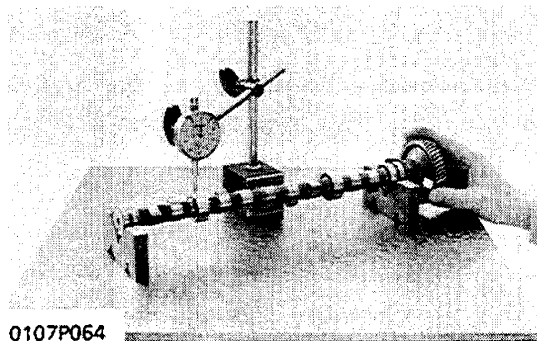

0107P064

Camshaft Alignment

1. Gently put the camshaft on V-blocks.
2. Set a dial indicator to the journal.
3. While slowly rotating the camshaft, read the dial indicator. The camshaft flexure is half of the reading.
4. If the measurement exceeds the allowable limit, replace the camshaft.

Camshaft alignment	Allowable limit	0.08 mm 0.0031 in.
--------------------	-----------------	-----------------------

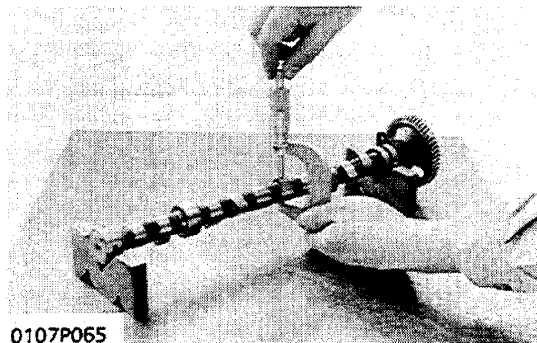

0107P065

Cam Heights of Inlet and Exhaust

1. Measure the height of the cam at its highest point with an outside micrometer.
2. If the measurement is less than the allowable limit, replace the camshaft.

Cam heights of inlet and exhaust	Factory spec.	26.88 mm 1.0583 in.
	Allowable limit	26.83mm 1.0563 in.

(3) Piston and Connecting Rod

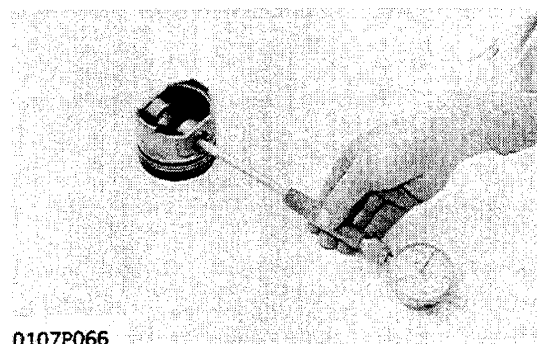

0107P066

Piston Pin-bore

1. Measure the piston pin-bore I.D. in both the vertical and horizontal direction with a cylinder gauge.
2. If the measurement exceeds the allowable limit, replace it.

Piston pin-bore	Factory spec.	20.000 to 20.013 mm 0.7874 to 0.7879 in.
	Allowable limit	20.03 mm 0.7886 in.

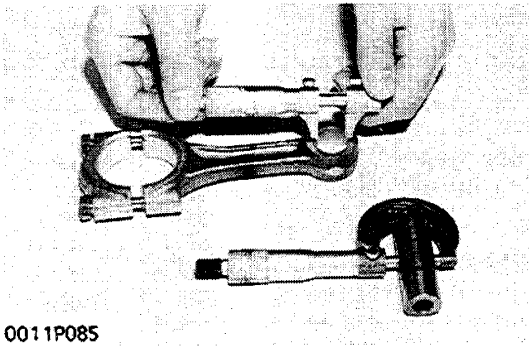

0011P085

Clearance between Piston Pin and Small End Bushing

1. Measure the piston pin O.D. with an outside micrometer.
2. Measure the small end bushing I.D. with an inside micrometer and calculate the clearance.
3. If the clearance exceeds the allowable limit, replace the bushing.

Clearance between piston pin and small end bushing	Factory spec.	0.014 to 0.038 mm 0.0006 to 0.0015 in.
	Allowable limit	0.15mm 0.0059 in.
Piston pin O.D.	Factory spec.	20.002 to 20.011 mm 0.7875 to 0.7878 in.
Small end bushing I.D.	Factory spec.	20.025 to 20.040 mm 0.7884 to 0.7889 in.

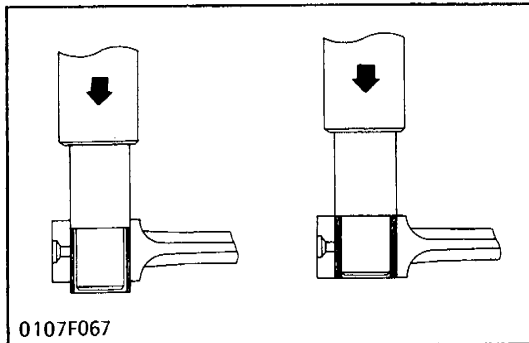

0107F067

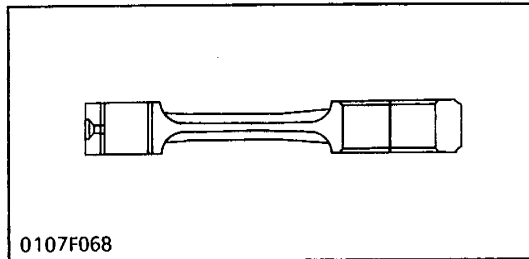

0107F068

Replacing Small End Bushing

1. Press the used bushing out using a small end bushing replacing tool (See page S.G-27).
2. Press fit a new bushing (Service parts: Code No. 15261-21981), taking due care to see that the connecting rod hole matches the bushing hole.

(Reference)

- Service parts dimension

Clearance between piston pin and small end bushing	Factory spec.	0.015 to 0.075 mm 0.0006 to 0.0029 in.
	Allowable limit	0.15 mm 0.0059 in.
Piston pin O.D.	Factory spec.	20.002 to 20.011 mm 0.7875 to 0.7878 in.
Small end bushing I.D.	Factory spec.	20.026 to 20.077 mm 0.7885 to 0.7904 in.

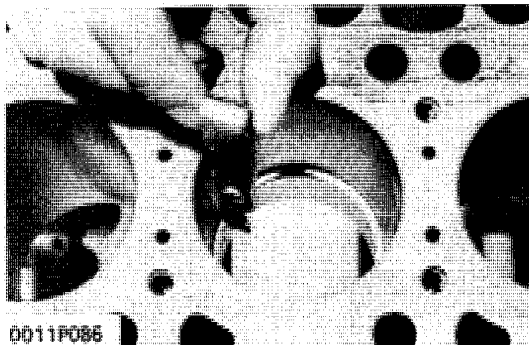

0011P086

Piston Ring Gap

1. Insert the piston ring into the lower part of the liner (least worn out part) using the piston ring compressor and the piston.
2. Measure the ring gap with a feeler gauge.
3. If the gap exceeds the allowable limit, replace the piston ring.

Piston ring gap	Compression ring 1	Factory spec.	0.20 to 0.35 mm 0.0079 to 0.0138 in.
		Allowable limit	1.25 mm 0.0492 in.
	Compression ring 2	Factory spec.	0.30 to 0.45 mm 0.0118 to 0.0177 in.
		Allowable limit	1.25 mm 0.492 in.
	Oil ring	Factory spec.	0.25 to 0.40 mm 0.0098 to 0.0157 in.
		Allowable limit	1.25 mm 0.0492 in.

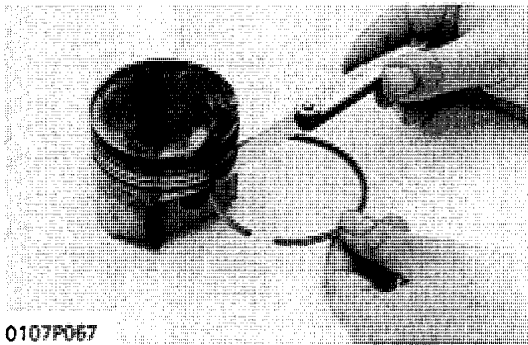

0107P067

Clearance between Piston Ring and Ring Groove

1. Insert the piston ring into the ring groove, and measure the clearance with a feeler gauge at several points.
2. If the clearance exceeds the allowable limit, replace the piston in order to avoid leakage of compressed air or oil.

Clearance between compression ring 2 and ring groove	Factory spec.	0.085 to 0.112 mm 0.0034 to 0.0044 in.
	Allowable limit	0.20 mm 0.0079 in.
Clearance between oil ring and ring groove	Factory spec.	0.020 to 0.055 mm 0.0008 to 0.0021 in.
	Allowable limit	0.20 mm 0.0079 in.

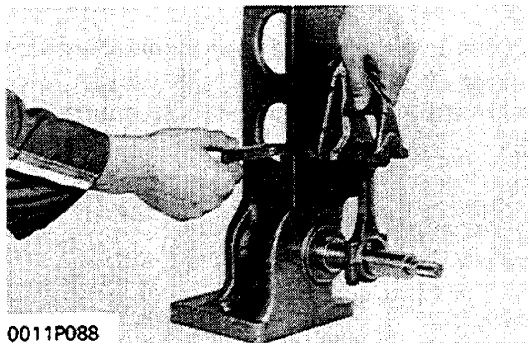

0011P088

Connecting Rod Alignment

1. Remove the connecting rod crank pin bearing and tighten the rod screws.
2. Set the connecting rod to a connecting rod aligner.
3. Put a piston pin into the connecting rod. Place the gauge on the piston pin.
4. Measure the gap between the pin of the gauge and the flat surface of the aligner with a feeler gauge.
5. If the measurement exceeds the allowable limit, replace the connecting rod.

Connecting rod alignment	Allowable limit	0.05 mm 0.0020 in.
--------------------------	-----------------	-----------------------

(4) Crankshaft

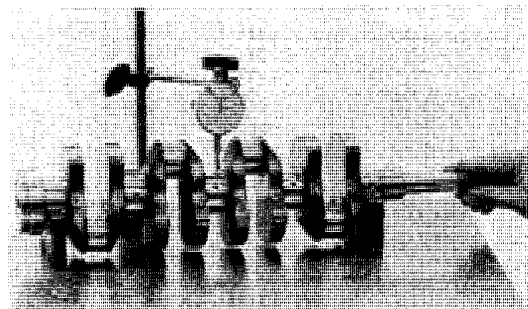

0107P068

Crankshaft Alignment

1. Place V-blocks on the surface plate, and support the journals at both ends of the crankshaft on the V-blocks.
2. Set a dial indicator to the central journal.
3. While slowly rotating the crankshaft, read the dial indicator. The crankshaft flexure is half of the reading.
4. If the flexure exceeds the allowable limit, replace it.

Crankshaft alignment	Allowable limit	0.08 mm 0.0031 in.
----------------------	-----------------	-----------------------

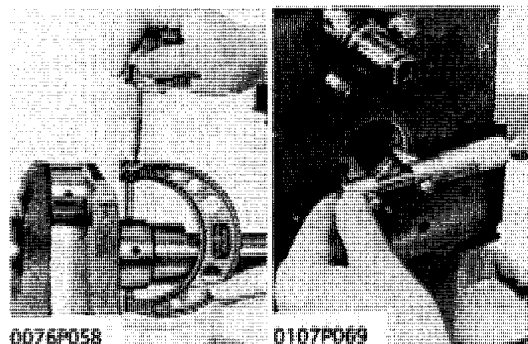

0076P058

0107P069

Oil Clearance between Crankshaft and Crankshaft Bearing 1

1. Measure the crankshaft O.D. with an outside micrometer.
2. Measure the crankshaft bearing 1 I.D. with an inside micrometer, and calculate the oil clearance.
3. If the oil clearance exceeds the allowable limit, replace the crankshaft bearing 1.

Oil clearance between crankshaft and crankshaft bearing 1	Factory spec.	0.034 to 0.106 mm 0.0014 to 0.0041 in.
	Allowable limit	0.20 mm 0.0079 in.

Crankshaft O.D.	Factory spec.	43.934 to 43.950 mm 1.7297 to 1.7303 in.
Crankshaft bearing 1 I.D.	Factory spec.	43.984 to 44.040 mm 1.7317 to 1.7338 in.

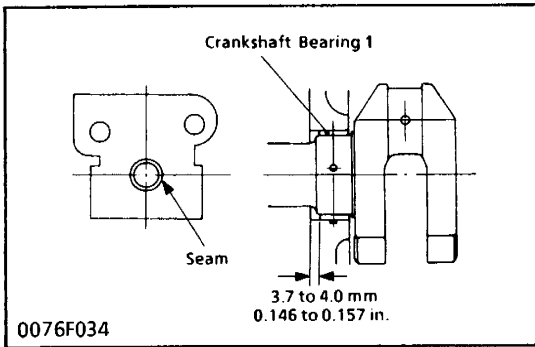

Replacing Crankshaft Bearing 1

1. Press the used bearing 1 out using a removing tool (See page S.G-27).
2. Press fit a new bearing 1 using a inserting tool, taking due care to see that the seam of bearing 1 faces the exhaust manifold side.

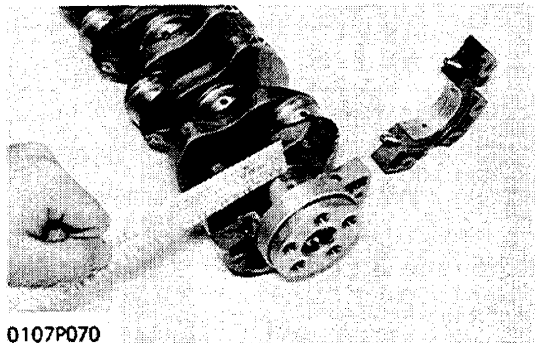

Oil Clearance between Crankshaft and Crankshaft Bearing 2

1. Put a press gauge on the crankshaft bearing 2.
2. Tighten the bearing case screws 1 to specified torque (19.6 to 23.5 N·m, 2.0 to 2.4 kgf·m, 14.5 to 17.4 ft-lbs).
3. Remove the main bearing case gently, and measure the width of the press gauge with a sheet of gauge (paper).
4. If the measurement exceeds the allowable limit, replace the crankshaft bearing 2.

NOTE

- Do not insert the press gauge into the oil hole.
- Fasten the crankshaft so that it does not turn.

Oil clearance between crankshaft and crankshaft bearing 2	Factory spec.	0.034 to 0.092 mm 0.0014 to 0.0036 in.
	Allowable limit	0.20 mm 0.0079 in.
Crankshaft O.D.	Factory spec.	43.934 to 43.950 mm 1.7297 to 1.7303 in.
Crankshaft bearing 2 I.D.	Factory spec.	43.984 to 44.026 mm 1.7317 to 1.7333 in.

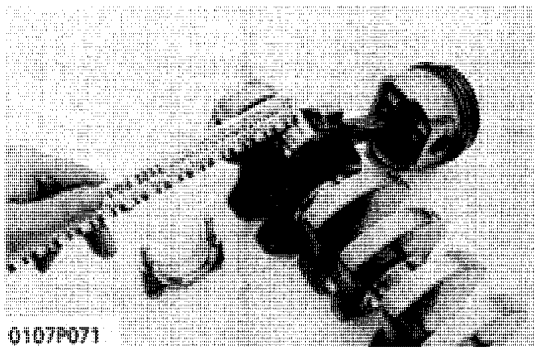

Oil Clearance between Crank Pin and Crank Pin Bearing

1. Put a press gauge on the crank pin bearing.
2. Tighten the connecting rod screws to specified torque (26.5 to 30.4 N·m, 2.7 to 3.1 kgf·m, 19.5 to 22.4 ft-lbs).
3. Remove the connecting rod cap gently, and measure the width of the press gauge with a sheet of gauge (paper).
4. If the measurement exceeds the allowable limit, replace the crank pin bearing.

Oil clearance between crank pin and crank pin bearing	Factory spec.	0.029 to 0.087 mm 0.0012 to 0.0034 in.
	Allowable limit	0.20 mm 0.0079 in.
Crank pin O.D.	Factory spec.	36.959 to 36.975 mm 1.4551 to 1.4557 in.
Crank pin bearing I.D.	Factory spec.	37.004 to 37.046 mm 1.4569 to 1.4585 in.

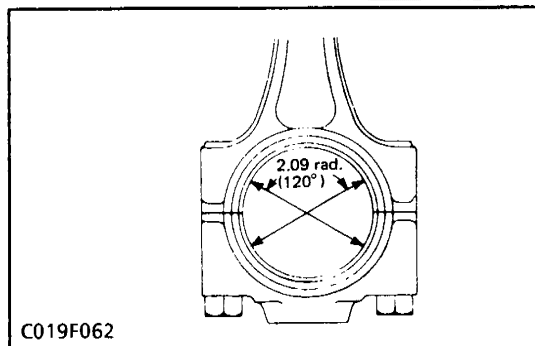

NOTE

- Do not insert the press gauge into the crank pin oil hole.
- Fasten the crankshaft so that it does not turn.
- Measuring points are shown in the figure.

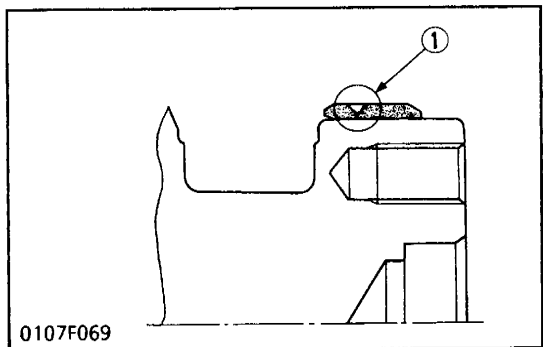

0107F069

(1) Wear

Crankshaft Sleeve Wear

1. Measure the wear of the crankshaft sleeve using a surface roughness tester.
2. If the measurement exceeds the allowable limit, replace the crankshaft sleeve.

Crankshaft sleeve wear	Allowable limit	0.1 mm 0.0039 in.
------------------------	-----------------	----------------------

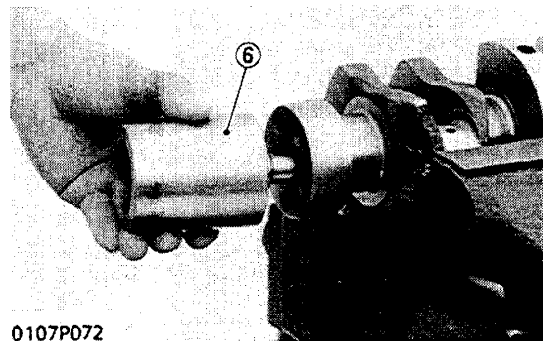

0107P072

Replacing Crankshaft Sleeve

1. Remove the used crankshaft sleeve using a special-use puller set (Code No. 07916-09032).
2. Set the sleeve guide C (6) to the crankshaft.
3. Set the stopper (7) to the crankshaft as shown in the figure.
4. Heat a new sleeve to a temperature between 150 and 200°C (302 and 392°F), and fix the sleeve to the crankshaft as shown in the figure.
5. Press fit the sleeve using the auxiliary socket for pushing (3).

TOOL

- Auxiliary socket for fixing the crankshaft sleeve (Code No. 07916-33011)

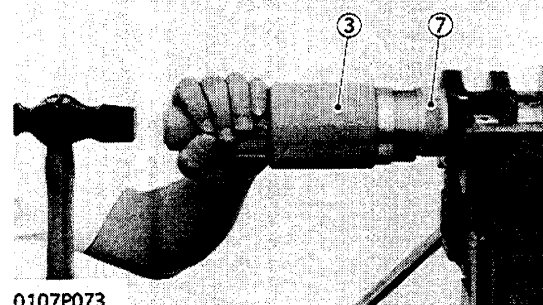

0107P073

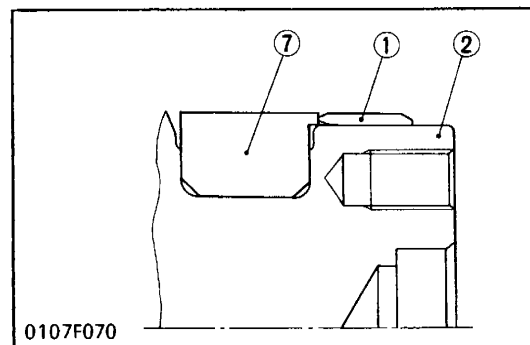

0107F070

- | | |
|----------------------------------|--------------------|
| (1) Crankshaft Sleeve | (5) Stopper B |
| (2) Crankshaft | (6) Sleeve Guide C |
| (3) Auxiliary Socket for Pushing | (7) Stopper C |
| (4) Sleeve Guide B | |

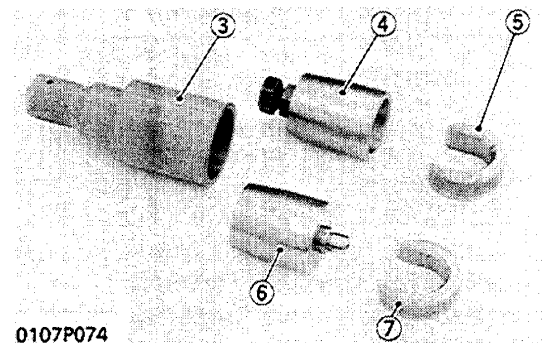

0107P074

Crankshaft Side Clearance

1. Push the crankshaft fully to the flywheel side.
2. Set a dial indicator to the crankshaft.
3. Pull the crankshaft toward the gear case and measure the side clearance.
4. If the measurement exceeds the allowable limit, replace the thrust bearing.

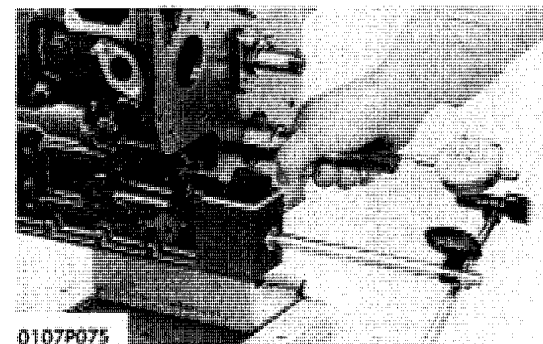

0107P075

Crankshaft side clearance	Factory spec.	0.15 to 0.31 mm 0.0059 to 0.0122 in.
	Allowable limit	0.50 mm 0.0197 in.

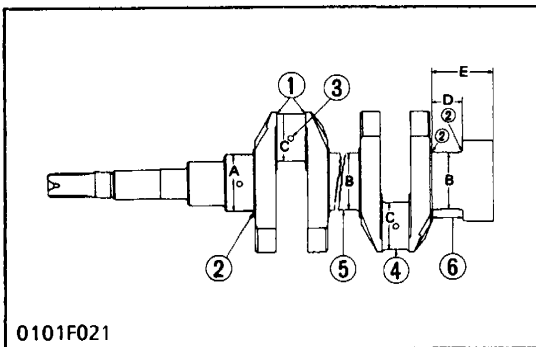

Undersized and Oversized Bearing

If the standard-size bearing cannot be employed due to excessive wear of the crank pin and crank journal, employ undersize or oversize bearings.

For undersize or oversize bearing use, follow the precautions noted below.

- Grind the crankpin and journal with a wheel which has specified round corner and width without shoulder.
- (1) 3.3 to 3.7 mm (0.1300 to 0.1457 in.) Radius
- (2) 2.8 to 3.2 mm (0.1102 to 0.1260 in.) Radius
- (3) Be sure to chamfer the oil hole circumference to 1.0 to 1.5 mm (0.04 to 0.06 in.) radius with an oil stone.
- (4) The crankpin must be fine-finished.
- (5) The crank journal must be fine-finished.
- (6) The crank journal side surface must be fine-finished.

Undersize, Oversize	Code No.	Name of Bearing	Bearing Mark	Crankshaft Processing Dimension	
- 0.2 mm - 0.008 in.	15261-2391-1	Crankshaft Bearing 1 (0.2 minus)	020 US	A	43.734 to 43.750 mm 1.72181 to 1.72244 in.
- 0.4 mm - 0.016 in.	15261-2392-1	Crankshaft Bearing 1 (0.4 minus)	040 US		43.534 to 43.550 mm 1.71394 to 1.71457 in.
- 0.2 mm - 0.008 in.	15261-2393-1	Crankshaft Bearing 2 (0.2 minus)	020 US	B	43.734 to 43.750 mm 1.72181 to 1.72244 in.
- 0.4 mm - 0.016 in.	15261-2394-1	Crankshaft Bearing 2 (0.4 minus)	040 US		43.534 to 43.550 mm 1.71394 to 1.71457 in.
- 0.2 mm - 0.008 in.	15531-2297-1	Crank Pin Bearing (0.2 minus)	020 US	C	36.759 to 36.775 mm 1.44720 to 1.44783 in.
- 0.4 mm - 0.016 in.	15531-2298-1	Crank Pin Bearing (0.4 minus)	040 US		36.559 to 36.575 mm 1.43933 to 1.43996 in.
+ 0.2 mm + 0.008 in.	15261-2395-1	Thrust Bearing 1 (0.2 plus)	020 OS	D	24.40 to 24.45 mm 0.9763 to 0.9783 in.
	15261-2397-1	Thrust Bearing 2 (0.2 plus)		E	48.1 to 48.3 mm 1.894 to 1.902 in.
+ 0.4 mm + 0.016 in.	15261-2396-1	Thrust Bearing 1 (0.4 plus)	040 OS	D	24.80 to 24.85 mm 0.9763 to 0.9783 in.
	15261-2398-1	Thrust Bearing 2 (0.4 plus)		E	48.3 to 48.5 mm 1.902 to 1.909 in.

NOTE ※1 (from page S.1-41.)

- Crankcase for model below was changed from with cylinder liner type to linerless type.

B1550 (HST) (D850-5B)	Engine S/N above 755815
-----------------------	----------------------------

- When cylinder wear of the linerless type engine exceeds 0.5 mm, the conventional cylinder liner can be installed for servicing.

(Reference)

- Cylinder liner installation procedure is as follows.
- (1) Bore and finish the crankcase cylinder to the dimension specified below. Chamfer the upper cylinder area to C0.1 to C0.2 mm.

Model	Reference value	Finishing
D850-5B	75.000 to 75.019 mm (2.9528 to 2.9535 in.)	6.3 μmR max. 0.000248 in R max.

- (2) Clean matching surface of the liner and crankcase cylinder, then apply engine oil.
- (3) Press in the cylinder liner into the crankcase cylinder in position.
- (4) Bore and hone to finish the cylinder liner to the dimension specified in the Table 1.
- (5) Install the standard piston and piston ring.

Table 1

Model	Reference value	Finishing
D850-5B	72.000 to 72.019 mm 2.8346 to 2.8353 in.	Hone to 1.2 to 2 μR max. 0.000047 to 0.000079 in. R max.

(5) Cylinder Liner

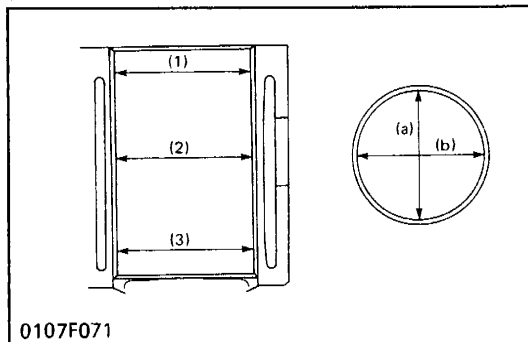
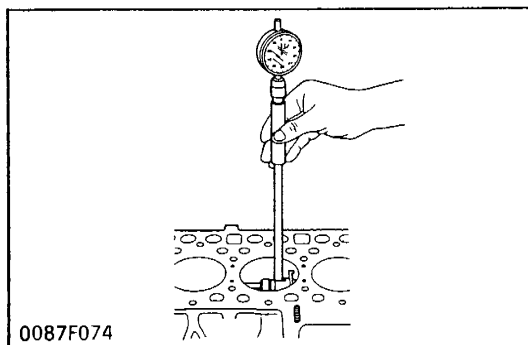

(a) Right Angle to Piston Pin (b) Parallel to Piston Pin

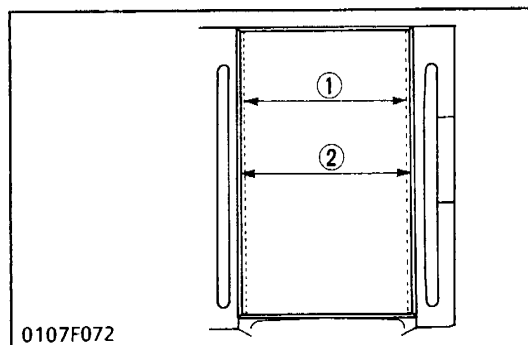

(1) Cylinder Liner I.D. (Before Correcting) (2) Oversized Cylinder Liner I.D.

■ IMPORTANT

- When the oversized cylinder liner is worn beyond the allowable limit, replace the cylinder liner and bore and hone it.

Cylinder Liner Wear

1. Measure the cylinder liner I.D. at the six points shown in the figure in order to find out the maximum wear.
2. If the measurement exceeds the allowable limit, bore and hone the cylinder liner.

[D850-5B] (※ 1) Refer to page S.1-40.

Cylinder liner I.D.	Factory spec.	72.000 to 72.019 mm 2.8347 to 2.8354 in.
	Allowable limit	72.169 mm 2.8413 in.
Cylinder liner wear	Allowable limit	0.15 mm 0.0059 in.

[D950-5B-V1200-5B]

Cylinder liner I.D.	Factory spec.	75.000 to 75.019 mm 2.9528 to 2.9535 in.
	Allowable limit	75.169 mm 2.9594 in.
Cylinder liner wear	Allowable limit	0.15 mm 0.0059 in.

[D850-5B]

Oversized cylinder liner I.D.	Factory spec.	72.500 to 72.519 mm 2.8543 to 2.8551 in.
	Allowable limit	72.669 mm 2.8610 in.
Cylinder liner wear	Allowable limit	0.15 mm 0.0059 in.

[D950-5B-V1200-5B]

Oversized cylinder liner I.D.	Factory spec.	75.500 to 75.519 mm 2.9725 to 2.9732 in.
	Allowable limit	75.669 mm 2.9791 in.
Cylinder liner wear	Allowable limit	0.15 mm 0.0059 in.

- The cylinder liner which has been oversized should use a piston and a ring assembly of the same oversize.

[D950-5B]

Piston 05 for No.1 and No.3 Cyl.

Piston 2 05 for No.2 Cyl.

[V1200-5B]

Piston 05 for No.1 and No.4 Cyl.

Piston 2 05 for No.2 and No.3 Cyl.

		Code No.			Mark
Enlarge	Part name	D850	D950	V1200	0505
0.5 mm 0.0197 in.	Piston 05	15956-2191-0	15532-2191-0	←	
	Piston 2 05	-	15531-2192-2	←	
	Piston ring assembly 05	15901-2109-0	15531-2109-0	15442 2109-0	

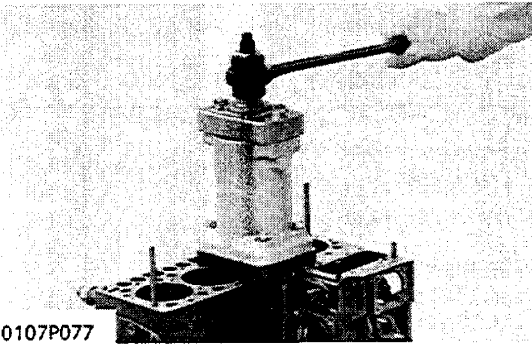

Replacing Cylinder Liner

1. Attach the dry liner changer-II (Code No. 07916-33081) to the cylinder block. (See the Kubota Repairing Tools Catalogue for details).
2. Pull out the cylinder liner.
3. Press-fit a new cylinder liner.

■ IMPORTANT

- Clean and oil the outside surface of the liner and the frame holes into which the liner is to be fitted.
- Insert the liner with the most chamfered end downward as shown in the figure.
- After inserting the cylinder liner, bore and hone to the standard size.

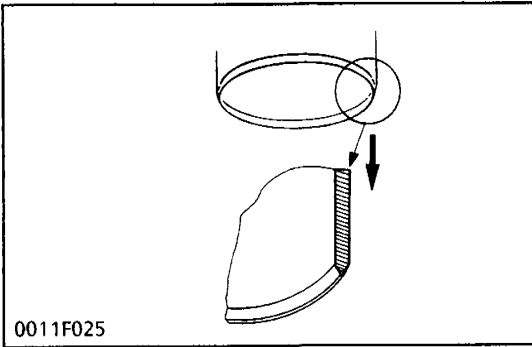

[2] LUBRICATING SYSTEM CHECKING

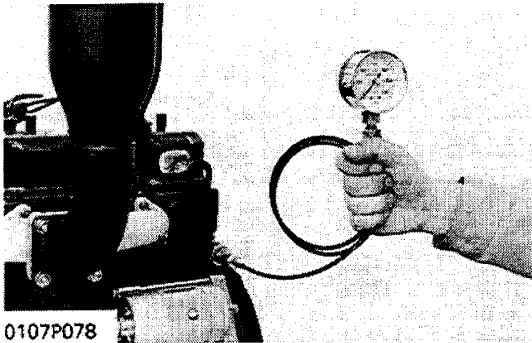

Engine Oil Pressure

1. Remove the oil switch and set a pressure tester (Code No. 07916-32031).
2. Start the engine. Measure the oil pressure both at idling and at the rated speed.
3. If the measurement is less than the allowable limit, check the oil pump, oil gallery, oil clearance and relief valve.

Engine oil pressure	Factory spec.	At rated speed	D850-5B	245 to 343 kPa 2.5 to 3.5 kgf/cm ² 36 to 49 psi
			D950-5B V1200-5B	167 to 294 kPa 1.7 to 3.0 kgf/cm ² 24 to 43 psi
		At idle speed	All	69 kPa 0.7 kgf/cm ² , 10 psi
	Allowable limit	At rated speed	D850-5B	245 kPa 2.5 kgf/cm ² , 36 psi
D950-5B V1200-5B			167 kPa 1.7 kgf/cm ² , 24 psi	

DISASSEMBLING AND ASSEMBLING

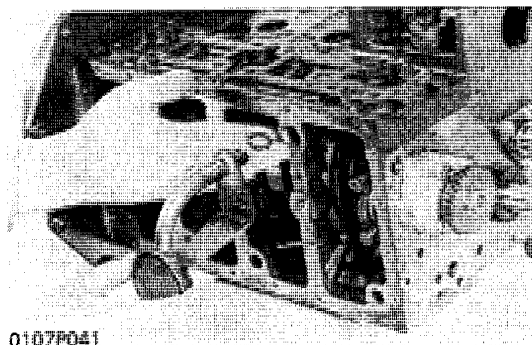

Oil Strainer

1. For removing the oil strainer, see page S.1-21.

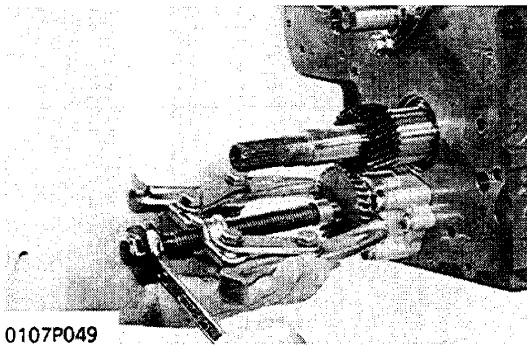

0107P049

Oil Pump

1. For removing the oil pump, see page S.1-25.

SERVICING

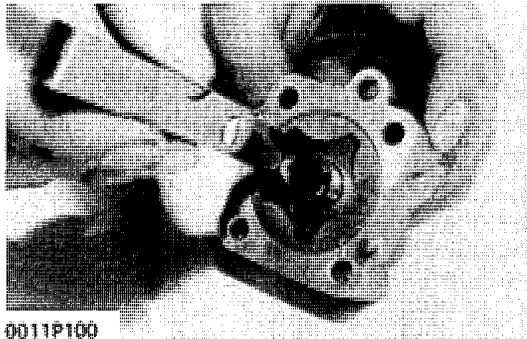

0011P100

Clearance between Inner Rotor and Outer Rotor

1. Measure the clearance between the inner and outer rotors with a feeler gauge.
2. If the clearance exceeds the allowable limit, replace the oil pump.

Clearance between inner rotor and outer rotor	Factory spec.	0.11 to 0.15 mm 0.0043 to 0.0059 in.
	Allowable limit	0.20 mm 0.0079 in.

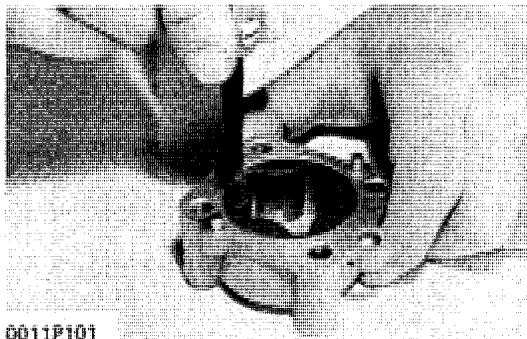

0011P101

Clearance between Outer Rotor and Pump Body

1. Measure the clearance between the outer rotor and pump body with a feeler gauge.
2. If the clearance exceeds the allowable limit, replace the oil pump.

Clearance between outer rotor and pump body	Factory spec.	0.07 to 0.15 mm 0.0028 to 0.0059 in.
	Allowable limit	0.25 mm 0.0098 in.

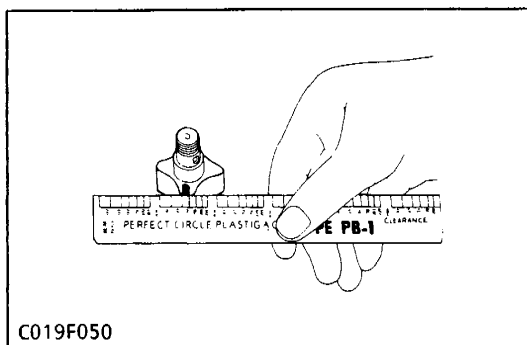

C019F050

End Clearance between Inner Rotor and Cover

1. Put a press gauge to the surface of the inner rotor.
2. Attach the cover.
3. Remove the cover gently, and measure the width of the press gauge with a sheet of gauge (paper).
4. If the measurement is not within the factory specifications, replace the oil pump.

End clearance between inner rotor and cover	Factory spec.	0.08 to 0.13 mm 0.0031 to 0.0051 in.
---	---------------	---

[3] COOLING SYSTEM

CHECKING AND ADJUSTING

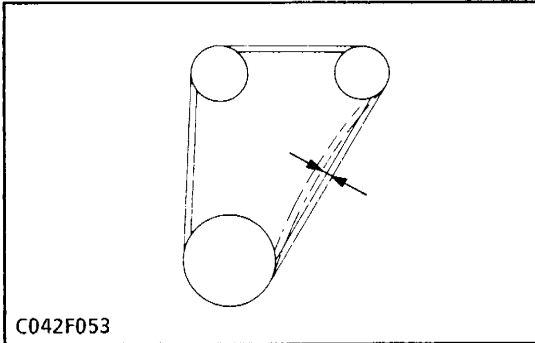

Fan Belt Tension

1. Check to see if the belt tension allows a depression of the specified amount when the belt is pressed down by the finger at halfway between the fan drive pulley and the AC dynamo pulley.
2. If tension is not within the factory specifications, adjust the tension by moving the AC dynamo.

Fan belt tension	Factory spec.	10 mm / 98 N, 10 kgf 0.4 in. / 22 lbs
------------------	---------------	--

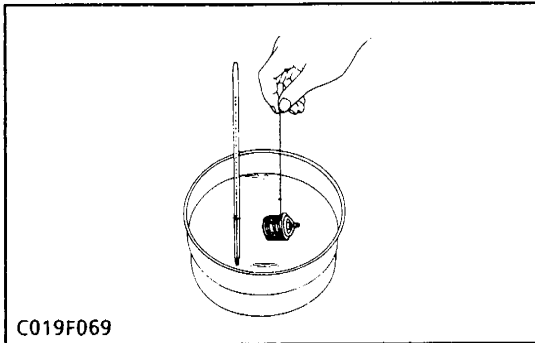

Thermostat's Valve Opening Temperature

1. Push down the thermostat valve and insert a string between the valve and the valve seat.
2. Place the thermostat and a thermometer in a container with water and gradually heat the water.
3. Hold the string to suspend the thermostat in the water. When the water temperature rises, the thermostat valve will open, allowing it to fall down from the string. Read the temperature at this moment on the thermometer.
4. Continue heating the water and read the temperature when the valve has risen by about 6 mm (0.236 in.).
5. If the measurement is not acceptable, replace the thermostat.

Thermostat's valve opening temperature	Factory spec.	80.5 to 83.5°C 176.9 to 182.3°F
Temperature at which thermostat completely opens	Factory spec.	95°C 203°F

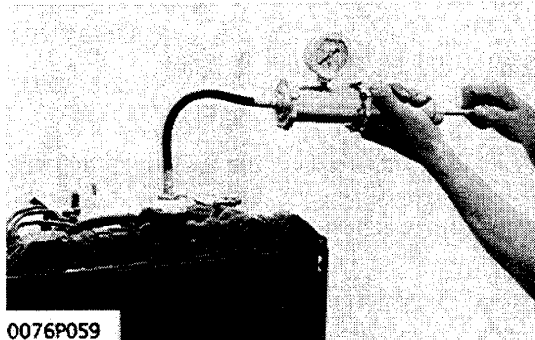

Radiator Water Tightness

1. Pour the specified amount of water into the radiator.
2. Warm up the engine.
3. Set a radiator tester. Increase the water pressure to the specified pressure 137 kPa (1.4 kgf/cm², 20 psi).
4. Check to see if the water leaks from any part.
5. If the water leaks, replace the radiator.
If the water leaks from a pin hole, mend it with the radiator cement.

Radiator water tightness	Factory spec.	No leaks at 137 kPa, 1.4 kgf/cm ² 20 psi
--------------------------	---------------	--

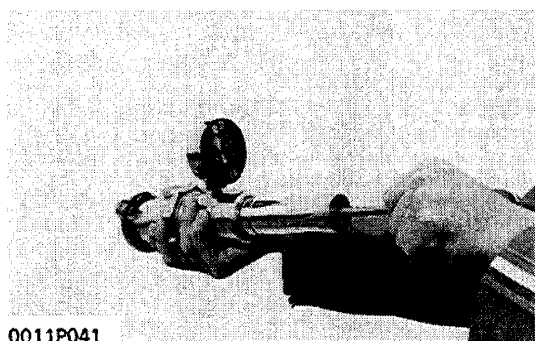

Radiator Cap Opening Pressure

1. Set a radiator tester to the radiator cap.
2. Apply the specified pressure 88 kPa (0.9 kgf/cm², 13 psi).
3. Measure the time needed to decrease the pressure from 88 to 59 kPa (from 0.9 to 0.6 kgf/cm², from 13 to 9 psi).
4. If the measurement is not within the factory specification, replace the radiator cap with a new one.

Radiator cap opening pressure	Factory spec.	10 seconds or more 88 → 59 kPa 0.9 → 0.6 kgf/cm ² 13 → 9 psi
-------------------------------	---------------	--

DISASSEMBLING AND ASSEMBLING

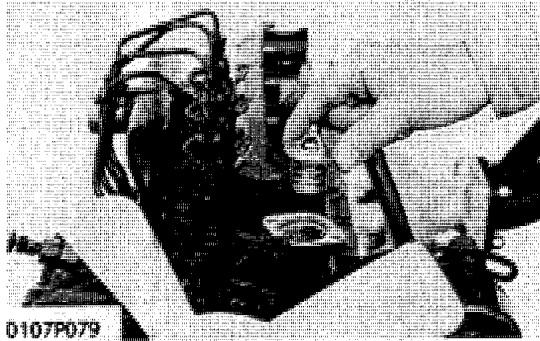

0107P079

Thermostat

1. Remove the thermostat cover.
2. Remove the thermostat.

(When reassembling)

- Apply a liquid gasket (Three Bond 1215 or equivalent) only at the thermostat cover side of the gasket.

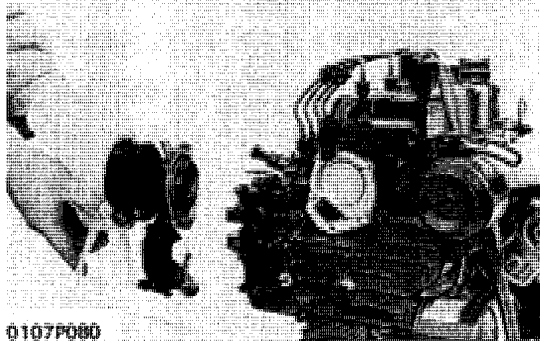

0107F080

Water Pump

1. Remove the water pump from gear case cover.
2. Remove the fan and fan pulley.
3. Remove the water pump flange (1).
4. Press out the water pump shaft (2) with the impeller (5) on it.
5. Remove the impeller from the water pump shaft.
6. Remove the mechanical seal (4).

(When reassembling)

- Apply a liquid gasket (Three Bond 1215 or equivalent) to the water pump gasket.
- Replace the mechanical seal with new one.

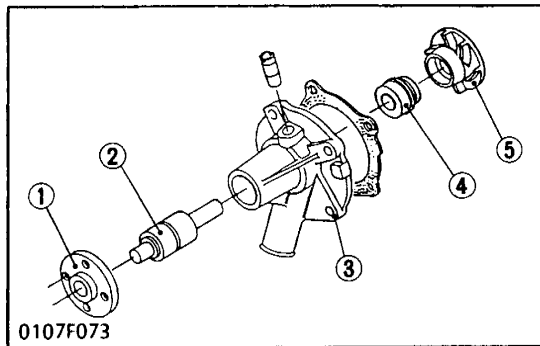

0107F073

- | | |
|-----------------------|---------------------|
| (1) Water Pump Flange | (4) Mechanical Seal |
| (2) Water Pump Shaft | (5) Impeller |
| (3) Water Pump Body | |

[3] COOLING SYSTEM (Alternator type for Canada)

CHECKING AND ADJUSTING

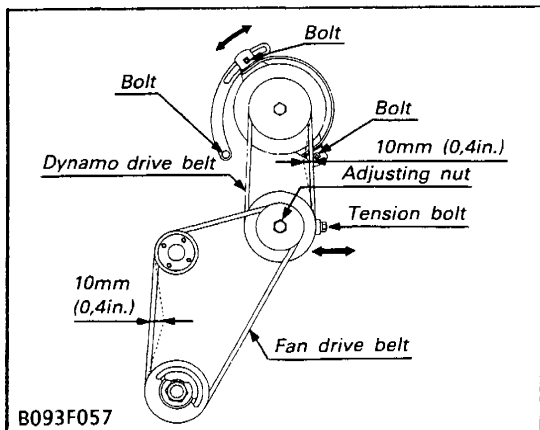

B093F057

Fan Belt Tension

1. Check to see if the belt tension allows a depression of the specified amount when the belt is pressed down by the finger at halfway between the fan drive pulley and the tension pulley.
2. If tension is not within the factory specifications, adjust the tension by moving the tension pulley.

Fan belt tension	Factory spec.	10 mm / 98 N, 10 kgf 0.4 in. / 22 lbs
------------------	---------------	--

NOTE

- The other items are shown in the left page.

[4] FUEL SYSTEM

CHECKING AND ADJUSTING

(1) Injection Pump

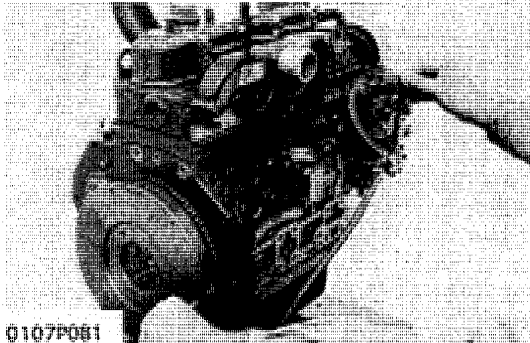

0107P081

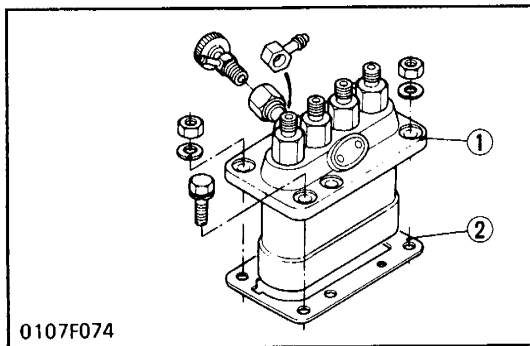

0107F074

(1) Injection Pump

(2) Shims

Injection Timing

1. Remove the injection pipes.
2. Set the speed control lever for maximum fuel discharge.
3. Turn the flywheel counterclockwise until fuel flows from the delivery valve holder.
4. Continue to turn the flywheel slowly, and stop it as soon as the fuel level at the tip of the delivery valve holder begins to increase.
5. Check to see if the mark (FI) on the flywheel is aligned with the punch mark.
6. If the timing is out of adjustment, readjust the timing with shims (2).

	Model	Factory spec.
Injection timing	D850-5B D950-5B	0.349 to 0.384 rad. (20° to 22°) before T.D.C
	V1200-5B	0.366 to 0.402 rad. (21° to 23°) before T.D.C

NOTE

- Adding or removing one shim (0.15 mm, 0.0059 in.) varies the crank angle by approx. 0.026 rad. (1.5°).

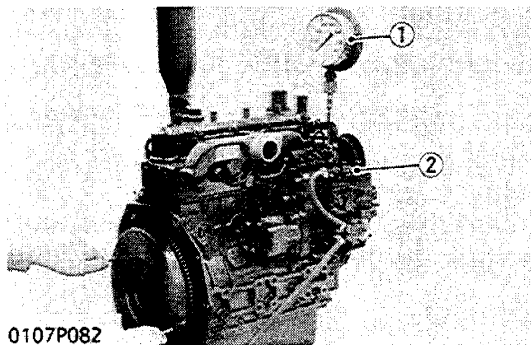

0107P082

Fuel Tightness of Pump Element

1. Set a pressure tester (1) (See page S.G-25) to the fuel injection pump (2).
2. Rotate the flywheel counterclockwise to increase the pressure to 39.23 MPa (400 kgf/cm², 5689 psi).
3. Measure the time needed to decrease the pressure from 39.23 to 34.32 MPa (from 400 to 350 kgf/cm², from 5689 to 4978 psi).
4. If the measurement is less than the allowable limit, replace the pump element or the injection pump assembly.

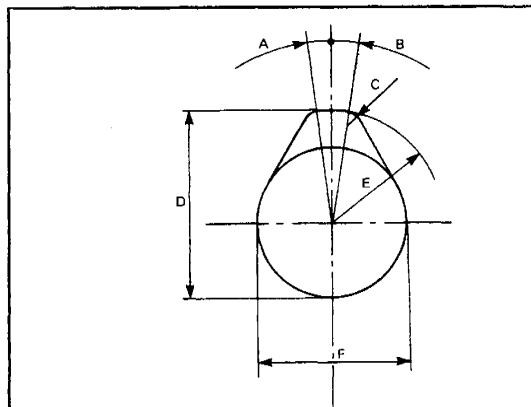

0107F075

A	0.12 rad. (7°)
B	0.12 rad. (7°)
C	3 mm (0.118 in.)
D	35 mm (1.378 in.)
E	21 mm (0.827 in.)
F	28 mm (1.102 in.)

Cam profile: PFK-T-00

(1) Pressure Tester (2) Injection Pump

Fuel tightness of pump element	Factory spec.	60 seconds or more 39.23 MPa → 34.32 MPa 400 kgf/cm ² → 350 kgf/cm ² 5689 psi → 4978 psi
	Allowable limit	30 seconds 39.23 MPa → 34.32 MPa 400 kgf/cm ² → 350 kgf/cm ² 5689 psi → 4978 psi

IMPORTANT

- After replacing the pump element, be sure to adjust the amount of fuel injected using a pump tester and a test bench [ZEXEL Corporation: Code No. 105760-0010 (for 50 Hz) or 105760-0020 (for 60 Hz)].

[Test Conditions]

Driving stand	ZEXEL Corporation: Code No. 105781-4160
Nozzle	DN12SD12T
Opening pressure	11.77 MPa 120 kgf/cm ² 1707 psi
Injection pipe	6 mm dia. x 2 mm dia. x 600 mm long 0.24 in. dia. x 0.08 in. dia. x 23.62 in. long
Fuel feed pressure	49 kPa 0.5 kgf/cm ² 7 psi
Test fuel	Diesel fuel No. 2-D
Pre-stroke	2.15 to 2.25 mm 0.0846 to 0.0886 in.
Cam profile	PFK-T-00

[Adjustment Reference Data]

Control rack position (mm)	Speed (r.p.m)	Amount of fuel (cc/100st)
a + 2	1400	2.21 to 2.55
a	1400	1.52 to 1.58
a - 1	1400	0.95 to 1.35
a - 1	400	0.45 to 0.77

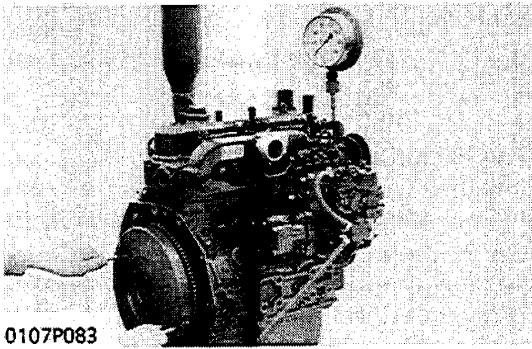

0107P083

Fuel Tightness of Delivery Valve

1. Set a pressure tester (See page S.G-25) to the fuel injection pump.
2. Rotate the flywheel to increase the pressure to 21.57 MPa (220 kgf/cm², 3129 psi).
3. Align the plunger with the bottom dead center.
4. Measure the time needed to decrease the pressure from 21.57 to 20.59 MPa (from 220 to 210 kgf/cm², from 3129 to 2987 psi).
5. If the measurement is less than allowable limit, replace the delivery valve.

Fuel tightness of delivery valve.	Factory spec.	10 seconds or more 21.57 MPa → 20.59 MPa 220 kgf/cm ² → 210 kgf/cm ² 3129 psi → 2987 psi
	Allowable limit	5 seconds 21.57 MPa → 20.59 MPa 220 kgf/cm ² → 210 kgf/cm ² 3129 psi → 2987 psi

(2) Injection Nozzle



- Be careful not to come into direct contact with the injected spray. The spray destroys any cells it touches. It may also cause blood poisoning, etc. Check the injection nozzle after confirming that nobody is standing in the direction of the spray.

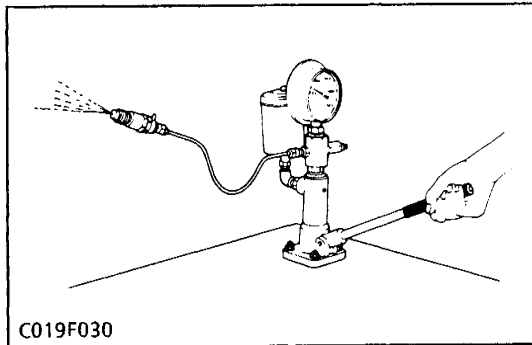

C019F030

Fuel Injection Pressure

1. Set the injection nozzle to the nozzle tester.
2. Measure the injection pressure.
3. If the measurement is not within the factory specifications, adjust with the adjusting washer inside the nozzle holder.

Fuel injection pressure	Factory spec.	13.73 to 14.71 MPa 140 to 150 kgf/cm ² 1991 to 2133 psi
-------------------------	---------------	--

(Reference)

- * Adjusting washer assembly: Code No. 15221-98101
- Pressure change per 0.1 mm (0.039 in.) adjusting washer:
Approx. 981kPa, 10 kgf/cm², 142 psi
- Thickness of adjusting washers:

1.00 mm (0.0394 in.) [Code No. 15221-98111]	1.35 mm (0.0531 in.) [Code No. 15221-98181]
1.05 mm (0.0413 in.) [Code No. 15221-98121]	1.40 mm (0.0551 in.) [Code No. 15221-98191]
1.10 mm (0.0433 in.) [Code No. 15221-98131]	1.45 mm (0.0571 in.) [Code No. 15221-98201]
1.15 mm (0.0453 in.) [Code No. 15221-98141]	1.50 mm (0.0591 in.) [Code No. 15221-98211]
1.20 mm (0.0472 in.) [Code No. 15221-98151]	1.55 mm (0.0610 in.) [Code No. 15221-98221]
1.25 mm (0.0492 in.) [Code No. 15221-98161]	1.60 mm (0.0630 in.) [Code No. 15221-98231]
1.30 mm (0.0512 in.) [Code No. 15221-98171]	1.65 mm (0.0650 in.) [Code No. 15221-98241]
	1.70 mm (0.0669 in.) [Code No. 15221-98251]
	1.75 mm (0.0689 in.) [Code No. 15221-98261]
	1.80 mm (0.0709 in.) [Code No. 15221-98271]
	1.85 mm (0.0728 in.) [Code No. 15221-98281]
	1.90 mm (0.0748 in.) [Code No. 15221-98291]
	1.95 mm (0.0768 in.) [Code No. 15221-98301]

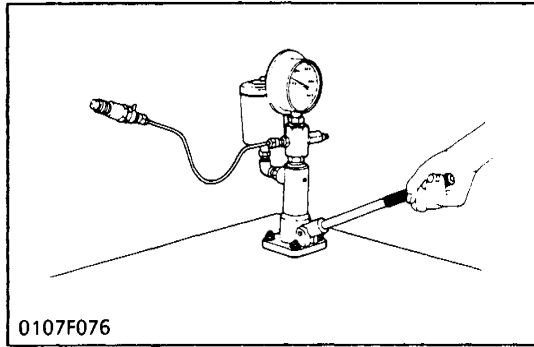

Fuel Tightness of Nozzle Valve Seat

1. Apply a pressure 12.75 MPa (130 kgf/cm², 1849 psi).
2. After keeping the nozzle under this pressure for 10 seconds, check to see if fuel leaks from the nozzle valve seat.
3. If fuel should leak, replace the nozzle piece.

Fuel tightness of nozzle valve seat	Factory spec.	When the pressure is 12.75 MPa (130 kgf/cm ² , 1849 psi), the valve seat must be fuel tightness
-------------------------------------	---------------	--

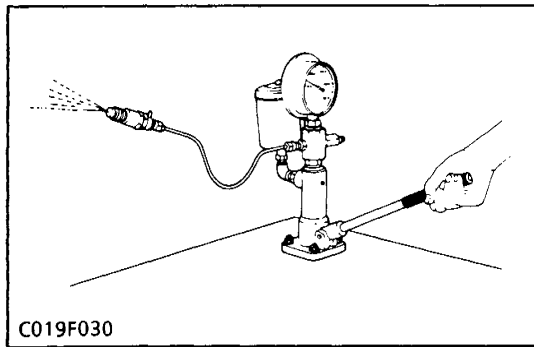

Nozzle Spraying Condition

1. Set the nozzle to a nozzle tester and check the nozzle spraying condition.
2. If the spraying condition is defective, replace the nozzle piece.

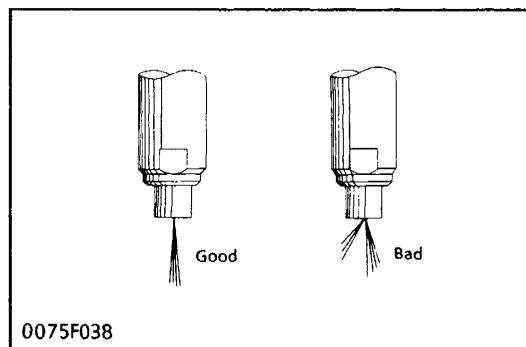

DISASSEMBLING AND ASSEMBLING

(1) Injection Nozzle

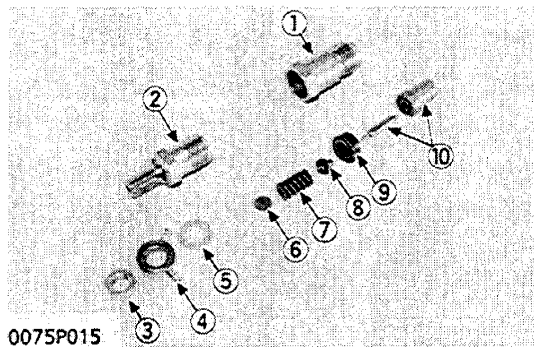

- | | |
|------------------------|----------------------|
| (1) Nozzle Nut | (6) Adjusting Washer |
| (2) Nozzle Holder Body | (7) Nozzle Spring |
| (3) Nut | (8) Push Rod |
| (4) Eye Joint | (9) Distance Piece |
| (5) Plain Washer | (10) Nozzle Piece |

Nozzle Holder

1. Secure the nozzle nut (1) with a vise.
2. Remove the nut (3) and remove the eye joint (4) and the plain washer (5).
3. Remove the nozzle holder body (2), and take out parts inside.

(When reassembling)

- Assemble the nozzle in clean light oil.
- Install the push rod (8), noting its direction.

Tightening torque	Nozzle holder body to nozzle nut	58.8 to 78.4 N·m 6.0 to 8.0 kgf·m 43.4 to 57.8 ft-lbs
	Nozzle holder assembly to cylinder head	29.4 to 49.0 N·m 3.0 to 5.0 kgf·m 21.7 to 36.2 ft-lbs

■ IMPORTANT

- Since the nozzle piece is precision finished, a piece of wood must be used to remove carbon deposit. Do not use pieces of metal.
- After assembling the nozzle, be sure to adjust the fuel injection pressure (See page S.1-48).

CONTENTS

TROUBLESHOOTING	S.2-1
SERVICING SPECIFICATIONS	S.2-2
1. Single Plate Clutch	S.2-2
2. Dual Stage Clutch (B2150)	S.2-3
TIGHTENING TORQUES	S.2-3
CHECKING, DISASSEMBLING AND SERVICING	S.2-4
[1] SINGLE PLATE CLUTCH	
(B1550-B1750-B1550HST-B1750HST-B2150HST)	
CHECKING AND ADJUSTING	S.2-4
DISASSEMBLING AND ASSEMBLING	S.2-6
SERVICING	S.2-7
[2] DUAL STAGE CLUTCH (B2150)	
CHECKING AND ADJUSTING	S.2-9
DISASSEMBLING AND ASSEMBLING	S.2-10
SERVICING	S.2-12

TROUBLESHOOTING

Symptom	Probable Cause	Solution	Reference Page
Clutch Drags	<ul style="list-style-type: none"> ● Clutch pedal play excessive ● Clutch disc boss splines sticking or rusted 	Adjust Replace or Remove rust Remove dust	S.2-4,9 — S.2-7,12
	<ul style="list-style-type: none"> ● Dust on clutch disc generated from clutch disc facing ● Grease or oil on clutch disc facing ● Clutch disc or pressure plate warped ● Pilot bearing sticking or worn ● Release lever improperly adjusted (B2150) 	Replace Replace Replace Adjust	S.2-7,10, 12 S.2-7,12,13 — S.2-12,13
Clutch Slips	<ul style="list-style-type: none"> ● Clutch pedal play too small ● Clutch disc excessively worn ● Grease or oil on clutch disc facing ● Clutch disc or pressure plate warped ● Diaphragm spring weaken or broken (Except B2150) ● Belleville spring weaken or broken (B2150) ● Release lever improperly adjusted (B2150) 	Adjust Replace Replace Replace Replace Replace Adjust	S.2-4,9 S.2-7,12 S.2-7,10,12 S.2-7,12,13 S.2-7 S.2-14 S.2-12,13
	<ul style="list-style-type: none"> ● Grease or oil on clutch disc facing ● Clutch disc or pressure plate warped ● Clutch disc boss splines worn, sticking or rusted ● Propeller shaft bent ● Pressure plate or flywheel face cracked or scored ● Clutch disc boss splines and propeller shaft splines worn ● Belleville spring strength uneven or broken (B2150) 	Replace Replace Replace or Remove rust Replace Replace Replace Replace	S.2-7,10,12 S.2-7,12,13 S.2-7,12 — S.2-7,13 S.2-7,12 S.2-14
Rattle During Running	<ul style="list-style-type: none"> ● Release bearing worn or sticking ● Pilot bearing worn or sticking 	Replace Replace	S.2-8,12 —
Clutch Squeaks	<ul style="list-style-type: none"> ● Release bearing sticking or dry 	Replace or Lubricate	S.2-8,12
	<ul style="list-style-type: none"> ● Pilot bearing worn or sticking ● Clutch disc excessively worn 	Replace Replace	— S.2-7,12
Vibration	<ul style="list-style-type: none"> ● Propeller shaft bent 	Replace	—
	<ul style="list-style-type: none"> ● Clutch disc rivet worn or broken 	Replace	S.2-7,12
	<ul style="list-style-type: none"> ● Clutch parts broken 	Replace	—

SERVICING SPECIFICATIONS

1 Single Plate Clutch (B1550-B1750-B1550HST-B1750HST-B2150HST)

Item		Factory Specification	Allowable Limit
Clutch Pedal	Free Play	20 to 30 mm 0.79 to 1.18 in.	—
Clutch Adjusting Screw	Distance (Except B2150HST)	11 to 13 mm 0.43 to 0.51 in.	—
	(B2150HST)	11 to 12 mm 0.43 to 0.47 in.	—
Safety Switch	Clearance (Except B2150HST)	4.5 to 5.0 mm 0.177 to 0.197 in.	—
	Distance (B2150HST)	10 to 12 mm 0.39 to 0.47 in.	—
Clutch Disc Spline Boss to Propeller Shaft	Backlash	—	2.0 mm 0.079 in.
Clutch Disc Surface to Rivet	Depth	—	0.3 mm 0.012 in.
Pressure Plate	Flatness	—	0.2 mm 0.008 in.

2 Dual Stage Clutch (B2150)

Item		Factory Specification	Allowable Limit
Clutch Pedal	Free Play	20 to 30 mm 0.79 to 1.18 in.	—
Adjusting Screw to Stopper	Clearance	16 to 17 mm 0.63 to 0.67 in.	—
Safety Switch	Distance	25 to 27 mm 0.98 to 1.06 in.	—
Pressure Plate 2 (PTO) to Adjusting screw	Clearance	1.4 to 1.5 mm 0.055 to 0.059 in.	—
Clutch Disc Boss to Proper Shaft (Traveling, PTO)	Backlash (Displacement Around Disc Edge)	—	2 mm 0.079 in.
Clutch Disc (Traveling, PTO)	Disc Facing Surface to Rivet Top (Depth)	—	0.3 mm 0.012 in.
Release Lever	Height	Less than 0.7 mm 0.028 in.	—
	Mutual Difference	Less than 0.2 mm 0.008 in.	—
Pressure Plate	Flatness	—	0.2 mm 0.008 in.
Belleville Spring	Free Height	7.24 mm 0.2850 in.	6.76 mm 0.2661 in.

TIGHTENING TORQUES

Tightening torques of screws and nuts on the table below are especially specified.
(For general use screws and nuts: See page S.G-4)

Item	N·m	kgf·m	ft-lbs
Clutch Mounting Screw	24 to 28	2.4 to 2.8	17.4 to 20.3
Adjusting Screw Lock Nut	15.7 to 21.6	1.6 to 2.2	11.6 to 15.9

CHECKING, DISASSEMBLING AND SERVICING

[1] SINGLE PLATE CLUTCH (B1550-B1750-B1550HST-B1750HST-B2150HST)

CHECKING AND ADJUSTING

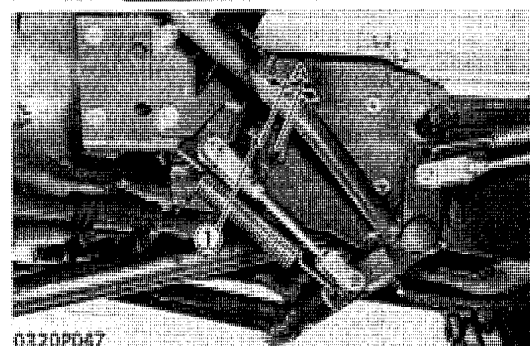
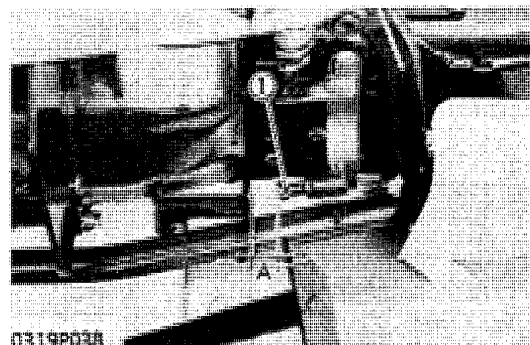
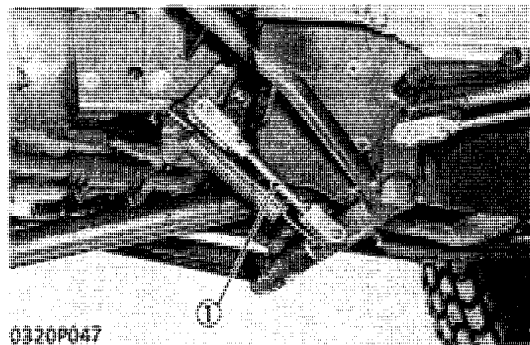
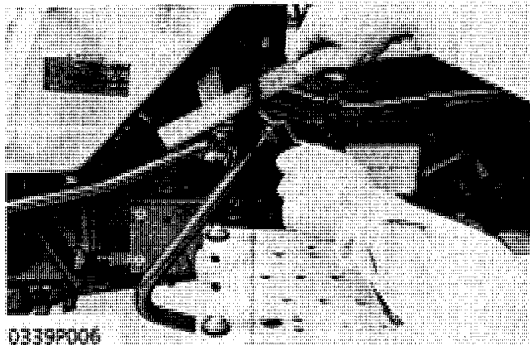

Clutch Pedal Play

1. Depress the clutch pedal by hand, and measure the amount of pedal movement.
2. If the measurement is not within the factory specifications, adjust the play by turning the rod (1).

Clutch pedal play	Factory spec.	20 to 30 mm 0.79 to 1.18 in.
-------------------	---------------	---------------------------------

(1) Rod

Clutch Pedal Traveling

1. Measure the distance "A".
2. If the measurement is not within the factory specifications, adjust it with the clutch adjusting screw (1).

NOTE

- After adjustment, secure the clutch adjusting screw with the lock nut.

■ B1550-B1750-B1550HST-B1750HST

Distance between clutch rod and clutch adjusting screw	Factory spec.	11 to 13 mm 0.43 to 0.51 in.
--	---------------	---------------------------------

■ B2150HST

Distance between clutch rod and clutch adjusting screw	Factory spec.	11 to 12 mm 0.43 to 0.47 in.
--	---------------	---------------------------------

(1) Clutch Adjusting Screw

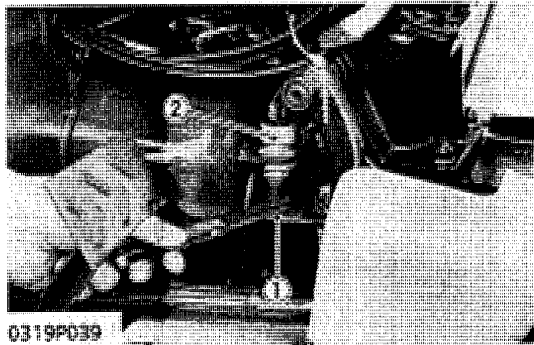

0319P039

Clearance between Safety Switch and Clutch Rod

(B1550-B1750-B1550HST-B1750HST)

1. Measure the clearance between safety switch and clutch rod with a feeler gauge.
2. If the clearance is not within the factory specifications, adjust the mounting position of switch.

Clearance between safety switch and clutch rod	Factory spec.	4.5 to 5.0 mm 0.177 to 0.197 in.
--	---------------	-------------------------------------

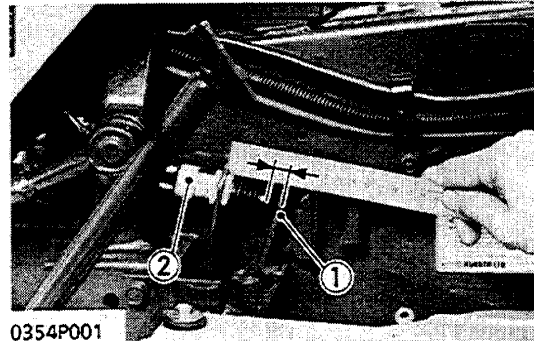

0354P001

Safety Switch Setting Position (B2150HST)

1. Measure the distance between the clutch rod plate (1) and the tip of the safety switch (2).
2. If the measurement is not within the factory specifications, adjust it with the mounting nut.

Distance between tip of safety switch and clutch rod plate	Factory spec.	10 to 12 mm 0.39 to 0.47 in.
--	---------------	---------------------------------

(1) Clutch Rod Plate

(2) Safety Switch

DISASSEMBLING AND ASSEMBLING

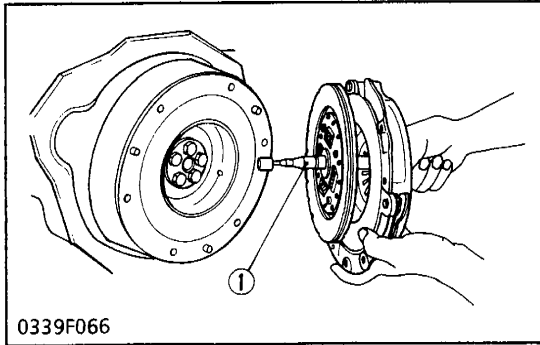

(1) Clutch Center Tool

Separation of Clutch Assembly

1. Separate the clutch assembly from the flywheel.

(When reassembling)

- Install the clutch assembly with the clutch center tool (Code No.: 07916-51050).
- Face the longer end of the clutch disc boss (2) rearward.

Tightening torque	Clutch mounting screw	24 to 28 N·m 2.4 to 2.8 kgf·m 17.4 to 20.3 ft·lbs
-------------------	-----------------------	---

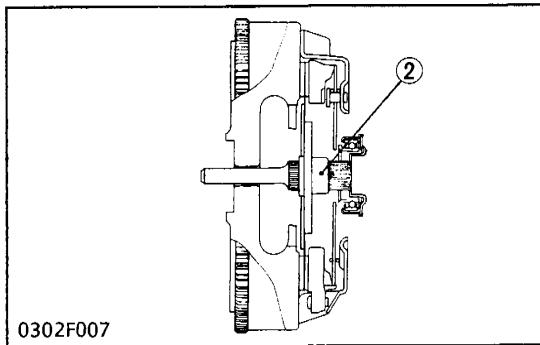

(2) Clutch Disc Boss

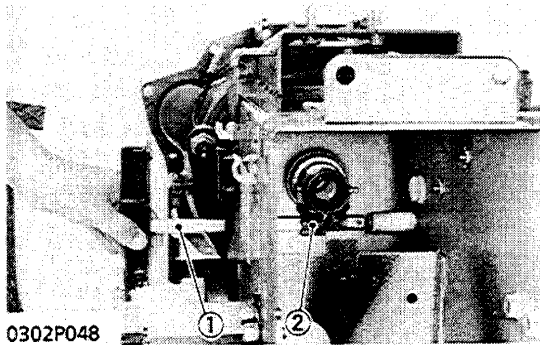

(1) Clutch Rod

(2) Clutch Release Fork

Clutch Rod and Clutch Release Fork

1. Remove the front step frame LH.
2. Remove the cotter pin at the end of the clutch rod, and remove the clutch release fork (2) and clutch rod (1).

(When reassembling)

- Set the fork in the correct direction.

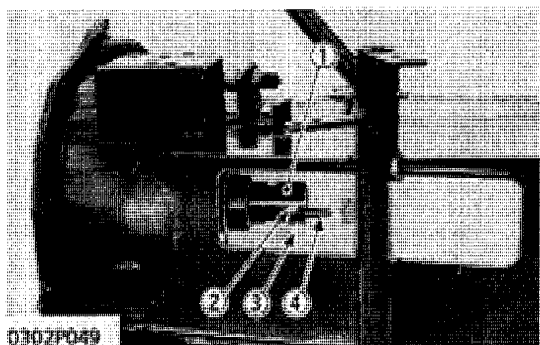

(1) Release Bearing Holder

(3) Grease Nipple

(2) Spring Mounting Screw

(4) Spring

Release Bearing Holder

1. Remove the spring mounting screw (2) and spring (4).
2. Remove the grease nipple (3).
3. Pull out the release bearing holder (1) toward the front of the housing.

SERVICING

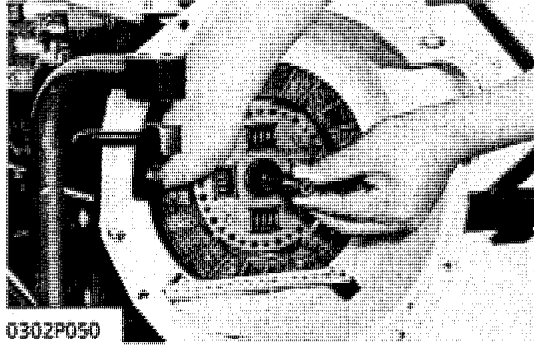

0302P050

Backlash between Clutch Disc and Propeller Shaft

1. Mount the clutch disc onto the propeller shaft.
2. Fix the rule on the housing.
3. Hold the propeller shaft so that it does not rotate.
4. Slightly move the disc and measure the displacement around disc edge.
5. If the measurement exceeds the allowable limit, replace clutch disc.

Displacement around disc edge	Allowable limit	2.0 mm 0.079 in.
-------------------------------	-----------------	---------------------

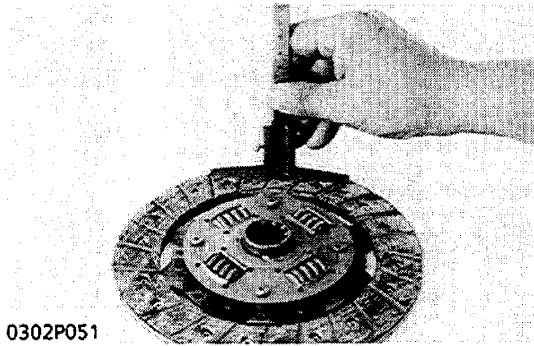

0302P051

Clutch Disc Wear

1. Measure the depth from clutch disc surface to the top of rivet at least 10 points with a depth gauge.
2. If the depth is less than the allowable limit, replace.
3. If oil is sticking to the clutch disc, or disc surface is carbonized, replace clutch disc.

Depth to rivet top	Allowable limit	0.3 mm 0.012 in.
--------------------	-----------------	---------------------

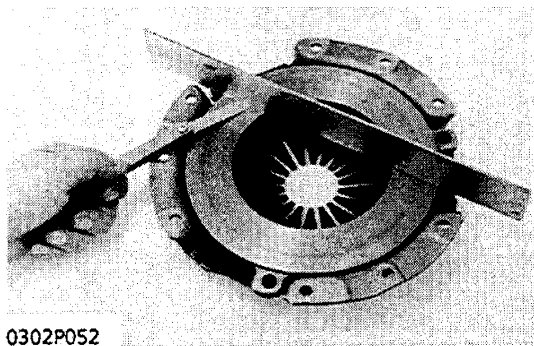

0302P052

Pressure Plate Flatness

1. Place a straightedge on the pressure plate and measure clearance with a feeler gauge at several points.
2. If the clearance exceeds allowable limit, replace pressure plate.
3. When the pressure plate is worn around its outside and its inside surface only is in contact with the straightedge, replace it even if the clearance is within the allowable limit.

Clearance between pressure plate and straight edge	Allowable limit	0.2 mm 0.008 in.
--	-----------------	---------------------

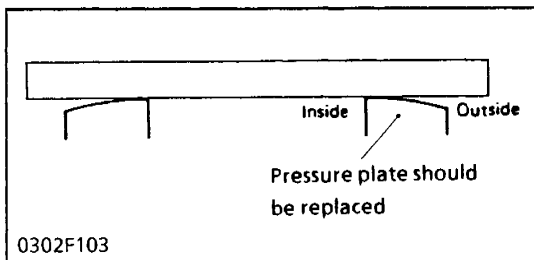

0302F103

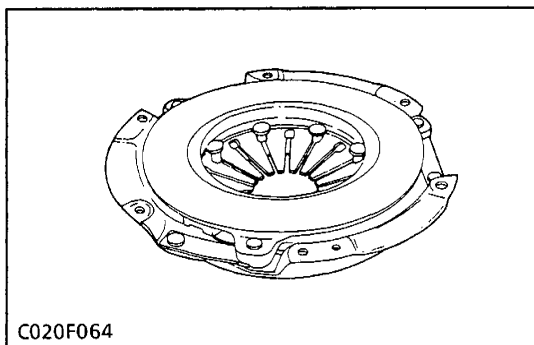

C020F064

Checking Pressure Plate and Diaphragm

1. Check the pressure plate and if scratched on its surface, correct with sandpaper or replace it.
2. Check the diaphragm for cracks and scratches. If defects are found, replace it.

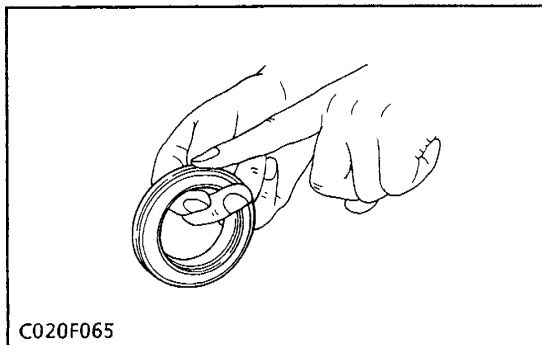

Checking Clutch Release Bearing

1. Check the clutch release bearing. If surface is worn excessively, or abnormal sounds occur, replace it.

[2] DUAL STAGE CLUTCH (B2150)

CHECKING AND ADJUSTING

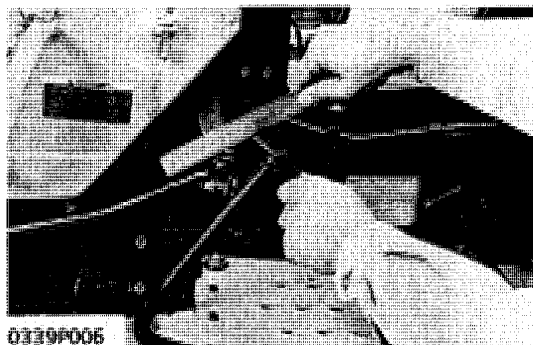

Clutch Pedal Play

1. Depress the clutch pedal by hand, and measure the amount of pedal movement.
2. If the measurement is not within the factory specifications, adjust the play by turning the rod (1).

Clutch pedal play	Factory spec.	20 to 30 mm 0.79 to 1.18 in.
-------------------	---------------	---------------------------------

(1) Rod

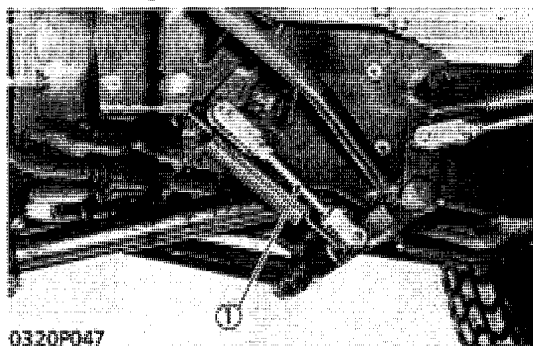

Clutch Pedal Traveling

1. Measure the distance "A".
2. If the measurement is not within the factory specifications, adjust it with the clutch adjusting screw (1).

NOTE

- After adjustment, secure the clutch adjusting screw with the lock nut.

Distance between adjusting screw and stopper	Factory spec.	16 to 17 mm 0.63 to 0.67 in.
--	---------------	---------------------------------

(1) Clutch Adjusting Screw

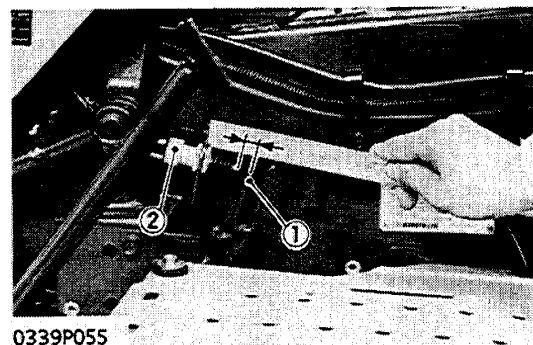
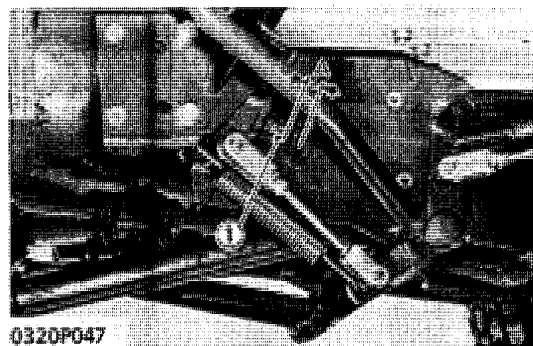

Safety Switch Setting Length

1. Measure the distance between the clutch rod plate (1) and the tip of the safety switch (2).
2. If the measurement is not within the factory specifications, adjust with the mounting nut.

Distance between clutch rod plate and tip of safety switch	Factory spec.	25 to 27 mm 0.98 to 1.06 in.
--	---------------	---------------------------------

(1) Clutch Rod Plate

(2) Safety Switch

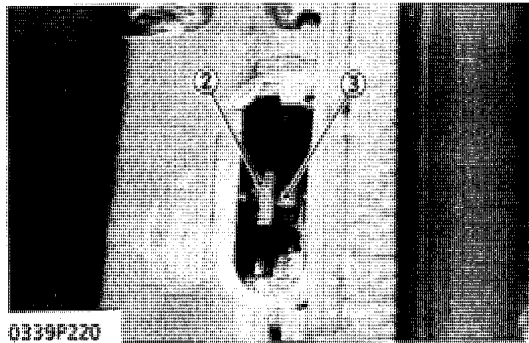
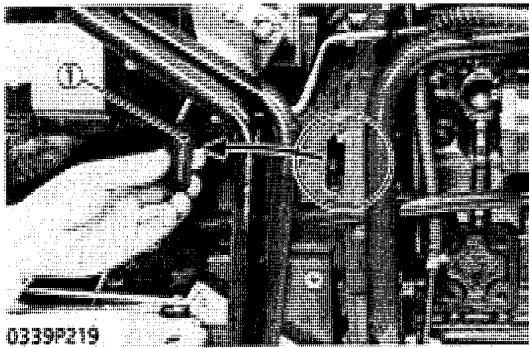

Clearance between Pressure Plate 2 and Adjusting Screw

1. Remove the cover (1) located on the right side of flywheel housing case.
2. Loosen the lock nut (2), turn the adjusting screw (3) by using 6 mm (0.24 in.) wrench until head of the screw contacts pressure plate slightly.
Make 3/4 turn counterclockwise to give the clearance of factory specification.
3. Tighten the lock nut, holding the adjusting screw.

Clearance between pressure plate 2 and adjusting screw	Factory spec.	1.4 to 1.5 mm 0.055 to 0.059 in
Tightening torque	Adjusting screw lock nut	15.7 to 21.6 N·m 1.6 to 2.2 kgf·m 11.6 to 15.9 ft-lbs

(1) Cover
(2) Lock Nut

(3) Adjusting Screw

DISASSEMBLING AND ASSEMBLING

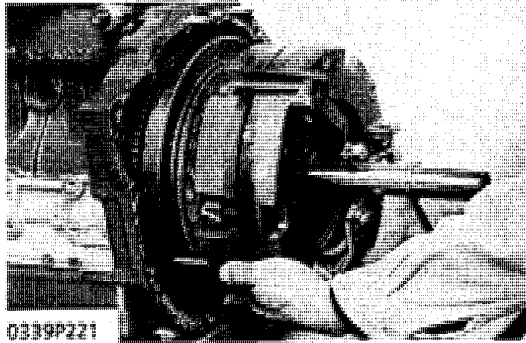

Removing Clutch

1. Insert the clutch center bar (Included in the clutch centeriser kit, Code No. : 07916-90052) with the guide (Code No. : 07916-53471).
2. Remove the mounting screws.
3. Remove the clutch assembly with the clutch center bar.

(When reassembling)

IMPORTANT

- Be sure to align the center of disc (Travelling) and flywheel by inserting the clutch center tool (Included in the clutch centeriser kit, Code No. : 07916-90052) with the guide (Code No. : 07916-53471).

Tightening torque	Clutch mounting screw	23.5 to 27.5 N·m 2.4 to 2.8 kgf·m 17.4 to 20.3 ft-lbs
-------------------	-----------------------	---

NOTE

- Do not allow grease and oil on the clutch disc facing.

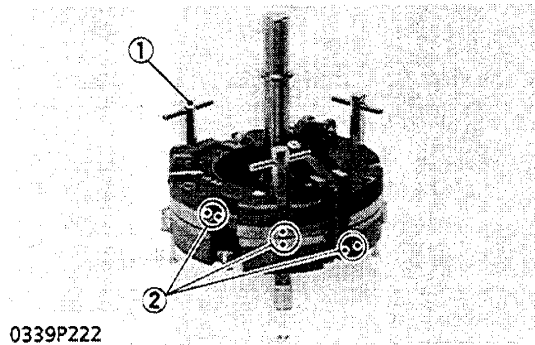

0339P222

Mounting to Clutch Table

1. Mount the clutch on the clutch table (included in the clutch centeriser kit, Code No. : 07916-90052). with the clutch center bar.
2. Put parting marks (2) on the clutch cover and pressure plate as shown in the figure.
3. Tighten evenly the clamping bolt (1) (included in the clutch centeriser kit, Code No.: 07916-90052).

(1) Clamping Bolt

(2) Parting Mark

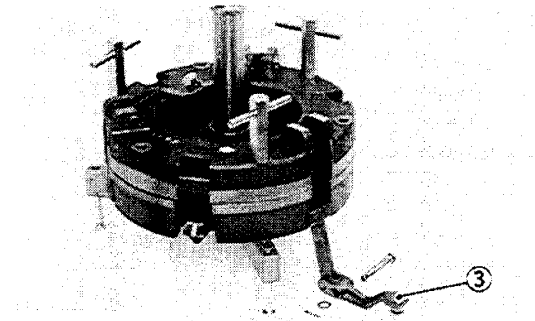

0339P223

Disassembling Clutch Assembly

1. Draw out the joint pins and disconnect the release levers (3).
2. Loosen the three clamping bolts evenly and remove them.
3. Remove the clutch cover (9), belleville spring (8), pressure plate (7), and clutch disc (6) in order.
4. Remove the clutch cover (5), belleville spring (4), and pressure plate (travelling) (2) in order.

(When reassembling)

IMPORTANT

- When assembling the clutch covers and pressure plates, be sure to align the parting marks to insure proper dynamic balance.

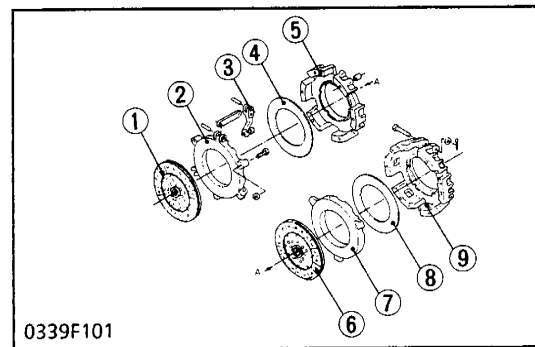

0339F101

- (1) Clutch Disc (Traveling)
- (2) Pressure Plate (Traveling)
- (3) Release Lever
- (4) Belleville Spring
- (5) Clutch Cover

- (6) Clutch Disc (PTO)
- (7) Pressure Plate (PTO)
- (8) Belleville Spring
- (9) Clutch Cover

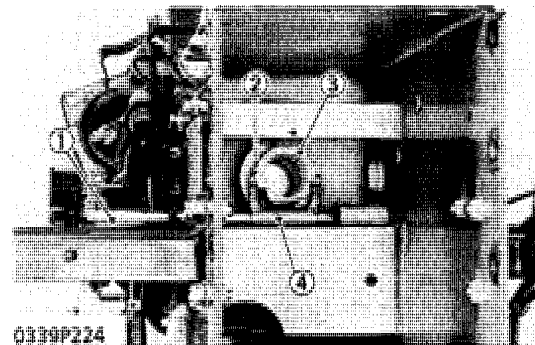

0339P224

Clutch Rod and Clutch Release Fork

1. Remove the cotter pin at end of clutch rod.
2. Draw out the clutch lever (1) to remove the release fork (4).
3. Remove the release spring and the bolt.
4. Remove the release bearing (3) and release hub as a unit.

(When reassembling)

- Make sure the direction of the release fork (4) is correct.
- Inject grease to the release hub (2).

- (1) Clutch Lever
- (2) Release Hub

- (3) Release Bearing
- (4) Release Fork

SERVICING

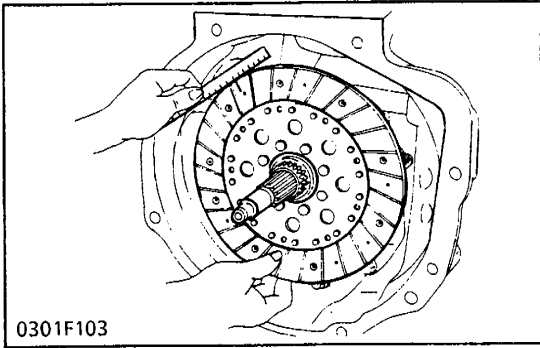

0301F103

Backlash between Clutch Disc Boss and Shaft

1. Mount the PTO clutch disc to the propeller shaft 2.
2. Hold the propeller shaft 2 so that it does not turn.
3. Rotate the disc lightly and measure the displacement around the disc edge.
4. If the movement exceeds the allowable limit, replace.

Displacement around disc edge (PTO)	Allowable limit	2 mm 0.079 in.
-------------------------------------	-----------------	-------------------

5. Perform measurement for the travelling clutch disc and the propeller shaft 1 in the same way as above.

Displacement around disc edge (travelling)	Allowable limit	2 mm 0.079 in.
--	-----------------	-------------------

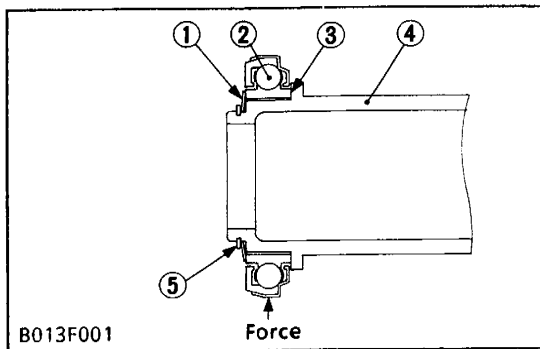

B013F001

- (1) Belleville Spring
- (2) Release Bearing
- (3) Shim
- (4) Release Hub
- (5) External Snap Ring

Release Bearing

1. Remove the belleville spring (1), release bearing (2) and shim (3) (if equipped) from the release hub (4) after taking off the external snap ring (5).
2. Check for an abnormal wear on the contact surface of it.
3. Hold the bearing inner race and rotate the outer race, while applying pressure to it.
4. If the bearing rotation is rough or noisy, replace it.

(When reassembling)

- Set the belleville spring in the correct direction.
- Set the release bearing so that the working force of it is 78 to 118 N (8 to 12 kgf, 18 to 26 lbs) in the radial direction by adjusting with the shim (thickness: 0.2 mm, 0.079 in.)

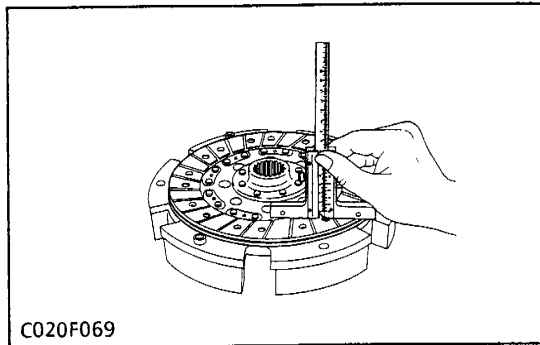

C020F069

Clutch Disc Wear

1. Measure the depth from the travelling clutch disc surface to the top of rivet at least 10 points with a depth gauge.
2. If the depth is less than allowable limit, replace it.
3. If oil is sticking to clutch disc, or disc surface is carbonized, replace it.
In this case, inspect transmission main shaft oil seal, engine rear oil seal and other points for oil leakage.
4. Check the same at the PTO clutch disc as travelling clutch disc.

Depth to rivet top (travelling clutch disc and PTO clutch disc)	Allowable limit	0.3 mm 0.012 in.
---	-----------------	---------------------

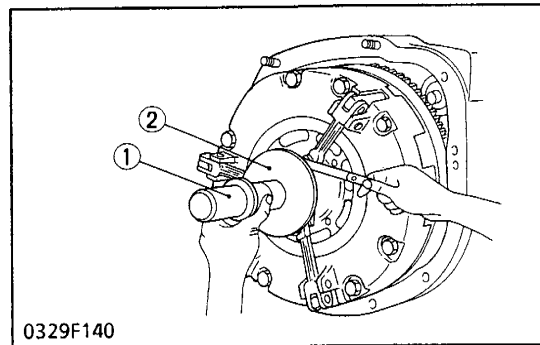

0329F140

Mutual Difference of Release Lever

1. Insert the clutch center bar (1) and gauge ring (2) (Included in the clutch centeriser kit, Code No. : 07916-90052) with the guide (Code No. : 07916-53471).
2. Measure the clearance between gauge ring and the top of adjusting screw with a feeler gauge.
3. If the clearance is not within the factory specifications, adjust with the adjusting screws.

Mutual difference of release lever	Factory spec.	0.0 to 0.2 mm 0.000 to 0.008 in.
------------------------------------	---------------	-------------------------------------

(1) Clutch Center Bar

(2) Gauge Ring

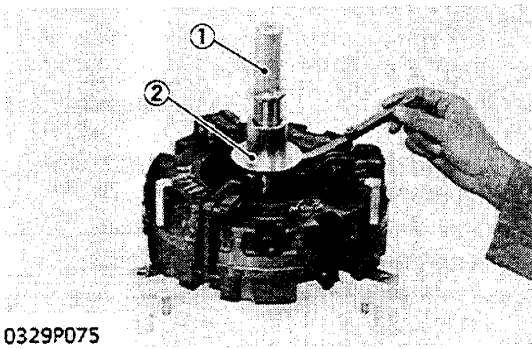

0329P075

(1) Clutch Center Bar (2) Gauge Ring

Release Lever Height

1. Mount the clutch on the clutch table (Included in the clutch centeriser kit, Code No. : 07916-90052) with the clutch center bar (1) and gauge ring (2).
2. Adjust the height of the three release levers with the gauge ring as shown in Photo. 0329P075.
- * Use 32 mm side of the gauge ring for B9200DC.
3. Measure the clearance between the gauge ring and the top of adjusting screw with a feeler gauge.
4. If the clearance is not within the factory specifications, adjust with the adjusting screws.

Clearance between gauge ring and the top of adjusting screw	Factory spec.	0.0 to 0.7 mm 0.000 to 0.028 in.
Tightening torque	Adjusting screw lock nut	14.7 to 19.6 N·m 1.5 to 2.0 kgf·m 10.8 to 14.5 ft-lbs

IMPORTANT

- Be sure to adjust the mutual difference of release lever to within the factory specifications.

NOTE

- Apply adhesive (Cemedine No. 110 by Cemedine Industry Co., Ltd. or equivalent) to the adjusting screws, replace lever and lock nuts.

Clearance between Pressure Plate 2 and Adjusting Screw

1. Measure the clearance between pressure plate 2 and top of adjusting screw with a feeler gauge.
2. If the clearance is not within the factory specifications, rotate adjusting screw to adjust.

Clearance between pressure plate 2 and adjusting screw	Factory spec.	1.4 to 1.5 mm 0.055 to 0.059 in.
Tightening torque	Adjusting screw lock nut	15.7 to 21.6 N·m 1.6 to 2.2 kgf·m 11.6 to 15.9 ft-lbs

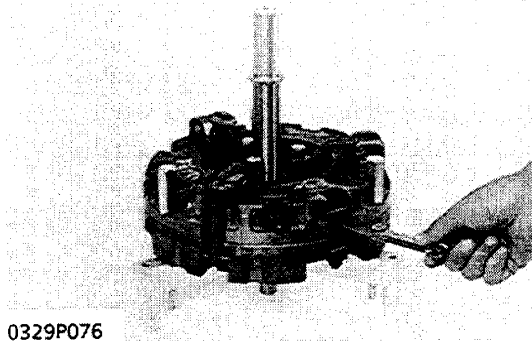

0329P076

Pressure Plate Flatness

1. Place a straightedge on the pressure plate, and measure the clearance with a feeler gauge at several points.
2. If the clearance exceeds the allowable limit, replace.
3. When the pressure plate is worn around its outside and its inside surface only is in contact with the straightedge, replace even if the clearance is within the allowable limit.

Clearance between pressure plate and straightedge	Allowable limit	0.2 mm 0.008 in.
---	-----------------	---------------------

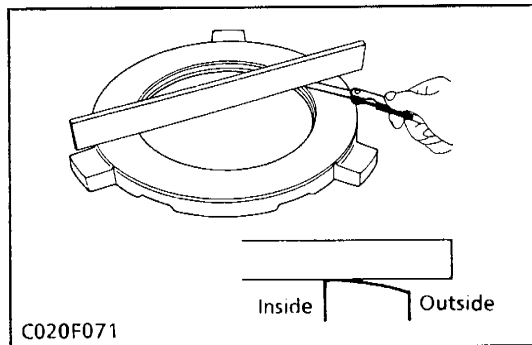

C020F071

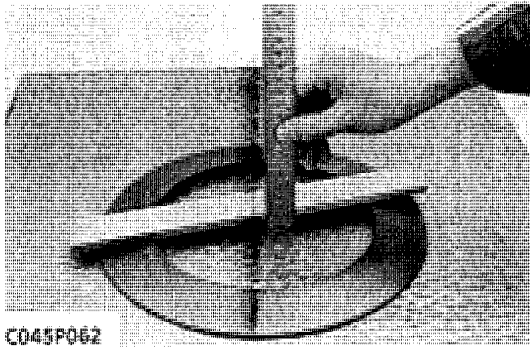

Belleville Spring Free Height

1. Put the belleville spring on the surface plate.
2. Place a straightedge on the belleville spring and measure the free height.
3. If the measurement is less than the allowable limit, replace.
4. Check for cracks, if defects are found, replace.

Belleville spring free height	Factory spec.	7.24 mm 0.2850 in.
	Allowable limit	6.76 mm 0.2661 in.

CONTENTS

[B1550-B1750-B1550HST-B1750HST]

TROUBLESHOOTING	S.3-1
SERVICING SPECIFICATIONS	S.3-4
TIGHTENING TORQUES	S.3-8
CHECKING, DISASSEMBLING AND SERVICING	S.3-9
[1] SPEED SET DEVICE (B1550HST-B1750HST)	
DISASSEMBLING AND ASSEMBLING.....	S.3-9
[2] HYDROSTATIC TRANSMISSION (B1550HST-B1750HST)	
CHECKING AND ADJUSTING	S.3-10
DISASSEMBLING AND ASSEMBLING.....	S.3-15
SERVICING	S.3-19
[3] TRANSMISSION CASE (B1550HST-B1750HST)	
DISASSEMBLING AND ASSEMBLING.....	S.3-28
[4] TRANSMISSION CASE (B1550-B1750)	
DISASSEMBLING AND ASSEMBLING.....	S.3-32
SERVICING	S.3-36
[5] DIFFERENTIAL GEAR CASE	
DISASSEMBLING AND ASSEMBLING.....	S.3-38
SERVICING	S.3-39

[B2150-B2150HST]

TROUBLESHOOTING	S.3-41
SERVICING SPECIFICATIONS	S.3-43
TIGHTENING TORQUES	S.3-47
CHECKING, DISASSEMBLING AND SERVICING	S.3-48
[1] SPEED SET DEVICE (B2150HST)	
DISASSEMBLING AND ASSEMBLING.....	S.3-48
[2] HYDROSTATIC TRANSMISSION (B2150HST)	
CHECKING AND ADJUSTING	S.3-48
DISASSEMBLING AND ASSEMBLING.....	S.3-52
SERVICING	S.3-54
[3] TRANSMISSION CASE (B2150HST)	
DISASSEMBLING AND ASSEMBLING.....	S.3-58
[4] DIFFERENTIAL GEAR CASE (B2150HST)	
DISASSEMBLING AND ASSEMBLING.....	S.3-60
[5] TRANSMISSION CASE (B2150)	
DISASSEMBLING AND ASSEMBLING.....	S.3-62
[6] DIFFERENTIAL GEAR CASE (B2150)	
DISASSEMBLING AND ASSEMBLING.....	S.3-65
[7] TRANSMISSION CASE AND DIFFERENTIAL GEAR CASE	
SERVICING	S.3-67

[B1550-B1750-B1550HST-B1750HST] TROUBLESHOOTING

■ HYDROSTATIC TRANSMISSION [B1550HST-B1750HST]

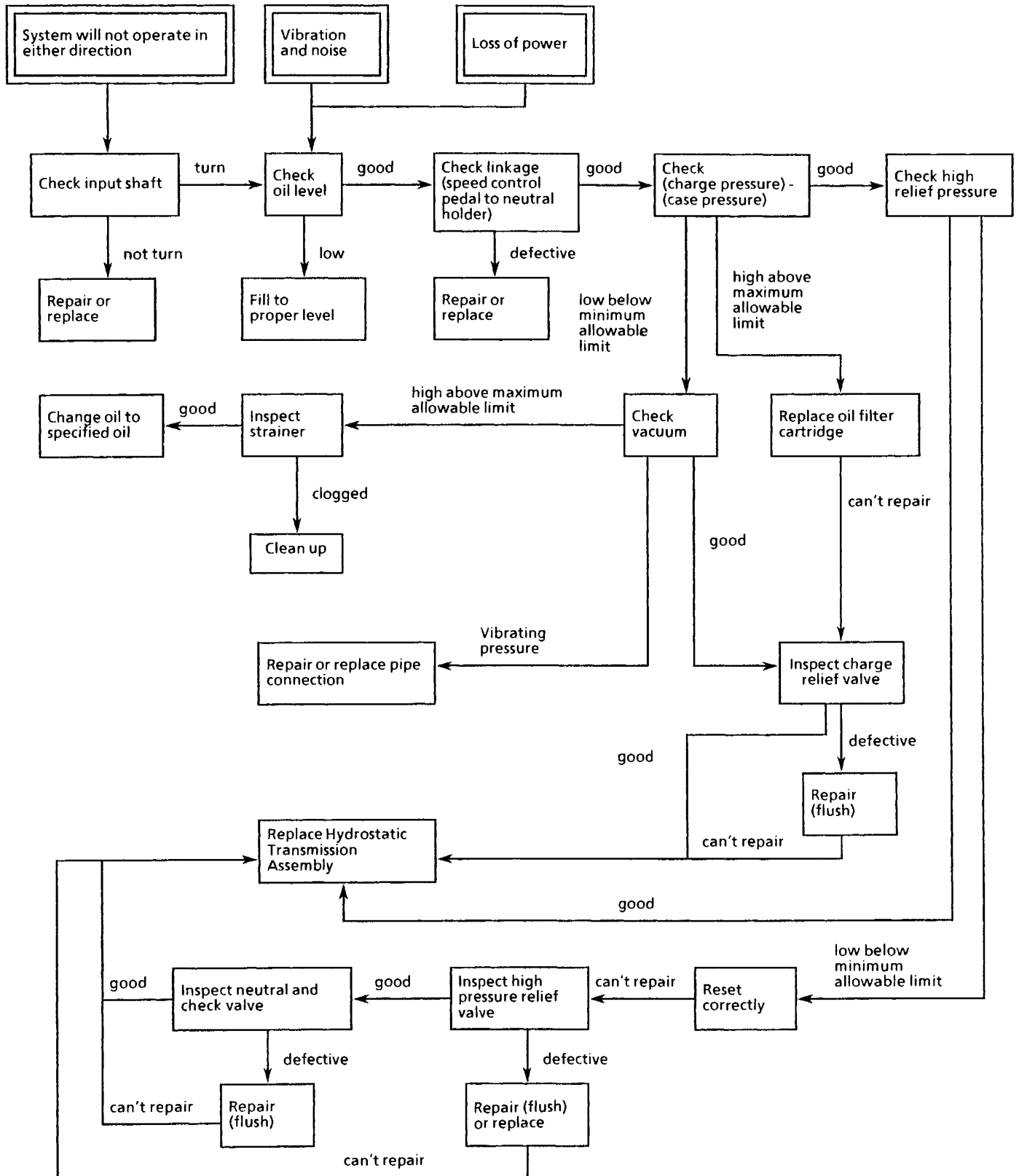

TROUBLESHOOTING (Continued)

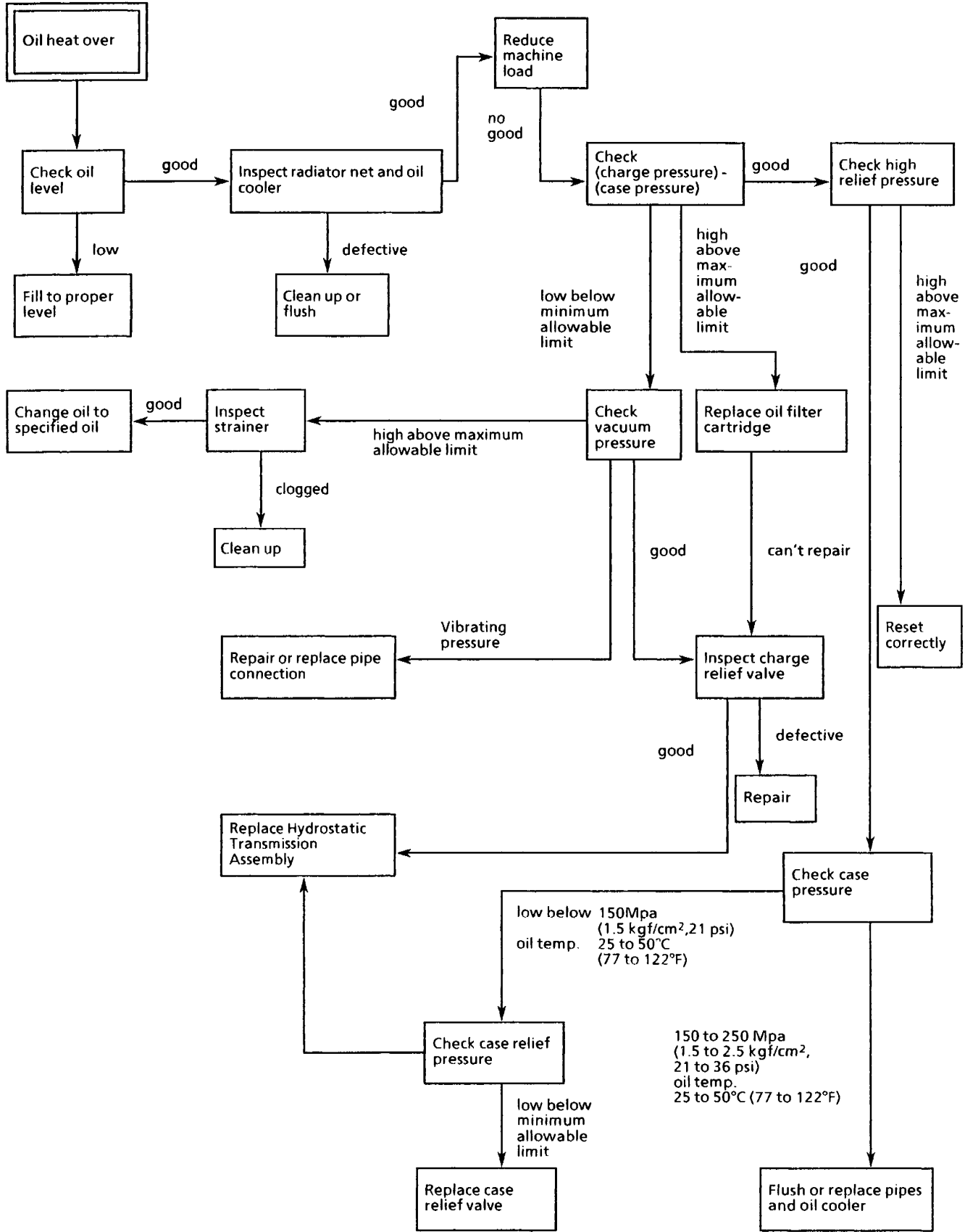

TROUBLESHOOTING (Continued)

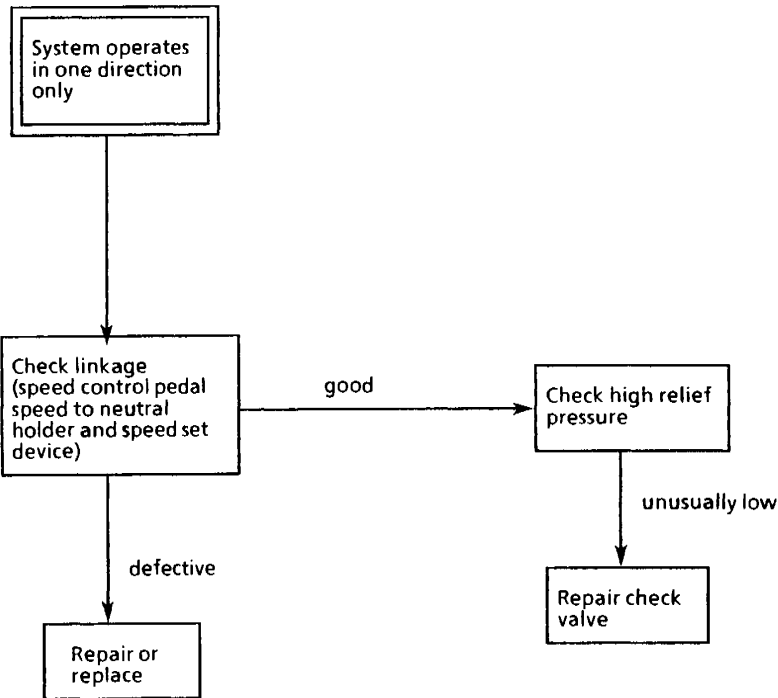
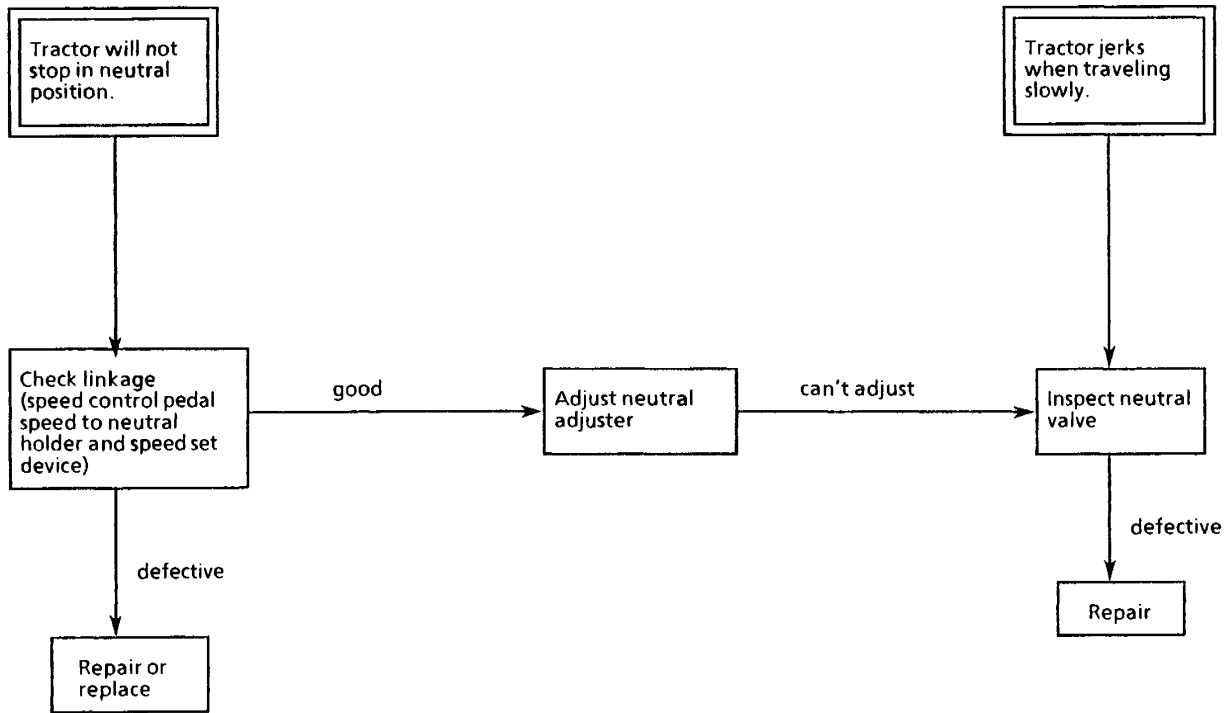

TROUBLESHOOTING

MECHANICAL TRANSMISSION [B1550-B1750]

Symptom	Probable Cause	Solution	Reference Page
Noise from Transmission	<ul style="list-style-type: none"> ● Transmission oil insufficient ● Gear worn or broken ● Improper backlash between ring gear and spiral bevel pinion shaft ● Improper backlash between differential pinion and differential side gear ● Bearings worn 	Refill Replace Adjust Adjust Replace	S.G-3 S.3-40 S.4-5 S.3-39
Gear Slip out of Mesh	<ul style="list-style-type: none"> ● Shift fork spring tension insufficient ● Shift fork or shifter worn ● Shift fork bent 	Replace Replace Replace	— S.3-33 S.3-33
Differential Lock Cannot Be Set	<ul style="list-style-type: none"> ● Differential lock pedal play excessive ● Differential lock shift fork broken ● Differential lock clutch broken 	Adjust Replace Replace	S.4-3 S.4-6 S.4-6
Differential Lock Pedal Does Not Return	<ul style="list-style-type: none"> ● Differential lock spring broken or fall ● Differential lock spring tension insufficient 	Replace or Assemble Replace	S.4-6 S.4-6

SERVICING SPECIFICATIONS

Item		Factory Specification	Allowable Limit
Speed Set Lever	Force (See page S.3-9)	29.4 to 34.3 N 3.0 to 3.5 kgf 6.6 to 7.7 lbs.	—
High Relief Valve	Setting Pressure	22.6 to 24.5 Mpa 230 to 250 kgf/cm ² 3271 to 3555 psi (Oil temperature at 25° to 50°C 77° to 122°F)	21.6 or 25.5 Mpa 220 or 260 kgf/cm ² 3128 or 3697 psi (Oil temperature at 25° to 50°C 77° to 122°F)
High Relief Valve Spring	Free Length Setting Length	40.0 mm 1.575 in. 34.0 mm 1.339 in. (load 612 N, 62.4 kgf, 138 lbs) 32.5 mm 1.280 in. (load 612 N, 62.4 kgf, 138 lbs)	— — —
Case Relief Valve	Setting Pressure	167 to 226 kPa 1.7 to 2.3 kgf/cm ² 24 to 33 psi (Oil temperature at 25° to 50°C 77° to 122°F)	147 or 245 kPa 1.5 or 2.5 kgf/cm ² 21 or 36 psi (Oil temperature at 25° to 50°C 77° to 122°F)
Case Relief Valve Spring	Free Length	25.92 mm 1.022 in.	—

SERVICING SPECIFICATIONS (Continued)

Item		Factory Specification	Allowable Limit
Case Relief Valve Spring	Setting Length	20.0 mm 0.787 in. (load 29.4 N 3.00 kgf 6.62 lbs)	—
		17.5 mm 0.689 in. (load 41.8 N 4.26 kgf 9.39 lbs)	—
Charge Relief Valve	Setting Pressure	441 to 579 kPa 4.5 to 5.9 kgf/cm ² 64 to 84 psi more than case pressure (Oil temperature at 25°C, 77°F)	412 or 608 kPa 4.2 or 6.2 kgf/cm ² 60 or 88 psi more than case pressure (Oil temperature at 25°C, 77°F)
		422 to 559 kPa 4.3 to 5.7 kgf/cm ² 61 to 81 psi more than case pressure (Oil temperature at 50°C, 122°F)	392 or 558 kPa 4.0 or 6.0 kgf/cm ² 57 or 85 psi more than case pressure (Oil temperature at 50°C, 122°F)
Vacuum	Setting Pressure	120 mmHg (Oil temperature at 25°C, 77°F)	—
		60 mmHg (Oil temperature at 50°C, 122°F)	—
		35 mmHg (Oil temperature at 80°C, 176°F)	220 mmHg (Oil temperature at 80°C, 176°F)
Neutral Valve Spring (short)	Free Length	19.71 mm 0.7770 in.	—
	Setting Length	15.0 mm 0.591 in. (load 27 N 2.7 kgf 6.0 lbs)	—
		11.0 mm 0.43 in. (load 49.0 N 5.0 kgf 11 lbs)	—

SERVICING SPECIFICATIONS (Continued)

Item		Factory Specification	Allowable Limit
Neutral Valve Spring (long)	Free Length	29.7 mm 1.169 in.	—
	Setting Length	15.0 mm 0.591 in. (load 17 N 1.7 kgf 3.7 lbs)	—
		11.0 mm 0.43 in. (load 21.18 N 2.16 kgf 4.76 lbs)	—
Check Valve Spring	Free Length	26.91 mm 1.183 in.	—
	Setting Length	19.5 mm 0.768 in. (load 3.128 N 0.319 kgf 0.763 lbs)	—
		16.2 mm 0.638 in. (load 4.51 N 0.460 kgf 1.014 lbs)	—
Piston to Bore	Clearance	0.02 mm 0.0008 in.	0.04 mm 0.0016 in.
Slipper	Thickness	3.00 mm 0.118 in.	2.90 mm 0.114 in.

SERVICING SPECIFICATIONS (Continued)

Item		Factory Specification	Allowable Limit
Gears	Backlash	0.10 to 0.20 mm 0.004 to 0.008 in.	0.4 mm 0.016 in.
Gear to Spline	Clearance	0.03 to 0.08 mm 0.0012 to 0.0031 in.	0.20 mm 0.0079 in.
① Sift Fork to Shift Gear Groove (B1550HST, B1750HST)	Clearance	0.10 to 0.35 mm 0.004 to 0.014 in.	0.50 mm 0.020 in.
29T-14T-18T Gear to 2nd Shaft (B1550HST, B1750HST) 2nd Shaft	Clearance O.D.	0.007 to 0.053 mm 0.0003 to 0.0021 in. 21.987 to 22.000 mm 0.8656 to 0.8661 in.	0.10 mm 0.0039 in. —
29T- 14T-18T Gear	I.D.	28.007 to 28.028 mm 1.1026 to 1.1035 in.	—
Needle	O.D.	2.994 to 3.000 mm 0.1179 to 0.1181 in.	—
② 16T-20T Gear to Reverse Shaft (B1550, B1750) Reverse Shaft	Clearance O.D.	0.07 to 0.045 mm 0.0003 to 0.0018 in. 21.967 to 21.980 mm 0.8648 to 0.8654 in.	0.10 mm 0.0039 in.
16T-20T Gear	I.D.	25.987 to 26.000 mm 1.0231 to 1.0236 in.	—
Needle	O.D.	1.994 to 2.000 mm 0.0785 to 0.0787 in.	—
17T, 21T Gear to 3rd Shaft (B1550HST, B1750HST) 3rd Shaft	Clearance O.D.	0.007 to 0.047 mm 0.0003 to 0.0019 in. 24.987 to 25.000 mm 0.9837 to 0.9842 in.	0.10 mm 0.0039 in. —
17T, 21T Gear	I.D.	29.007 to 29.028 mm 1.1420 to 1.1428 in.	—
Needle	O.D.	1.997 to 2.000 mm 0.0786 to 0.0787 in.	—
PTO Shaft	Initial Turning Torque	0.49 to 1.47 N-m 0.05 to 0.15 kgf-m 0.36 to 1.08 ft-lbs	—
Adjusting Shim	Thickness	0.3 mm, 0.012 in. 0.4 mm, 0.016 in. 0.5 mm, 0.020 in.	— — —
Ring Gear to Spiral Bevel Pinion Shaft	Backlash	0.10 to 0.20 mm 0.004 to 0.008 in.	0.4 mm 0.016 in.
Adjusting Shim	Thickness	0.2 mm, 0.008 in. 0.3 mm, 0.012 in. 0.5 mm, 0.020 in.	— — —

TIGHTENING TORQUES

Item	N·m	kgf·m	ft-lbs
Neutral Adjuster	18.6 to 32.3	1.9 to 3.3	13.7 to 23.9
Trunnion Shaft Cover	2.0 to 2.5	0.20 to 0.26	1.45 to 1.83
Charge Pump	10.8 to 13.7	1.62 to 1.98	8.0 to 10.1
Motor Swashplate	15.7 to 20.6	1.6 to 2.1	12 to 15
Port-block	30.9 to 37.7	3.15 to 3.85	17 to 20
High Relief Valve Seat	23.5 to 29.4	2.4 to 3.0	17.4 to 21.7
High Relief Valve Cap Nut	58.8 to 68.6	6.0 to 7.0	43.4 to 50.6
Case Relief Valve Nut	1.67 to 2.26	0.17 to 0.23	1.23 to 1.66
Plug (Drain)	49.0 to 58.8	5.0 to 6.0	36.2 to 43.4
Plug (P1, P2)	19.6 to 24.5	2.0 to 2.5	14.5 to 18.1
Plug (P1, P2) PT 3/8	29.4 to 39.2	3.0 to 4.0	21.7 to 28.9
Plug Seat (P1, P2)	49.0 to 58.8	5.0 to 6.0	36.2 to 43.4
Plug (P3, P4, P5)	8.8 to 10.8	0.9 to 1.1	6.5 to 8.0
HST Case to Transmission Case	48.1 to 55.9	4.9 to 5.7	35.4 to 41.2
Mid PTO Case Bearing Holder	13.7 to 19.6	1.4 to 2.0	10.1 to 14.5
Case Cover to Case			
Mid PTO Case to Transmission Case	48.1 to 55.9	4.9 to 5.7	35.4 to 41.2
Rear Cover Mounting Screw	39.2 to 64.7	4.0 to 6.6	28.9 to 47.7
PTO Shaft Screw	18.6 to 32.4	1.9 to 3.3	13.7 to 23.9

■ NOTE

- The hydrostatic transmission for the tractors from the serial number written below is explained on page **BM.3-1 to BM.3-11** and **BS.3-1 to BS.3-17**.

Models	Serial number
B1550HST (2WD)	above 20001
B1550HST (4WD)	above 60001
B1750HST (2WD)	above 20001
B1750HST (4WD)	above 60001

CHECKING, DISASSEMBLING AND SERVICING

[1] SPEED SET DEVICE (B1550HST-B1750HST)

DISASSEMBLING AND ASSEMBLING

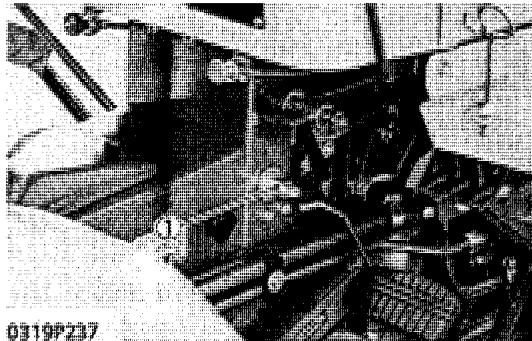

0319P237

Speed Set Lever

1. Measure the force to move the speed set lever (A) forward at its top (grip).
2. If the force is not within the factory specification, turn the nut (1) to adjust.

Force to move the lever	Factory spec.	29.4 to 34.3 N 3.0 to 3.5 kgf 6.6 to 7.7 lbs
-------------------------	---------------	--

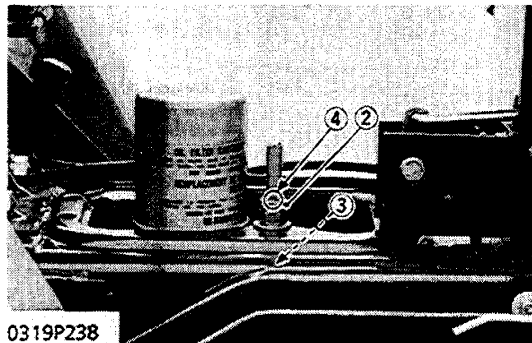

0319P238

(When reassembling)

- After installing the spring (3), align the head of nut (2) with the punched mark (4).

- (1) Nut
- (2) Nut
- (3) Spring
- (4) Punched Mark

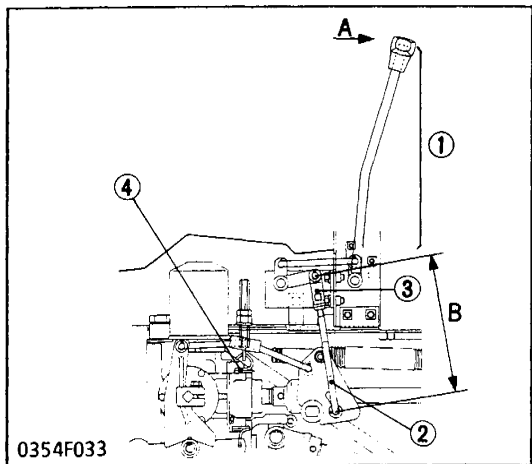

0354F033

Setting Length of Lower Rod

1. Measure the length "B".
2. If the measurement is not within the factory specifications, adjust with the yoke of the lower rod.

Setting length of lower rod	Factory spec.	178 mm 7.01 in.
-----------------------------	---------------	--------------------

- (1) Speed Set Lever
- (2) Lower Rod
- (3) Yoke
- (4) Spring

[2] HYDROSTATIC TRANSMISSION (B1550HST-B1750HST)

NOTE

- The hydrostatic transmission for the tractors from the serial number written right is explained on page BM.3-1 to BM.3-11 and BS.3-1 to BS.3-17.

Models	Serial number
B1550HST (2WD)	above 20001
B1550HST (4WD)	above 60001
B1750HST (2WD)	above 20001
B1750HST (4WD)	above 60001

CHECKING AND ADJUSTING

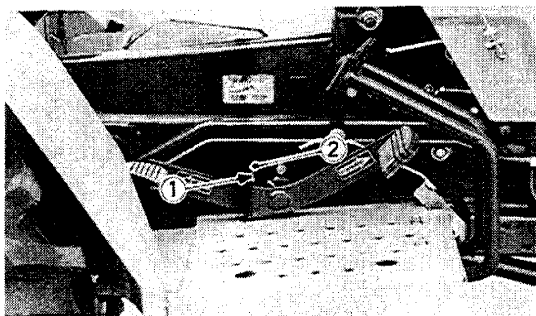

0319P239

Reverse Speed

- Lift the rear of the tractor so that the rear wheels are off the ground.
- Set the engine speed at 2600 rpm and depress the differential lock pedal.
- If the rear wheels do not turn within the factory specifications, loosen the lock nut (1) and adjust the bolt (2).

Rear wheel rpm	Factory spec.	127 to 137 rpm (Engine at 2600 rpm)
----------------	---------------	--

(1) Lock Nut

(1) Lock Nut

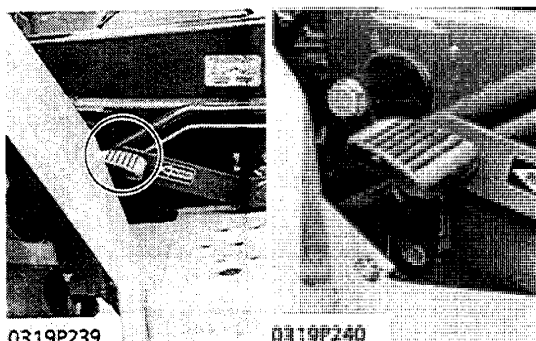

0319P239

0319P240

Neutral

- Lift the rear of the tractor so that the rear wheels are off the ground and run the engine at low idling and drive only rear wheels.
- Depress the one end of speed control pedal and release, and do the same at the other end.
- If the rear wheels do not stop turning, adjust as following procedure.

NOTE

- After taking off the cover, loosen the screw and be sure to place the neutral adjuster with its longer groove upward.

Adjusting Neutral

- Rotate the neutral adjuster counterclockwise so that the rear wheels turn forward.
- Then rotate it clockwise until wheels stop completely.
- Put a mark on the clutch housing aligning the groove on neutral adjuster.
- Rotate the neutral adjuster clockwise so that the rear wheels turn reverse.
- Then rotate it counterclockwise until wheels stop completely.
- Put a mark on the clutch housing aligning the groove on neutral adjuster.
- Hold the neutral adjuster so that its groove is at the middle of the marks and tighten the screw.

NOTE

- When the wheels tend to turn forward, rotate the neutral adjuster clockwise.
- When the wheels tend to turn reverse, rotate the neutral adjuster counterclockwise.

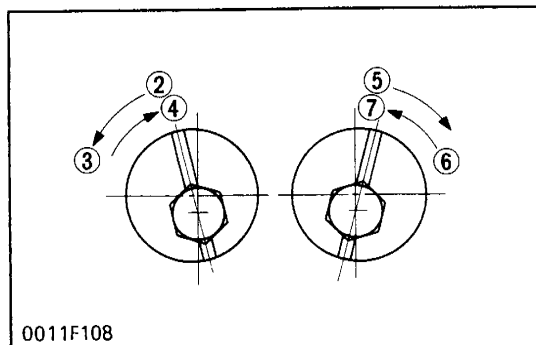

0011F108

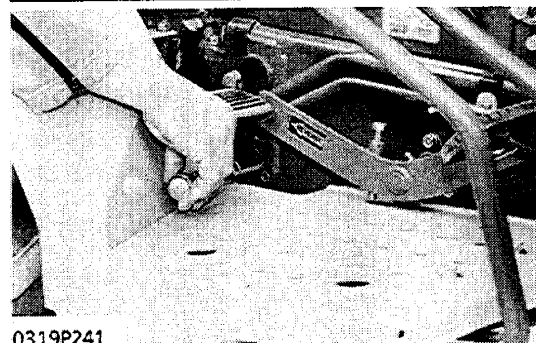

0319P241

Tightening torque	Neutral adjuster to case	19 to 32 N·m 1.9 to 3.3 kgf·m 13 to 24 ft·lbs
-------------------	--------------------------	---

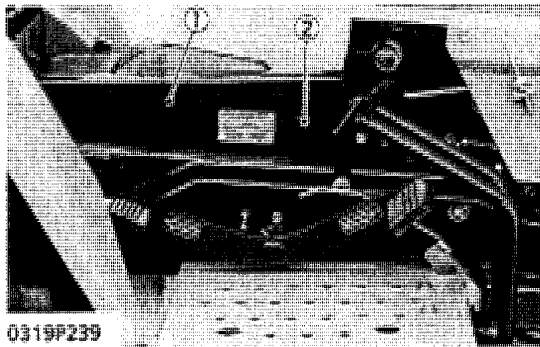

0919P239

Oil Pressure in Hydrostatic Transmission

1. Clean and clear the work area, and fully engage the parking brake.
2. Remove the knob screws (2) and sub cover (1).
3. Measure the following oil pressures using Hydrostatic Transmission Testing Kit (Code No. 07916-52040) as instructed.

(1) Sub Cover

(2) Knob Screw

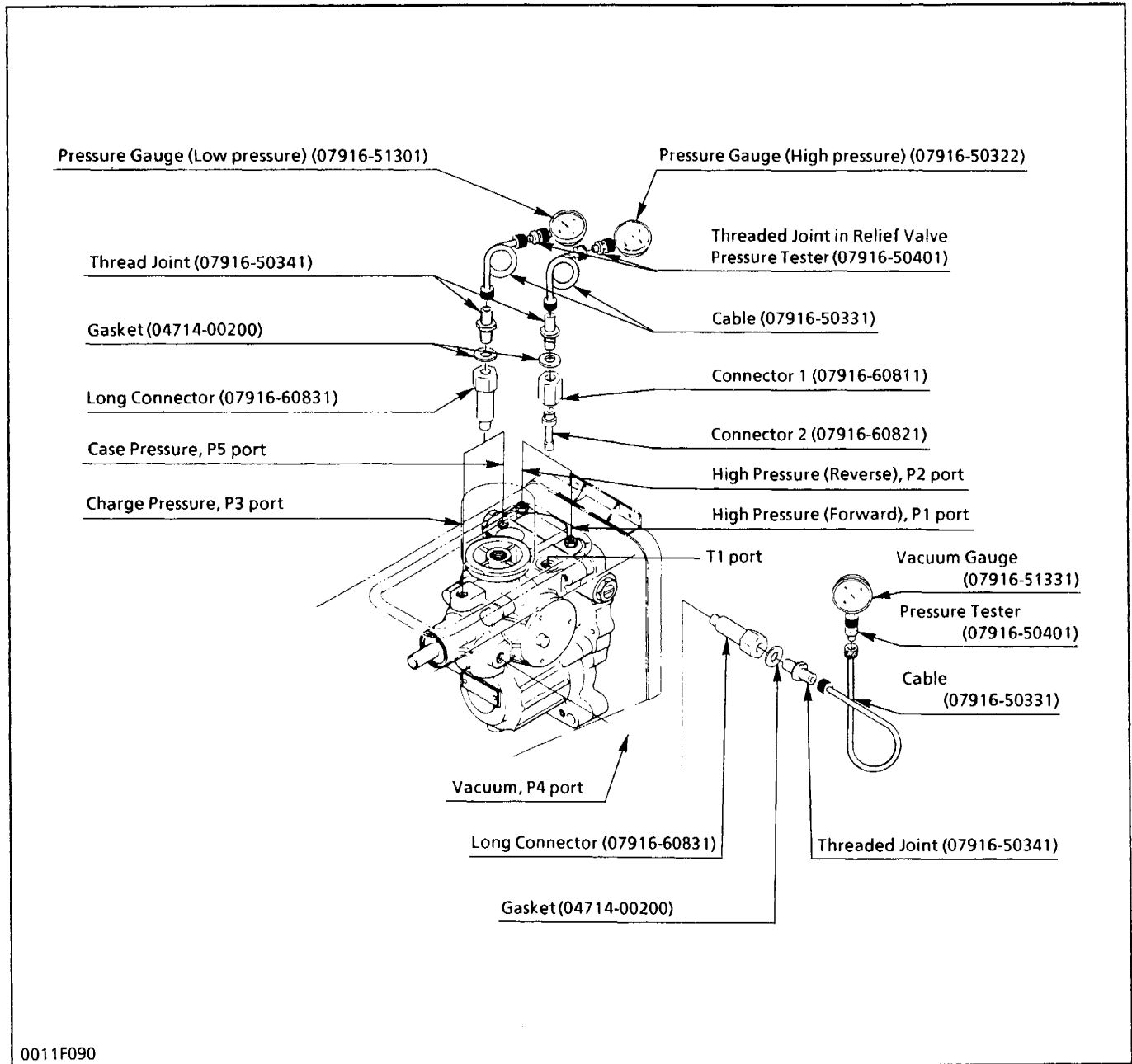

0011F090

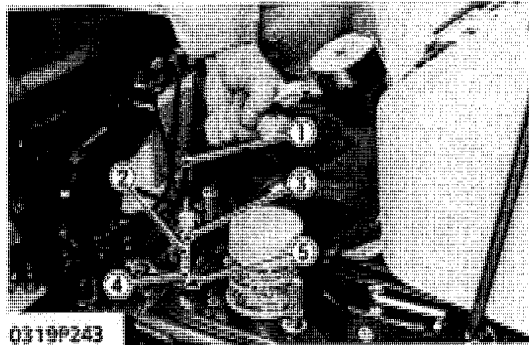
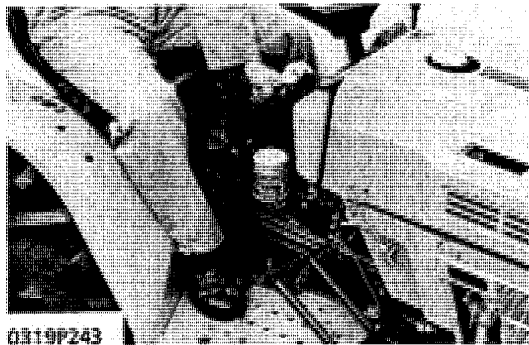
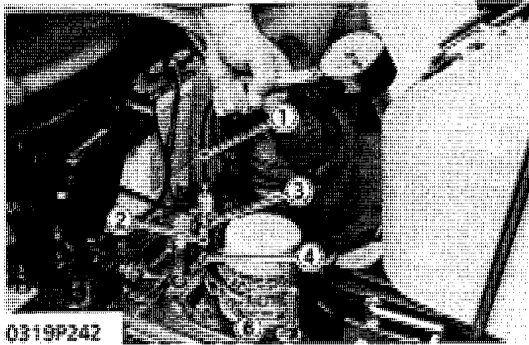
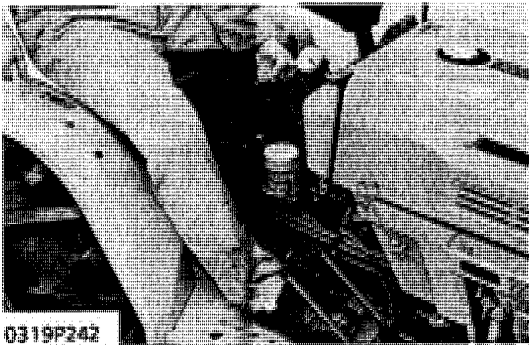

High Relief Pressure

1. Remove the M 10 hex socket head plug from P1 (6) or P2 (5) port (P1 is for forward and P2 is for reverse).
2. Install connector 2 (4) to P1 (forward) or P2 (reverse) port.
3. Assemble connector 1 (2) and threaded joint (3) with the gasket between them.
4. Install the assembled connector 1 (2) and threaded joint (3) to connector 2 (4).
5. Install the cable (1), threaded joint in relief valve set pressure tester and high pressure gauge to threaded joint (3) in order.
6. Run the engine at 2600 rpm.
7. Place the high-low shift lever in high.
8. Depress the speed control pedal approx. 10 mm (0.39 in.) which rotates the trunnion shaft 0.087 rad (5.0°).

High relief pressure (Oil temperature at 25° to 50°C, 77° to 122°F)	Factory spec.	22.6 to 24.5 MPa 230 to 250 kgf/cm ² 3271 to 3555 psi
	Allowable limit	21.6 or 25.5 MPa 220 or 260 kgf/cm ² 3128 or 3697 psi

IMPORTANT

- Measure quickly so that the relief valve may not be in operation more than 10 seconds.

NOTE

- High pressure gauge is 30 MPa (300 kgf/cm², 4260 psi) full scale.

(When reassembling)

- Install the M 10 plug to the port with the gasket laying on its seat.

Tightening torque	Plug (P1, P2 port)	19.6 to 24.5 N·m 2.0 to 2.5 kgf·m 14 to 18 ft-lbs
	Plug seat (P1, P2 port)	54.9 to 58.8 N·m 5.6 to 6.0 kgf·m 41 to 43 ft-lbs

- | | |
|--------------------|-----------------|
| (1) Cable | (4) Connector 2 |
| (2) Connector 1 | (5) P2 Port |
| (3) Threaded Joint | (6) P1 Port |

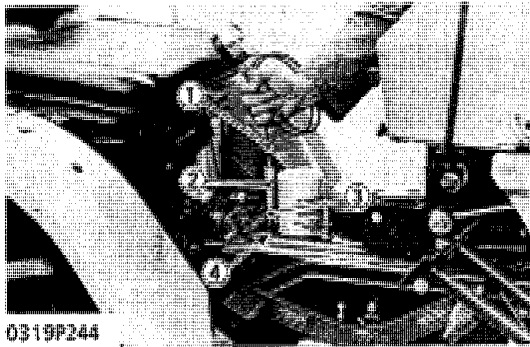

0319P244

- (1) Cable
- (2) Threaded Joint
- (3) Long Connector
- (4) P5 Port

Case and Case Relief Pressure

1. Remove the PT 1/4 plug from P5 port (4), with care not to allow any particle of sealing tape enter into the port.
2. Install the long connector (3) to P5 port with sealing tape on its thread.
3. Install the threaded joint (2) to long connector with the gasket between them.
4. Install the cable (1), threaded joint in relief valve set pressure tester and low pressure gauge to threaded joint in order.
5. Run the engine at 2600 rpm.
6. Place the high-low shift lever in neutral.
7. Release the speed control pedal to set in neutral.
8. After measuring the case pressure, remove the eye joint from T1 port and plug the port with PF 3/8 screw to measure the case relief pressure.

Case relief pressure (Oil temperature at 25° to 50°C, 77° to 122°F)	Factory spec.	167 to 226 kPa 1.7 to 2.3 kgf/cm ² 24.2 to 32.7 psi
	Allowable limit	147 or 245 kPa 1.5 or 2.5 kgf/cm ² 21.3 or 35.6 psi

NOTE

- Low pressure gauge is 2 MPa (20 kgf/cm², 284 psi) full scale.

(When reassembling)

- Install the PT 1/4 plug to the P3 port with the sealing tape on its thread.

Tightening torque	Plug (P5 port)	8.8 to 10.8 N·m 0.9 to 1.1 kgf·m 6.5 to 7.9 ft·lbs
-------------------	----------------	--

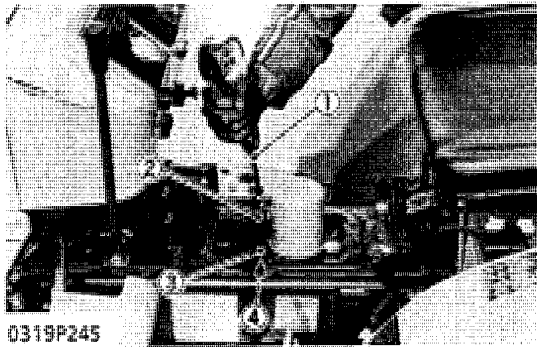

(1) Cable (3) Long Connector
 (2) Threaded Joint (4) P3 Port

Charge Pressure

1. Remove the PT 1/4 plug from P3 port (4), with care not to allow any particle of sealing tape enter into the port.
2. Install the long connector (3) to P3 port with sealing tape on its thread.
3. Install the threaded joint (2) to long connector with the gasket between them.
4. Install the cable (1), and threaded joint in order.
5. Run the engine at 2600 rpm.
6. Place the high-low shift lever in neutral.
7. Release the speed control pedal to set in neutral.

Charge pressure (Oil temperature at 25°C, 77°F)	Factory spec.	441 to 579 kPa 4.5 to 5.9 kgf/cm ² 64.2 to 83.9 psi
	Allowable limit	412 or 608 kPa 4.2 or 6.2 kgf/cm ² 59.7 or 88.2 psi

Charge pressure (Oil temperature at 50°C, 122°F)	Factory spec.	421 to 559 kPa 4.3 to 5.7 kgf/cm ² 61.1 to 81.1 psi
	Allowable limit	392 or 558 kPa 4.0 or 6.0 kgf/cm ² 56.9 or 85.3 psi

■ **NOTE**

- Low pressure gauge is 2 MPa (20 kgf/cm², 284 psi) full scale.

(When reassembling)

- Install the PT 1/4 plug to the P3 port with the sealing tape on its thread.

Tightening torque	Plug (P3 port)	8.8 to 10.8 N·m 0.9 to 1.1 kgf·m 6.5 to 7.9 ft-lbs
-------------------	----------------	--

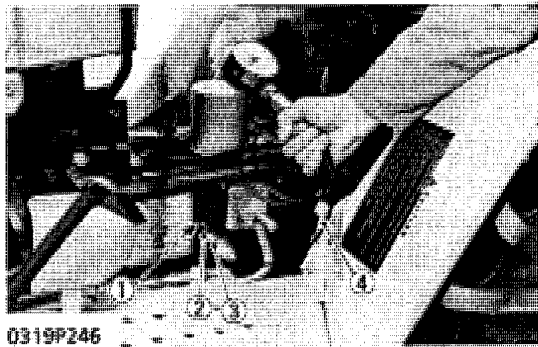

0319P246

- (1) P4 Port
- (2) Long Connector
- (3) Threaded Joint
- (4) Cable

Vacuum

1. Remove the PT 1/4 plug from P4 port (1), with care not to allow any particle of sealing tape enter into the port.
2. Install the long connector (2) to P4 port with sealing tape on its thread.
3. Install the threaded joint (3) to long connector with the gasket between them.
4. Install the cable (4), threaded joint in relief valve set pressure tester and vacuum gauge to threaded joint (3) in order.
5. Run the engine at 2600 rpm.
6. Place the high-low shift lever in neutral.
7. Release the speed control pedal to set in neutral.

Vacuum (Oil temperature)	Factory spec.	120 mm Hg (at 25°C, 77°F) 60 mm Hg (at 50°C, 122°F) 35 mm Hg (at 80°C, 176°F)
	Allowable limit	220 mm Hg (at 80°C, 176°F)

NOTE

- Vacuum gauge is 760 mm Hg (30 in. Hg) full scale.

(When reassembling)

- Install the PT 1/4 plug to the P4 port with the sealing tape on its thread.

Tightening torque	Plug (P3 port)	8.8 to 10.8 N·m 0.9 to 1.1 kgf·m 6.5 to 7.9 ft·lbs
-------------------	----------------	--

DISASSEMBLING AND ASSEMBLING

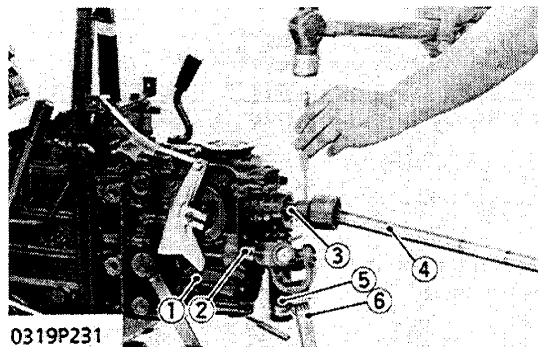

0319P231

- (1) HST
- (2) Front Wheel Drive Shaft
- (3) 1st Shaft
- (4) Propeller Shaft
- (5) Hose
- (6) Drive Shaft

Hydrostatic Transmission

1. Remove the propeller shaft (4) from the 1st shaft (3).
2. Remove the drive shaft (6) from the front wheel drive shaft (2). (4WD type only)
3. Loosen the hole clamp and remove the hose (5).
4. Remove the HST mounting screws, and remove the HST (1).

(When reassembling)

- After inserting the spring pin into the 1st shaft and drive shaft, lock the spring pin with a wire.
- Be sure to replace the gasket with a new one.

Tightening torque	HST mounting screw	48.1 to 55.9 N·m 4.9 to 5.7 kgf·m 35.4 to 41.2 ft·lbs
-------------------	--------------------	---

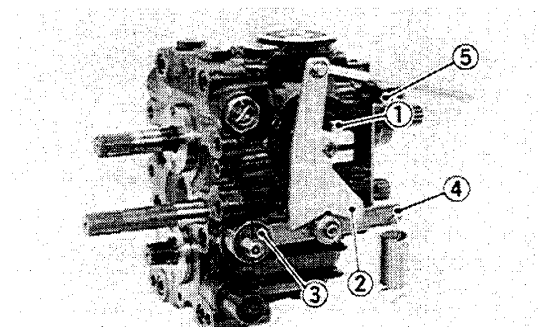

0319P256

- (1) Screw
- (2) Neutral Holder
- (3) Neutral Adjuster
- (4) Neutral Holder Arm
- (5) Spring Holder

Neutral Holder

1. Place parting marks on the neutral adjuster (3) and the neutral holder arm (4).
2. Remove the screws and spring holder (5).
3. Remove the screw and the neutral holder arm (4).
4. Remove the screw (1) and pull out the neutral holder (2).

(When reassembling)

- Aligning the parting marks, install the neutral adjuster and the neutral holder arm.

Tightening torque	Neutral holder arm mounting screw	18.6 to 32.4 N·m 1.9 to 3.3 kgf·m 14 to 24 ft·lbs
-------------------	-----------------------------------	---

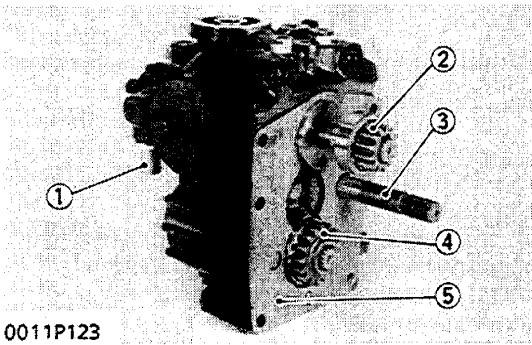

0011P123

- (1) Hose Joint
- (2) 14T Gear
- (3) Front Wheel Drive Shaft 1
- (4) 16T Gear
- (5) Gasket

Front Wheel Drive Shaft 1 and Gears

1. Pull out the front wheel drive shaft 1 (3) forward.
2. Remove the external snap ring and 14T gear (2).
3. Remove the external snap ring and 16T gear (4).
4. Remove the hose joint (1) and gasket (5).

(When reassembling)

- Install the snap ring with its rounded edge facing the gear or bearing so that its sharp edge in the groove keeps itself in place against the force.

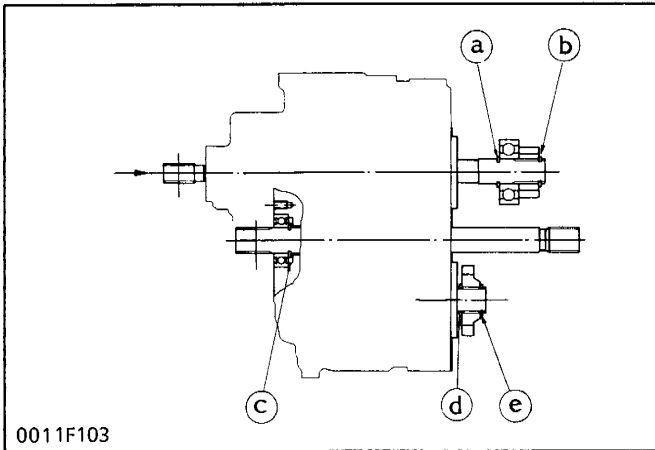

0011F103

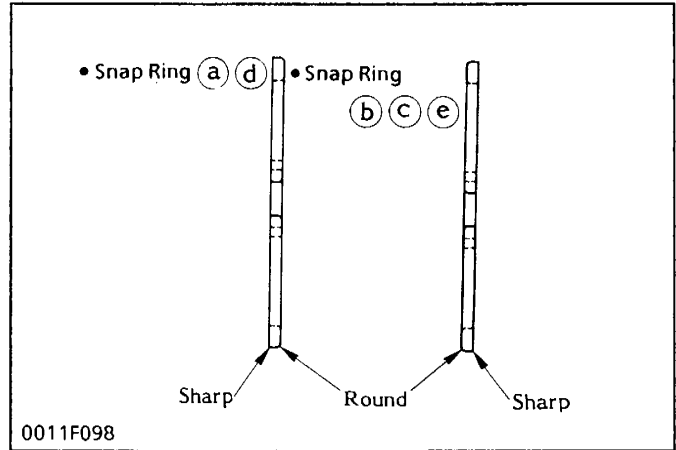

0011F098

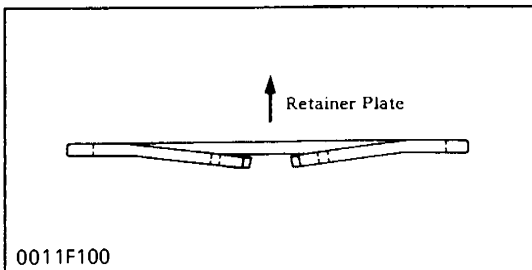

0011F100

Repair-stand for Assembling and Disassembling

1. To facilitate disassembling and assembling, make a repair stand as shown in the figure.

IMPORTANT

- Clean the repair -stand and the outside of the hydrostatic transmission case.
- Hydrostatic transmission is composed of many precision parts and they have highly finished or polished surface.
- Take extreme care to prevent damage or dirt during disassembling and assembling.
- Coat hands with hydrostatic transmission oil before handling the parts to minimize the possibility of rust.
- Clean the parts and coat them with hydrostatic transmission oil before assembling

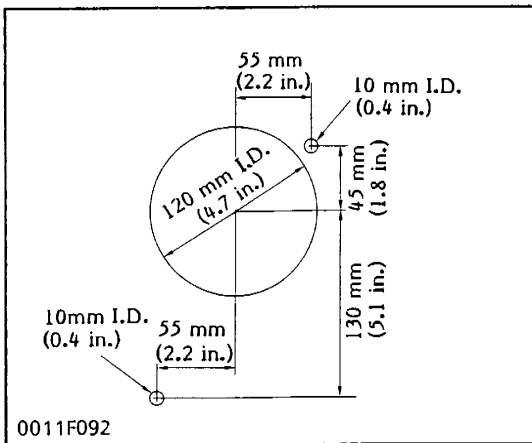

0011F092

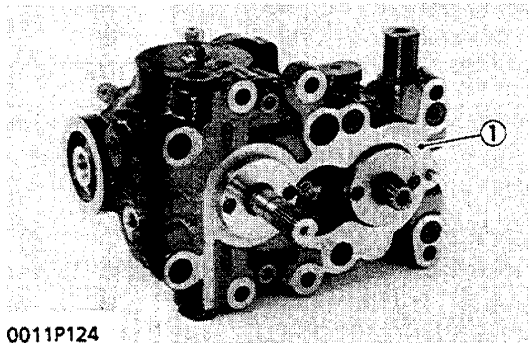

0011P124

Port Block

1. Remove the port block mounting screws, and tap the front of port block (1) flange with a soft hammer to separate.

(When reassembling)

- Cover the splines of each shaft with thin tape to protect the sealing lip.
- Install port block with gasket, O-ring and valve plate in place.

■ IMPORTANT

- Valve plates (2), (3) may stick to the port block, but they are not fixed. Take care not to drop them.
- Valve plates are not interchangeable. Valve plate of the pump has two notches and the valve of the motor has notches.

Tightening torque	Port block to case	22.5 to 27.4 N·m 2.3 to 2.8 kgf·m 17 to 20 ft-lbs
-------------------	--------------------	---

- (1) Port Block
- (2) Pump Valve Plate
- (3) Motor Valve Plate

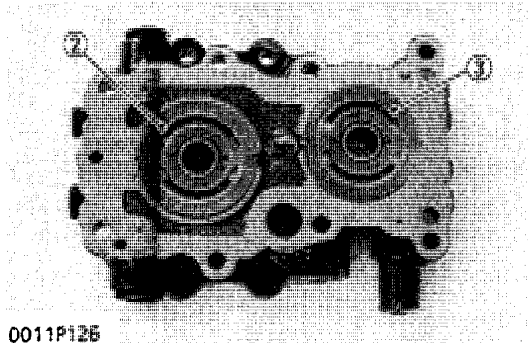

0011P125

Motor Cylinder Block

1. Hold the output shaft (1) and slightly tap the rear of case flange with a soft hammer to separate the motor cylinder block assembly.
2. Slide out the motor cylinder block (2) with pistons (3), retainer plate (4) and retainer holder (5).

(When reassembling)

- Aligning the hole on the swashplate to the dowel pin in the case, and install the output shaft assembly in the case.

- (1) Output Shaft
- (2) Motor Cylinder Block
- (3) Piston
- (4) Retainer Plate
- (5) Retainer Holder

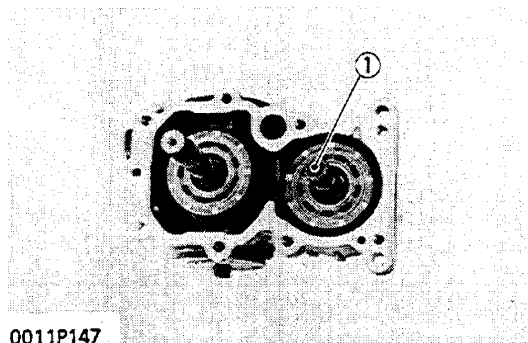

0011P147

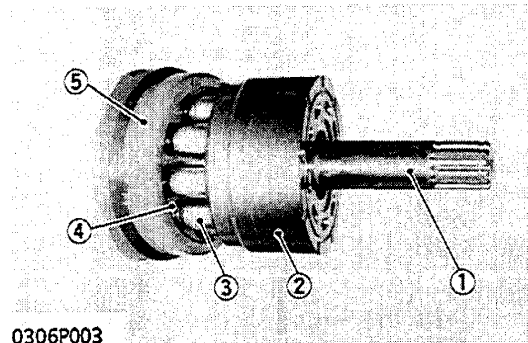

0306P003

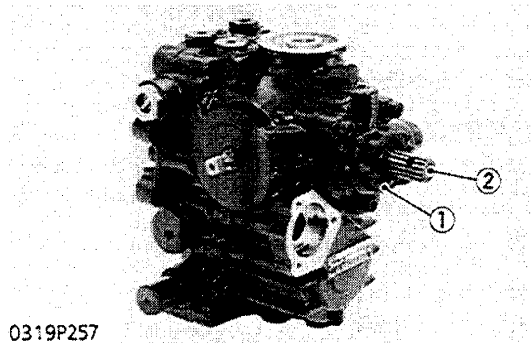
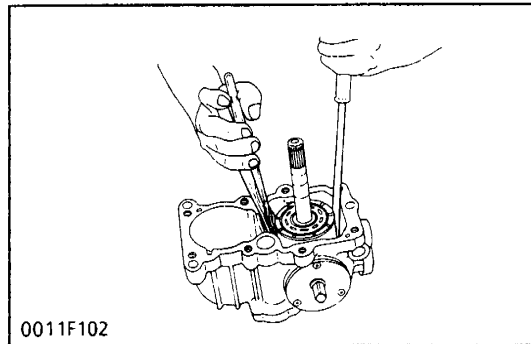
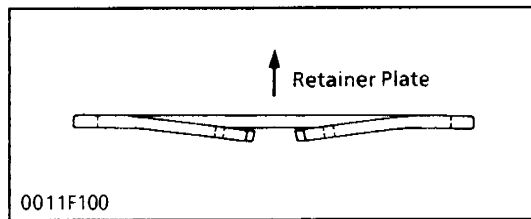
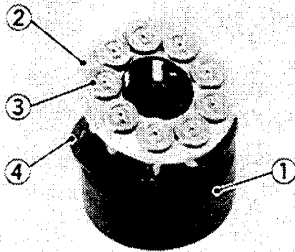
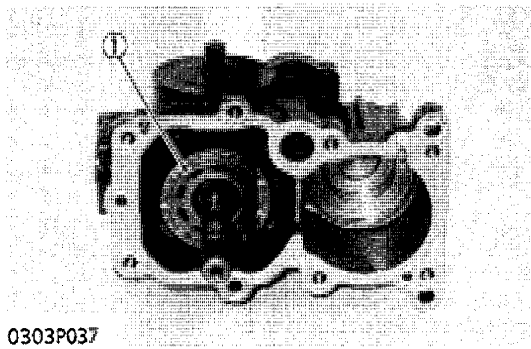

Pump Cylinder Block

1. Remove the internal snap ring retaining the retainer plate of pump.
2. Slide out pump cylinder block (1) with pistons (3) retainer plate (2) and internal snap ring (4).
3. Draw out the thrust plate from the variable swashplate.

(When reassembling)

- Check that internal snap ring (4) faces correct in the direction, and install it to pump swashplate.
- Squeeze the snap ring (4) and slip into the hole its arc first by pushing down with a screwdriver to fit surely.

- | | |
|-------------------------|---------------|
| (1) Pump Cylinder Block | (3) Piston |
| (2) Retainer Plate | (4) Snap Ring |

Charge Pump and Input Shaft

1. Remove the screws retaining the charge pump case (1).
2. Tapping the rear end of the input shaft (2) with a soft hammer, separate the charge pump case (1) with the input shaft (2) from the case.
3. Remove two knock pins.

Tightening torque	Charge pump case to case	10.8 to 13.7 N·m 1.1 to 1.4 kgf·m 8.0 to 10.1 ft·lbs
-------------------	--------------------------	--

- | | |
|----------------------|-----------------|
| (1) Charge Pump Case | (2) Input Shaft |
|----------------------|-----------------|

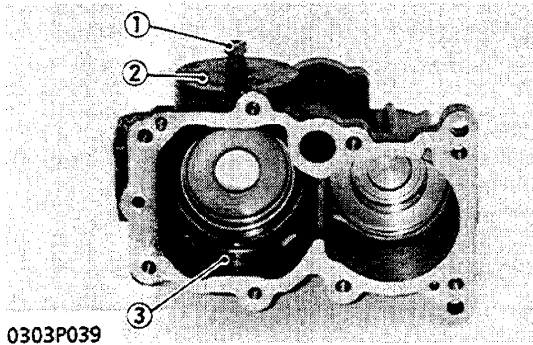

Pump Swashplate

1. Remove the screws retaining trunnion shaft cover.
2. Tap the end of trunnion shaft (1) with a soft hammer to separate the trunnion shaft cover 2 (3).
3. Tap the end of shaft with a soft hammer to separate the trunnion shaft cover 1 (2).

(When reassembling)

- Install the trunnion shaft covers (2), (3) with the seam of bearing (4), (5) facing forward (machined surface side of case).

Tightening torque	Cover mounting screw	2.0 to 2.5 N·m 0.20 to 0.26 kgf·m 1.4 to 1.9 ft·lbs
-------------------	----------------------	---

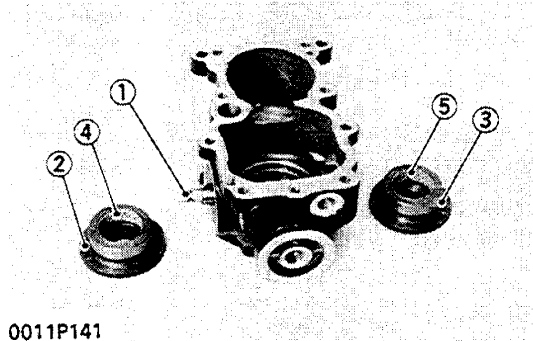

- (1) Trunnion Shaft
- (2) Trunnion Shaft Cover 1
- (3) Trunnion Shaft Cover 2
- (4) Seam of Bearing
- (5) Seam of Bearing

SERVICING

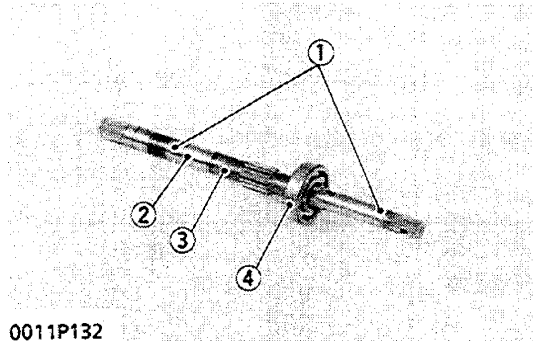

Input Shaft

1. Pull out input shaft (3) with the bearing on it from the charge pump case.
2. Check the seal surface (1), the bearing surface (2) and the bearing (4).
3. If the shaft is rough or grooved, replace.
4. If the bearing is worn, replace.

- (1) Seal Surface
- (2) Bearing Surface
- (3) Input Shaft
- (4) Bearing

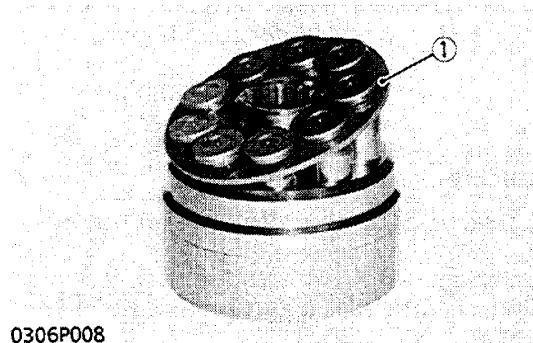

Cylinder Block Bore and Pistons

1. Lift all the pistons gently with the retainer plate (1).
2. Check the pistons for their free movement in the cylinder block bores.
3. If the piston or the cylinder block bore is scored, replace the cylinder block assembly.

Clearance between piston and bore	Factory spec.	0.02 mm 0.0008 in.
-----------------------------------	---------------	-----------------------

- (1) Retainer Plate

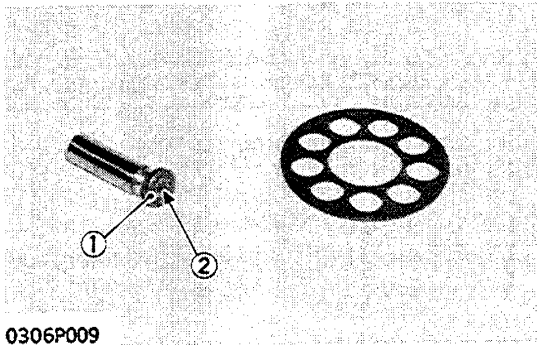

Piston Slipper and Retainer Plate

1. Check the slipper (1) for flatness.
2. If rounded, replace.
3. Measure the thickness of piston slipper.
4. If the measurement is less than the allowable limit, replace.
5. Check the lubricant hole (2) for clogging.
6. If clogged, open hole with compressed air.

Thickness of slipper	Factory spec.	3.00 mm 0.118 in.
	Allowable limit	2.90 mm 0.114 in.

(1) Piston Slipper (2) Lubricant Hole

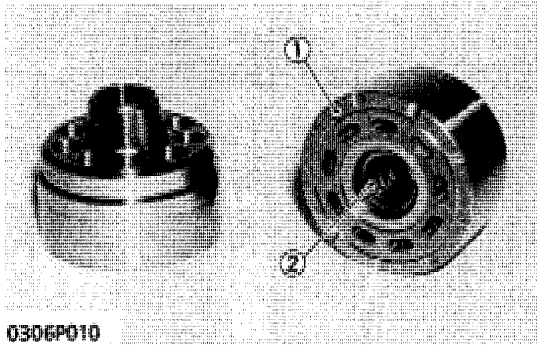

Cylinder Block Face

1. Check the polished face (1) of cylinder block for scoring.
2. If scored, replace the cylinder block assembly.
3. Check the spring (2) for breakage.
4. If broken, replace the cylinder block assembly.

(1) Polished Face (2) Spring

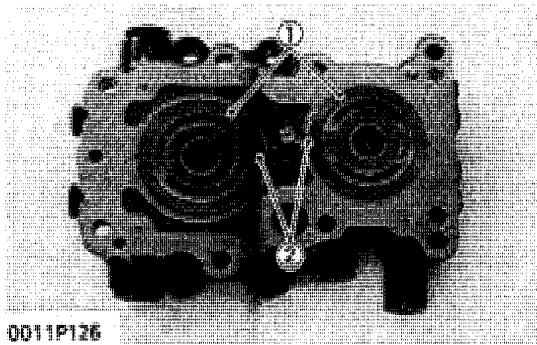

Valve Plate

1. Check the engagement of the valve plate (1) and the anchor pin (2).
2. Pushing the valve plate against the anchor pin, lift it to remove.
3. Check the valve place for foreign particles.
4. Clean the valve plate and dry with compressed air.
5. Check the valve plate for scratches, wear and erosion.
6. If worn or scored, replace.

NOTE

- Run a fingernail across the valve plate surface. If worn, it will be felt. After checking, coat them with hydrostatic transmission oil.

(1) Valve Plate (2) Anchor Pin

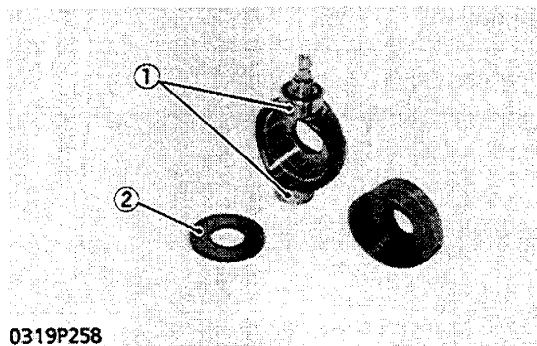

Swashplate and Thrust Plate

1. Check the bearing surface of trunnion shaft (1) for scratches and excessive wear.
2. If worn or scored, replace.
3. Check the thrust plate (2) for scratches and excessive wear.
4. If worn or scored, replace.

(1) Bearing Surface (2) Thrust Plate

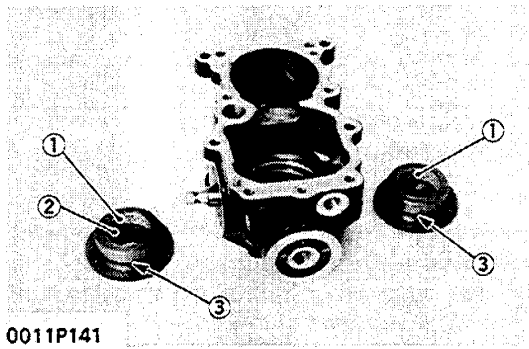

0011P141

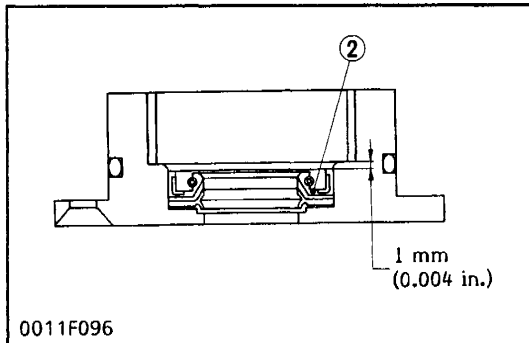

0011F096

Trunnion Shaft Cover

1. Check the bearings (1) for scratches and excessive wear.
2. If worn or scored, replace.
3. Check the oil seal (2) and the O-ring (3) for damage.

■ NOTE

- After checking, coat the bearing with hydrostatic transmission oil, and the oil seal lip and the O-ring with grease.
- When replace the oil seal (2), press it in the trunnion shaft cover until it is 1 mm (0.039 in.) below the shoulder and obtain the clearance under it.

- (1) Bearing
(2) Oil Seal

- (3) O-ring

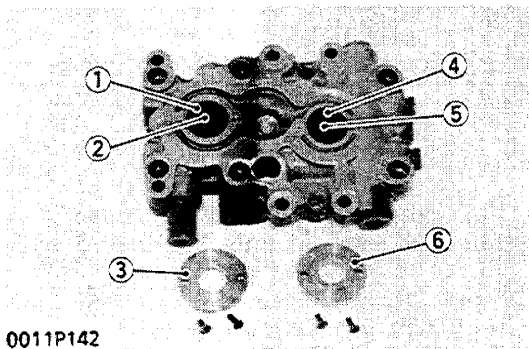

0011P142

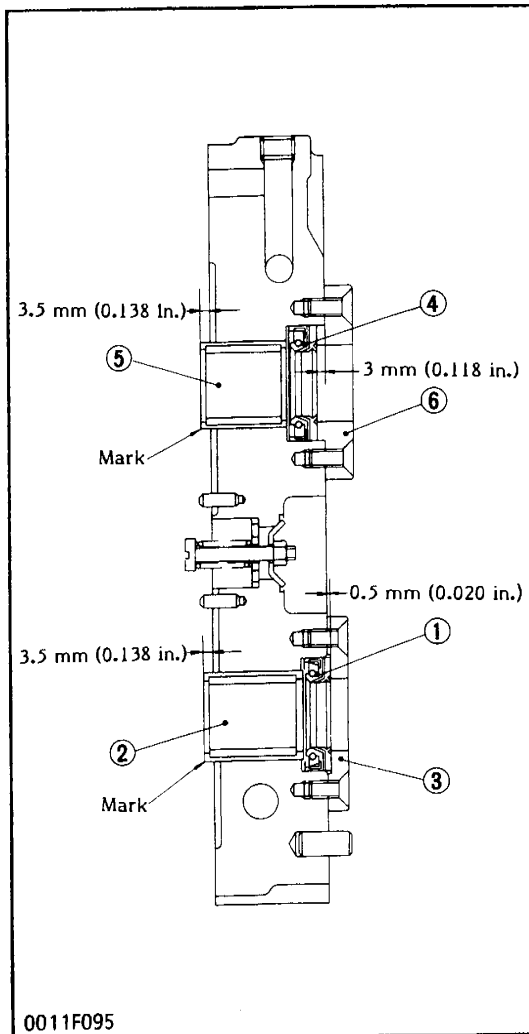

0011F095

Oil Seal and Bearing

1. Remove the flanges (3), (6) and check the oil seals (1), (4) for damage.
2. Check the bearings (2), (5) for wear.
3. If the bearings are worn, replace.

NOTE

- After checking, coat the bearing with hydrostatic transmission oil and the oil seal lip with grease.
- When replacing the bearing, press it in the port block so that its mark faces outside and 3.5 mm (0.318 in.) of it remains above the machined surface.
- When reassembling, always replace the oil seal as follows.
- Press the oil seal (4) in the port block until it is 3 mm (0.118 in.) below the machined surface using the flange 1 (6).
- Press the oil seal (1) in the port block until so that 0.5 mm (0.020 in.) of it remains above the machined surface using the flange 2 (3).

- (1) Oil Seal
(2) Bearing
(3) Flange 2

- (4) Oil seal
(5) Bearing
(6) Flange 1

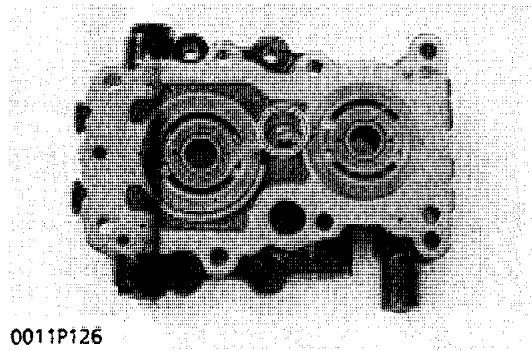

0011P126

Case Relief Valve

1. Check the valve and the spring for excessive wear and breakage.
2. If worn or broken, replace.

Length of valve spring	Factory spec.	25.95 mm, 1.022 in. (free)
		20.0 mm, 0.787 in. (load 29.4 N, 3.00 kgf, 6.62 lbs)
		17.5 mm, 0.089 in. (load 41.8 N, 4.26 kgf, 9.39 lbs)

NOTE

- The screw and the nut should be tightened fully, and then 3 to 3.5 mm (0.118 to 0.138 in.) of the thread on the screw will extend from the nut.

Tightening torque	Screw and nut	1.7 to 2.3 N·m 0.17 to 0.23 kgf·m 1.2 to 1.7 ft·lbs
-------------------	---------------	---

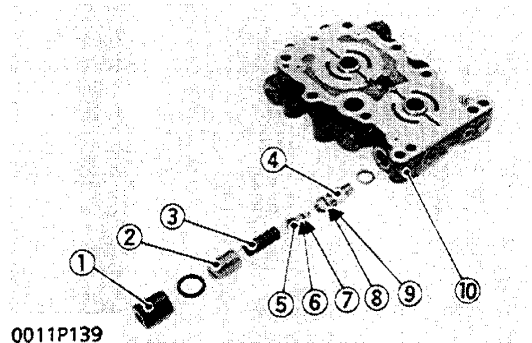

0011P139

- | | |
|------------------|-----------------|
| (1) Cap Nut | (6) Backup Ring |
| (2) Set Screw | (7) O-ring |
| (3) Spring | (8) Backup Ring |
| (4) Valve Seat | (9) O-ring |
| (5) Poppet Valve | (10) Port Block |

High Pressure Relief Valve

1. Remove the cap nut (1).
2. Put an alignment mark across the seat screw (2) and the port block (10) and measure its height from the port block to get the same setting pressure when reassembling.
3. Remove the valve seat (4) using the valve seat driver, which is shown in figure.
4. Check the poppet valve (5) for scratches and damage.
5. Check the O-ring (7), (9) and the backup rings (6), (8) for damage.
7. Check the spring (3) for breakage and wear.
8. If anything unusual, replace the high pressure relief valve complete assembly.

Length of valve spring	Factory spec.	40.00 mm, 1.575 in. (free)
		34.0 mm, 1.339 in. (load 612 N, 62.4 kgf, 6.138 lbs)
		32.5 mm, 1.280 in. (load 765 N, 78.0 kgf, 172 lbs)

NOTE

- When reassembling, replace the O-ring and bonded seal.
- When the setting height of the seat screw (2) is not known, tighten it temporarily and adjust after reassembling the tractor.
- After reassembling the tractor, check the setting pressure and adjust by turning the set screw (2).

Tightening torque	Cap nut	58.8 to 68.6 N·m 6.0 to 7.0 kgf·m 43 to 51 ft·lbs
	Valve seat set screw	23.5 to 29.4 N·m 2.4 to 3.0 kgf·m 17 to 22 ft·lbs

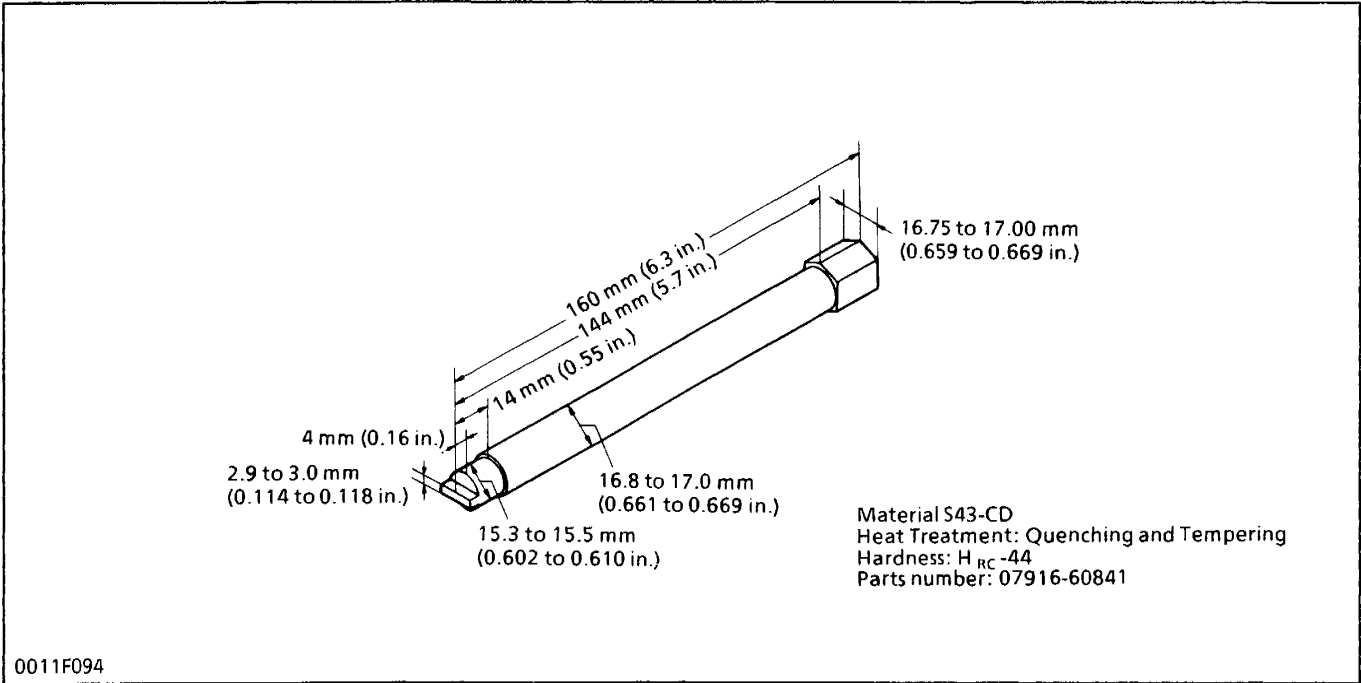

0011F094

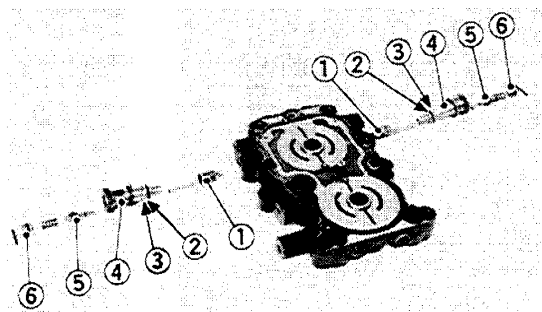

0011P138

- (1) Check Valve
- (2) O-ring
- (3) Backup Ring
- (4) Valve Body
- (5) Neutral Valve
- (6) O-ring

Neutral and Check Valves

1. Remove the valve assembly and disassemble it.
2. Check the check valve (1) and the neutral valve (5) for their free movement on or in the valve body (4).
3. If the valve surface is scored, replace.
4. Check the holes of the valve body (4) and the neutral valve (5) for clogging.
5. If clogged, open hole with compressed air.
6. Check the O-rings (2), (6) and the backup ring (3) for scratches and damage.
7. Check the springs for breakage and wear.
8. If anything unusual, replace.

Length of valve spring (short) (neutral valve)	Factory spec.	19.71 mm, 0.7760 in. (free)
		15.00 mm, 0.591 in. (load 27 N, 2.7 kgf, 6.0 lbs)
		11.00 mm, 0.43 in. (load 49.0 N, 5.0 kgf, 11.0 lbs)
Length of valve spring (long) (neutral valve)	Factory spec.	29.7 mm, 1.1691 in. (free)
		15.0 mm, 0.591 in. (load 17.0 N, 1.7 kgf, 3.7 lbs)
		11.0 mm, 0.43 in. (load 21.18 N, 2.16 kgf, 4.76 lbs)
Length of valve spring (check valve)	Factory spec.	26.91 mm, 1.0594 in. (free)
		19.5 mm, 0.768 in. (load 3.128 N, 0.319 kgf, 0.703 lbs)
		16.2 mm, 0.638 in. (load 4.511 N, 0.460 kgf, 1.014 lbs)

NOTE

- When reassembling, replace the O-ring and the backup rings.

Tightening torque	Valve body to case	34.3 to 39.2 N·m 3.5 to 4.0 kgf·m 25 to 29 ft-lbs
-------------------	--------------------	---

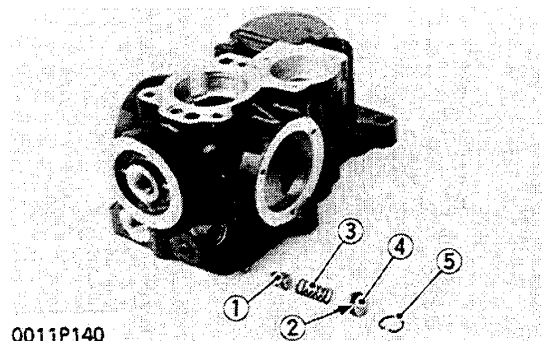

0011P140

- (1) O-ring
- (2) O-ring
- (3) Spring
- (4) Spring Holder
- (5) Snap Ring

Charge Relief Valve

1. Remove the internal snap ring (5) and draw out the spring holder (4).
2. Check the spring (3) for breakage and wear.
3. Check the O-ring (1), (2) for damage.
4. If anything unusual, replace.

NOTE

- Install the internal circlip with its sharp edge facing outside.

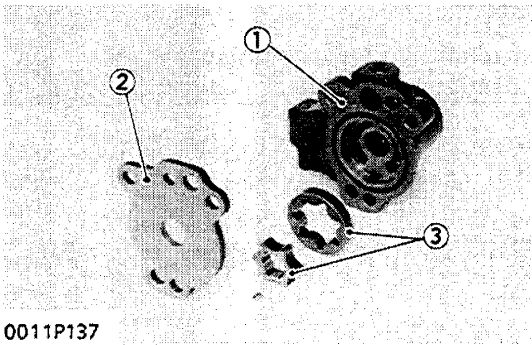

Charge Pump

1. Check the charge pump case (1), the plate (2) and the gerotor set (3) for scratches and wear.
2. If scratched or worn, replace the charge pump complete assembly.
3. Measure the side clearance referring to the figure.
4. If the clearance exceeds the factory specification, replace the charge pump complete assembly.

Side clearance	Factory spec.	0.030 to 0.060 mm 0.0018 to 0.0236 in.
----------------	---------------	---

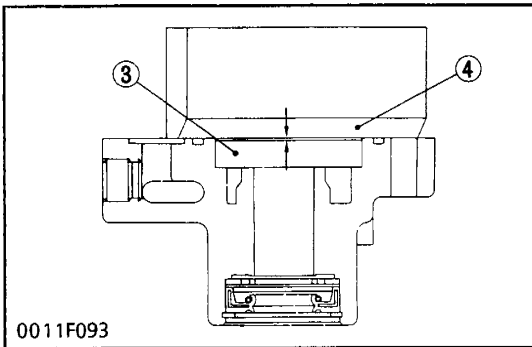

NOTE

- When reassembling, replace the O-rings and the oil seals, and grind the surface of the plate (2) and the charge pump case (1) with finest oil stone.

- | | |
|----------------------|-------------------|
| (1) Charge Pump Case | (3) Gerotor Set |
| (2) Plate | (4) Straight Edge |

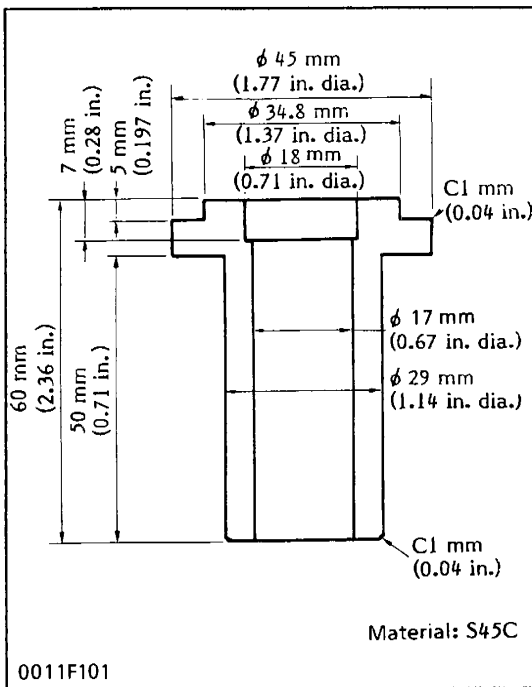

Special Tool A for Pressing Oil Seal

1. Make the special tools shown in figure and reassemble the charge pump according to following directions.

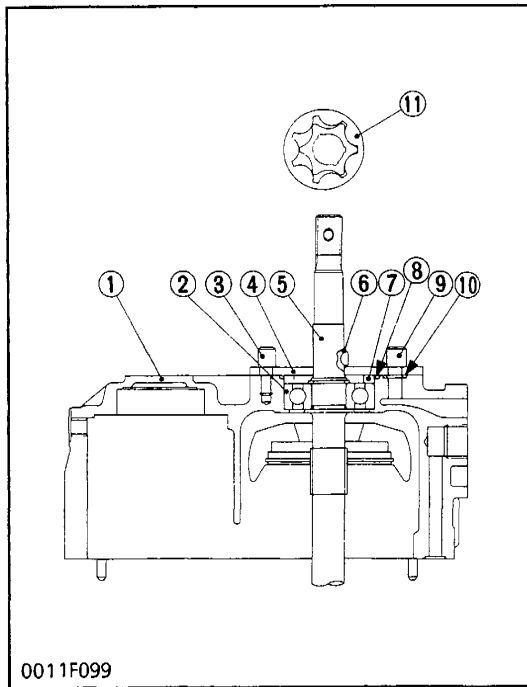

Reassembling (1)

1. Place the swashplate in neutral and install the input shaft (5) to the case (1) with the bearing (2) on it.
2. Install the collar (7) on the bearing (2).
3. Coat the O-rings (8), (10) with hydrostatic transmission oil and install them on the case (1).
4. Install the dowel pins (3), (9) and the plate (4).
5. Grind the key (6) with fine oil stone and install in it the groove of the input shaft (5).
6. Install the gerotor set (11), noting the location of groove for the key.

- | | |
|-----------------|------------------|
| (1) Case | (7) Collar |
| (2) Bearing | (8) O-ring |
| (3) Dowel Pin | (9) Dowel Pin |
| (4) Plate | (10) O-ring |
| (5) Input Shaft | (11) Gerotor Set |
| (6) Key | |

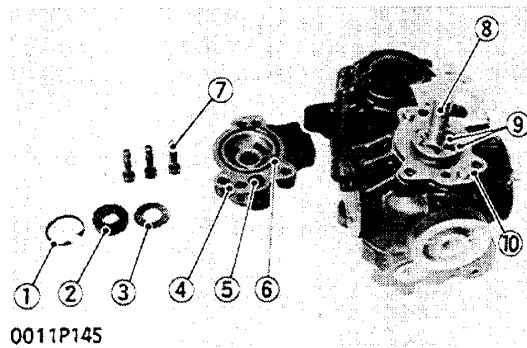

Reassembling (2)

1. Coat the O-rings (5), (6) with hydrostatic transmission oil and install them on the charge pump case (4).
2. Install the charge pump case (4) on the plate (10) and the gerotor set (9), and screw the screws (7) lightly.
3. Press the plate (3) in the charge pump case (4).
4. Cover the splines and the shoulder of the input shaft (8) with thin tape.
5. Press the oil seal (2) in the charge pump case using the special tool (A), until it is 4 mm (0.157 in.) below the machined surface.
6. Install the internal snap ring (1) with its sharp edge facing outside.
7. Tighten the screws (7).

Tightening torque	Charge pump case to case	10.8 to 13.7 N·m 1.1 to 1.4 kgf·m 8.0 to 10.1 ft-lbs
-------------------	--------------------------	--

- | | |
|----------------------|-----------------|
| (1) Snap Ring | (6) O-ring |
| (2) Oil Seal | (7) Screw |
| (3) Plate | (8) Input Shaft |
| (4) Charge Pump Case | (9) Gerotor Set |
| (5) O-ring | (10) Plate |

[3] TRANSMISSION CASE (B1550HST-B1750HST)

DISASSEMBLING AND ASSEMBLING

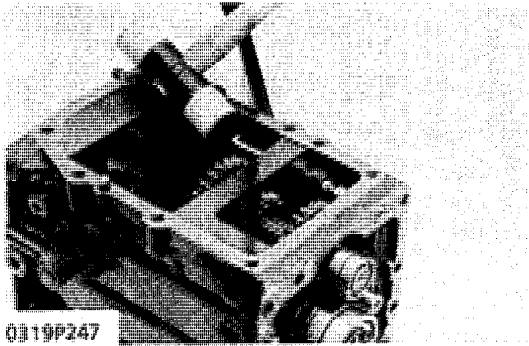

Fork Shaft and Shift Fork

1. Remove the fork shaft lock screw (1).
2. Screw M8 screw (pitch 1.25 x 70 mm long, pitch 1.25 x 2.76 in. long) into the fork shaft (3), and tap out it to the rear.
3. Remove the shift fork (2).

(When reassembling)

- Install the fork shaft with the groove (4) facing the differential gear case (5).

- | | |
|---------------------------|----------------------------|
| (1) Fork Shaft Lock Screw | (4) Groove |
| (2) Shift Fork | (5) Differential Gear Case |
| (3) Fork Shaft | |

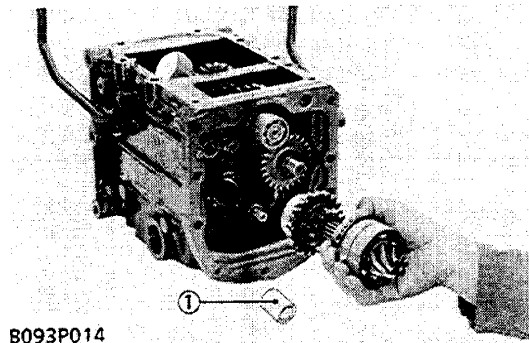
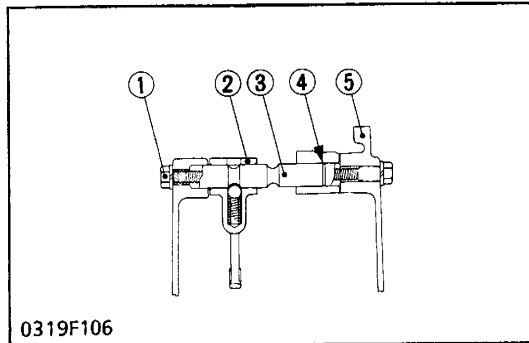

Spiral Bevel Pinion Shaft

1. Remove the coupling (1).
2. Remove the spiral bevel pinion with gears and bearings on it.

- | |
|--------------|
| (1) Coupling |
|--------------|

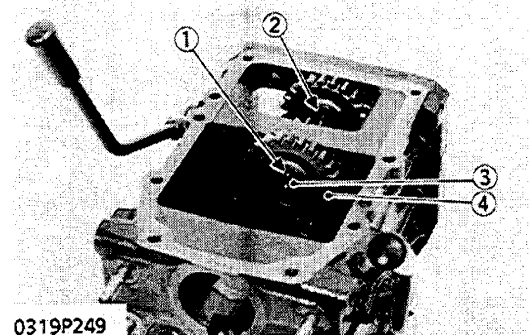

4th Shaft

1. Remove the external snap ring (1) and shift the external snap ring (2) forward.
2. Tapping out the 4th shaft (3) rearward, remove the 24T gear (4).
3. Take out the 4th shaft with the gears and the bearing on it.

- | | |
|---------------|---------------|
| (1) Snap Ring | (3) 4th Shaft |
| (2) Snap Ring | (4) 24T Gear |

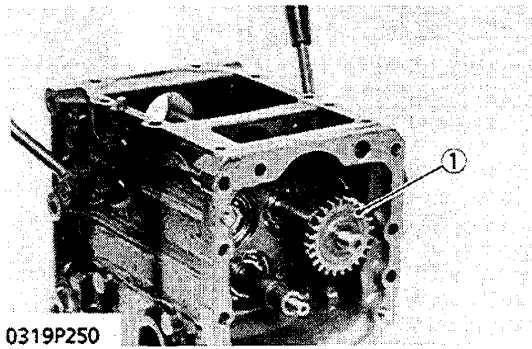

0319P250

Front Wheel Drive Shaft

1. Remove the 23T gear (1).
2. Remove the internal snap ring (2).
3. Draw out the front wheel drive shaft (3).

(1) 23T Gear
(2) Snap Ring

(3) Front Wheel Drive Shaft

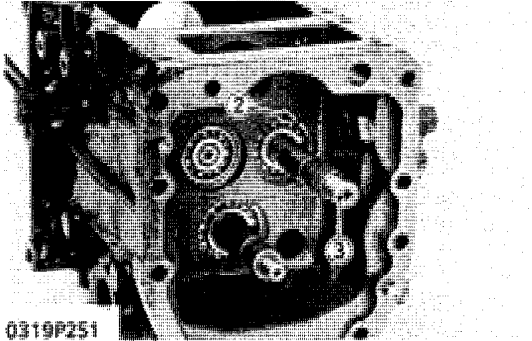

0319P251

2nd Shaft and 29T-14T-18T Gear

1. Remove the external snap ring (1).
2. Remove 14T gear (2).
3. Tap out the 2nd shaft (3) rearward.
4. Take out the 29T-14T-18T gear.

(1) Snap Ring
(2) 14T Gear

(3) 2nd Shaft

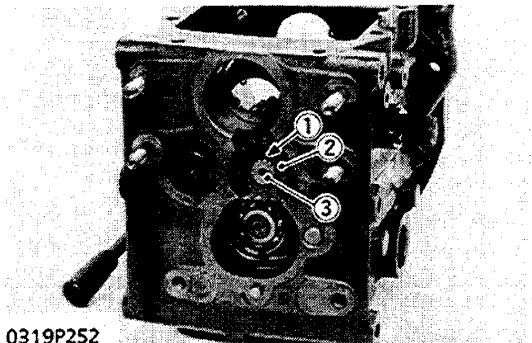

0319P252

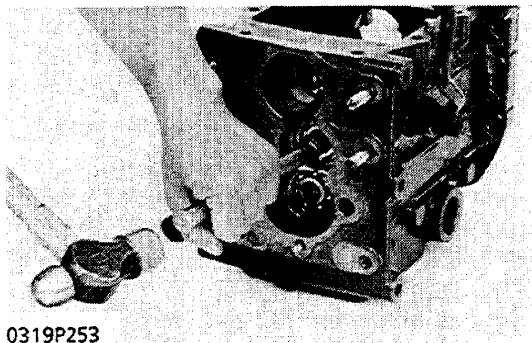

0319P253

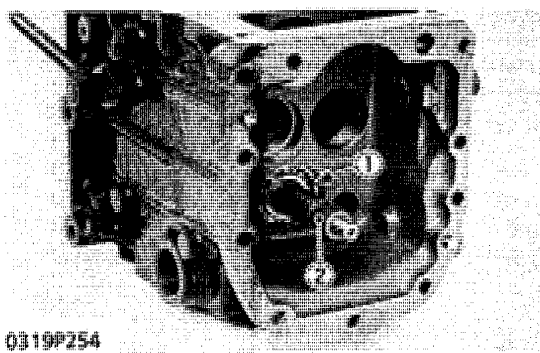

3rd shaft and 21T, 21T and 17T Gear

1. Remove the internal snap ring (1).
2. Tap out the 3rd shaft (2) rearward.
3. Take out the 21T, 21T and 17T gear.

(1) Snap Ring

(2) 3rd Shaft

0319P254

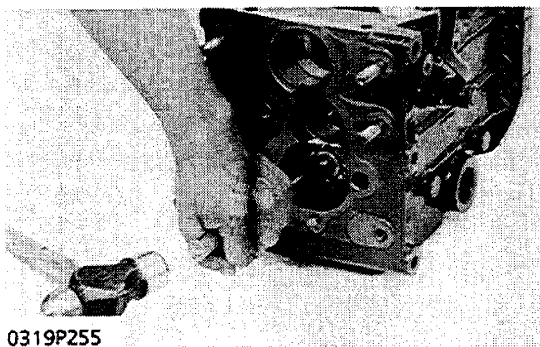

0319P255

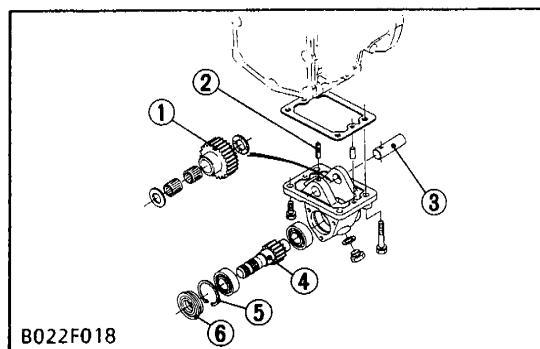

Mid-PTO

1. Separate the mid-PTO case from the transmission case.
2. After tapping the spring pin (2) into the shaft (3), remove the shaft (3) and the 24T gear (1).
3. Remove the oil seal (6) and the external snap ring (5).
4. Draw out the 11T gear shaft (4) with the bearing on it.

Tightening torque	Plug	32.5 to 36.2 N·m 4.5 to 5.0 kgf·m 44 to 49 ft-lbs
	Mid-PTO case to transmission case	48.0 to 55.9 N·m 4.9 to 5.7 kgf·m 35 to 41 ft-lbs

B022F018

- | | |
|----------------|--------------------|
| (1) 24T Gear | (4) 11T Gear Shaft |
| (2) Spring Pin | (5) Snap Ring |
| (3) Shaft | (6) Oil Seal |

SERVICING

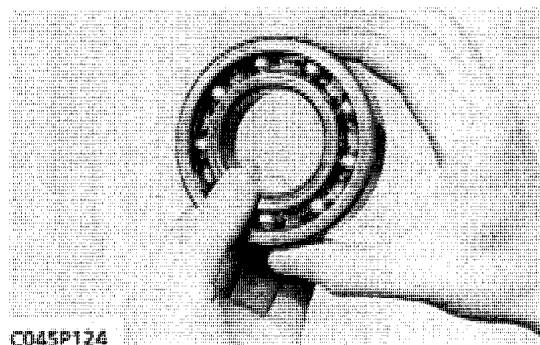

Checking Bearing

1. Hold the inner race, and push and pull the outer race in all directions to check for wear and roughness.
2. Apply transmission oil to the bearing, and hold the inner race. Then, turn the outer race to check rotation.
3. If there is any defect, replace.

C045P124

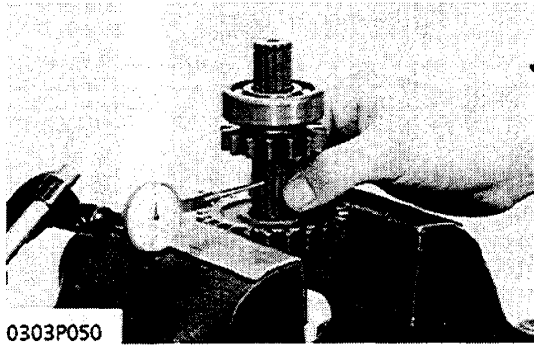

0303P050

Backlash between Gear and Spline

1. Secure the shaft in a vise.
2. Set a dial indicator (lever type).
3. Move the gear by hand for measurement.
4. If the measurement exceeds the allowable limit, replace it.

Backlash between gear and spline	Factory spec.	0.03 to 0.08 mm 0.0012 to 0.003 in.
	Allowable limit	0.20 mm 0.008 in.

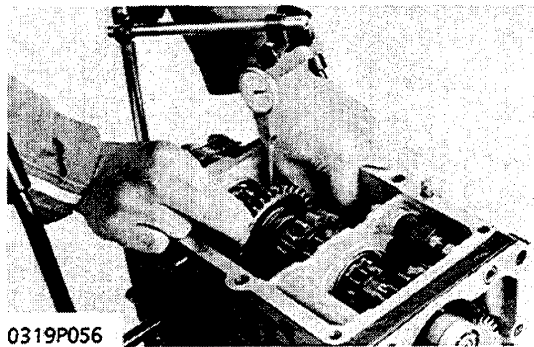

0319P056

Gear Backlash

1. Set a dial indicator (lever type) with its finger on the tooth surface.
2. Move the gear to measure the backlash, while holding the mating gear.
3. If the measurement exceeds the allowable limit, replace.

Gear backlash	Factory spec.	0.10 to 0.20 mm 0.004 to 0.008 in.
	Allowable limit	0.4 mm 0.016 in.

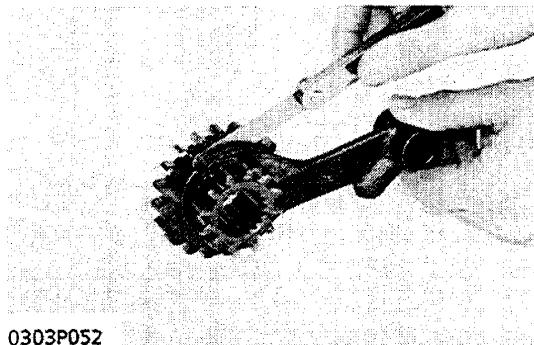

0303P052

Clearance between Shift Fork and Shift Gear Groove

1. Place the shift fork in the shift gear groove and measure the clearance with a feeler gauge.
2. If the clearance exceeds the allowable limit, replace.

Clearance between shift fork and gear groove	Factory spec.	0.10 to 0.30 mm 0.004 to 0.012 in.
	Allowable limit	0.5 mm 0.020 in.

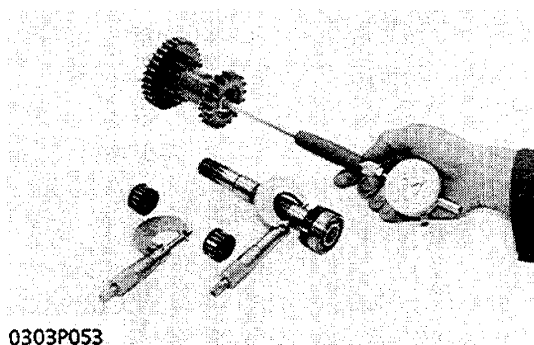

0303P053

Clearance between 29T-14T-18T Gear and 2nd Shaft

1. Measure the 29T-14T-18T gear I.D. with an inside micrometer, and then 2nd shaft O.D. with an outside micrometer.
2. Measure the O.D. of two needles in the needle bearing with an outside micrometer.
3. Clearance is the difference between the gear I.D. and the sum of shaft O.D. and two needles O.D.
4. If the clearance exceeds the allowable limit, replace.

Clearance between 29T-14T-18T gear and 2nd shaft	Factory spec.	0.007 to 0.053 mm 0.0003 to 0.0021 in.
	Allowable limit	0.1 mm 0.039 in.

2nd shaft O.D.	Factory spec.	21.987 to 22.000 mm 0.8656 to 0.8661 in.
----------------	---------------	---

19T-14T-18T gear I.D.	Factory spec.	28.007 to 28.028 mm 1.1026 to 1.1035 in.
-----------------------	---------------	---

Needle O.D.	Factory spec.	29.94 to 30.00 mm 0.1179 to 0.1181 in.
-------------	---------------	---

Clearance between 21T, 17T Gear and 3rd Shaft

1. Measure the 21T, 17T gear I.D. with an inside micrometer, and then 3rd shaft O.D. with an outside micrometer.
2. Measure the O.D. of two needles on the needle bearing with an outside micrometer.
3. Clearance is the difference between the gear I.D. and the sum of shaft O.D. and two needles O.D.
4. If the clearance exceeds the allowable limit, replace.

Clearance between 21T, 17T gear and 3rd shaft	Factory spec.	0.007 to 0.053 mm 0.0003 to 0.0021 in.
	Allowable limit	0.1 mm 0.039 in.
3rd shaft O.D.	Factory spec.	24.987 to 25.000 mm 0.9837 to 0.9843 in.
21T, 17T gear I.D.	Factory spec.	29.007 to 29.028 mm 1.1420 to 1.1428 in.
Needle O.D.	Factory spec.	1.997 to 2.000 mm 0.0786 to 0.0787 in.

[4] TRANSMISSION CASE (B1550-B1750)

DISASSEMBLING AND ASSEMBLING

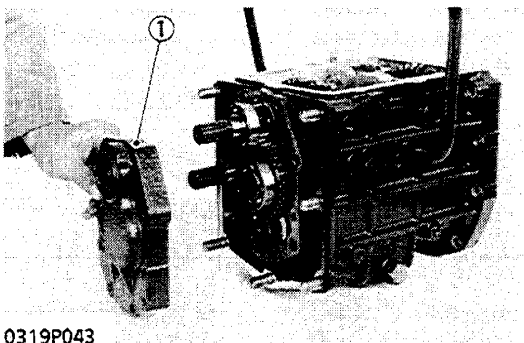

0319P043

Shaft Cover 1

1. Remove the shaft cover 1 (1).

(When reassembling)

- Be sure to replace the gasket (2) with a new one.

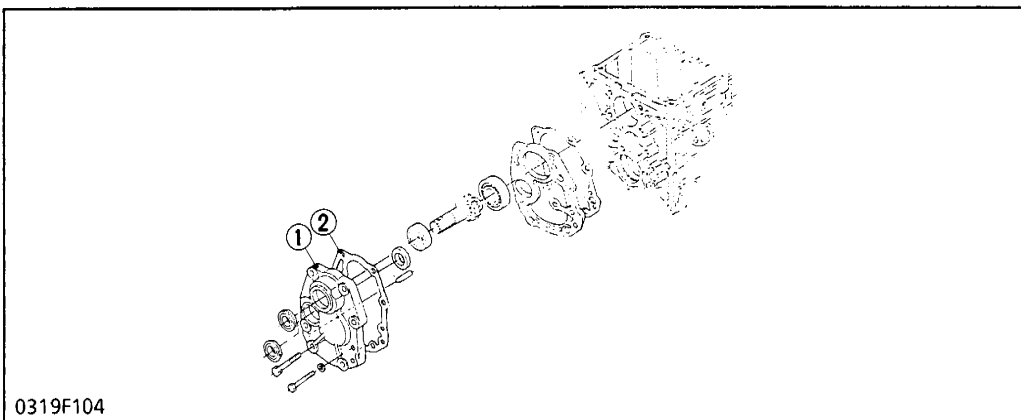

0319F104

- (1) Shaft Cover
- (2) Gasket

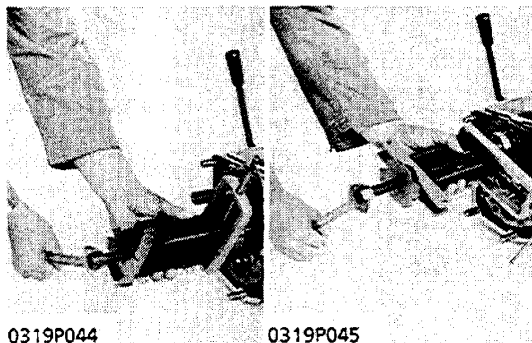

1st Shaft

1. Remove the bearing (1) on the 1st shaft (2) with a special-use puller set (Code No: 07916-09032).
2. Remove the bearing (4) and 29T gear (6) on the 2nd shaft (5) with a special-use puller set.
3. Remove the 1st shaft with the cover spacer (7).

(When reassembling)

- Be sure to replace the gasket (8) with a new one.

0319P044

0319P045

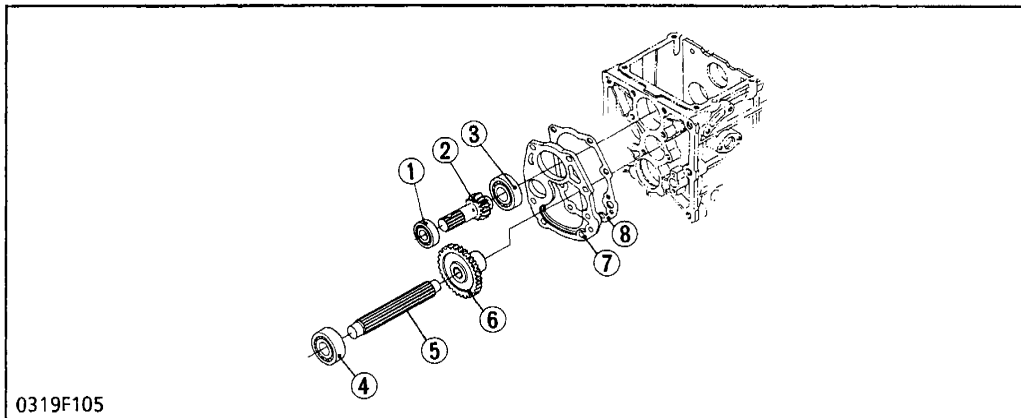

- (1) Bearing
- (2) 1st Shaft
- (3) Bearing
- (4) Bearing
- (5) 2nd Shaft
- (6) 29T Gear
- (7) Cover Spacer
- (8) Gasket

0319F105

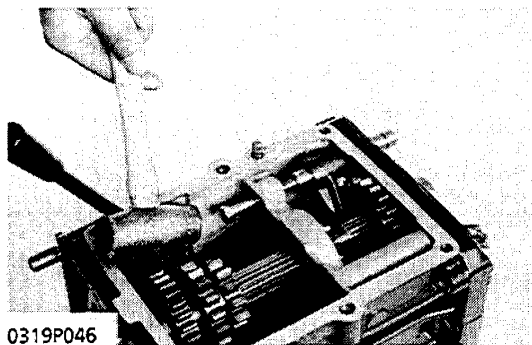

Fork Shaft and Shift Fork

1. Remove the shaft lock screw (1).
2. Screw M8 screw (pitch 1.25 x 70 mm long, pitch 1.25 x 2.76 in. long) into the fork shaft (3), and tap out it to the rear.
3. Remove the shift fork(2).

(When reassembling)

- Install the fork shaft with the groove (4) facing the differential gear case (5).

0319P046

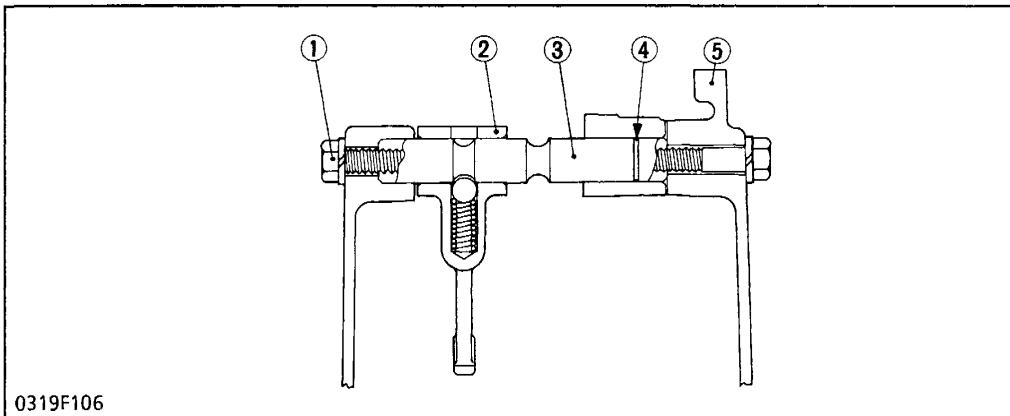

- (1) Fork Shaft Lock Screw
- (2) Shift Fork
- (3) Fork Shaft
- (4) Groove
- (5) Differential Gear Case

0319F106

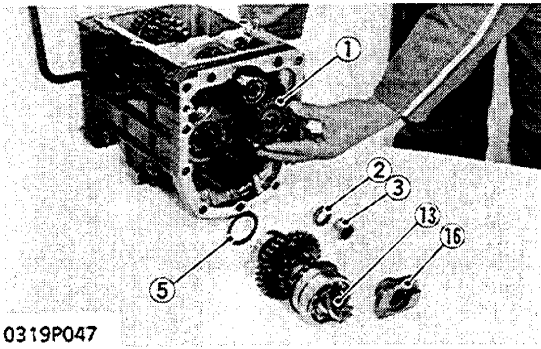

Spiral Bevel Pinion Shaft

1. Remove the rod and drum (16).
2. Draw out the spiral bevel pinion shaft (13).
3. Remove the 24T gear (1). (4WD type only)

0319P047

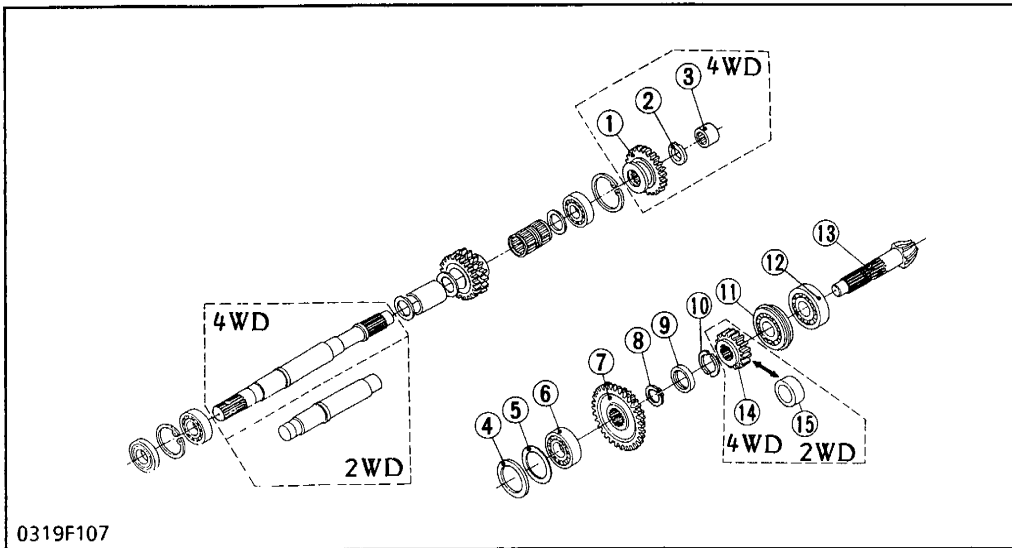

- (1) 24T gear
- (2) Collar
- (3) Needle Bearing
- (4) Spacer
- (5) Shim
- (6) Bearing
- (7) 13T-32T Gear
- (8) External Snap Ring
- (9) Collar
- (10) Stop Collar
- (11) Bearing
- (12) Bearing
- (13) Spiral Bevel Pinion Shaft
- (14) 16T Gear
- (15) Pinion Collar
- (16) Drum

0319F107

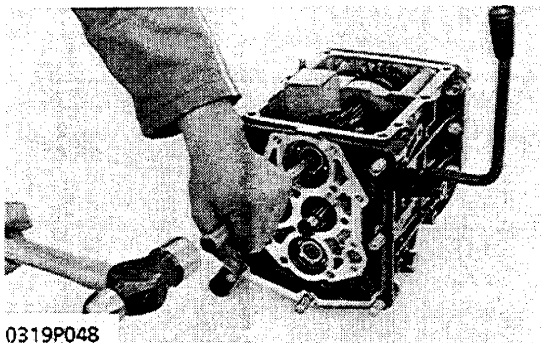

4th Shaft

1. Remove the external snap ring (6).
2. Set a wood piece, and tap out the 4th shaft (5) to the rear to remove the bearing (1).
3. Remove the 30T gear (2) and 13T-17T gear (3), and pull out the 4th shaft(5).

0319P048

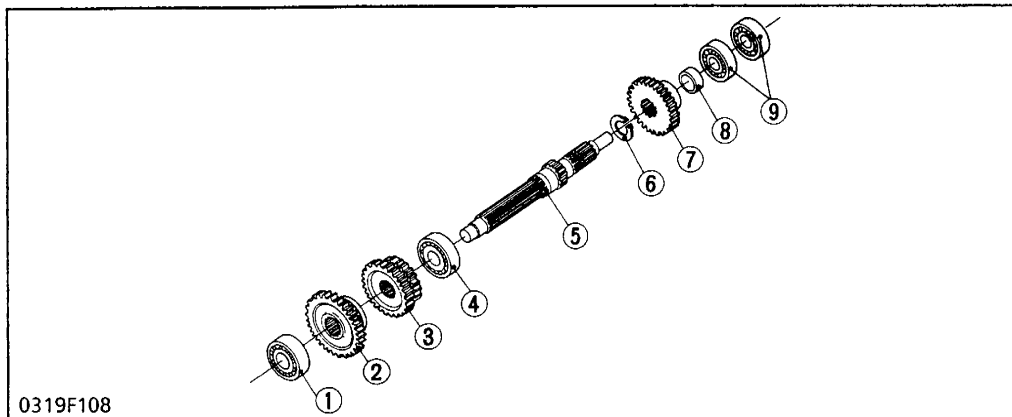

- (1) Bearing
- (2) 30T Gear
- (3) 13T-17T Gear
- (4) Bearing
- (5) 4th Shaft
- (6) External Snap Ring
- (7) 19T Gear
- (8) Collar
- (9) Bearing

0319F108

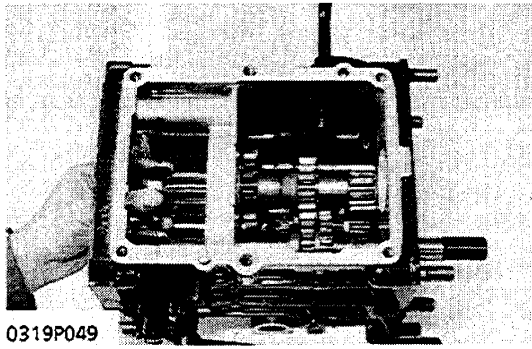

0319P049

2nd Shaft

1. Draw out the 2nd shaft (2) to the rear.

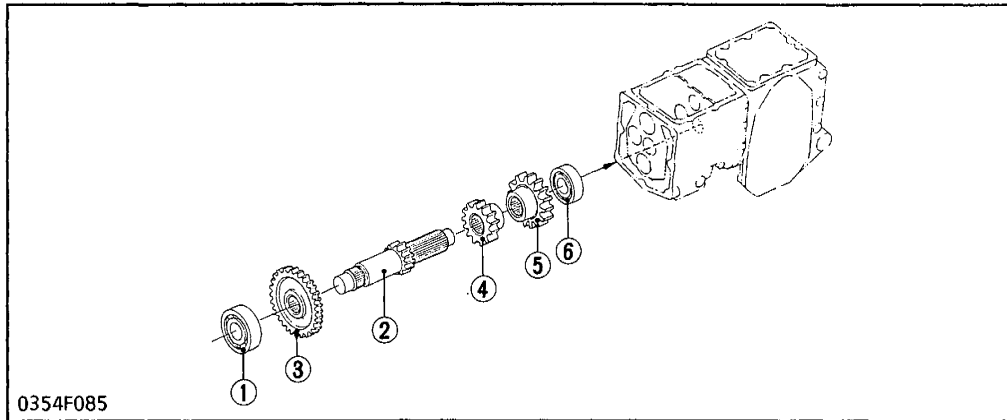

0354F085

- (1) Bearing
- (2) 2nd Shaft with 13T Gear
- (3) 29T Gear
- (4) 13T Gear
- (5) 17T Gear
- (6) Bearing

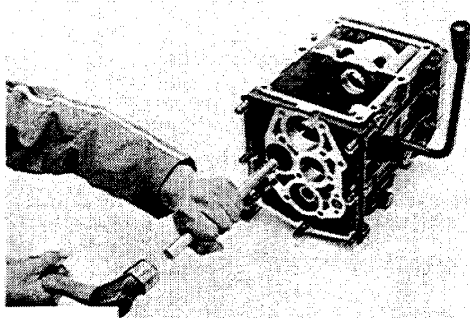

0319P050

Reverse Shaft

1. Remove the internal snap ring (8), and tap out the reverse shaft (3 or 10) to the rear.

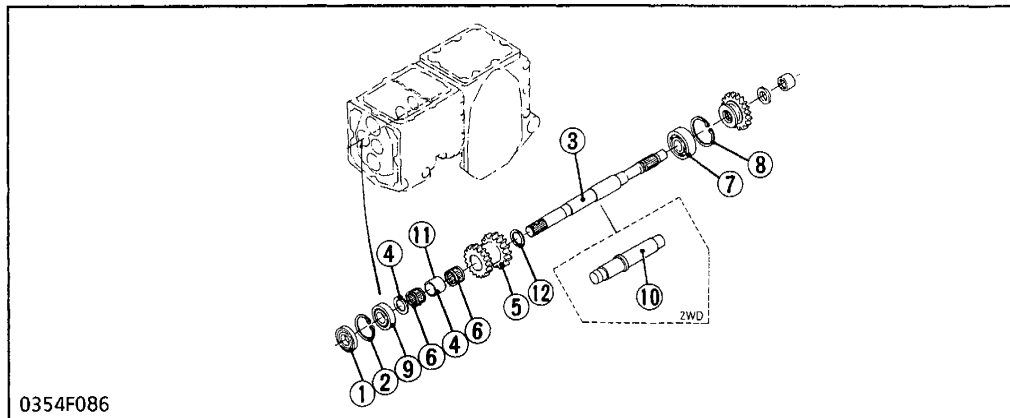

0354F086

- (1) Oil Seal
- (2) Internal Snap Ring
- (3) Reverse Shaft (4WD)
- (4) Collar
- (5) 16T-20T Gear
- (6) Needle Bearing
- (7) Bearing
- (8) Internal Snap Ring
- (9) Bearing
- (10) Reverse Shaft (2WD)
- (11) Collar 1
- (12) Collar

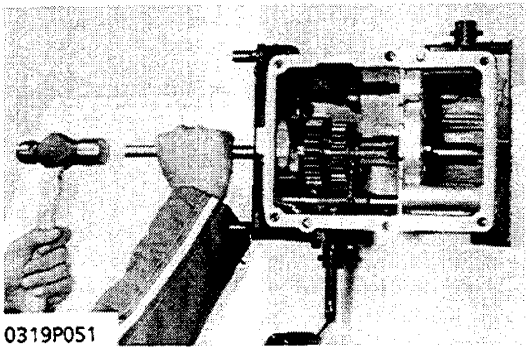

0319P051

3rd Shaft

1. Remove the internal snap ring (7).
2. Set a wood piece, and tap out the 3rd shaft (5) to the rear to remove the bearing (3).
3. Remove the 17T-13T gear (4) and pull out the 3rd shaft (5).

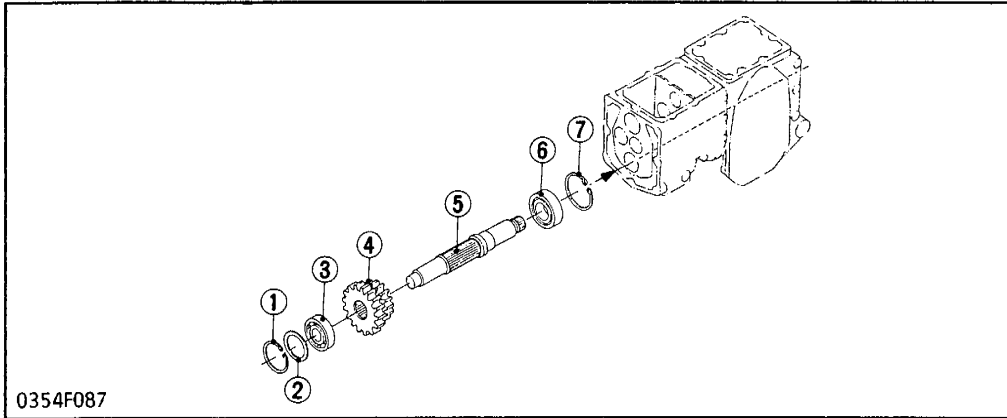

0354F087

- (1) Internal Snap Ring
- (2) Shim
- (3) Bearing
- (4) 17T-13T Gear
- (5) 3rd Shaft
- (6) Bearing
- (7) Internal Snap Ring

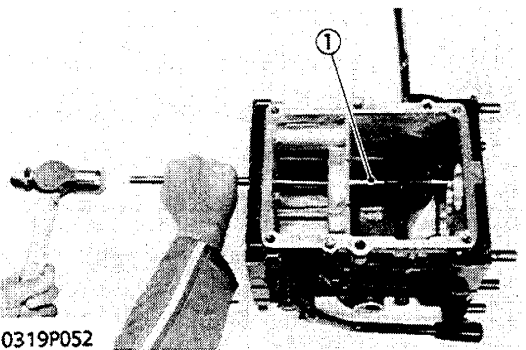

0319P052

PTO Fork Shaft

1. Tap out the PTO fork shaft (1) to the front.

Mid-PTO

Refer to page S.3-30.

The 19T Gear is used for the gear transmission instead of the 24T Gear.

SERVICING

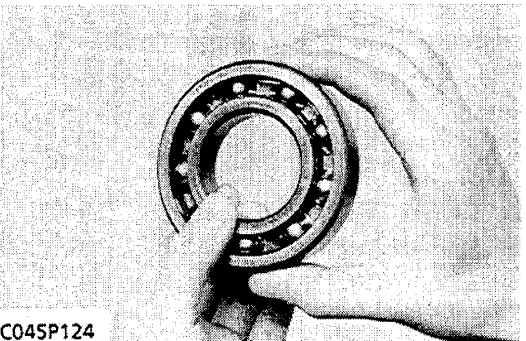

C045P124

Checking Bearing

1. Hold the inner race, and push and pull the outer race in all directions to check for wear and roughness.
2. Apply transmission oil to the bearing, and hold the inner race. Then, turn the outer race to check rotation.
3. If there is any defect, replace it.

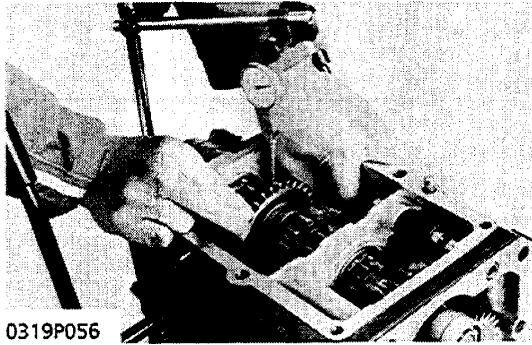

0319P056

Gear Backlash

1. Set a dial indicator (lever type) with its finger on the tooth surface.
2. Move the gear to measure the backlash, while holding the mating gear.
3. If the measurement exceeds the allowable limit, replace it.

Gear backlash	Factory spec.	0.10 to 0.20 mm 0.004 to 0.008 in.
	Allowable limit	0.4 mm 0.006 in.

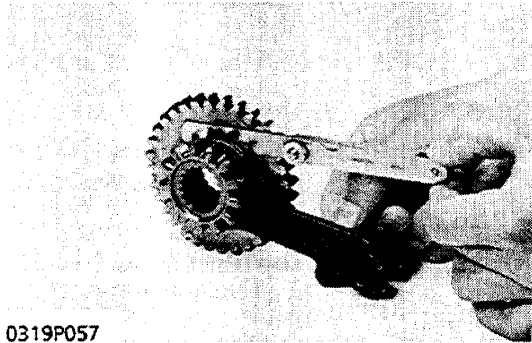

0319P057

Clearance between Shift Fork and Shift Gear Groove

1. Place the shift fork in the shift gear groove and measure the clearance with a feeler gauge.
2. If the clearance exceeds the allowable limit, replace it.

Clearance between shift fork and shift gear groove	Factory spec.	0.10 to 0.35 mm 0.004 to 0.014 in.
	Allowable limit	0.5 mm 0.020 in.

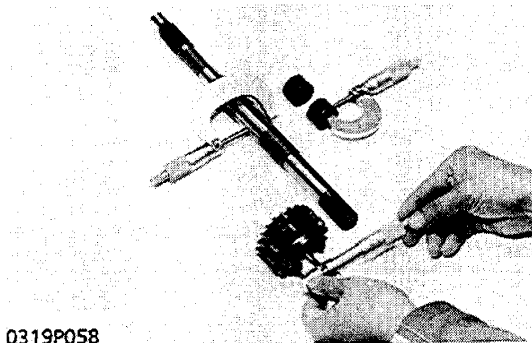

0319P058

Clearance between 16T-20T Gear and Reverse Shaft

1. Measure the 16T-20T gear I.D. with an inside micrometer, and then reverse shaft O.D. with an outside micrometer.
2. Measure the O.D. of two needles in the needle bearing with an outside micrometer.
3. Clearance is the difference between the gear I.D. and the sum of shaft O.D. and two needle O.D.
4. If the clearance exceeds the allowable limit, replace.

Clearance between 16T-20T gear and reverse shaft	Factory spec.	0.007 to 0.0045 mm 0.0003 to 0.0018 in.
	Allowable limit	0.1 mm 0.0039 in.

Reverse shaft O.D.	Factory spec.	21.967 to 21.980 mm 0.8648 to 0.8654 in.
16T-20T gear I.D.	Factory spec.	25.987 to 26.000 mm 1.0231 to 1.0236 in.
Needle O.D.	Factory spec.	1.994 to 2.000 mm 0.0785 to 0.0787 in.

[5] DIFFERENTIAL GEAR CASE DISASSEMBLING AND ASSEMBLING

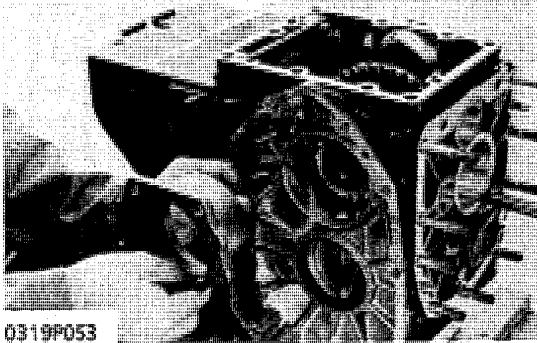

0319P053

Differential Assembly

1. Remove the left and right differential bearing holders (19), (9).
2. Take out the differential assembly from the differential gear case.

(When reassembling)

- Install the differential assembly, noting the number of differential side shims (10), (18).

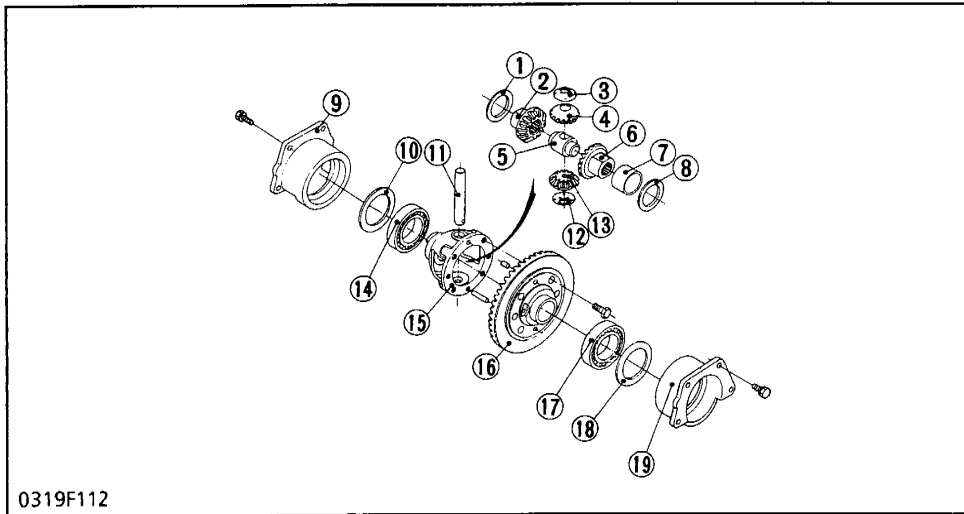

- (1) Shim
- (2) Differential Side Gear
- (3) Differential Pinion Collar
- (4) Differential Pinion
- (5) Thrust Collar
- (6) Differential Side Gear
- (7) Ring Gear Bushing
- (8) Shim
- (9) Differential Bearing Holder (RH)
- (10) Differential Side Shim
- (11) Differential Pinion Shaft
- (12) Differential Pinion Collar
- (13) Differential Pinion
- (14) Bearing
- (15) Differential Case
- (16) Ring Gear
- (17) Bearing
- (18) Differential Side Shim
- (19) Differential Bearing Holder (LH)

0319F112

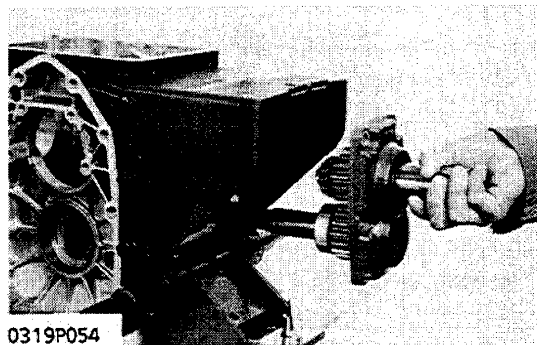

0319P054

5th Shaft

1. Remove the external snap ring (1), and remove the drum (2) and spring (3). (B1550-B1750)
2. Remove the rear cover mounting screws.
3. Remove the 5th shaft (5) with the PTO shaft.

Tightening torque	Rear cover mounting screw	39.2 to 64.7 N·m 4.0 to 6.6 kgf·m 28.9 to 47.7 ft·lbs
-------------------	---------------------------	---

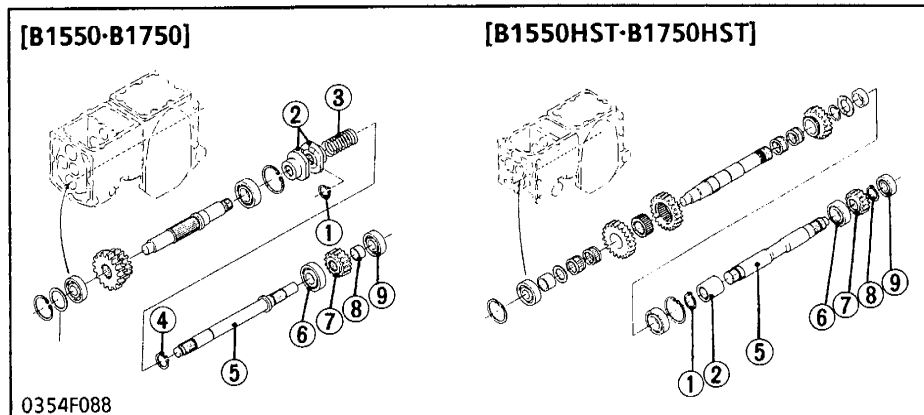

- (1) External Snap Ring
- (2) Coupling (B1550HST-B1750HST)
- (2) One way Clutch Cam (B1550-B1750)
- (3) Spring (B1550-B1750)
- (4) External Snap Ring (B1550-B1750)
- (5) 5th Shaft
- (6) Bearing
- (7) 14T Gear (B1550HST-B1750HST)
- (7) 13T Gear (B1550-B1750)
- (8) External Snap Ring (B1550HST-B1750HST)
- (8) Collar (B1550-B1750)
- (9) Bearing

0354F088

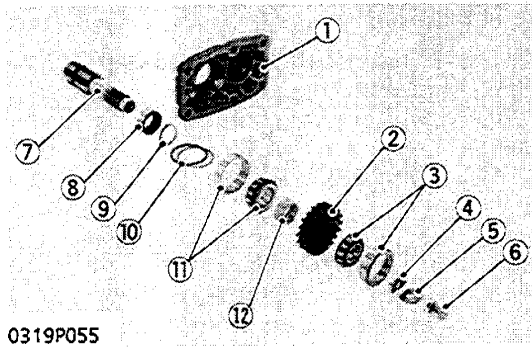

PTO Shaft

1. Flatten the lock washer (5).
2. Remove the screw (6), plain washer, lock washer (5), washer (4) and straight pin.
3. Tap out the PTO shaft (7) to the rear.

(When reassembling)

- Replace the lock washer with a new one, be sure to adjust the turning torque of PTO shaft. (See page S.3-40)
- Lock the screw with the lock washer after adjusting the turning torque.

Tightening torque	Screw	18.6 to 32.4 N·m 1.9 to 3.3 kgf·m 13.7 to 23.9 ft-lbs
-------------------	-------	---

- | | |
|----------------------------------|---------------------------|
| (1) Rear Cover | (7) PTO Shaft |
| (2) 21T Gear (B1550HST-B1750HST) | (8) Bushing |
| (2) 22T Gear (B1550-B1750) | (9) PTO Collar |
| (3) Taper Roller Bearing | (10) PTO Shim |
| (4) Washer | (11) Taper Roller Bearing |
| (5) Lock Washer | (12) PTO Collar |
| (6) Screw | |

SERVICING

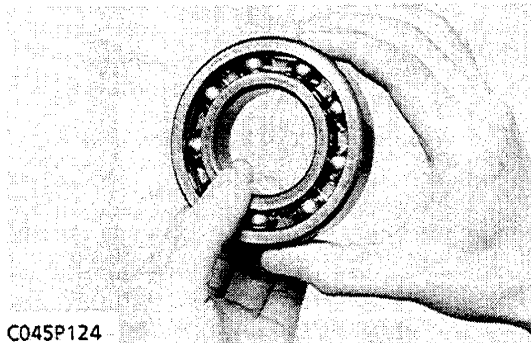

Checking Bearing

1. Hold the inner race, and push and pull the outer race in all directions to check for wear and roughness.
2. Apply transmission oil to the bearing, and hold the inner race. Then, turn the outer race to check rotation.
3. If there is any defect, replace it.

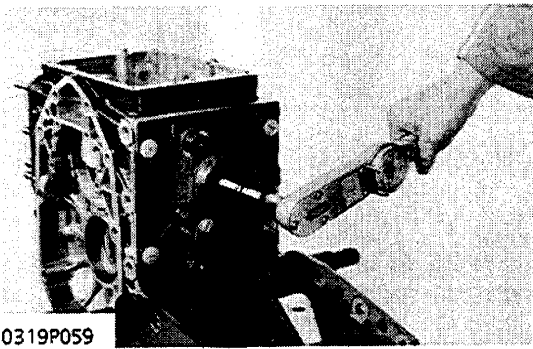

0319P059

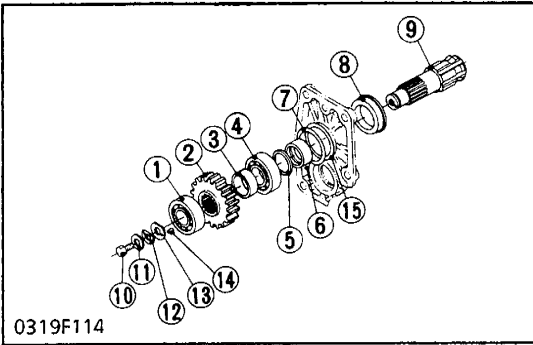

0319F114

Initial Turning Torque of PTO Shaft

1. Tighten the screw (10) to the specified torque (18.6 to 32.4 N·m, 1.9 to 3.3 kgf·m, 13.7 to 23.9 ft-lbs).
2. Install the PTO shaft to the rear cover, and install it to the differential gear case.
3. Screw the screw (M 10 x Pitch 1.25) in PTO shaft (9), and set a torque wrench to it.
4. Turn the PTO shaft with a torque wrench to measure the initial turning torque.
5. If the initial turning torque is not within the factory specifications, adjust the turning torque with the shims (15).

Initial turning torque	Factory spec.	0.49 to 1.47 N·m 0.05 to 0.15 kgf·m 0.36 to 1.08 ft-lbs
------------------------	---------------	---

(Reference)

- Thickness of shims: 0.3 mm (0.012 in.)
0.4 mm (0.016 in.)
0.5 mm (0.020 in.)

NOTE

- Lock the screw (10) with the lock washer (12) after adjusting the turning torque.

- | | |
|----------------------------------|-------------------|
| (1) Taper Roller Bearing | (8) Oil Seal |
| (2) 21T Gear (B1550HST-B1750HST) | (9) PTO Shaft |
| (3) PTO Collar | (10) Screw |
| (4) Taper Roller Bearing | (11) Plain Washer |
| (5) PTO Collar | (12) Lock Washer |
| (6) Bushing | (13) Washer |
| (7) PTO Bearing Collar | (14) Straight Pin |
| | (15) Shim |

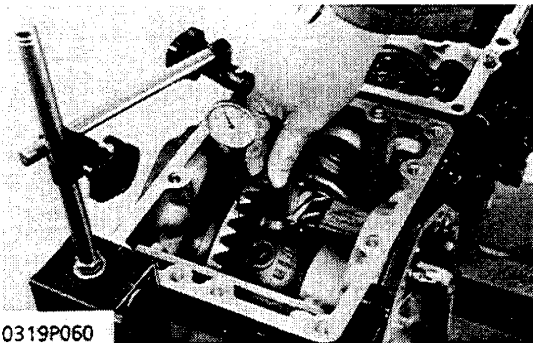

0319P060

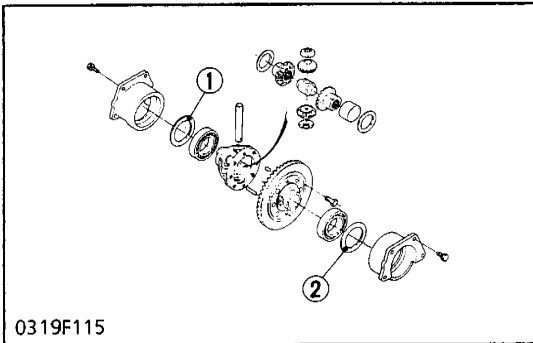

0319F115

- (1) Shim
- (2) Shim

Backlash between Ring Gear and Spiral Bevel Pinion Shaft

1. Set a dial indicator (lever type) on the ring gear.
2. Measure the backlash by fixing the spiral bevel pinion shaft and moving the ring gear by hand.
3. When the backlash is too small, decrease the number of shims (2) in the side of the ring gear, and insert the removed shims in the opposite side. When the backlash is too large, decrease the number of shims (1) in the side of the differential case, and insert the removed shims in the opposite side.
4. Adjust the backlash properly by repeating the above procedure.

Backlash between ring gear and spiral bevel pinion shaft	Factory spec.	0.1 to 0.2 mm 0.004 to 0.008 in.
	Allowable limit	0.4 mm 0.016 in.

(Reference)

- Thickness of differential side shims (1) : 0.2 mm (0.008 in.)
0.3 mm (0.012 in.)
0.5 mm (0.020 in.)
- Thickness of differential side shims (2) : 0.2 mm (0.008 in.)
0.3 mm (0.012 in.)
0.5 mm (0.020 in.)

[B2150-B2150HST] TROUBLESHOOTING

■ HYDROSTATIC TRANSMISSION [B2150HST]

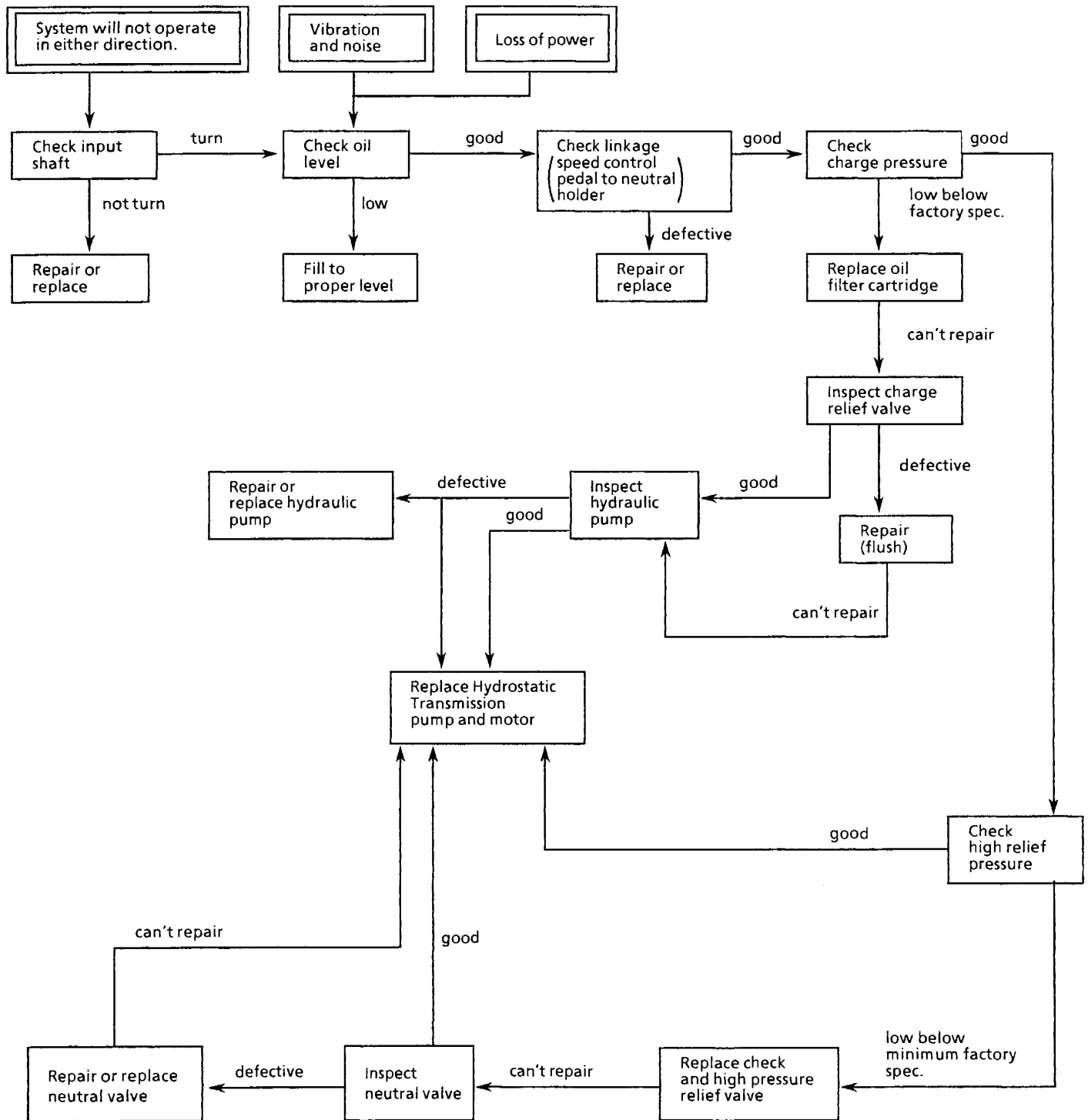

■ HYDROSTATIC TRANSMISSION (Continued)

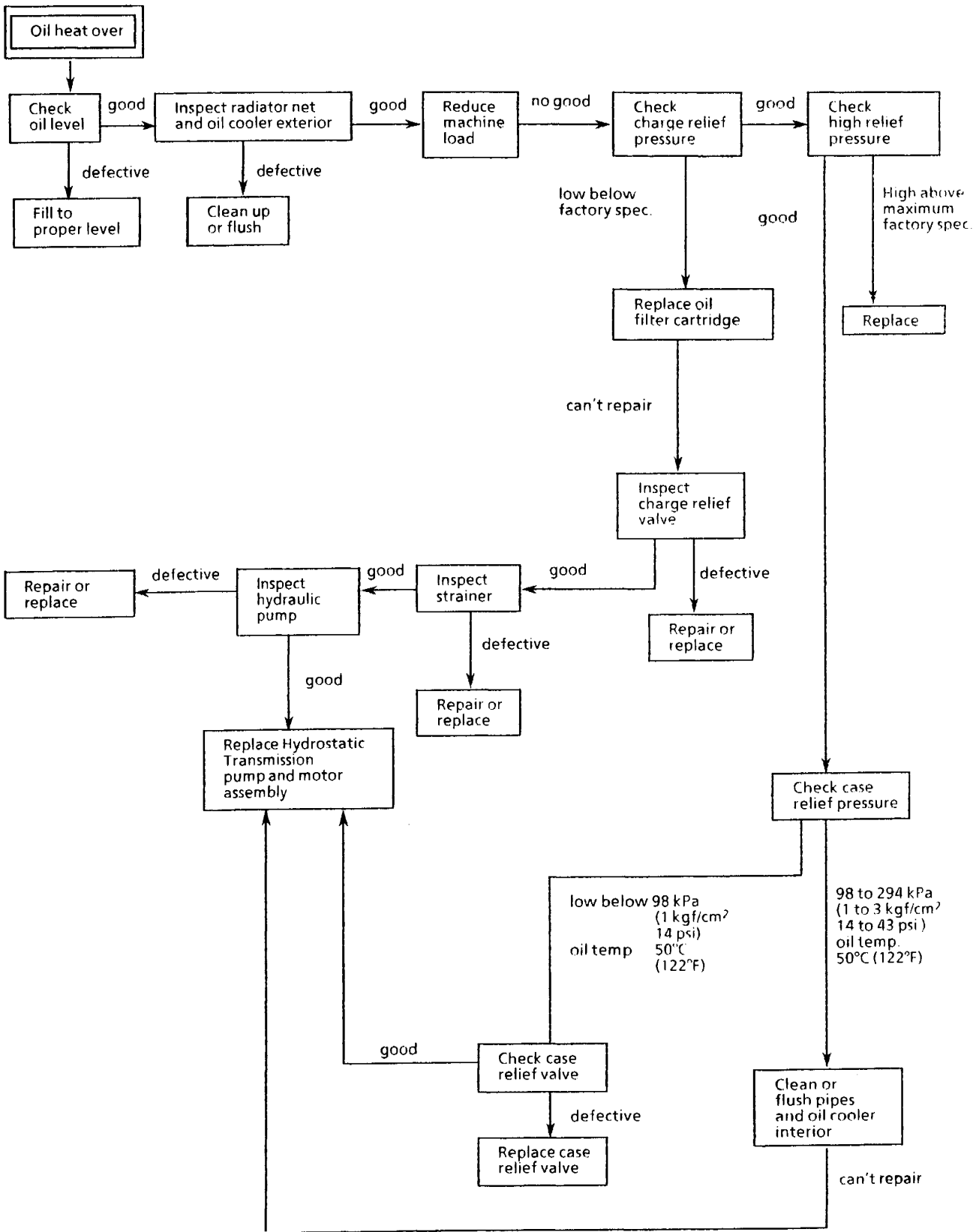

TROUBLESHOOTING

MECHANICAL TRANSMISSION [B2150]

Symptom	Probable Cause	Solution	Reference Page
Noise from Transmission	<ul style="list-style-type: none"> ● Transmission oil insufficient ● Gear worn or broken ● Improper backlash between spiral bevel pinion and spiral bevel gear ● Improper backlash between differential pinion and differential side gear ● Bearings worn 	Refill Replace Adjust Adjust Replace	S.G-8 — S.3-71 S.4-5 S.3-67
Gear Slip Out of Mesh	<ul style="list-style-type: none"> ● Shift fork spring tension insufficient ● Shift fork or shifter worn ● Shift fork bent 	Replace Replace Replace	— S.3-68 S.3-68
Hard Shifting	<ul style="list-style-type: none"> ● Shifter or shift fork worn or damaged ● Shift fork bent 	Replace Replace	S.3-68 S.3-68
Gears Clash When Shifting	<ul style="list-style-type: none"> ● Clutch does not release 	Adjust or Repair	S.2-9

SERVICING SPECIFICATIONS

Item	Factory Specification	Allowable Limit	
Case Relief Valve	Setting Pressure	98 to 294 kPa 1 to 3 kgf/cm ² 14 to 43 psi (Oil temperature at 50°C, 122°F)	—
	Spring Length	(free) 23.0 mm 0.906 in. load 29.4 N, 3.0 kgf, 6.6 lbs 15.0 mm 0.591 in.	— —
Check and High Pressure Relief Valve	Setting Pressure [Relief Valve]	27.5 to 28.4 MPa 280 to 290 kgf/cm ² 3983 to 4125 psi (Oil temperature at 50°C, 122°F)	—
	Spring Length(short) [Relief Valve]	(free) 12.4 mm 0.488 in. load 41.84 N, 4.27 kgf, 9.41 lbs 10.5 mm 0.413 in.	— —
	Spring Length(long) [Check Valve]	(free) 18.2 mm 0.717 in. load 3.43 N, 0.35 kgf, 0.77 lbs 14.5 mm 0.571 in.	— —

SERVICING SPECIFICATIONS (Continued)

Item		Factory Specification	Allowable Limit
Neutral Valve	Setting Pressure	Close 2.45 to 3.73 MPa [25 to 38 kgf/cm ² , 356 to 540 psi] Open 1.47 MPa [15 kgf/cm ² , 213 psi] (Oil temperature at 50°C, 122°F)	—
	Spring Length (short)	(free) 18.4 mm 0.7244 in. load 43.2 N, 13.9 mm 4.4 kgf, 9.7 lbs 0.5472 in.	—
Charge Relief Valve	Setting Pressure	490 to 686 kPa 5 to 7 kgf/cm ² 71 to 99 psi (Oil temperature at 50°C, 122 °F)	—
	Spring Length	(free) 23 mm 0.91 in. load 27 N, 17 mm 2.7 kgf, 6.0 lbs 0.67 in.	—
Piston to Bore	Clearance	0.02 mm 0.0008 in.	0.04mm 0.0016 in.
Piston Slipper	Thickness	3.00 mm 0.118 in.	2.90 mm 0.1142 in.

SERVICING SPECIFICATIONS

Item		Factory Specification	Allowable Limit
Gear to Spline	Backlash	0.030 to 0.078 mm 0.001 to 0.003 in.	0.2 mm 0.008 in.
Gear to Gear	Backlash	0.10 to 0.20 mm 0.004 to 0.008 in.	0.4 mm 0.016 in.
24T Gear to PTO Shift Fork (B2150HST)	Clearance	0.10 to 0.30 mm 0.004 to 0.012 in.	0.5 mm 0.020 in.
16T-29T Gear to Shift Fork (B2150HST)	Clearance	0.10 to 0.35 mm 0.004 to 0.014 in.	0.5mm 0.020 in.
Shifter to Shift Fork (B2150HST)	Clearance	0.10 to 0.35 mm 0.004 to 0.014 in.	0.5mm 0.020 in.
18T Gear to 3rd Shaft (B2150HST)	Clearance	0.009 to 0.059 mm 0.0004 to 0.0023 in.	0.10 mm 0.0039 in.
3rd Shaft	O.D.	27.987 to 28.000 mm 1.1019 to 1.1024 in.	—
18T Gear	I.D.	32.009 to 32.034 mm 1.2602 to 1.2612 in.	—
Needle	O.D.	1.994 to 2.000 mm 0.0785 to 0.0787 in.	—
12T Gear to 3rd Shaft (B2150HST)	Clearance	0.007 to 0.053 mm 0.0003 to 0.0021 in.	0.10 mm 0.0039 in.
3rd Shaft	O.D.	21.987 to 22.000 mm 0.8657 to 0.8661 in.	—
12T Gear	I.D.	27.007 to 27.028 mm 1.0633 to 1.0641 in.	—
Needle	O.D.	2.494 to 2.500 mm 0.0982 to 0.0984 in.	—
27T Gear to 6th Shaft (B2150HST)	Clearance	0.009 to 0.059 mm 0.0004 to 0.0023 in.	0.10 mm 0.0039 in.
6th Shaft	O.D.	27.987 to 28.000 mm 1.1019 to 1.1024 in.	—
27T Gear	I.D.	32.009 to 32.034 mm 1.2602 to 1.2612 in.	—
Needle	O.D.	1.994 to 2.000 mm 0.0785 to 0.0787 in.	—
32T Gear to Shift Fork (B2150)	Clearance	0.10 to 0.35 mm 0.004 to 0.014 in.	0.5 mm 0.020 in.
24T Gear to Shift Fork (B2150)	Clearance	0.10 to 0.30 mm 0.004 to 0.02 in.	0.5 mm 0.020 in.
Shifter to Shift Fork (B2150)	Clearance	0.10 to 0.35 mm 0.004 to 0.014 in.	0.5 mm 0.020 in.

SERVICING SPECIFICATIONS (Continued)

Item		Factory Specification	Allowable Limit
29T-15T Gear to Shift Fork (B2150)	Clearance	0.10 to 0.35 mm 0.004 to 0.014 in.	0.5 mm 0.008 in.
17T Gear to PTO Shift Fork (B2150)	Clearance	0.10 to 0.35 mm 0.004 to 0.014 in.	0.5 mm 0.020 in.
27T Gear to Front Drive Shift Fork (B2150)	Clearance	0.10 to 0.35 mm 0.004 to 0.014 in.	0.5 mm 0.020 in.
15T Shaft Gear to 1st Shaft (B2150)	Clearance	0.014 to 0.052 mm 0.0006 to 0.0020 in.	0.10 mm 0.0039 in.
1st Shaft	O.D.	19.980 to 19.993 mm 0.7866 to 0.7871 in.	—
15T Shaft Gear	I.D.	26.007 to 26.020 mm 1.0239 to 1.0244 in.	—
Needle	O.D.	2.994 to 3.000 mm 0.1179 to 0.1181 in.	—
20T Gear to 2nd Shaft (B2150)	Clearance	0.009 to 0.059 mm 0.0004 to 0.0023 in.	0.10 mm 0.0039 in.
2nd Shaft	O.D.	27.987 to 28.000 mm 1.1019 to 1.1024 in.	—
20T Gear	I.D.	32.009 to 32.034 mm 1.2602 to 1.2612 in.	—
Needle	O.D.	1.994 to 2.000 mm 0.0785 to 0.0787 in.	—
18T Gear to 3rd Shaft (B2150)	Clearance	0.009 to 0.059 mm 0.0004 to 0.0023 in.	0.10 mm 0.0039 in.
3rd Shaft	O.D.	27.987 to 28.000 mm 1.1019 to 1.1024 in.	—
18T Gear	I.D.	32.009 to 32.034 mm 1.2602 to 1.2612 in.	—
Needle	O.D.	1.994 to 2.000 mm 0.0785 to 0.0787 in.	—
13T Gear to 3rd Shaft (B2150)	Clearance	0.007 to 0.053 mm 0.0003 to 0.0021 in.	0.10 mm 0.0039 in.
3rd Shaft	O.D.	21.987 to 22.000 mm 0.8656 to 0.8661 in.	—
13T Gear	I.D.	27.007 to 27.028 mm 1.0633 to 1.0641 in.	—
Needle	O.D.	2.494 to 2.500 mm 0.0982 to 0.0984 in.	—

SERVICING SPECIFICATIONS (Continued)

Item		Factory Specification	Allowable Limit
27T Gear to Idle Shaft (B2150)	Clearance	0.007 to 0.053 mm 0.0003 to 0.0021 in.	0.10 mm 0.0039 in.
Idle Shaft	O.D.	21.987 to 22.000 mm 0.8656 to 0.8661 in.	—
27T Gear	I.D.	32.007 to 32.028 mm 1.2601 to 1.2609 in.	—
Needle	O.D.	4.994 to 5.000 mm 0.1966 to 0.1969 in.	—
16T-16T Gear to Reverse Shaft (B2150)	Clearance	0.007 to 0.045 mm 0.0003 to 0.0018 in.	0.10 mm 0.0039 in.
Reverse Shaft	O.D.	24.987 to 25.000 mm 0.9837 to 0.9843 in.	—
16T-16T Gear	I.D.	30.007 to 30.020 mm 1.1814 to 1.1819 in.	—
Needle	O.D.	2.494 to 2.500 mm 0.0982 to 0.0984 in.	—
Spiral Bevel Pinion Shaft	Turning Torque	0.98 to 4.90 N.m 0.10 to 0.50 kgf.m 0.22 to 1.10 ft-lbs	—
Spiral Bevel Pinion to Spiral Bevel Gear	Backlash	0.10 to 0.20 mm 0.0039 to 0.0080 in.	—

TIGHTENING TORQUES

Tightening torques of screws and nuts on the table below are especially specified.
(For general use screws and nuts : see page S.G-4)

Item	N·m	kgf·m	ft-lbs
Neutral adjuster mounting screw	23.5 to 27.4	2.4 to 2.8	17.4 to 20.2
Neutral holder arm mounting screw	23.5 to 27.4	2.4 to 2.8	17.4 to 20.2
Port block mounting screw	30.9 to 37.7	3.15 to 3.85	22.78 to 27.85
Cover mounting screw	3.5 to 4.3	0.36 to 0.44	2.60 to 3.18
Check and high pressure relief valve cap nut	53.9 to 63.7	5.5 to 6.5	39.8 to 47.0
Neutral valve	53.9 to 63.7	5.5 to 6.5	39.8 to 47.0
Charge relief valve	9.8 to 11.8	1.0 to 1.2	7.2 to 8.7
Front case cover mounting screw	34.3 to 39.2	3.5 to 4.0	25.3 to 28.9
Front cover mounting screw	34.3 to 39.2	3.5 to 4.0	25.3 to 28.9
Bearing support mounting screw and nut	16.7 to 19.6	1.7 to 2.0	12.3 to 14.5
Bearing holder mounting screw	16.7 to 19.6	1.7 to 2.0	12.3 to 14.5
Differential bearing holder mounting screw	17.6 to 23.5	1.8 to 2.4	13.0 to 17.4
Rear cover mounting screw	48.1 to 55.9	4.9 to 5.7	35.4 to 41.2

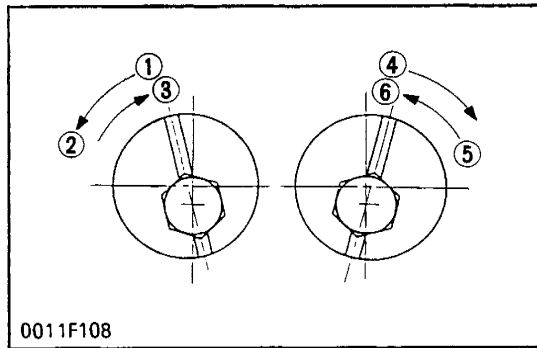
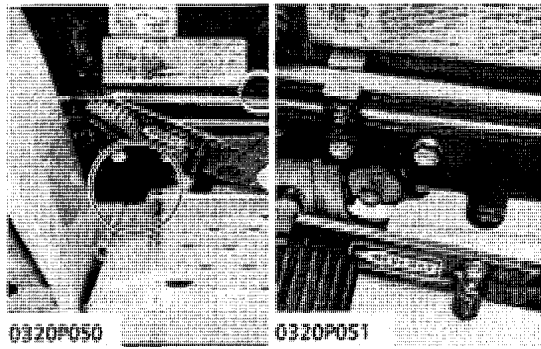

Adjusting Neutral

CAUTION

- When attempting to adjust the neutral, lift up the rear of the tractor with a jack to leave the rear wheels from the ground.
1. Rotate the neutral adjuster counterclockwise so the rear wheels turn forward.
 2. Then rotate it clockwise until wheels stop completely.
 3. Put a mark on the clutch housing aligning the groove on neutral adjuster.
 4. Rotate the neutral adjuster clockwise so the rear wheels turn reverse.
 5. Then rotate it counterclockwise until wheels stop completely.
 6. Put a mark on the clutch housing aligning the groove on neutral adjuster.
 7. Hold the neutral adjuster so its groove is at the middle of the marks and tighten the screw.

■ NOTE

- When the wheels tend to turn forward, rotate neutral adjuster clockwise.
- When the wheels tend to turn reverse, rotate neutral adjuster counterclockwise.

Tightening torque	Neutral adjuster to case	23.5 to 27.4 N·m 2.4 to 2.8 kgf·m 17.4 to 20.2 ft·lbs
-------------------	--------------------------	---

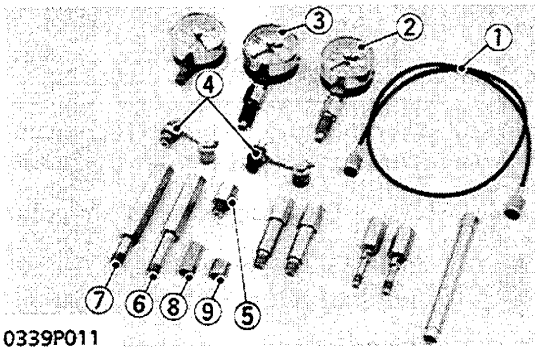

0339P011

- (1) HN Tube
- (2) High Pressure Gauge
- (3) Low Pressure Gauge
- (4) Connector 3
- (5) Adaptor 1
- (6) Adaptor 3
- (7) Adaptor 2
- (8) Collar
- (9) Collar

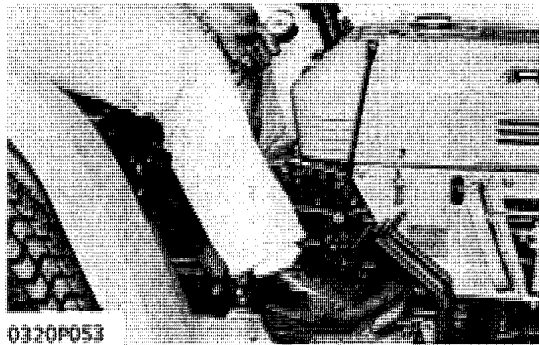

0320P053

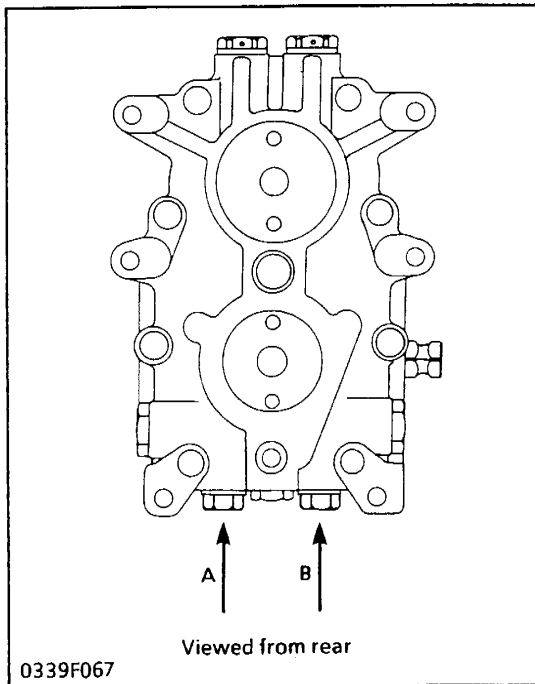

0339F067

High Relief Pressure and Charge Relief Pressure

1. Remove the joint screw LH and seal washer from the "A" port.
2. Attach adaptor 3 (6) with collar (8) and seal washer to the "A" port.
3. Remove the joint screw RH and seal washer from the "B" port.
4. Attach adaptor 2 (7) with the collar (9) and seal washer to the "B" port.
5. Attach the HN tube (1) and connector 3 (4) on adaptor 2 (7) and then a high pressure gauge (2) on the HN tube.
6. Attach the HN tube (1) and connector 3 (4) on adaptor 3 (6) and then a low pressure gauge (3) on the HN tube.
7. Fully engage parking brakes.
8. Change the range selector lever to the Low position.
9. Start the engine and run it at the maximum speed.
10. Read the low pressure gauge (3) (right side) to measure the charge relief pressure.
11. Then depress the speed control pedal forward and read the high pressure gauge (2) (left side) to measure the forward high relief pressure.
12. Stop the engine and interchange the high pressure gauge (2) with the low pressure gauge (3).
13. Start the engine and run it at the maximum speed.
14. Depress rear of the speed control pedal and read the high pressure gauge (2) (right side) to measure the reverse high relief pressure.
15. If the measurement is not within the factory specifications, replace the valve.
 When high relief pressure is defective, see page S.3-57 (Check and High Pressure Relief Valve).
 When charge relief pressure is defective, see page S.3-58 (Charge Relief Valve).

● **Factory Specification**

Charge relief valve	
Oil temperature	Valve operating pressure
50°C (122°F)	490 to 686 kPa (5 to 7 kgf/cm ² , 71 to 99 psi)

Check and high pressure relief valve	
Oil temperature	Valve operating pressure
50°C (122°F)	27.5 to 28.4 MPa (280 to 290 kgf/cm ² , 3982 to 4124 psi)

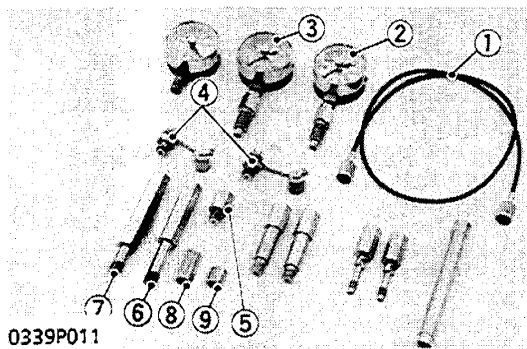

0339P011

- (1) HN Tube
- (2) High Pressure Gauge
- (3) Low Pressure Gauge
- (4) Connector 3
- (5) Adaptor 1
- (6) Adaptor 3
- (7) Adaptor 2
- (8) Collar
- (9) Collar

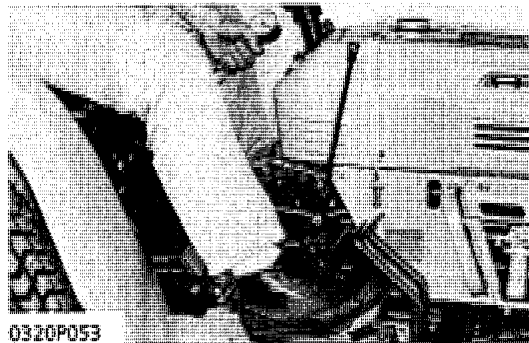

0320P053

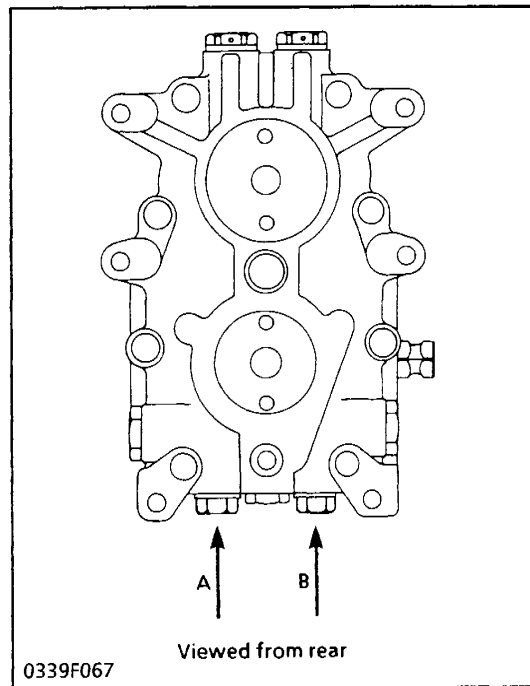

0339F067

Neutral Pressure

1. Remove the joint screw LH and seal washer from the "A" port.
2. Attach adaptor 2 (7) with the seal washer and collar (9) to the "A" port.
3. Remove the joint screw RH and seal washer from the "B" port.
4. Attach the adaptor 3 (6) with the seal washer and collar (8) to the "B" port.
5. Attach the connector 3's on both adaptors.
6. Attach the HN tube and low pressure gauge (3) on the connector 3 LH.
7. Change the range selector lever in to the Low position.
8. Start the engine and run it at low idling speed.
9. Slowly depress the front of the speed control pedal and read the low pressure gauge (3) when the tractor starts traveling (forward neutral valve closes).
10. Then slowly return the speed control pedal toward neutral position and read the gauge when the tractor stops traveling (forward neutral valve opens).
11. Stop the engine and attach the HN tube and Low pressure gauge (3) on the connector 3 RH.
12. Start the engine and run it at low idling speed.
13. Slowly depress the rear of the speed control pedal and repeat the above method (10. and 11.). Closing pressure and opening pressure of neutral valve RH (reverse) can be measured.
14. If the measurement is not nearly equal to the factory specification, replace the neutral valve.
See page S.3-57.

● Factory Specification

Neutral valve		
Oil temperature	Valve operating pressure	
50°C (122°F)	Close (start)	2.45 to 3.73 MPa 25 to 38 kgf/cm ² 356 to 540 psi
	Open (stop)	1.47 MPa 15 kgf/cm ² 213 psi

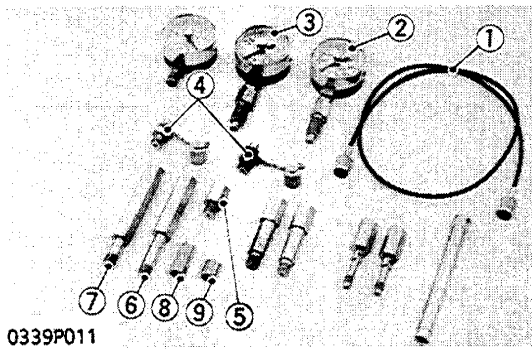

0339P011

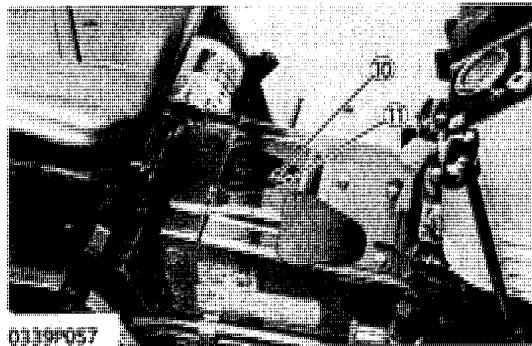

0339P057

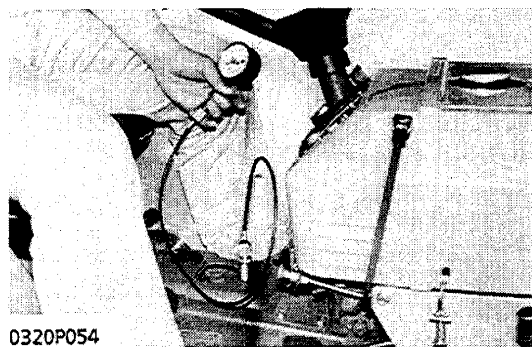

0320P054

Case Relief Pressure

1. Remove the plug (10) and O-ring from the joint bolt (11).
2. Install the O-ring on an adaptor 1 (5).
3. Attach adaptor 1 on the joint bolt (11).
4. Attach the HN tube (1) and connector 3 (4) on adaptor 1 (5).
5. Attach a low pressure gauge (3) on the HN tube.
6. Change the range selector lever to the neutral.
7. Start the engine and run it at the maximum speed.
8. Read the low pressure gauge to measure the case relief pressure.
9. If the measurement is not within the factory specifications replace the case relief valve.
See page S.3-58.

● **Factory Specification**

Case relief valve	
Oil temperature	Valve operating pressure
50°C (122°F)	98 to 294 kPa 1 to 3 kgf/cm ² 14 to 43 psi

- | | |
|-------------------------|-----------------|
| (1) HN Tube | (7) Adaptor 2 |
| (2) High Pressure Gauge | (8) Collar |
| (3) Low Pressure Gauge | (9) Collar |
| (4) Connector 3 | (10) Plug |
| (5) Adaptor 1 | (11) Joint Bolt |
| (6) Adaptor 3 | |

DISASSEMBLING AND ASSEMBLING

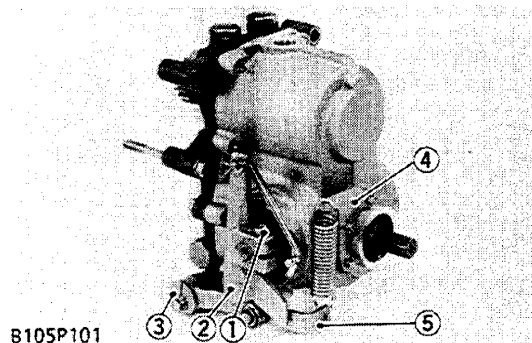

B105P101

Neutral Holder

1. Place parting marks on the neutral adjuster (3) and the neutral holder arm (5).
2. Remove the screws and spring holder (4).
3. Remove the screw and neutral holder arm (5).
4. Remove the screw (1) and pull out the neutral holder (2).

(When reassembling)

- Align the parting marks and install the neutral adjuster and the neutral holder arm.

Tightening torque	Neutral holder arm mounting screw	23.5 to 27.4 N·m 2.4 to 2.8 kgf·m 17.4 to 20.2 ft-lbs
-------------------	-----------------------------------	---

- | | |
|----------------------|------------------------|
| (1) Screw | (4) Spring Holder |
| (2) Neutral Holder | (5) Neutral Holder Arm |
| (3) Neutral Adjuster | |

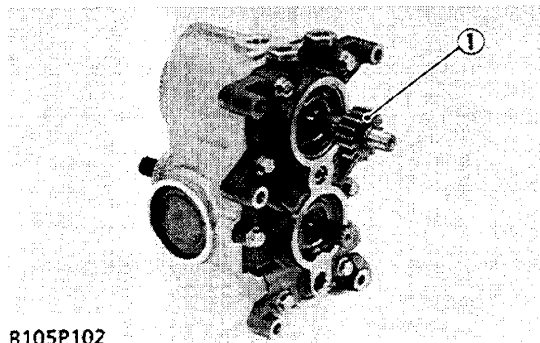

B105P102

17T Gear

1. Draw out the 17T gear (1).

(1) 17T Gear

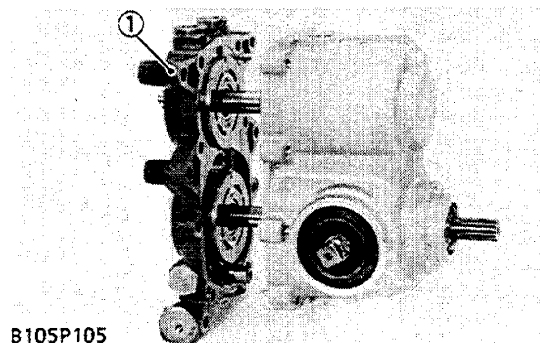

B105P105

Port Block

1. Remove the port block mounting screws, and tap the front of port block (1) flange with a soft hammer to separate.

(When reassembling)

- Cover the splines of each shaft with thin tape to protect sealing lip.
- Install port block with gasket, O-ring and valve plate in place.

■ IMPORTANT

- Valve plates (2), (3) may stick to the port block but they are not fixed. Take care not to drop them.
- Valve plates are not interchangeable. Valve plate of the pump has two notches and the one of motor has no.

Tightening torque	Port block to case	48.1 to 55.9 N·m 4.9 to 5.7 kgf·m 35.458 to 41.23 ft-lbs
-------------------	--------------------	--

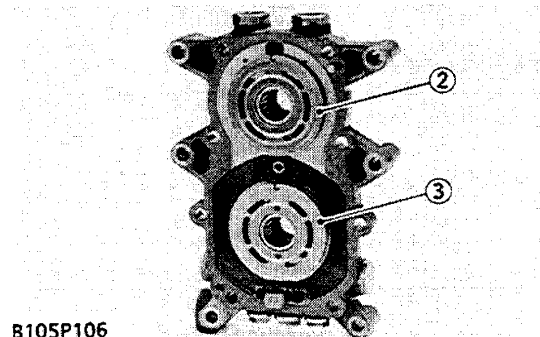

B105P106

(1) Port Block

(2) Valve Plate of Motor

(3) Valve Plate of Pump

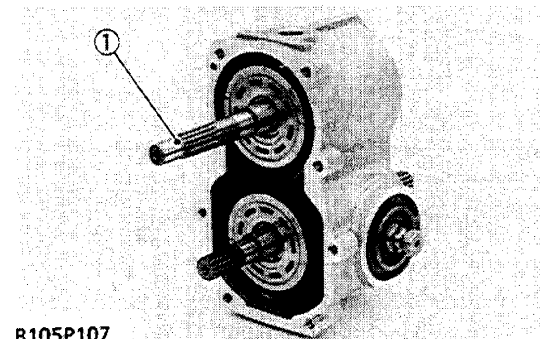

B105P107

Motor Cylinder Block

1. Hold the output shaft (1) and tap the rear of case flange with a soft hammer slightly to separate motor cylinder block assembly.
2. Remove internal snap ring (4) retaining retainer plate (5) of motor.
3. Slide out motor cylinder block (2) with pistons (3), retainer plate (5) and internal snap ring (4).

(When reassembling)

- Check that internal snap ring (4) faces correct direction, and install it to motor swashplate.
- Aligning the hole on swashplate to the dowel pin in the case, install output shaft assembly in the case.

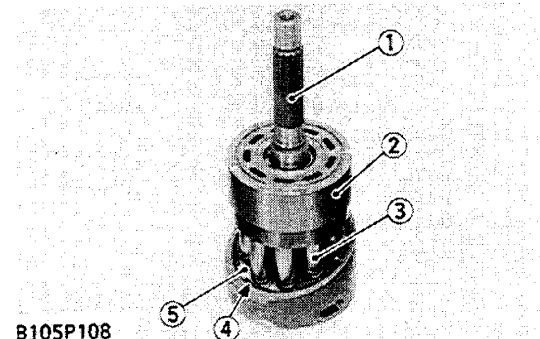

B105P108

(1) Output Shaft

(2) Motor Cylinder Block

(3) Piston

(4) Internal Snap Ring

(5) Retainer Plate

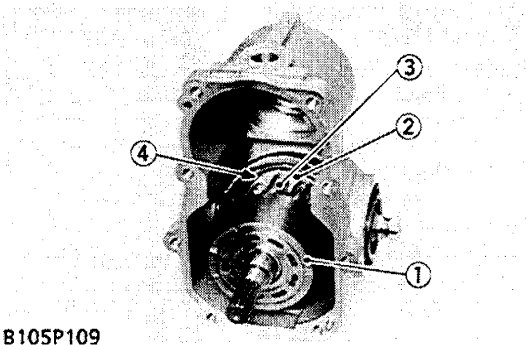

B105P109

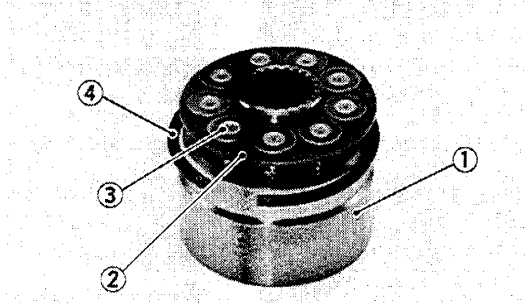

0320P062

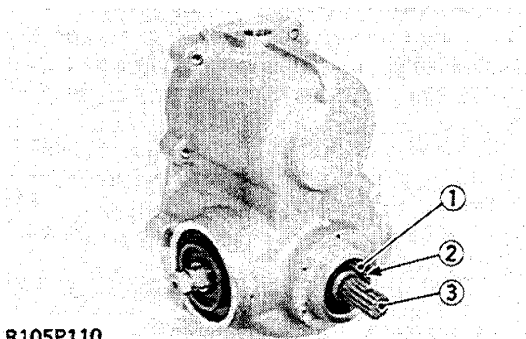

B105P110

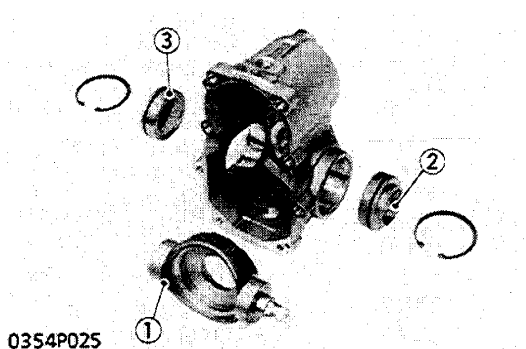

0354P025

Pump Cylinder Block

1. Remove internal snap ring (4) retaining the retainer plate (2) of pump.
2. Slide out pump cylinder block (1) with pistons (3) retainer plate (2) and internal snap ring (4).
3. Draw out the thrust plate from the variable swashplate.

(When reassembling)

- Check that internal snap ring (4) faces correct direction, and install it to pump swashplate.
- Squeeze the snap ring (4) and slip into the groove its arc first by pushing down with a screwdriver to fit surely.

- | | |
|-------------------------|------------------------|
| (1) Pump Cylinder Block | (3) Piston |
| (2) Retainer Plate | (4) Internal Snap Ring |

Input Shaft

1. Remove the internal snap ring (2).
2. Strike the end of the oil seal (1) at three positions using a screwdriver, break it open at one place, and pry it off with the screwdriver.
3. Tap out the input shaft (3).

- | | |
|------------------------|-----------------|
| (1) Oil Seal | (3) Input Shaft |
| (2) Internal Snap Ring | |

Cover "A", "B" and Trunnion Shaft

1. Remove the internal snap ring.
2. Tap the trunnion shaft (1) using a soft hammer to create a clearance between the case and the cover "A" (2). Then, pry the cover "A" (2) open with a screw-driver. Pry the cover "B" (3) in the same way.
3. Pull out the trunnion shaft (1).

- | | |
|--------------------|-------------|
| (1) Trunnion Shaft | (3) Cover B |
| (2) Cover A | |

SERVICING

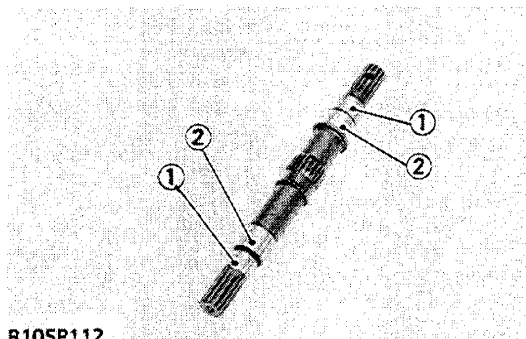

B105P112

Input Shaft

1. Pull out the input shaft from the case.
2. Check the seal surface (1), the bearing surface (2) and the bearing.
3. If the shaft is rough or grooved, replace.
4. If the bearing is worn, replace.

- | | |
|------------------|---------------------|
| (1) Seal Surface | (2) Bearing Surface |
|------------------|---------------------|

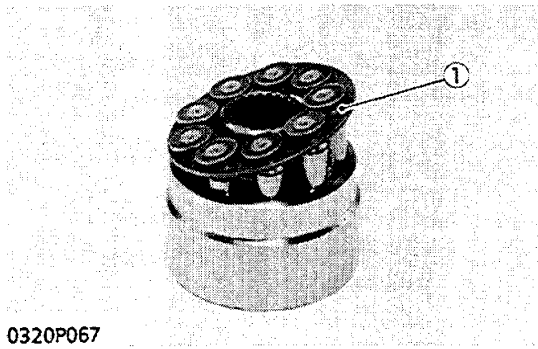

0320P067

(1) Retainer Plate

Cylinder Block Bore and Pistons

1. Lift all the pistons gently with the retainer plate (1).
2. Check the pistons for their free movement in the cylinder block bores.
3. If the piston or the cylinder block bore is scored, replace cylinder block assembly.

IMPORTANT

- Do not interchange pistons between pump and motor cylinder block. Pistons and cylinder blocks are matched.

Clearance between piston and bore	Factory spec.	0.02 mm 0.0008 in.
	Allowable limit	0.04 mm 0.0016 in.

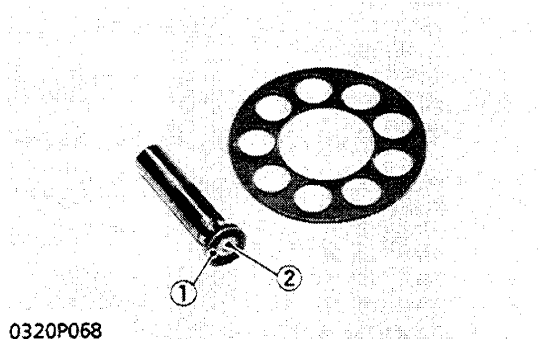

0320P068

Piston Slipper and Retainer Plate

1. Check the slipper (1) for flatness.
2. If rounded, replace.
3. Measure the thickness of piston slipper.
4. If the measurement is less than the allowable limit, replace.
5. Check the lubricant hole (2) for clogging.

IMPORTANT

- Do not interchange pistons between pump and motor cylinder block. Pistons and cylinder blocks are matched.

Thickness of slipper	Factory spec.	3.00 mm 0.118 in.
	Allowable limit	2.90 mm 0.114 in.

(1) Piston Slipper

(2) Lubricant Hole

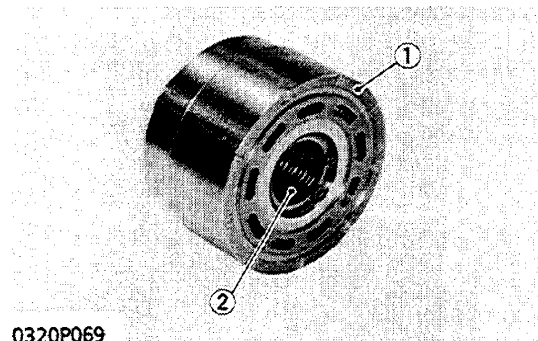

0320P069

Cylinder Block Face

1. Check the polished face (1) of cylinder block for scoring.
2. If scored, replace cylinder block assembly.
3. Check the spring (2) for breakage.
4. If broken, replace cylinder block assembly.

(1) Polished Face

(2) Spring

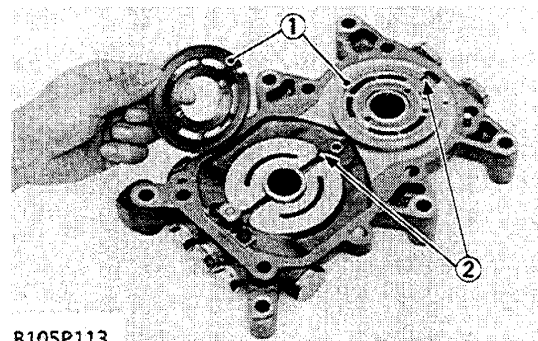

B105P113

Valve Plate

1. Check the engagement of the valve plate (1) and the anchor pin (2).
2. Pushing the valve plate against the anchor pin, lift it to remove.
3. Check the valve plate for foreign particles.
4. Clean the valve plate and dry with compressed air.
5. Check the valve plate for scratches, wear and erosion. (Run a finger nail across the valve plate surface. If worn, it will be felt.)
6. If worn or scored, replace.

NOTE

- After checking, coat them with hydrostatic transmission oil.

(1) Valve Plates

(2) Anchor Pin

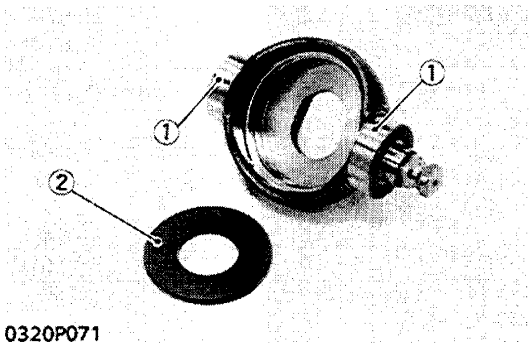

0320P071

Swashplate and Thrust Plate

1. Check the bearing surface (1) of trunnion shaft (swashplate) for scratches and excessive wear.
2. If worn or scored, replace.
3. Check the thrust plate (2) for scratches and excessive wear.
4. If worn or scored, replace.

(1) Bearing Surface

(2) Thrust Plate

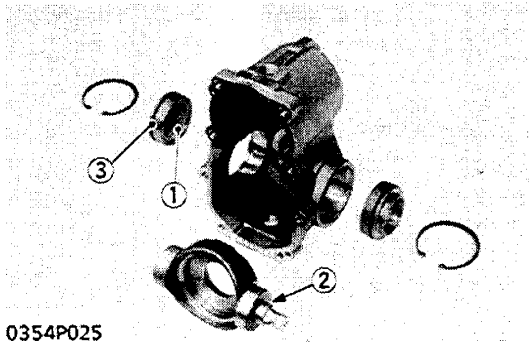

0354P025

Trunnion Shaft Cover

1. Check the bushings (1) for scratches and excessive wear.
2. If worn or scored, replace.
3. Check the oil seal (2) and the O-rings (3) for damage.

NOTE

- After checking, coat the bushings with hydrostatic transmission oil, and the oil seal lip and the O-rings (3) with grease.

(1) Bushings

(3) O-rings

(2) Oil Seal (Setting Location)

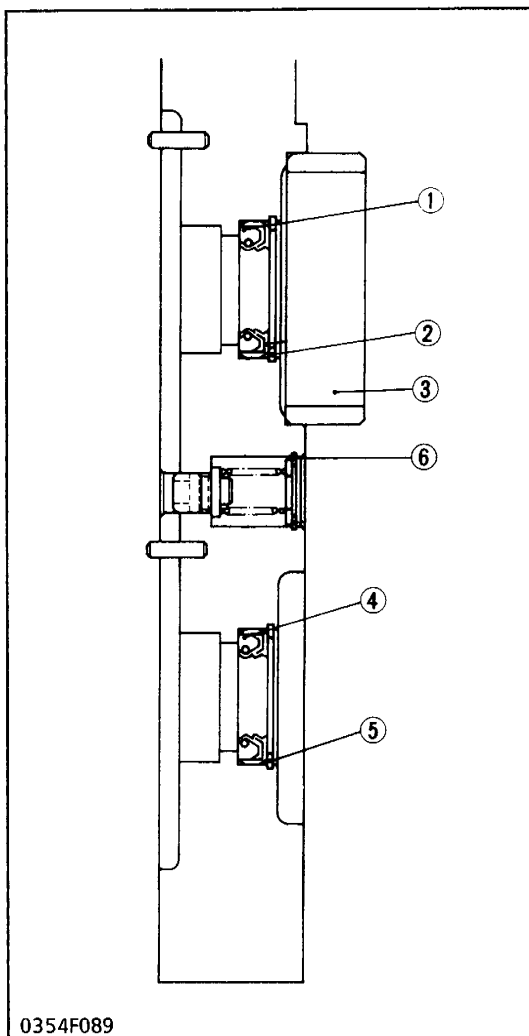

0354F089

Oil Seals and Bearings

1. Remove the collar (3) and internal snap ring (2), (5) and check the oil seals (1), (4) for damage.
2. Check the bearings (7) for wear.
3. If the bearings is worn, replace.

NOTE

- After checking, coat the bearing with hydrostatic transmission oil and the oil seal lip with grease.
- When replacing the bearing, press it in the port block so that its mark faces outside and 3.5 mm (0.138 in.) of it remains above the machined surface.
- When reassembling, always replace the oil seal with new.

(1) Oil Seal

(5) Internal Snap Ring

(2) Internal Snap Ring

(6) Internal Snap Ring

(3) Collar

(7) Needle Bearing

(4) Oil Seal

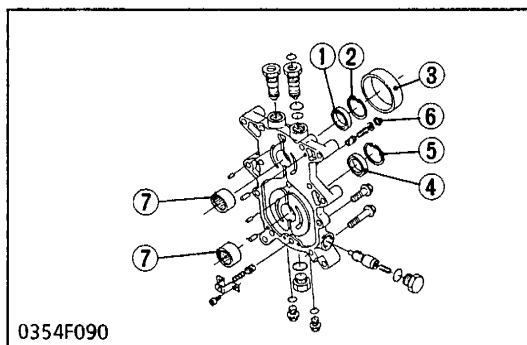

0354F090

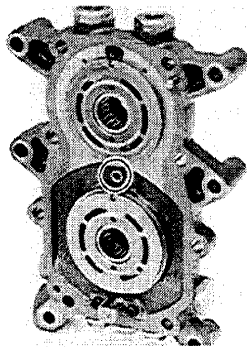

B105P114

Case Relief Valve

1. Check the valve and the spring for excessive wear and breakage.
2. If worn or broken, replace.

Length of valve spring	Factory spec.	23.0 mm (0.906 in.) (free)
		15.0 mm (0.591 in.) (load 29.4 N, 3.00 kgf, 6.62 lbs)

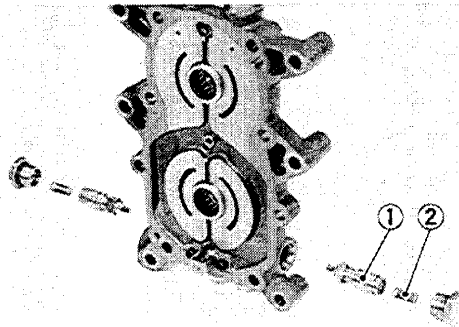

B105P115

Check and High Pressure Relief Valve

1. Check the valve (1) for scratches and damage.
2. Check the valve seat in the port block for damage.
3. Check the spring (2) for breakage and wear.
4. If anything unusual, replace the check and high pressure relief valve complete assembly.

Length of valve spring (long)	Factory spec.	18.2 mm (0.717 in.) (free)
		14.5 mm (0.571 in.) load 3.43 N, 0.35 kgf, 0.77 lbs
Length of valve spring (short)	Factory spec.	12.4 mm (0.488 in.) (free)
		10.5 mm (0.413 in.) load 41.87 N, 4.27 kgf, 9.41 lbs
Tightening torque	Cap nut	53.9 to 63.7 N·m 5.5 to 6.5 kgf·m 39.8 to 47.0 ft·lbs

(1) Valve

(2) Spring

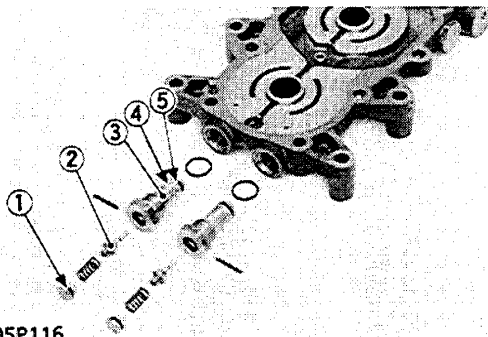

B105P116

Neutral Valve

1. Check the holes of the valve body (3) and the neutral valve (2) for clogging.
2. If clogged, open hole with compressed air.
3. Check the O-rings (1), (5) and the backup ring (4) for scratches and damage.
4. Check the springs for breakage and wear.
5. If the valve surface is scored, replace.
6. If anything unusual, replace.

NOTE

- When reassembling, replace the O-rings and the backup rings.

- (1) O-ring
- (2) Neutral Valve
- (3) Valve Body
- (4) Backup Ring
- (5) O-ring

Length of valve spring (short)	Factory spec.	18.4 mm (0.7244 in.) (free)
		13.9 mm (0.5472 in.) load 43.2 N, 4.4 kgf, 9.7 lbs
Tightening torque	Valve body to case	53.9 to 63.7 N·m 5.5 to 6.5 kgf·m 39.8 to 47.0 ft·lbs

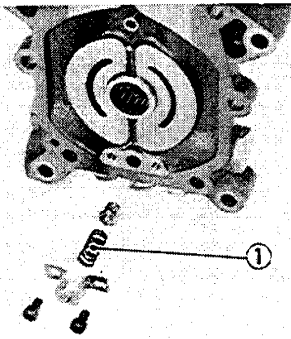

B105P117
(1) Spring

Charge Relief Valve

1. Check the spring (1) for breakage and wear.
2. If it unusual, replace.

Length of valve spring	Factory spec.	23.0 mm (0.906 in.) (free)
		17.0 mm (0.669 in.) load 27 N, 2.7 kgf, 6.0 lbs
		13.0 mm (0.512 in.) load 39 N, 3.95 kgf, 8.71 lbs
Tightening torque	Cap nut	9.8 to 11.3 N·m 1.0 to 1.15 kgf·m 7.2 to 8.3 ft-lbs

[3] TRANSMISSION CASE (B2150HST)

DISASSEMBLING AND ASSEMBLING

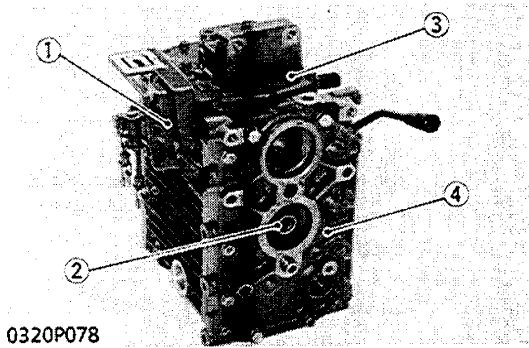

0320P078

Front Cover and Front Case Cover

1. Remove the range selector guide (1).
2. Remove the front case cover (3).
3. Remove the coupling (2).
4. Remove the front cover (4).

(When reassembling)

Tightening torque	Front case cover	34.3 to 39.2 N·m 3.5 to 4.0 kgf·m 25.3 to 28.9 ft-lbs
	Front cover	34.3 to 39.2 N·m 3.5 to 4.0 kgf·m 25.3 to 28.9 ft-lbs

- (1) Range Selector Guide
- (2) Spline Boss Coupling
- (3) Front Case Cover
- (4) Front Cover

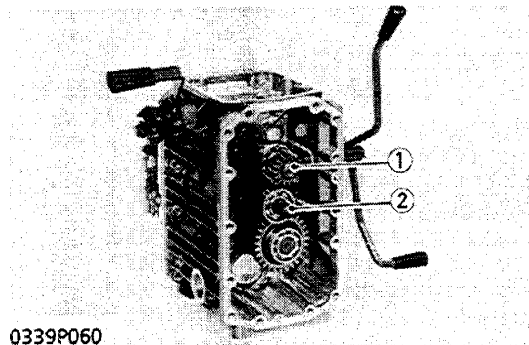

0339P060

1st Shaft and 2nd Shaft

1. Draw out the 2nd shaft (1), 16T gear (3), and bearing (4), (5) as a unit.
2. Draw out the 1st shaft (2), bearing (6), 16T gear (7), bearing (8) and shim (9) as a unit.

(When reassembling)

- Install the 16T gear (3) so that its boss faces the bearing (4).
- Install the 16T gear (7) so that its boss faces the bearing (8).

- (1) 2nd Shaft
- (2) 1st Shaft
- (3) 16T Gear
- (4) Bearing
- (5) Bearing
- (6) Bearing
- (7) 16T Gear
- (8) Bearing
- (9) Shim

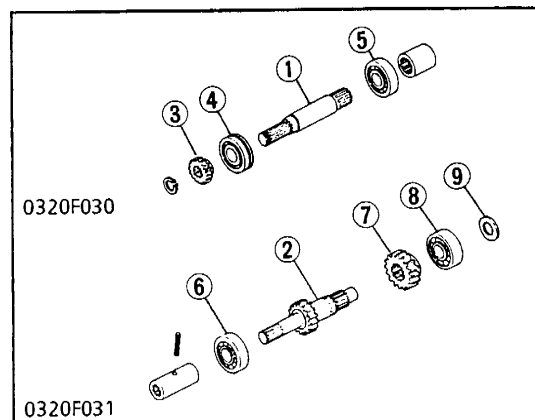

0320F030

0320F031

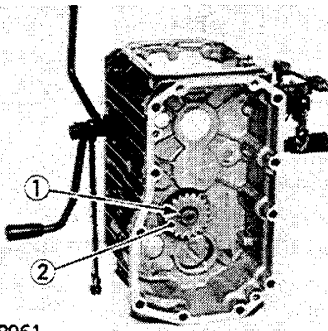

0339P061

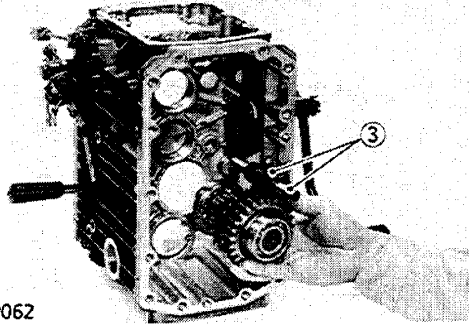

0339P062

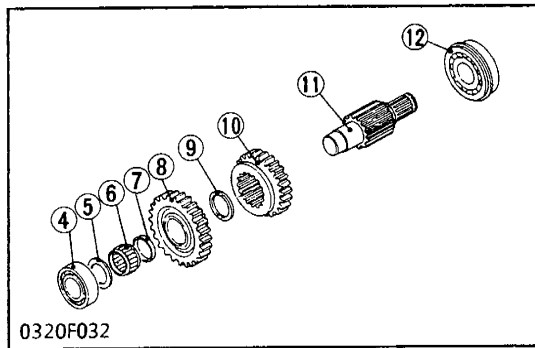

0320F032

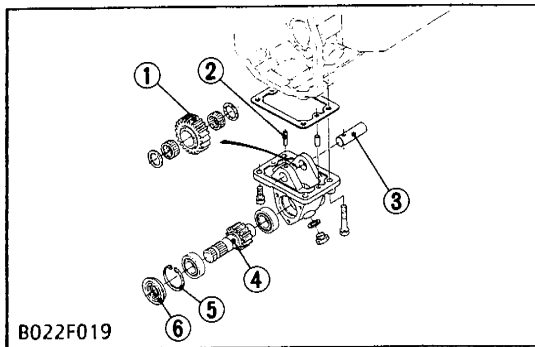

B022F019

6th Shaft

1. Remove the external snap ring(1), and draw out the 20T gear (2).
2. Draw out the 6th shaft (11), bearing (4), collar (5), needle bearing (6), collar (7), 27T gear (8), collar (9), 24T gear (10) and bearing (12) as a unit with the shift fork and fork rod (3).

(When reassembling)

- Install the collars (5), (9) so that their oil grooves face the needle bearing.

- | | |
|-----------------------------|----------------|
| (1) External Snap Ring | (7) Collar |
| (2) 20T Gear | (8) 27T Gear |
| (3) Shift Fork and Fork Rod | (9) Collar |
| (4) Bearing | (10) 24T Gear |
| (5) Collar | (11) 6th Shaft |
| (6) Needle Bearing | (12) Bearing |

Mid-PTO

1. Separate the mid-PTO case from the transmission case
2. After tapping the spring pin (2) into the shaft (3), remove the shaft (3) and the 27T gear (1).
3. Remove the oil seal (6) and the external snap ring (5).
4. Draw out the 16T gear shaft (4) with the bearing on it.

Tightening torque	Plug	32.5 to 36.2 N·m 4.5 to 5.0 kgf·m 44 to 49 ft-lbs
	Mid-PTO case to transmission case	48.0 to 55.9 N·m 4.9 to 5.7 kgf·m 35 to 41 ft-lbs

- | | |
|----------------|------------------------|
| (1) 27T Gear | (4) 16T Gear Shaft |
| (2) Spring Pin | (5) External Snap Ring |
| (3) Shaft | (6) Oil Seal |

[4] DIFFERENTIAL GEAR CASE (B2150HST)

DISASSEMBLING AND ASSEMBLING

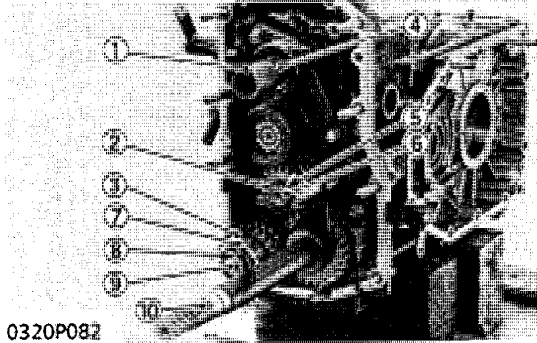

0320P082

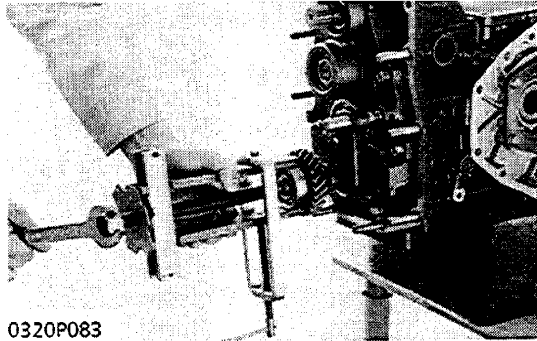

0320P083

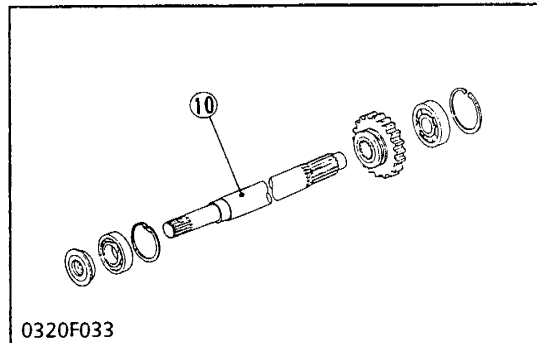

0320F033

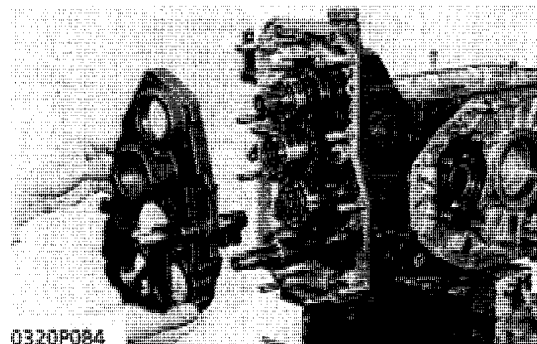

0320P084

Front Drive Shaft (4WD type only)

1. Draw out the coupling (1) from the 3rd shaft (4).
2. Draw out the front drive shaft (10) (4WD type only).
3. Remove the external snap ring (8), and pull out the bearing (7).
4. Draw out the 23T gear (3) from the front 7th shaft (9).
5. Remove the external snap ring (5), and draw out the 16T gear (2) from the spiral bevel pinion shaft (6).

(When reassembling)

- Install 23T gear (3) so that its boss faces the collar.

- | | |
|------------------------|-------------------------------|
| (1) Coupling | (6) Spiral Bevel Pinion Shaft |
| (2) 16T Gear | (7) Bearing |
| (3) 23T Gear | (8) External Snap Ring |
| (4) 3rd Shaft | (9) 7th Shaft Front |
| (5) External Snap Ring | (10) Front Drive Shaft |

Bearing Support

1. Remove the bearing support mounting screws and nuts, and remove the bearing support with the shift fork.

(When reassembling)

Tightening torque	Bearing support mounting screw and nut	16.7 to 19.6 N·m 1.7 to 2.0 kgf·m 12.3 to 14.5 ft-lbs
-------------------	--	---

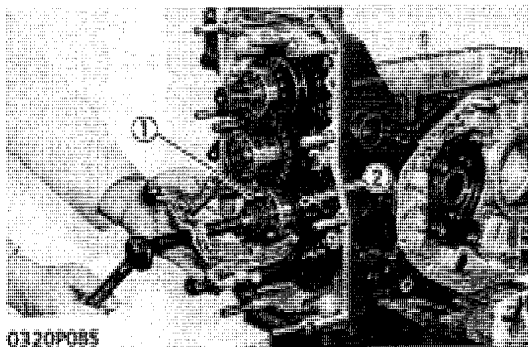

0320P085

3rd Shaft, 4th Shaft and Spiral Bevel Pinion Shaft

1. Pull out the bearing (1) from the spiral bevel pinion shaft (2).
2. Draw out the 3rd shaft (4), 4th shaft (5) and 29-16T gear (6) with shift fork and shaft (3).

(When reassembling)

- Install the thrust collars (7), (8), (9), (10) to the 3rd shaft (4) so that their oil grooves face the needle bearing.
- Install the 4th shaft (5) so that the 27T gear (14) boss faces the bearing (15), the 24T gear (13) boss faces the bearing (15), and the 21T gear (12) boss faces the bearing (11).

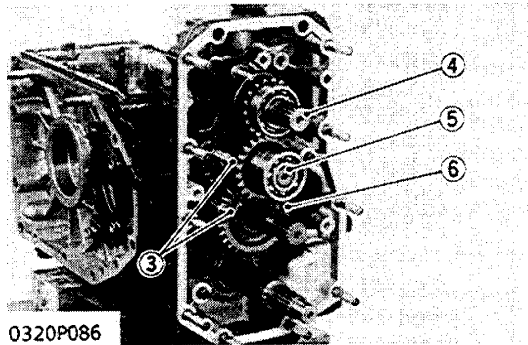

0320P086

- | | |
|-------------------------------|--------------------|
| (1) Ball Bearing | (9) Thrust Collar |
| (2) Spiral Bevel Pinion Shaft | (10) Thrust Collar |
| (3) Shaft | (11) Ball Bearing |
| (4) 3rd Shaft | (12) 21T Gear |
| (5) 4th Shaft | (13) 24T Gear |
| (6) 29-16T Gear | (14) 27T Gear |
| (7) Thrust Collar | (15) Ball Bearing |
| (8) Thrust Collar | |

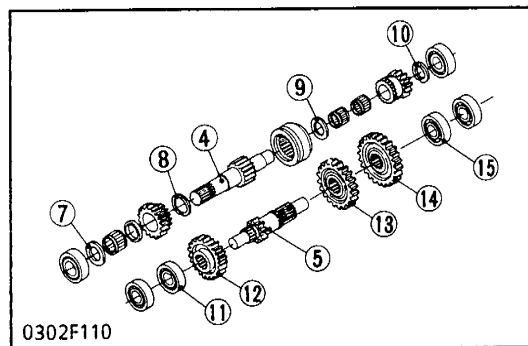

0302F110

PTO Shaft and 7th Shaft Rear

1. Remove the rear cover mounting screw.
2. Remove the PTO shaft with rear cover (1).
3. Draw out the 7th shaft rear (2) from the differential gear case.

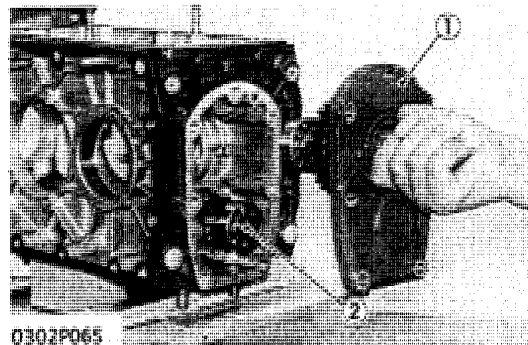

0302P065

(When reassembling)

Tightening torque	Rear cover mounting screw	48.1 to 55.9 N·m 4.9 to 5.7 kgf·m 35.4 to 41.2 ft·lbs
-------------------	---------------------------	---

- (1) Rear Cover (2) 7th Shaft Rear

7th Shaft

1. Draw out the 7th Shaft front (1), 27T gear (2), collar (3), bearing (4), coupling (5) and 7th shaft middle (6) as a unit.

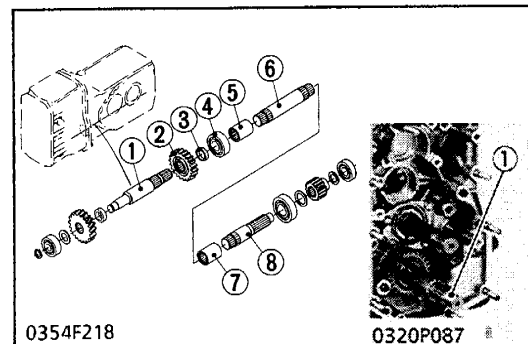

0354F218

0320P087

- | | |
|---------------------|----------------------|
| (1) 7th Shaft Front | (5) Coupling |
| (2) 27T Gear | (6) 7th Shaft Middle |
| (3) Collar | (7) Coupling |
| (4) Bearing | (8) 7th Shaft Rear |

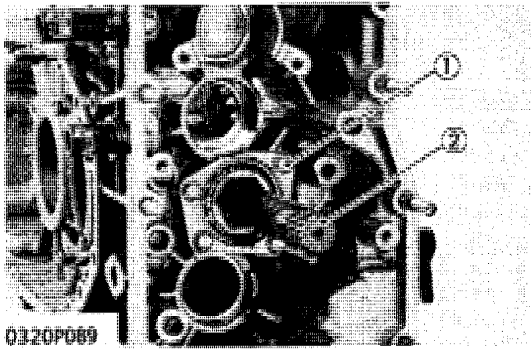

Spiral Bevel Pinion Shaft

1. Remove the bearing holder (1) mounting screws, and pull out the spiral bevel pinion shaft (2).

(When reassembling)

Tightening torque	Bearing holder mounting screw	16.7 to 19.6 N·m 1.7 to 2.0 kgf·m 12.3 to 14.5 ft-lbs

(1) Bearing Holder

(2) Spiral Bevel Pinion Shaft

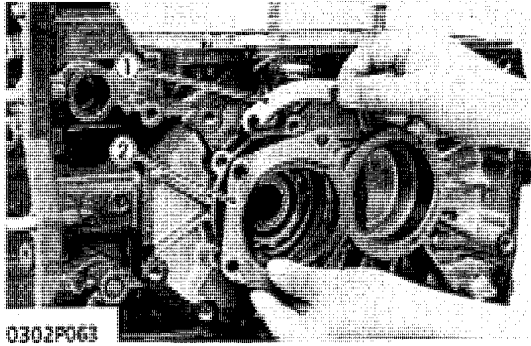

Differential

1. Remove the right and left differential bearing holders (2).
2. Remove the differential assembly from the differential gear case.

(When reassembling)

- Install the differential bearing holders, noting the number of shims (1) in the right and left differential bearing holders.

Tightening torque	Differential bearing holder mounting screw	17.6 to 23.5 N·m 1.8 to 2.4 kgf·m 13.0 to 17.4 ft-lbs

(1) Shim

(2) Differential Bearing Holder

[5] TRANSMISSION CASE (B2150)

DISASSEMBLING AND ASSEMBLING

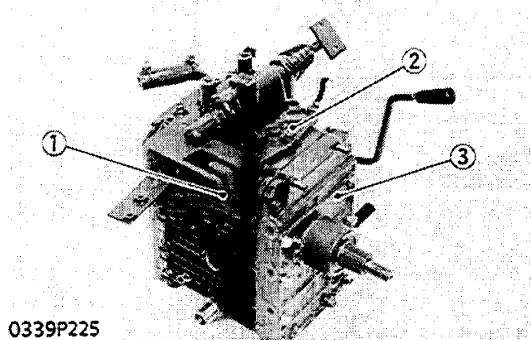

Front Cover and Front Case Cover

1. Remove the range selector guide (1).
2. Remove the front case cover (2).
3. Remove the front cover (3) with the 15T gear shaft.

(When reassembling)

Tightening torque	Front case cover	29.4 to 44.1 N·m 3.0 to 4.5 kgf·m 21.7 to 32.5 ft-lbs
	Front cover	

(1) Range Selector Guide

(3) Front Cover

(2) Front Case Cover

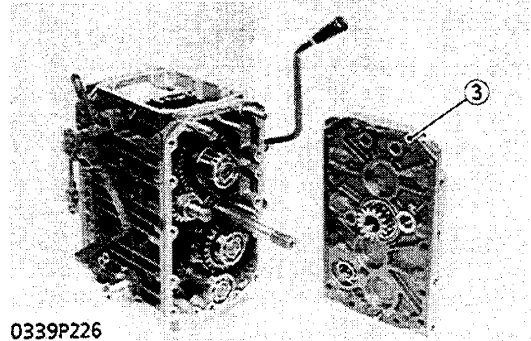

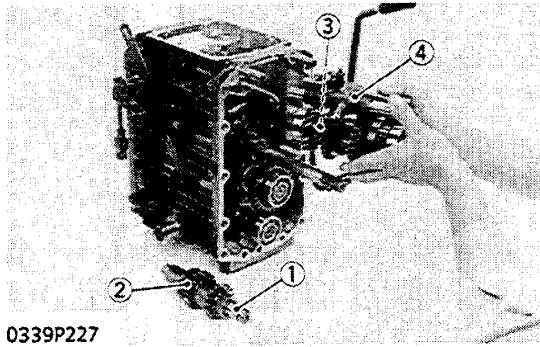

0339P227

Reverse Shaft and 2nd Shaft

1. Draw out the reverse shaft (1) with the 16-16T gear (2).
2. Draw out the 2nd shaft (3) with the shift fork (4).

(1) Reverse Shaft
(2) 16T-16T Gear

(3) 2nd Shaft
(4) Shift Fork

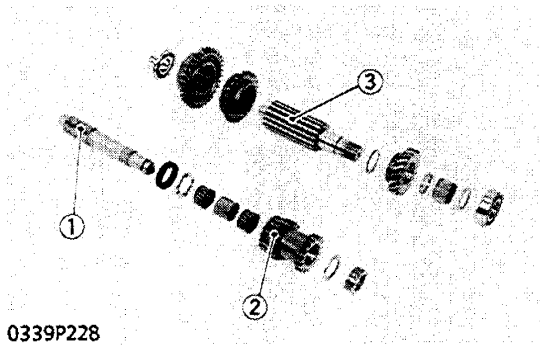

0339P228

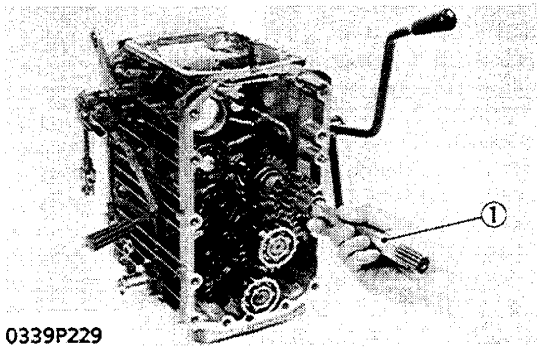

0339P229

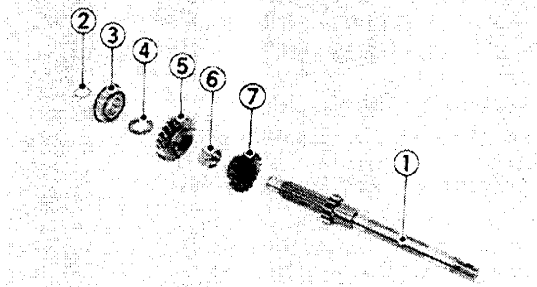

0339P230

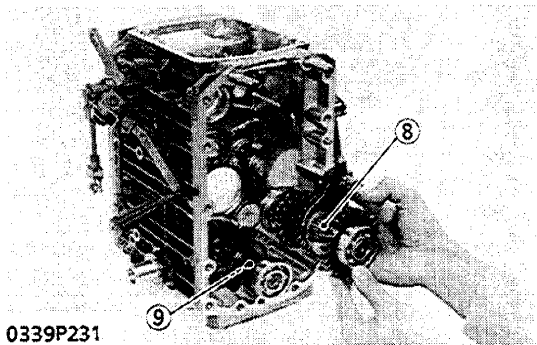

0339P231

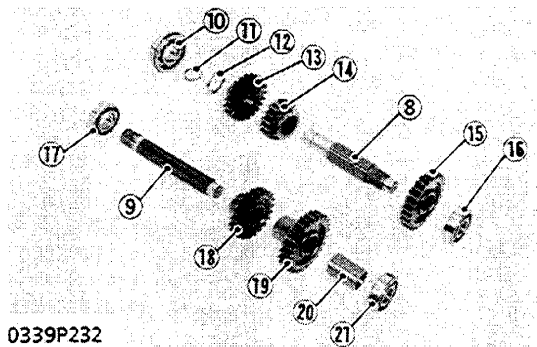

0339P232

1st , 6th and 7th Shaft

1. Remove the external snap ring (2) and tap out the 1st shaft (1) to the front side by hitting.
2. Draw out the 6th shaft (8) with the shift fork of PTO change.
3. Tap out the 7th shaft (9) to the back side.

- | | |
|-------------------------|---------------|
| (1) 1st Shaft | (12) Collar |
| (2) External Snap Ring | (13) 20T Gear |
| (3) Bearing | (14) 17T Gear |
| (4) Collar | (15) 25T Gear |
| (5) 20T Gear | (16) Bearing |
| (6) Collar | (17) Bearing |
| (7) 16T Gear | (18) 21T Gear |
| (8) 6th Shaft | (19) 25T Gear |
| (9) 7th Shaft | (20) Collar |
| (10) Bearing | (21) Bearing |
| (11) External Snap Ring | |

Mid-PTO

Refer to page S.3-59.

[6] DIFFERENTIAL GEAR CASE (B2150)

DISASSEMBLING AND ASSEMBLING

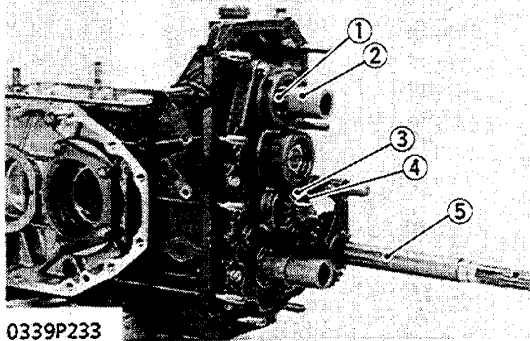

0339P233

Front Drive Shaft (4WD type only)

1. Draw out the coupling (2) from the 3rd shaft (1).
2. Draw out the front drive shaft (5) (4WD type only).
3. Remove the collars.
4. Remove the external snap ring (4), and draw out the 16T gear (3) from the spiral bevel pinion shaft .

- | | |
|---------------|------------------------|
| (1) 3rd Shaft | (4) External Snap Ring |
| (2) Coupling | (5) Front Drive Shaft |
| (3) 16T Gear | |

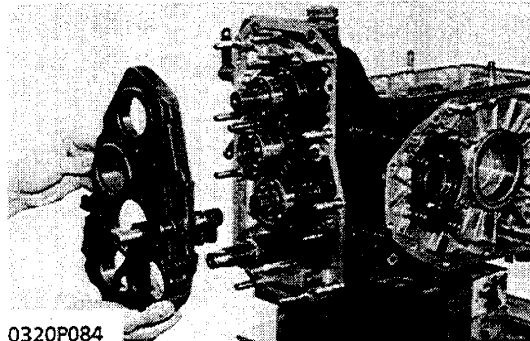

0320P084

Bearing Support

1. Remove the bearing support mounting screws and nuts, and remove the bearing support with shift fork.

(When reassembling)

Tightening torque	Bearing support mounting screw and nut	16.7 to 19.6 N·m 1.7 to 2.0 kgf·m 12.3 to 14.5 ft-lbs
-------------------	--	---

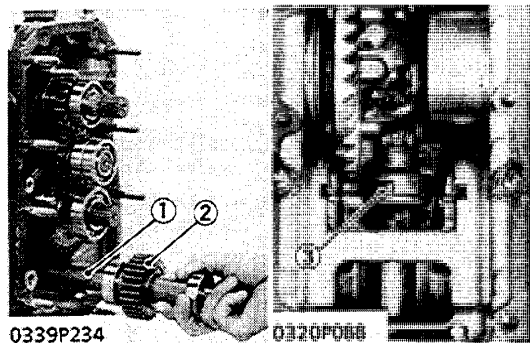

0339P234

0320P088

7th Shaft and One-way Clutch Cam

1. Draw out the 7th Shaft middle (1), 27T gear (2) as a unit.
2. Take out the collar (8) and clutch cam (3) in the differential case.

- | | |
|----------------------|------------------------|
| (1) 7th Shaft Middle | (5) Collar |
| (2) 27T Gear | (6) Bearing |
| (3) Clutch Cam | (7) External Snap Ring |
| (4) Bearing | (8) Collar |

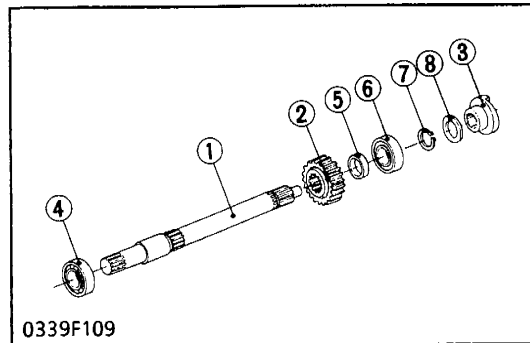

0339F109

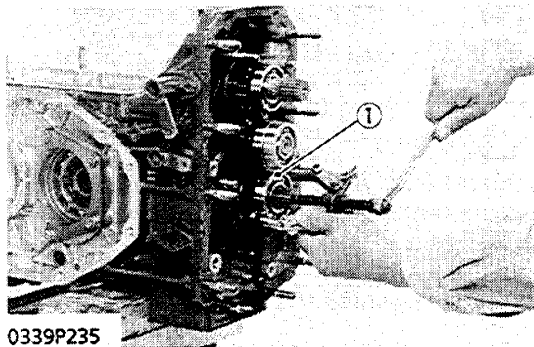

0339P235

3rd Shaft and 4th Shaft

1. Remove the bearing (1) from the spiral bevel pinion shaft with the gear puller.
2. Pull out the 3rd shaft (2), 4th shaft (3) and 29T-15T gear (4) with the shift fork (5) and fork shaft (6).

- | | |
|--------------------|---------------------|
| (1) Bearing | (8) 18T Gear |
| (2) 3rd Shaft | (9) Shifter |
| (3) 4th Shaft | (10) Needle Bearing |
| (4) 29T-15T Gear | (11) 13T Gear |
| (5) Shift Fork | (12) 22T Gear |
| (6) Fork Shaft | (13) 25T Gear |
| (7) Needle Bearing | (14) 27T Gear |

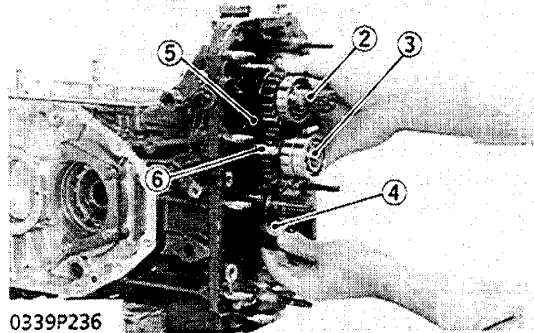

0339P236

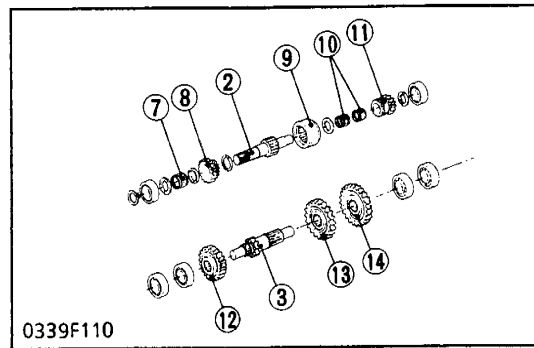

0339F110

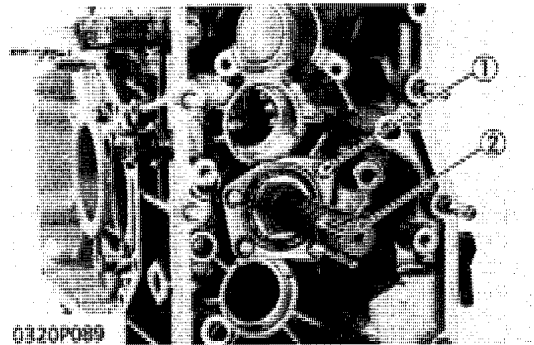

0320P089

Spiral Bevel Pinion Shaft

1. Remove the bearing holder mounting screws (1), and pull out the spiral bevel pinion shaft (2).

(When reassembling)

Tightening torque	Bearing holder mounting screw	16.7 to 19.6 N·m 1.7 to 2.0 kgf·m 12.3 to 14.5 ft-lbs
-------------------	-------------------------------	---

(1) Screw

(2) Spiral Bevel Pinion Shaft

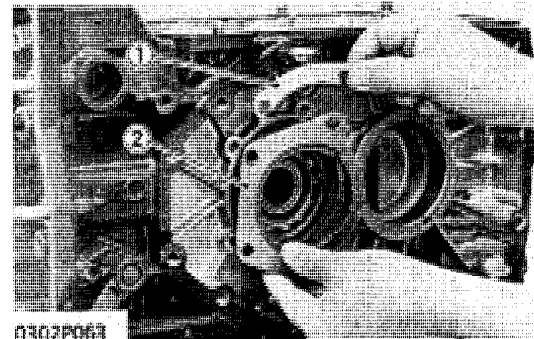

0302P063

Differential

1. Remove the right and left differential bearing holders (2).
2. Remove the differential assembly from the differential gear case.

(When reassembling)

- Install the differential bearing holders, noting the number of shims (1) in the right and left differential bearing holders.

Tightening torque	Differential bearing holder mounting screw	17.6 to 23.5 N·m 1.8 to 2.4 kgf·m 13.0 to 17.4 ft-lbs
-------------------	--	---

(1) Shim

(2) Differential Bearing Holder

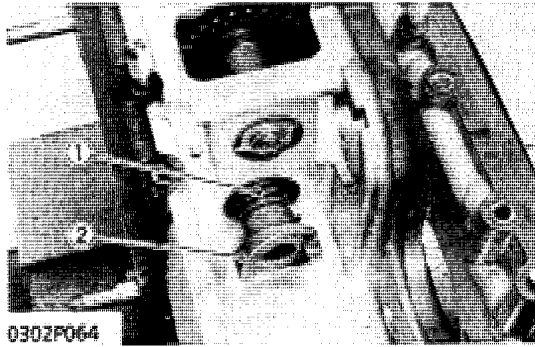

One-way Clutch Cam

1. Remove the clutch cam (2) and spring (1).

(When reassembling)

- When installing the clutch cam, be sure to install the collars (3), (4).

- (1) Spring
- (2) Cam
- (3) Collar
- (4) Collar

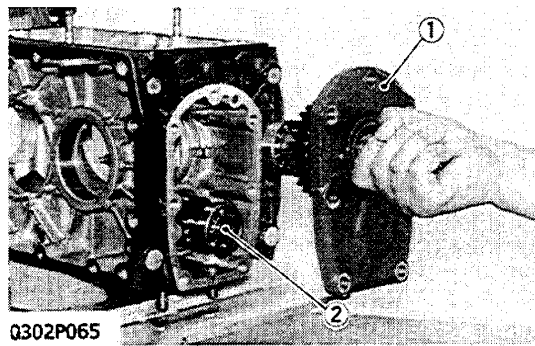
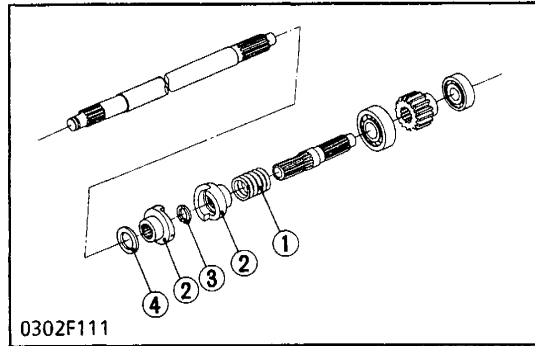

PTO Shaft and 7th Shaft Rear

1. Remove the rear cover mounting screw.
2. Remove the PTO shaft with rear cover (1).
3. Draw out the 7th shaft rear (2) from the differential gear case.

(When reassembling)

Tightening torque	Rear cover mounting screw	48.1 to 55.9 N·m 4.9 to 5.7 Kgf·m 35.4 to 41.2 ft-lbs
-------------------	---------------------------	---

- (1) Rear Cover
- (2) 7th Shaft Rear

[7] TRANSMISSION CASE AND DIFFERENTIAL GEAR CASE SERVICING

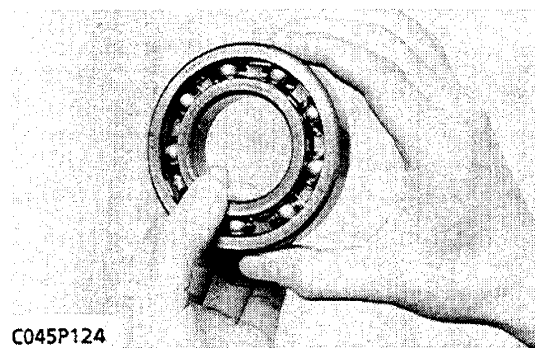

Bearing Check

1. While holding the inner race, push and pull the outer race in all directions to check for wear and roughness.
2. Apply transmission oil to the bearing and hold the inner race. Turn the outer race to check for smooth rotation of the race.
3. For needle bearing, lay the needle rollers to check for any damage and wear.
4. Replace it if defects are found.

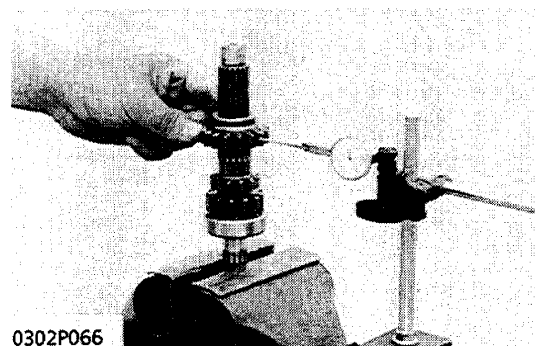

Backlash between Gear and Spline

1. Secure the shaft in a vise.
2. Set a dial indicator (lever type).
3. Move the gear by hand for measurement.
4. If the measurement exceeds the allowable limit, replace it.

Backlash between gear and spline	Factory spec.	0.030 to 0.078 mm 0.001 to 0.003 in.
	Allowable limit	0.2 mm 0.008 in.

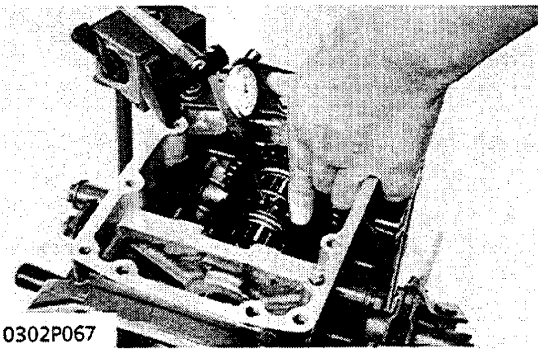

0302P067

Gear Backlash

1. Set a dial indicator (lever type).
2. Move the gear to measure the backlash, while holding the mating gear.
3. If the measurement exceeds the allowable limit, replace it.

Gear backlash	Factory spec.	0.10 to 0.20 mm 0.004 to 0.008 in.
	Allowable limit	0.4 mm 0.016 in.

■ **NOTE**

● **Dial indicator setting**

1. Remove the front cover (1), and remove the shift fork and fork shaft.
2. Replace the front cover, and set the PTO guide plate (2) on the top of the transmission case.
3. Set the dial indicator (magnet base type) on the PTO guide plate.

(1) Front Cover

(2) PTO Guide Plate

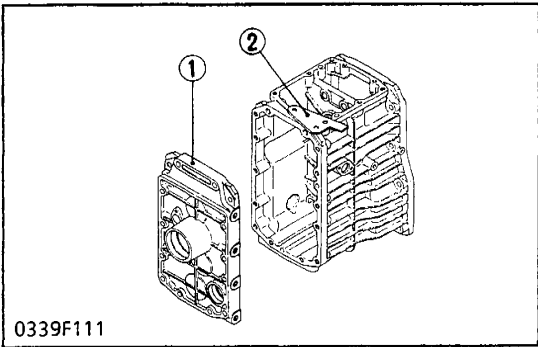

0339F111

Clearance between Shift Fork and Shift Gear Groove

1. Insert the fork into the shift gear groove and measure the clearance with a feeler gauge.
2. If the clearance exceeds the allowable limit, replace it.

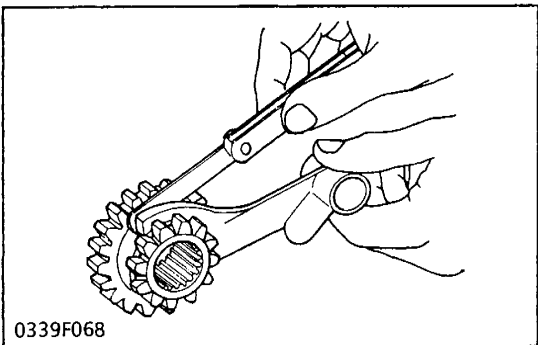

0339F068

■ **B2150**

Clearance between 32T gear and shift fork	Factory spec.	0.10 to 0.35 mm 0.004 to 0.014 in.
	Allowable limit	0.5 mm 0.020 in.
Clearance between 24T gear and shift fork	Factory spec.	0.10 to 0.30 mm 0.004 to 0.012 in.
	Allowable limit	0.5 mm 0.020 in.
Clearance between shifter and shift fork	Factory spec.	0.10 to 0.35 mm 0.004 to 0.014 in.
	Allowable limit	0.5 mm 0.020 in.
Clearance between 29T gear and shift fork	Factory spec.	0.10 to 0.35 mm 0.004 to 0.014 in.
	Allowable limit	0.5 mm 0.020 in.
Clearance between 17T gear and PTO shift fork	Factory spec.	0.10 to 0.35 mm 0.004 to 0.014 in.
	Allowable limit	0.5 mm 0.020 in.
Clearance between 27T gear and front drive shift fork	Factory spec.	0.10 to 0.35 mm 0.004 to 0.014 in.
	Allowable limit	0.5 mm 0.020 in.

■ **B2150HST**

Clearance between 24T gear and PTO shift fork	Factory spec.	0.10 to 0.30 mm 0.004 to 0.012 in.
	Allowable limit	0.5 mm 0.020 in.
Clearance between 16T-29T gear and shift fork	Factory spec.	0.10 to 0.35 mm 0.004 to 0.014 in.
	Allowable limit	0.5 mm 0.020 in.
Clearance between 24T gear and PTO shift fork	Factory spec.	0.10 to 0.35 mm 0.004 to 0.014 in.
	Allowable limit	0.5 mm 0.020 in.

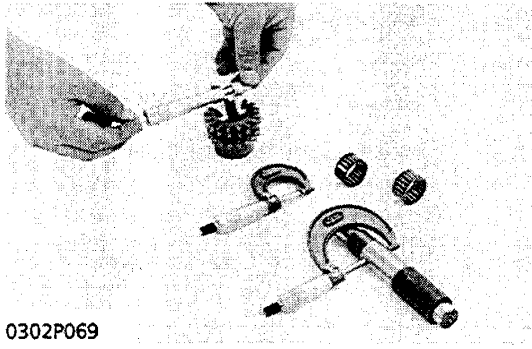

0302P069

Clearance between Gear and Shaft

1. Measure the gear I.D. with an inside micrometer, and then shaft O.D. with an outside micrometer.
2. Measure the O.D. of two needles in the needle bearing with an outside micrometer.
3. Clearance is the difference between the gear I.D. and the sum of shaft O.D. and two needle O.D.
4. If the clearance is not within the factory specifications, replace it.

■ **B2150**

Clearance between 15T shaft gear and 1st shaft	Factory spec.	0.014 to 0.052 mm 0.0006 to 0.0020 in.
	Allowable limit	0.10 mm 0.0039 in.
1st shaft O.D.	Factory spec.	19.980 to 19.993 mm 0.7866 to 0.7871 in.
15T shaft gear I.D.	Factory spec.	26.007 to 26.020 mm 1.0239 to 1.0244 in.
Needle O.D.	Factory spec.	2.994 to 3.000 mm 0.1179 to 0.1181 in.

Clearance between 20T gear and 2nd shaft	Factory spec.	0.009 to 0.059 mm 0.0004 to 0.0023 in.
	Allowable limit	0.10 mm 0.0039 in.
2nd shaft O.D.	Factory spec.	27.987 to 28.000 mm 1.1019 to 1.1024 in.
20T gear I.D.	Factory spec.	32.009 to 32.034 mm 1.2602 to 1.2612 in.
Needle O.D.	Factory spec.	1.994 to 2.000 mm 0.0785 to 0.0787 in.

■ **B2150HST**

Clearance between 12T gear and 3rd shaft	Factory spec.	0.007 to 0.053 mm 0.0003 to 0.0021 in.
	Allowable limit	0.10 mm 0.0039 in.
3rd shaft O.D.	Factory spec.	21.987 to 22.000 mm 0.8656 to 0.8661 in.
12T gear I.D.	Factory spec.	27.007 to 27.028 mm 1.0633 to 1.0641 in.
Needle O.D.	Factory spec.	2.494 to 2.500 mm 0.0982 to 0.0984 in.

Clearance between 27T gear and 6th shaft	Factory spec.	0.009 to 0.059 mm 0.0004 to 0.0023 in.
	Allowable limit	0.10 mm 0.0039 in.
6th shaft O.D.	Factory spec.	27.987 to 28.000 mm 1.1019 to 1.1024 in.
27T gear I.D.	Factory spec.	32.009 to 32.034 mm 1.2602 to 1.2612 in.
Needle O.D.	Factory spec.	1.994 to 2.000 mm 0.0785 to 0.0787 in.

■ **B2150-B2150HST**

Clearance between 18T gear and 3rd shaft	Factory spec.	0.009 to 0.059 mm 0.0004 to 0.0023 in.
	Allowable limit	0.10 mm 0.0039 in.
2nd shaft O.D.	Factory spec.	27.987 to 28.000 mm 1.1019 to 1.1024 in.
20T gear I.D.	Factory spec.	32.009 to 32.034 mm 1.2602 to 1.2612 in.
Needle O.D.	Factory spec.	1.994 to 2.000 mm 0.0785 to 0.0787 in.

Clearance between 27T gear and idle shaft	Factory spec.	0.007 to 0.053 mm 0.0003 to 0.0021 in.
	Allowable limit	0.10 mm 0.0039 in.
Idle shaft O.D.	Factory spec.	21.987 to 22.000 mm 0.8656 to 0.8661 in.
27T gear I.D.	Factory spec.	30.007 to 30.028 mm 1.1814 to 1.1822 in.
Needle O.D.	Factory spec.	3.994 to 4.000 mm 0.1572 to 0.1575 in.

■ **B2150**

Clearance between 13T gear and 3rd shaft	Factory spec.	0.007 to 0.053 mm 0.0003 to 0.0021 in.
	Allowable limit	0.10 mm 0.0039 in.
3rd shaft O.D. (Rear side)	Factory spec.	21.987 to 22.000 mm 0.8656 to 0.8661 in.
13T gear I.D.	Factory spec.	27.007 to 27.028 mm 1.0633 to 1.0641 in.
Needle O.D.	Factory spec.	2.494 to 2.500 mm 0.0982 to 0.0984 in.

Clearance between 16T-16T gear and reverse shaft	Factory spec.	0.007 to 0.045 mm 0.0003 to 0.0018 in.
	Allowable limit	0.10 mm 0.0039 in.
Reverse shaft O.D.	Factory spec.	24.987 to 25.000 mm 0.9837 to 0.9843 in.
16T-16T gear I.D.	Factory spec.	30.007 to 30.020 mm 1.1814 to 1.1819 in.
Needle O.D.	Factory spec.	2.494 to 2.500 mm 0.0982 to 0.0984 in.

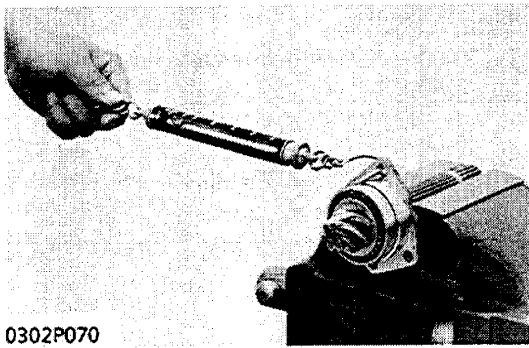

0302P070

Turning Torque of Spiral Bevel Pinion Shaft

1. Secure the spiral bevel pinion shaft (5) in a vise.
2. Set a spring balance to the screw hole in the bearing holder (3).
3. Pull the spring balance in the direction at a right angle to the center line of the spiral bevel pinion shaft to measure the turning load.
4. If the turning load is not within the factory specifications, adjust with the staking nut (1) on the spiral bevel pinion shaft.

Turning torque of spiral bevel pinion shaft	Factory spec.	0.98 to 4.90 N·m 0.10 to 0.50 kgf·m 0.22 to 1.10 ft-lbs
---	---------------	---

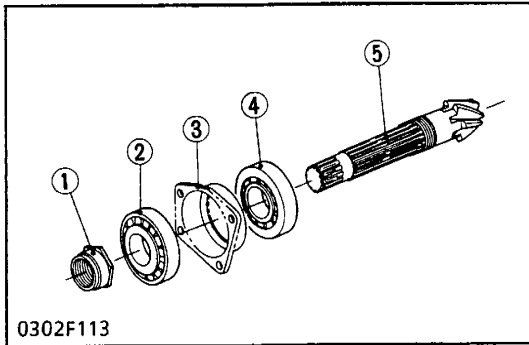

0302F113

- (1) Staking Nut
- (2) Taper Roller Bearing
- (3) Bearing Holder
- (4) Taper Roller Bearing
- (5) Spiral Bevel Pinion

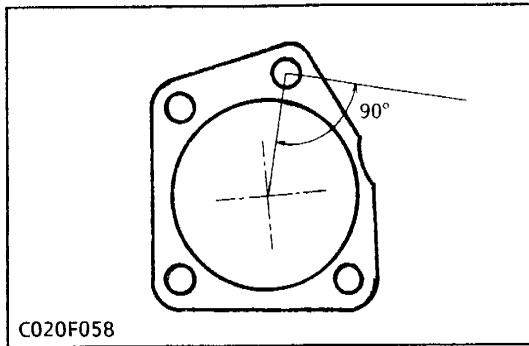

C020F058

NOTE

- For measurement, pull the spring balance at a right angle as shown in the figure.

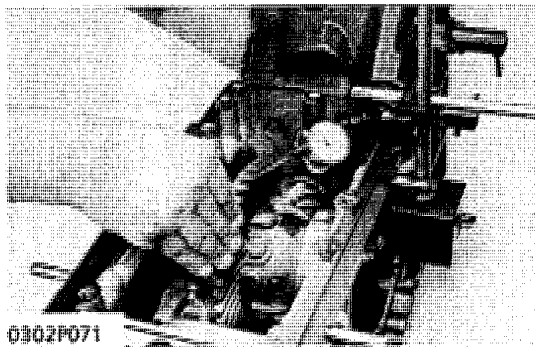

C002F071

Backlash between Spiral Bevel Pinion and Spiral Bevel Gear

1. Set the dial indicator (lever type) with its finger on the tooth surface of bevel gear.
2. Measure the backlash by fixing the spiral bevel pinion (4) and moving bevel gear (2) by hand.
3. If the clearance exceeds the allowable limit, adjust with the shims (1), (5) at bearing holders.
4. Adjust the backlash properly by repeating the above procedures.

Backlash between spiral bevel pinion and spiral bevel gear	Factory spec.	0.10 to 0.20 mm 0.0039 to 0.0080 in.
--	---------------	---

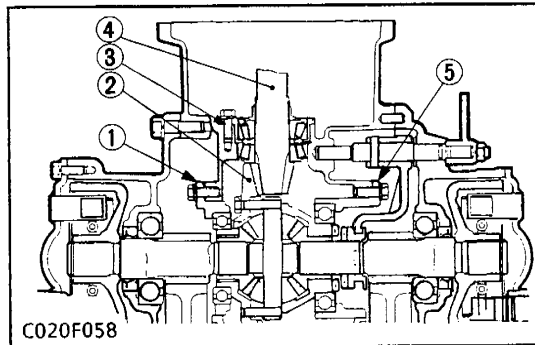

• **Proper Contact**



More than 35% red lead contact area on the gear tooth surface. The center of tooth contact at 1/3 of the entire width from the small end.

C065F198

• **Heal Contact**

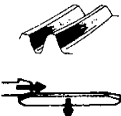

• **Tip Contact**



C065F199

Replace adjusting shim (3) with thinner one to move the bevel pinion shaft backward. And place the right side shim (5) to the left to move the bevel gear leftward. Repeat above until the proper tooth contact and backlash are achieved.

• **Toe Contact**

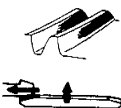

• **Base Contact**



C065F200

Replace adjusting shim (3) with thicker one to move the bevel pinion shaft forward. And place the right side shim (1) to the right to move the bevel gear rightward. Repeat above until the proper tooth contact and backlash are achieved.

5. Apply red lead lightly over several teeth at three positions equally spaced on the bevel gear (2).
6. Turn the spiral bevel pinion (4) while pressing a wooden piece against the periphery of the bevel gear (2).
7. Check the tooth contact if not proper, adjust according to the instructions below.

(Reference)

- Thickness of shims (1), (5)
0.1 mm (0.004 in.), 0.2 mm (0.008 in.)
0.5 mm (0.020 in.)
- Thickness of shims (3)
0.2 mm (0.008 in.), 0.5 mm (0.020 in.)
0.8 mm (0.031 in.)

- (1) Shim
- (2) Bevel Gear
- (3) Shim
- (4) Spiral Bevel Pinion
- (5) Shim

CONTENTS

TROUBLESHOOTING	S.4-1
SERVICING SPECIFICATIONS	S.4-1
TIGHTENING TORQUES	S.4-2
CHECKING, DISASSEMBLING AND SERVICING	S.4-3
[1] DIFFERENTIAL GEAR	
CHECKING AND ADJUSTING	S.4-3
DISASSEMBLING AND ASSEMBLING	S.4-3
SERVICING	S.4-4
[2] AXLE CASE	
DISASSEMBLING AND ASSEMBLING	S.4-6

TROUBLESHOOTING

Symptom	Probable Cause	Solution	Reference Page
Excessive or Unusual Noise At All Time	● Improper backlash between 6T spiral bevel pinion and bevel gear	Adjust	S.3-40,71
	● Improper backlash between differential pinion and differential side gear	Adjust	S.4-5
	● Bearing worn	Replace	—
	● Insufficient or improper type of transmission fluid used	Replenish or Replace	S.G-3 S.S-4,16
Noise while Turning	● Differential pinions or differential side gears worn or damaged	Replace	S.4-4,5
	● Differential lock binding (does not disengage)	Replace	S.4-3,6
	● Bearings worn	Replace	S.4-3
Differential Lock Can Not Be Set	● Differential lock shift fork damaged	Replace	S.4-6
	● Differential lock shifter mounting pin damaged	Replace	S.4-6
	● Differential lock clutch damaged	Replace	S.4-6
Differential Lock Pedal Does Not Return	● Differential lock pedal return spring weaken or damaged	Replace	S.S-10,13, 21,27
	● Differential lock fork shaft rusted	Repair	—

SERVICING SPECIFICATIONS

Item		Factory Specification	Allowable Limit	
Differential Pinion to Differential Side Gear Adjust Shim	Backlash	0.1 to 0.3 mm 0.004 to 0.012 in.	0.4 mm 0.016 in.	
	Thickness	0.8 mm (0.0315 in.)	—	
		1.0 mm (0.0394 in.)	—	
		1.2 mm (0.0472 in.)	—	
Differential Case to Differential Side Gear (B1550-B1750-B1550HST-B1750HST)	Clearance	0.025 to 0.066 mm 0.0016 to 0.0029 in.	0.30 mm 0.0118 in.	
	Differential Case	I.D.	32.000 to 32.025 mm 1.2598 to 1.2608 in.	—
	Bushing	I.D.	32.000 to 32.025 mm 1.2598 to 1.2608 in.	—
	Differential Side Gear	O.D.	31.959 to 31.975 mm 1.2582 to 1.2589 in.	—
Differential Pinion Shaft to Differential Pinion (B1550.B1750.B1550HST.B1750HST)	Clearance	0.016 to 0.045 mm 0.0006 to 0.0018 in.	0.30 mm 0.0118 in.	
	Differential Pinion Shaft	O.D.	15.973 to 15.984 mm 0.6289 to 0.6293 in.	—
	Differential Pinion	I.D.	16.000 to 16.018 mm 0.6299 to 0.6306 in.	—

SERVICING SPECIFICATIONS

Item		Factory Specification	Allowable Limit
Differential Case to Differential Side Gear (B2150-B2150HST)	Clearance	0.020 to 0.085 mm 0.0008 to 0.0030 in.	0.30 mm 0.0118 in.
	Differential Case	I.D. 37.000 to 37.025 mm 1.4567 to 1.4576 in.	—
	Bushing	I.D. 37.000 to 37.025 mm 1.4567 to 1.4576 in.	—
	Differential Side Gear	O.D. 36.940 to 36.980 mm 1.4543 to 1.4559 in.	—
Differential Pinion Shaft to Differential Pinion (B2150-B2150HST)	Clearance	0.016 to 0.054 mm 0.0006 to 0.0021 in.	0.30 mm 0.0118 in.
	Differential Pinion Shaft	O.D. 15.973 to 15.984 mm 0.6289 to 0.6293 in.	—
	Differential Pinion	I.D. 16.000 to 16.027 mm 0.6299 to 0.6310 in.	—

TIGHTENING TORQUES

Tightening torques of screws and nuts on the table below are especially specified.
(For general use screws and nuts: See page S.G-4)

Item	N·m	kgf·m	ft-lbs
Spiral Bevel Gear Screw	29.4 to 34.3	3.0 to 3.5	21.7 to 25.3
Check Chain Bracket Screw	62.8 to 72.5	6.4 to 7.4	46.3 to 53.5

CHECKING, DISASSEMBLING AND SERVICING

[1] DIFFERENTIAL GEAR

CHECKING AND ADJUSTING



0342P060

Adjusting Differential Lock Pedal

1. Loosen the lock nut (1).
2. Remove the cotter pin (2) and disconnect the rod from the pedal.
3. Lifting up the differential lock pedal, adjust the length of differential lock rod until the top of the rod is put into the hole of pedal smoothly.

NOTE

- After adjustment, secure the differential lock rod with the lock nut (1).

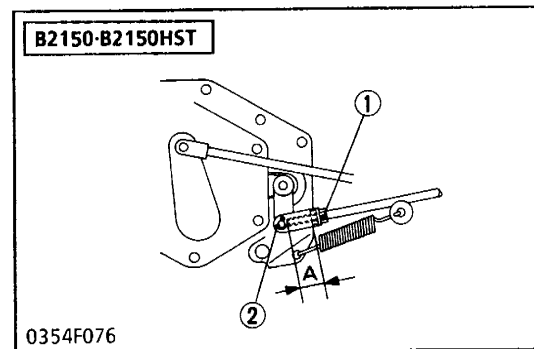

0354F076

Length "A"	Allowable limit	B1550-B1750 B1550HST-B1750HST	13 to 17 mm 0.51 to 0.66 in.
		B2150-B2150HST	13 to 17 mm 0.51 to 0.66 in.

(1) Lock Nut

(2) Cotter Pin

DISASSEMBLING AND ASSEMBLING

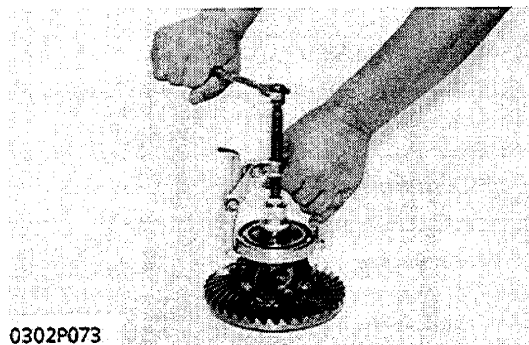

0302P073

Bearing

1. Remove the right and left bearings from the differential case.

(When reassembling)

- Apply liquid lock to the spiral bevel gear mounting screws.
- Replace the lock plate with a new one.
- Install the lock plate over the dowel pins.

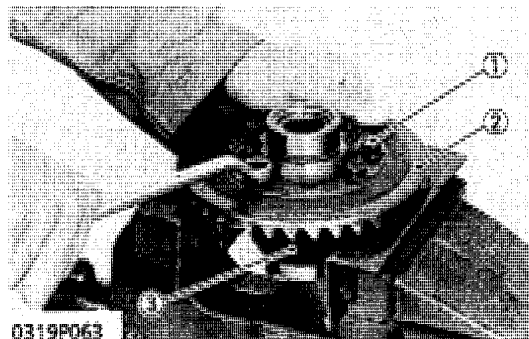

0319P063

Spiral Bevel Gear

1. Remove the bevel gear mounting screws (1).
2. Remove the spiral bevel gear (2) from the differential case (3).

Tightening torque	Spiral bevel gear mounting screw	29.4 to 34.3 N·m 3.0 to 3.5 kgf·m 21.7 to 25.3 ft-lbs
-------------------	----------------------------------	---

(1) Screw

(2) Spiral Bevel Gear

(3) Differential Case

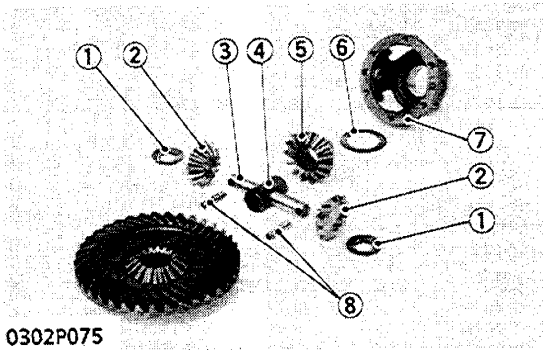

0302P075

- (1) Collar
- (2) Differential Pinion
- (3) Differential Pinion Shaft * 1
- (4) Differential Thrust Collar
- (5) Differential Side Gear
- (6) Shim
- (7) Differential Case
- (8) Dowel Pin * 1

Differential Side Gear and Differential Pinion

1. Put parting marks on the differential pinion(2) and the differential side gear (5).
2. Tap out the dowel pins (8).
3. Remove the differential pinion shaft (3).
4. Remove the differential pinion, differential pinion collar (1), differential side gear, shim(6) and differential thrust collar (4).

(When reassembling)

- Install the differential pinion and differential side gear, aligning the parting marks.

■ **NOTE (※ 1)**

Serial No. affected: **B2150E :** above 10228
B2150D : above 51656
B2150HSE : above 10262
B2150HSD : above 53401

- The differential pinion shaft has only one hole for setting the long dowel pin to prevent the differential pinion shaft (3) from being removed. The short dowel pin is set to the differential case.

SERVICING

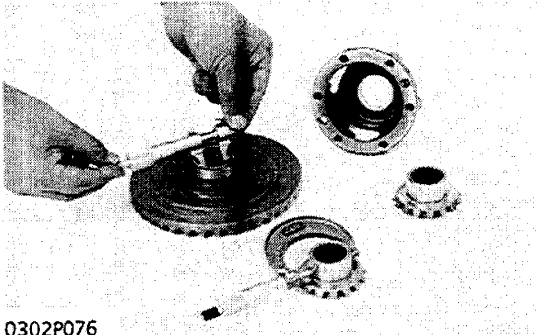

0302P076

Clearance between Differential Case and Differential Side Gear

1. Measure the differential side gear boss O.D with an outside micrometer.
2. Measure the differential case I.D and the spiral bevel gear I.D with an inside micrometer.
3. If the clearance exceeds the allowable limit, replace it.

■ **B1550-B1750-B1550HST-B1750HST**

Clearance between differential case and differential side gear	Factory spec.	0.025 to 0.066 mm 0.0016 to 0.0029 in.
	Allowable limit	0.30 mm 0.0118 in.
Differential case I.D	Factory spec.	32.000 to 32.025 mm 1.2598 to 1.2608 in.
Differential side gear O.D	Factory spec.	31.959 to 31.975 mm 1.2582 to 1.2589 in.
Spiral bevel gear bushing I.D	Factory spec.	32.000 to 32.025 mm 1.2598 to 1.2608 in.

■ **B2150-B2150HST**

Clearance between differential case and differential side gear	Factory spec.	0.020 to 0.085 mm 0.0008 to 0.0030 in.
	Allowable limit	0.30 mm 0.0118 in.
Differential case I.D	Factory spec.	37.000 to 37.025 mm 1.4567 to 1.4576 in.
Differential side gear O.D	Factory spec.	36.940 to 36.980 mm 1.4543 to 1.4559 in.
Spiral bevel gear I.D *	Factory spec.	37.000 to 37.025 mm 1.4567 to 1.4576 in.

* This is a bushless bevel gear.

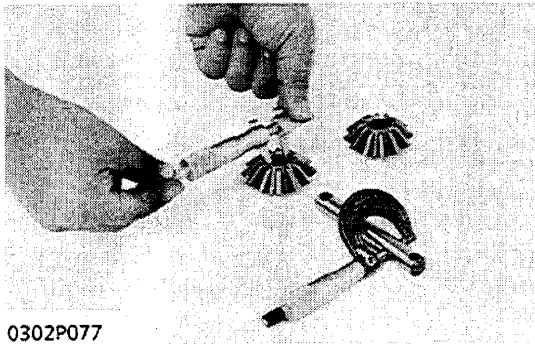

0302P077

Clearance between Differential Pinion Shaft and Differential Pinion

1. Measure the differential pinion shaft O.D. with an outside micrometer.
2. Measure the differential pinion I.D. with an inside micrometer.
3. If the clearance exceeds the allowable limit, replace it.

■ **B1550-B1750-B1550HST-B1750HST**

Clearance between differential pinion shaft and differential pinion	Factory spec.	0.016 to 0.045 mm 0.0006 to 0.0018 in.
	Allowable limit	0.30 mm 0.0118 in.
Differential pinion shaft O.D.	Factory spec.	15.973 to 15.984 mm 0.6289 to 0.6293 in.
Differential pinion I.D.	Factory spec.	16.000 to 16.018 mm 0.6299 to 0.6306 in.

■ **B2150-B2150HST**

Clearance between differential pinion shaft and differential pinion	Factory spec.	0.016 to 0.054 mm 0.0006 to 0.0021 in.
	Allowable limit	0.30 mm 0.0118 in.
Differential pinion shaft O.D.	Factory spec.	15.973 to 15.984 mm 0.6289 to 0.6293 in.
Differential pinion I.D.	Factory spec.	16.000 to 16.027 mm 0.6299 to 0.6310 in.

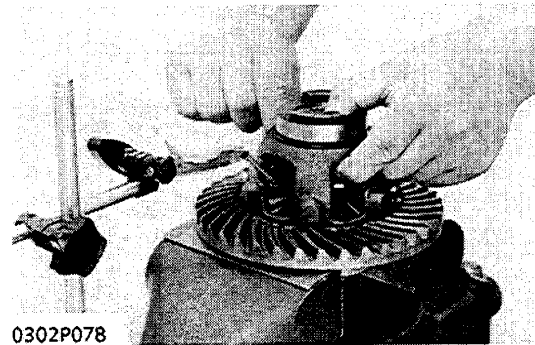

0302P078

Backlash between Differential Pinion and Differential Side Gear

1. Secure the differential case with a vise.
2. Set the dial indicator (lever type) with its finger on the tooth of the differential side gear.
3. Press differential pinion and side gear against the differential case.
4. Hold the differential pinion and move the differential side gear to measure the backlash.
5. If the backlash exceeds the allowable limit, adjust with differential side gear shims.

Backlash between differential pinion and differential side gear	Factory spec.	0.1 to 0.3 mm 0.004 to 0.012 in.
	Allowable limit	0.4 mm 0.016 in.

■ **NOTE**

- Thickness of shims:
0.8 mm (0.0315 in.), 1.0 mm (0.0394 in.),
1.2 mm (0.0472 in.)

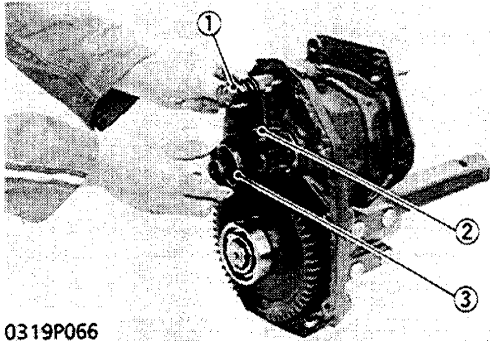
[2] AXLE CASE**DISASSEMBLING AND ASSEMBLING**

0319P066

Differential Lock Shift and Differential Lock Clutch**■ B1550-B1750-B1550HST-B1750HST**

1. Remove the spring (1).
2. Draw out the differential lock shift fork (2) and differential lock clutch (3).

- (1) Spring
(2) Differential Lock Shift Fork
(3) Differential Lock Clutch

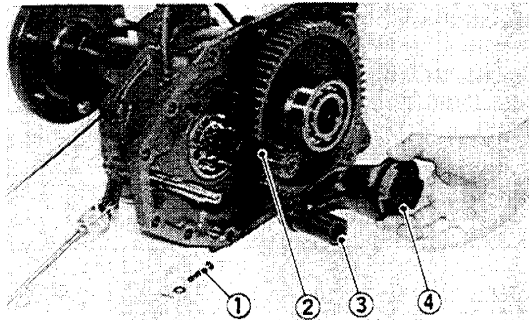

0302P079

■ B2150-B2150HST

1. Remove the cotter pin, and remove the clevis pin(1).
2. Draw out the differential lock clutch (4) and shift fork (3) from the differential gear shaft(2).

(When reassembling)

- When installing the differential lock shift fork, insert the clevis pin from the upper side to prevent it from falling.

- (1) Clevis Pin
(2) Differential Gear Shaft
(3) Differential Lock Shift Fork
(4) Differential Lock Clutch

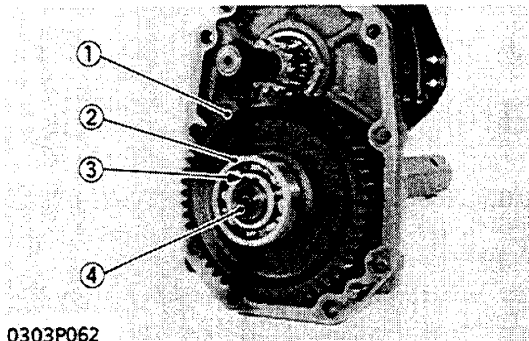

0303P062

55T Gear (B1550-B1750-B1550HST-B1750HST)

1. Remove the external snap ring (3), and remove the bearing (2).
2. Draw out the 55T gear (1) from the rear axle (4).

60T Gear (B2150-B2150HST)

1. Remove the bearing (2) from the rear axle, and remove the 60T gear (1).

- (1) Gear
(2) Bearing
(3) External Snap Ring
(4) Rear Axle

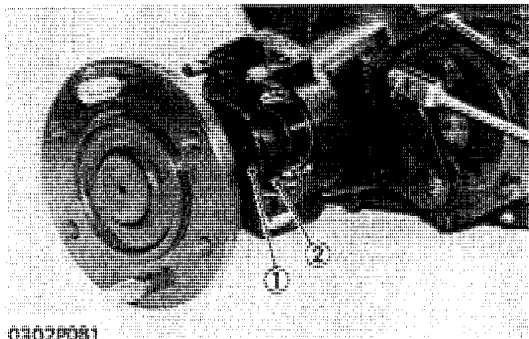

0302P081

Rear Axle

1. Remove the check chain bracket. (B2150-B2150HST)
2. Remove the oil seal (1).
3. Remove the internal snap ring (2), and tap out the rear axle to the outside of the axle case.

(When reassembling)**■ B2150-B2150HST**

Tightening torque	Check chain bracket mounting screw	62.8 to 72.5 N·m 6.4 to 7.4 kgf·m 46.3 to 53.5 ft·lbs
-------------------	------------------------------------	---

- (1) Oil Seal
(2) Internal Snap Ring

CONTENTS

TROUBLESHOOTING	S.5-1
SERVICING SPECIFICATIONS	S.5-1
CHECKING, DISASSEMBLING AND SERVICING	S.5-2
[1] BRAKE PEDAL	
CHECKING AND ADJUSTING	S.5-2
DISASSEMBLING AND ASSEMBLING	S.5-3
SERVICING	S.5-4
[2] BRAKE CASE	
DISASSEMBLING AND ASSEMBLING	S.5-4
SERVICING	S.5-5

TROUBLESHOOTING

Symptom	Probable Cause	Solution	Reference Page
Insufficient Braking Force	<ul style="list-style-type: none"> ● Brake pedal play excessive ● Brake shoe worn ● Brake drum worn ● Grease or oil on brake shoe ● Brake cam worn 	Adjust brake rod Replace Replace Replace Replace	S.5-2 S.5-5 S.5-5 S.5-4 S.5-4
Braking Force Uneven	<ul style="list-style-type: none"> ● Brake adjusted unevenly ● Brake shoe worn ● Brake drum worn 	Adjust brake rod Replace Replace	S.5-2 S.5-5 S.5-5
Brake Drags	<ul style="list-style-type: none"> ● Brake pedal play too small ● Brake pedal return spring weak or broken 	Adjust brake rod Replace	S.5-2 S.5-3
Heavy Brakes	<ul style="list-style-type: none"> ● Brake pedal, pedal shaft rusted ● Brake cam rusted 	Repair or Lubricate Repair or Lubricate	S.5-4 S.5-4

SERVICING SPECIFICATIONS

Item		Factory Specification	Allowable Limit
Brake Pedal	Free play B1550 B1750 B1550HST B1750HST	20 to 30 mm 0.79 to 1.18 in.	—
	B2150 B2150HST	25 to 35 mm 0.98 to 1.38 in.	—
Right and Left	Difference	Less than 4 mm 0.16 in.	—
Brake Pedal to Pedal Shaft	Clearance	0.070 to 0.384 mm 0.0028 to 0.0151 in.	0.5 mm 0.0197 in.
Pedal Shaft	O.D.	24.916 to 25.030 mm 0.9810 to 0.9854 in.	—
Brake Pedal	I.D.	25.100 to 25.300 mm 0.9882 to 0.9961 in.	—
Brake Shoe	Thickness B1550 B1750 B1550HST B1750HST	6.4 to 6.8 mm 0.2520 to 0.2677 in.	4.4 mm 0.1732 in.
	B2150 B2150HST	5.825 mm 0.2293 in.	4.8 mm 0.19 in.
Brake Drum	I.D. B1550 B1750 B1550HST B1750HST	95.00 to 95.10 mm 3.7402 to 3.7441 in.	97.0 mm 3.8189 in.
	B2150 B2150HST	120 mm 4.72 in	122 mm 4.80 in.

CHECKING, DISASSEMBLING AND SERVICING

[1] BRAKE PEDAL

CHECKING AND ADJUSTING

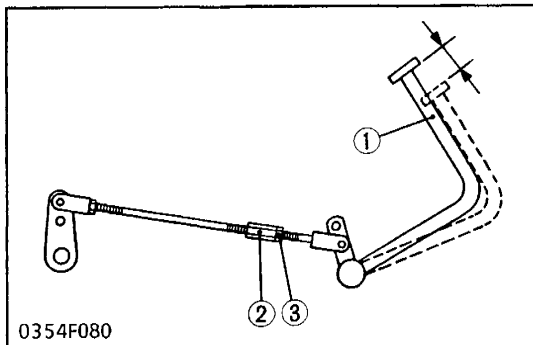

(1) Brake Pedal
(2) Turnbuckle
(3) Lock Nut

Brake Pedal Free Play (B1550-B1750-B1550HST-B1750HST)

1. Press each brake pedals five times with a force of 147 to 294 N (15 to 30 kgf, 33 to 66 lbs.).
2. Press the center of the pedal (1) at a force of 39 to 58 N (4 to 6 kgf, 9 to 13 lbs), and measure movement at the footrest of pedal.
3. If the measurement is not within the factory specifications, turn the turnbuckle (2) to adjust.
4. After adjustment, tighten the lock nut (3) firmly.

Brake pedal play	Factory spec.	20 to 30 mm 0.79 to 1.18 in.
------------------	---------------	---------------------------------

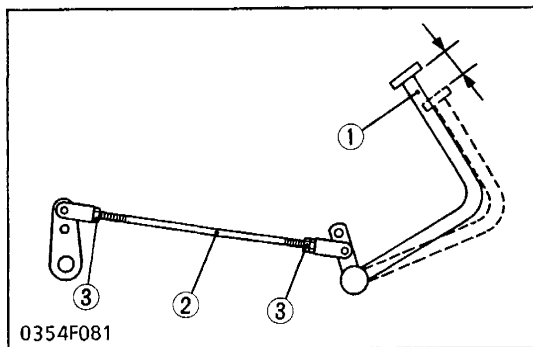

(1) Brake Pedal
(2) Brake Rod
(3) Lock Nut

Brake Pedal Free Play (B2150-B2150HST)

1. Press each brake pedals five times with a force of 147 to 294 N (15 to 30 kgf, 33 to 66 lbs).
2. Press the center of the pedal (1) at a force of 39 to 58N (4 to 6 kgf, 9 to 13 lbs), and measure movement at the footrest of pedal.
3. If the measurement is not within the factory specifications, turn the brake rod (2) to adjust.
4. After adjustment, tighten the lock nut (3) firmly.

Brake pedal play	Factory spec.	25 to 35 mm 0.98 to 1.38 in.
------------------	---------------	---------------------------------

⚠ CAUTION

- The difference between the right and left pedal plays must be less than 4 mm (0.16 in.).

■ NOTE

- After checking brake pedal free play, be sure to engage the parking brake lever fully and check to see that the brake pedals are securely locked.

DISASSEMBLING AND ASSEMBLING

Removing Brake Pedal

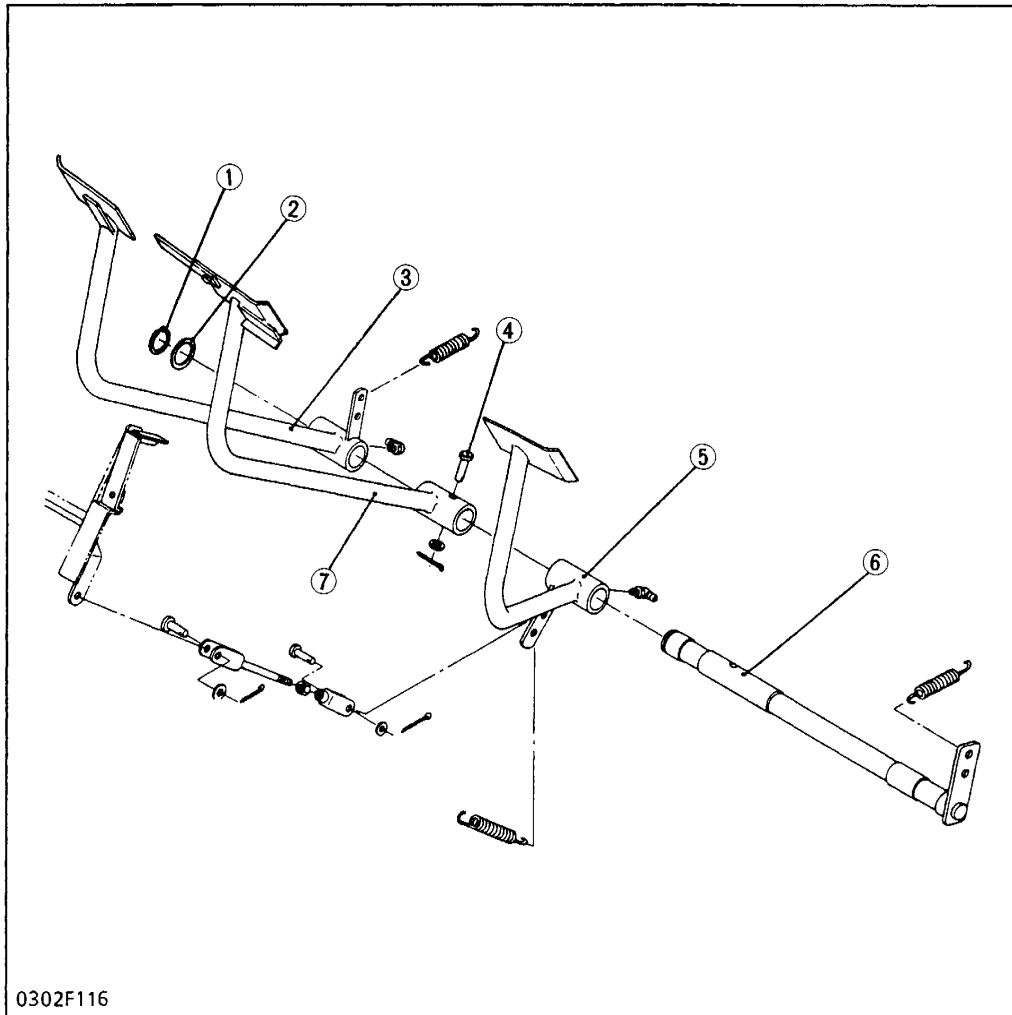

- (1) External Snap Ring
- (2) Collar
- (3) Brake Pedal RH
- (4) Clevis Pin
- (5) Clutch Pedal
- (6) Brake Pedal Shaft
- (7) Brake Pedal LH

0302F116

1. Remove the external snap ring (1) at the end of the brake pedal shaft (6).
2. Remove the clevis pin (4) of the brake pedal LH (7).
3. Pull the right and left brake pedals from the brake pedal shaft (6).
4. Tap out the brake pedal shaft (6) to the left, and remove it with the clutch pedal (5).

(When reassembling)

- After assembling, inject grease until it over flows from the ends of the pedals.

SERVICING

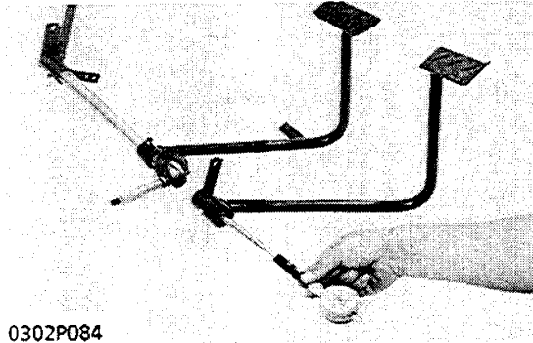

0302P084

Clearance between Brake Pedal Shaft and Pedal

1. Measure the brake pedal shaft O.D. with an outside micrometer.
2. Measure the brake pedal I.D. with a cylinder gauge. (Also, measure the clutch pedal I.D.)
3. If the clearance exceeds the allowable limit, replace it.

Clearance between brake pedal shaft and pedal	Factory spec.	0.070 to 0.384 mm 0.0028 to 0.0151 in.
	Allowable limit	0.5 mm 0.0197 in.

Brake pedal shaft O.D.	Factory spec.	24.916 to 25.030 mm 0.9810 to 0.9854 in.
Brake pedal I.D.	Factory spec.	25.100 to 25.300 mm 0.9882 to 0.9961 in.
Clutch pedal I.D.	Factory spec.	25.100 to 25.300 mm 0.9882 to 0.9961 in.

[2] BRAKE CASE

DISASSEMBLING AND ASSEMBLING

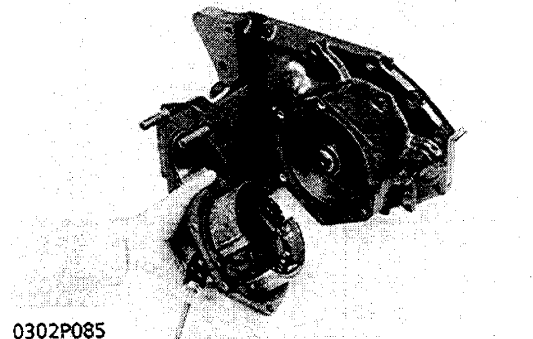

0302P085

Brake Cover

1. Remove the brake cover with brake shoe assembly.

(When reassembling)

- If oil sticks to the brake shoe surface, rub oil off the surface with the sandpaper.
- If oil is soaked in the brake shoe, replace it.
- Apply liquid gasket ("Three Bond 1215" or equivalent) to the both sides of the brake gasket.

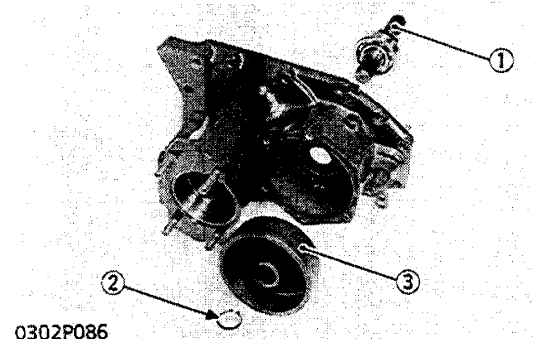

0302P086

- (1) Differential Gear Shaft (3) Brake Drum
(2) External Snap Ring

Brake Drum and Differential Gear Shaft

1. Remove the external snap ring (2), and remove the brake drum (3) from the axle case.
2. Tap out the differential gear shaft (1) inward from the outside of the case.

SERVICING

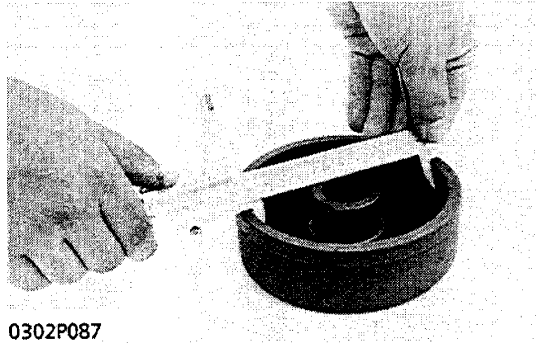

0302P087

Brake Drum Wear

1. Measure the brake drum I.D. with vernier calipers.
2. If the measurement exceeds the allowable limit, replace it.

■ B1550-B1750-B1550HST-B1750HST

Brake drum I.D	Factory spec.	95.00 to 95.10 mm 3.7402 to 3.7441 in.
	Allowable limit	97.0 mm 3.8189 in.

■ B2150-B2150HST

Brake drum I.D	Factory spec.	120 mm 4.72 in.
	Allowable limit	122 mm 4.80 in.

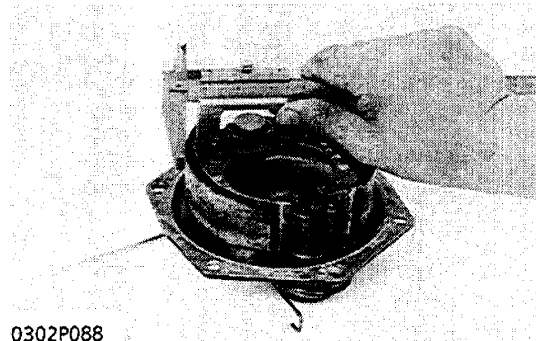

0302P088

Brake Shoe Wear

1. Measure the thickness of the brake shoe with vernier calipers.
2. If the wear exceeds the allowable limit, replace it.

■ NOTE

- If the shoe is carbonized or oil is soaked, replace.

■ B1550-B1750-B1550HST-B1750HST

Brake shoe thickness	Factory spec.	6.4 to 6.8 mm 0.2520 to 0.2677 in.
	Allowable limit	4.4 mm 0.1732 in.

■ B2150-B2150HST

Brake shoe thickness	Factory spec.	5.825 mm 0.2293 in.
	Allowable limit	4.8 mm 0.19 in.

CONTENTS

TROUBLESHOOTING	S.6-1
SERVICING SPECIFICATIONS	S.6-1
[2WD TYPE]	S.6-1
[4WD TYPE]	S.6-2
[B1550-B1550HST 4WD]	S.6-2
[B1750-B1750HST 4WD]	S.6-4
[BI-SPEED TURN]	S.6-5
[B2150-B2150HST 4WD]	S.6-6
TIGHTENING TORQUES	S.6-8
CHECKING, DISASSEMBLING AND SERVICING	S.6-10
CHECKING AND ADJUSTING	S.6-10
[2WD-4WD]	S.6-10
[BI-SPEED TURN]	S.6-12
[1] 2WD TYPE	
DISASSEMBLING AND ASSEMBLING	S.6-13
SERVICING	S.6-15
[2] 4WD TYPE	
[B1550-B1550HST 4WD]	
DISASSEMBLING AND ASSEMBLING	S.6-17
SERVICING	S.6-22
[B1750-B1750HST 4WD]	
DISASSEMBLING AND ASSEMBLING	S.6-25
SERVICING	S.6-30
[B2150-B2150HST 4WD]	
DISASSEMBLING AND ASSEMBLING	S.6-35
SERVICING	S.6-38
[B1550-B1550HST B1750-B1750HST-BI-SPEED TURN]	
DISASSEMBLING AND ASSEMBLING	S.6-44
SERVICING	S.6-50

TROUBLESHOOTING

Symptom	Probable Cause	Solution	Reference Page
Front Wheel Does Not Turn (4WD)	• Drive shaft broken	Replace	S.5-11, 14, 22, 29
	• Front wheel driving gears in transmission broken	Replace	S.3-29,60, 65
	• Front wheel driving gears in front axle gear case broken	Replace	S.6-20, 27, 36, 46
	• Universal joint broken	Replace	S.5-11, 14, 22, 29
	• Front wheel drive change lever spring pin broken	Replace	—
Front Wheels Wander to Right or Left	• Clearance between center pin and pin support excessive (2WD)	Replace	S.6-15
	• Clearance between center pin and bushing excessive (4WD)	Replace	S.6-24, 33
	• Improper toe-in adjustment (improper alignment)	Adjust	S.6-10
	• Knuckle shaft bushing worn (2WD)	Replace	S.6-16
	• Tire pressure uneven	Inflate	M.10-4, 5
Noise (4WD)	• Gear backlash excessive	Adjust or Replace	S.6-24, 32, 40
	• Gears broken	Replace	S.6-24, 32, 40
	• Bearing worn	Replace	S.6-24, 32, 40
	• Spiral bevel pinion shaft turning torque improperly adjusted	Adjust	S.6-23, 31, 42

SERVICING SPECIFICATIONS

[2WD TYPE]

Item		Factory Specification	Allowable Limit
Center Pin to Pin Support	Clearance (Except B2150, B2150HST)	0.02 to 0.27 mm 0.0008 to 0.0106 in.	0.70 mm 0.0276 in.
	Clearance (B2150, B2150HST)	0.05 to 0.25 mm 0.0020 to 0.0098 in.	0.70 mm 0.0276 in.
Center Pin	O.D. (Except B2150, B2150HST)	19.88 to 20.03 mm 0.7827 to 0.7886 in.	—
	O.D. (B2150, B2150HST)	24.90 to 25.00 mm 0.9803 to 0.9842 in.	—
Pin Support	I.D. (Except B2150, B2150HST)	20.05 to 20.15 mm 0.7894 to 0.7933 in.	—
	I.D. (B2150, B2150HST)	25.05 to 25.15 mm 0.9862 to 0.9901 in.	—

SERVICING SPECIFICATIONS (Continued)

[2WD TYPE]

Item		Factory Specification	Allowable Limit	
Knuckle Shaft to Bushing	Clearance (Except B2150, B2150HST)	0.076 to 0.164 mm 0.0030 to 0.0065 in.	0.50 mm 0.0197 in.	
	Clearance (B2150, B2150HST)	0.040 to 0.105 mm 0.0016 to 0.0041 in.	0.50 mm 0.0197 in.	
	Knuckle Shaft O.D. (Except B2150, B2150HST)	19.947 to 19.980 mm 0.7853 to 0.7866 in.		
	O.D. (B2150, B2150HST)	24.948 to 24.980 mm 0.9822 to 0.9835 in.		
	Bushings	I.D. (Except B2150, B2150HST)	20.056 to 20.111 mm 0.7896 to 0.7918 in.	
		I.D. (B2150, B2150HST)	25.020 to 25.053 mm 0.9850 to 0.9863 in.	
Front Wheel Alignment	Toe-in	0 to 5 mm 0 to 0.2 in.	—	
	Camber Angle	0.026 to 0.044 rad. 1.5° to 2.5°	—	
	Caster Angle (Except B2150, B2150HST)	0 to 0.026 rad. 0° to 1.5°	—	
	Caster Angle (B2150, B2150HST)	0 to 0.017 rad. 0° to 1°	—	
	King Pin Inclination	0.131 to 0.149 rad. 7.5° to 8.5°	—	
Front Wheel	Steering Angle (Except B2150, B2150HST)	0.91 to 0.94 rad. 52° to 54°	—	
	Steering Angle (B2150, B2150HST)	0.84 to 0.87 rad. 48° to 50°	—	
	Axial Sway	0 to 3 mm 0 to 0.118 in.	—	

[4WD TYPE]

[B1550-B1550HST 4WD]

Front Wheel Alignment	Toe-in	0 to 5 mm 0 to 0.197 in.	—
	Camber Angle	0.026 to 0.044 rad. 1.5° to 2.5°	—
	Caster Angle	0 to 0.026 rad. 0° to 1.5°	—
	King Pin Inclination	0.131 to 0.148 rad. 7.5° to 8.5°	—
Front Wheel	Steering Angle	0.77 to 0.80 rad. 44° to 46°	—
	Axial Sway	Less than 3 mm 0.118 in.	—

[B1550-B1550HST 4WD]

Item		Factory Specification	Allowable Limit
Differential Side Gear Boss to Differential Case Bore	Clearance	0.040 to 0.074 mm 0.0016 to 0.0029 in.	0.30 mm 0.0118 in.
Differential Side Gear Boss	O.D.	29.947 to 29.960 mm 1.1790 to 1.1795 in.	—
Differential Case Bore	I.D.	30.000 to 30.021 mm 1.1811 to 1.1819 in.	—
Ring Gear	I.D.	30.000 to 30.021 mm 1.1811 to 1.1819 in.	—
Differential Pinion Shaft to Differential Pinion	Clearance	0.016 to 0.045 mm 0.0006 to 0.0018 in.	0.30 mm 0.0118 in.
Differential Pinion Shaft	O.D.	13.973 to 13.984 mm 0.5501 to 0.5506 in.	—
Differential Pinion	I.D.	14.000 to 14.018 mm 0.5512 to 0.5519 in.	—
Differential Pinion to Differential Side Gear	Backlash	0.10 to 0.30 mm 0.0039 to 0.0118 in.	0.40 mm 0.016 in.
Adjusting Shim	Thickness	1.0 mm, 0.0394 in. 1.2 mm, 0.0472 in.	—
Spiral Bevel Pinion Shaft	Turning Torque	1.27 to 1.67 N-m 0.13 to 0.17 kgf-m 0.94 to 1.23 ft-lbs	—
Ring Gear to Spiral Bevel Pinion Shaft	Backlash	0.10 to 0.20 mm 0.0039 to 0.0079 in.	0.40 mm 0.016 in.
Adjusting Shim	Thickness	0.2 mm, 0.0079 in. 0.5 mm, 0.0197 in.	—
Center Pin to Center Pin Bushing	Clearance	0.070 to 0.270 mm 0.0028 to 0.0106 in.	0.70 mm 0.0276 in.
Center Pin	O.D.	19.88 to 20.03 mm 0.7827 to 0.7886 in.	—
Center Pin Bushing	I.D.	20.10 to 20.15 mm 0.7913 to 0.7933 in.	—
King pin to King Pin Bushing	Clearance	0.02 to 0.07 mm 0.0008 to 0.0028 in.	0.50 mm 0.0197 in.
King Pin	O.D.	19.98 to 20.00 mm 0.7866 to 0.7874 in.	—
King Pin Bushing	I.D.	20.02 to 20.05 mm 0.7881 to 0.7894 in.	—

SERVICING SPECIFICATIONS (Continued)**[B1750-B1750HST 4WD]**

Item		Factory Specification	Allowable Limit
Front Wheel Alignment	Toe-in	0 to 5 mm 0 to 0.197 in.	—
	Camber Angle	0.026 to 0.044 rad. 1.5° to 2.5°	—
	Caster Angle	0 to 0.026 rad. 0° to 1.5°	—
	King Pin Inclination	0.131 to 0.148 rad. 7.5° to 8.5°	—
Front Wheel	Steering Angle	0.77 to 0.80 rad. 44° to 46°	—
	Axial Sway	Less than 3 mm 0.118 in.	—
Differential Side Gear Boss to Differential Case Bore	Clearance	0.025 to 0.066 mm 0.0010 to 0.0026 in.	0.30 mm 0.0118 in.
	Differential Side Gear Boss O.D.	31.959 to 31.975 mm 1.2582 to 1.2589 in.	—
	Differential Case Bore I.D.	32.000 to 32.025 mm 1.2599 to 1.2608 in.	—
	Ring gear Bushing I.D.	32.000 to 32.025 mm 1.2599 to 1.2608 in.	—
Differential Pinion Shaft to Differential Pinion Bushing	Clearance	0.02 to 0.05 mm 0.0008 to 0.0020 in.	0.25 mm 0.0098 in.
	Differential Pinion Shaft O.D.	13.97 to 13.98 mm 0.5500 to 0.5504 in.	—
	Differential Pinion Bushing I.D.	14.00 to 14.02 mm 0.5512 to 0.5520 in.	—
Differential Pinion to Differential Side Gear	Backlash	0.10 to 0.30 mm 0.0039 to 0.0118 in.	0.40 mm 0.0157 in.
	Adjusting Shim Thickness	0.8 mm, 0.0315 in. 1.0 mm, 0.0394 in. 1.2 mm, 0.0472 in.	—
Spiral Bevel Pinion Shaft	Turning Torque	1.27 to 1.67 N-m 0.13 to 0.17 kgf-m 0.94 to 1.23 ft-lbs	—
Ring Gear to Spiral Bevel Pinion Shaft	Backlash	0.10 to 0.20 mm 0.0039 to 0.0079 in.	0.40 mm 0.0157 in.
	Adjusting Shim Thickness	0.2 mm, 0.0079 in. 0.5 mm, 0.0197 in.	—
Bevel Gears in Bevel Gear Case	Backlash	0.10 to 0.30 mm 0.0039 to 0.0118 in.	0.40 mm 0.0157 in.
	Adjusting Shim Thickness	0.2 mm, 0.0079 in. 0.3 mm, 0.0118 in. 0.5 mm, 0.0197 in.	— — —

[B1750-B1750HST 4WD]

Item		Factory Specification	Allowable Limit
Bevel Gears Front Axle Case Adjusting Shim	Backlash	0.10 to 0.20 mm 0.0039 to 0.0079 in.	0.40 mm 0.0157 in.
	Thickness	0.2 mm, 0.0079 in. 0.3 mm, 0.0118 in. 0.5 mm, 0.0197 in.	— — —
Center Pin to Center Pin Bushing Center Pin Center Pin Bushing	Clearance	0.070 to 0.270 mm 0.0028 to 0.0106 in.	0.70 mm 0.0276 in.
	O.D.	19.88 to 20.03 mm 0.7827 to 0.7886 in.	—
	I.D.	20.10 to 20.15 mm 0.7913 to 0.7933 in.	—
Knuckle Arm Support to Knuckle Arm Bushing Knuckle Arm Support Knuckle Arm Bushing	Clearance	0.022 to 0.110 mm 0.0009 to 0.0043 in.	0.40 mm 0.0157 in.
	O.D.	25.000 to 25.033 mm 0.9843 to 0.9855 in.	—
	I.D.	25.055 to 25.110 mm 0.9864 to 0.9886 in.	—
Knuckle Arm Support to Knuckle Arm Adjusting Shim	Clearance	0 to 0.20 mm 0 to 0.0079 in.	—
	Thickness	0.2 mm, 0.0079 in. 0.3 mm, 0.0118 in. 0.5 mm, 0.0197 in.	— — —

[B1550-B1750-B1550HST-B1750HST 4WD WITH BI-SPEED TURN]

Additional item is as follows.

Bi-speed Turn Clutch Disc	Thickness	2.1 to 2.2 mm 0.0827 to 0.0866	1.7 mm 0.0669 in.
Bi-speed Turn Friction Plate	Thickness	1.45 to 1.55 mm 0.0571 to 0.0610 in.	1.2 mm 0.0472 in.
	Displacement	0.2 to 0.6 mm 0.0079 to 0.0236 in.	0.1mm, 0.0039 in. or 0.8mm, 0.0315 in.
Bi-speed Turn Clutch	Dynamic Friction Torque	245.2 to 284.4 N·m 25 to 29 kgf·m 180.8 to 209.8 ft·lbs	—

SERVICING SPECIFICATIONS (Continued)**[B2150-B2150HST 4WD]**

Item		Factory Specification	Allowable Limit
Differential Pinion to Differential Side Gear Adjusting Shim	Backlash	0.02 to 0.20 mm 0.0008 to 0.0079 in.	0.40 mm 0.016 in.
	Gear Tooth Contact	More than 35%	—
	Thickness	0.8 mm, 0.031 in.	—
		1.0 mm, 0.039 in. 1.2 mm, 0.047 in.	— —
Spiral Bevel Pinion to Spiral Bevel Gear Side Adjusting Shim	Backlash	0.02 to 0.20 mm 0.0008 to 0.0079 in.	0.40 mm 0.016 in.
	Gear Tooth Contact	More than 35%	—
	Thickness	0.1 mm, 0.004 in.	—
		0.2 mm, 0.008 in.	—
0.5 mm, 0.020 in.		—	
Pinion Adjust Shim	Thickness	0.2 mm, 0.008 in. 0.3 mm, 0.012 in. 0.5 mm, 0.020 in.	— — —
13T Bevel Gear to 14T Bevel Gear Adjusting Shim	Backlash	0.10 to 0.30 mm 0.0039 to 0.0118 in.	0.40 mm 0.016 in.
	Thickness	0.2mm, 0.008 in.	—
		0.3 mm, 0.012 in.	—
0.5 mm, 0.020 in.		—	
17T Bevel Gear to 35T Bevel Gear Adjusting Shim	Backlash	0.10 to 0.30 mm 0.0039 to 0.0118 in.	0.40 mm 0.016 in.
	Thickness	0.2mm, 0.008 in.	—
		0.3 mm, 0.012 in.	—
0.5 mm, 0.020 in.		—	
Differential Case to Differential Side Gear Differential Side Gear Differential Case and Bushing	Clearance	0.025 to 0.075 mm 0.0010 to 0.0029 in.	0.30 mm 0.0118 in.
	O.D.	36.950 to 36.975 mm 1.4547 to 1.4557 in.	—
	I.D.	37.000 to 37.025 mm 1.4567 to 1.4576 in.	—

[B2150-B2150HST 4WD]

Item		Factory Specification	Allowable Limit
Differential Pinion Shaft to Differential Pinion Bushing	Clearance	0.016 to 0.054 mm 0.0007 to 0.0021 in.	0.30 mm 0.0118 in.
	Differential Pinion Shaft O.D.	15.973 to 15.984 mm 0.6289 to 0.6293 in.	—
	Bushing I.D.	16.000 to 16.027 mm 0.6300 to 0.6310 in.	—
Spiral Bevel Pinion Shaft		Turning Torque	1.27 to 1.67 N·m 0.13 to 0.17 kgf·m 0.94 to 1.23 ft-lbs
Knuckle Arm to Knuckle Arm Support	Clearance	0 to 0.2 mm 0 to 0.008 in.	—
	Adjusting Shim Thickness	0.2 mm, 0.008 in.	—
		0.3 mm, 0.012 in. 0.5 mm, 0.020 in.	— —
Center Pin to Bushing	Clearance	0.100 to 0.202 mm 0.004 to 0.008 in.	0.70 mm 0.0276 in.
	O.D.	24.948 to 25.000 mm 0.9822 to 0.9842 in.	—
	I.D.	25.100 to 25.150 mm 0.9882 to 0.9901 in.	—
Knuckle Arm Support to Bushing	Clearance	0.022 to 0.110 mm 0.0009 to 0.0043 in.	0.40 mm 0.0157 in.
	Knuckle Arm Support O.D.	25.000 to 25.033 mm 0.9843 to 0.9855 in.	—
	Bushing I.D.	25.055 to 25.100 mm 0.9864 to 0.9886 in.	—
Front Wheel Alignment	Toe-in	0 to 5 mm 0 to 0.197 in.	—
	Camber Angle	0.026 to 0.044 rad. 1.5° to 2.5°	—
	Caster Angle	0 to 0.017 rad. 0° to 1°	—
	Kingpin Inclination	0.166 to 0.183 rad. 9.5° to 10.5°	—
Front Wheel	Steering Angle	0.84 to 0.87 rad. 48° to 50°	—
	Axial Sway	0 to 3 mm 0 to 0.118 in.	—

TIGHTENING TORQUES

Tightening torques of screws and nuts on the table below are especially specified.
(For general use screws and nuts: See page S.G-4).

[2WD TYPE]

[B1550-B1750-B1550HST-B1750HST]

Item	N·m	kgf·m	ft-lbs
Front wheel mounting screw	73.5 to 107.9	7.5 to 11.0	54.2 to 79.6
Slotted nut (King Pin)	82.4 to 86.3	8.4 to 8.8	60.8 to 63.7
Slotted nut (Tie rod end)	17.7 to 34.3	1.8 to 3.5	13.0 to 25.3
Knuckle arm mounting bolt	20.6 to 29.4	2.1 to 3.0	15.2 to 21.7

[B2150-B2150HST]

Front wheel mounting screw	77.4 to 90.2	7.9 to 9.2	57.2 to 66.5
Front wheel hub slotted nuts	117.6 to 156.8	12 to 16	86.8 to 115.7
Knuckle arm mounting bolts and nuts	77.4 to 90.2	7.9 to 9.2	57.2 to 66.5
Tie rod end slotted nuts	48.1 to 55.9	4.9 to 5.7	35.5 to 41.2
Center pin slotted nut	Less than 9.8	Less than 1.0	Less than 7.2
Lock plate mounting nuts	17.7 to 19.6	1.8 to 2.0	13.0 to 14.5

[4WD TYPE]

[B1550-B1550HST]

Front wheel mounting screw	73.5 to 107.9	7.5 to 11.0	54.2 to 79.6
Slotted nut (Tie rod end)	17.7 to 34.3	1.8 to 3.5	13.0 to 25.3
Knuckle arm mounting screw	39.2 to 64.7	4.0 to 6.6	28.9 to 47.7
Gear case cover mounting screw	18.6 to 32.4	1.9 to 3.3	13.7 to 23.9
Spacer mounting screw	18.6 to 32.4	1.9 to 3.3	13.7 to 23.9
Front axle case mounting nut			
M8	23.5 to 27.5	2.4 to 2.8	17.4 to 20.3
M10	48.1 to 55.9	4.9 to 5.7	35.4 to 41.2
Ring gear mounting screw	29.4 to 34.3	3.0 to 3.5	21.7 to 25.3

[B1750-B1750HST]

Front wheel mounting nut	73.5 to 107.9	7.5 to 11.0	54.2 to 79.6
Slotted nut (Tie rod end)	17.7 to 34.3	1.8 to 3.5	13.0 to 25.3
Bevel gear case mounting screw	18.6 to 32.4	1.9 to 3.3	13.7 to 23.9
Knuckle arm mounting screw	39.2 to 64.7	4.0 to 6.6	28.9 to 47.7
Knuckle arm support mounting screw	18.6 to 32.4	1.9 to 3.3	13.7 to 23.9
Bevel support cover mounting screw	18.6 to 32.4	1.9 to 3.3	13.7 to 23.9
Front axle cover mounting screw	44.1 to 63.7	4.5 to 6.5	32.5 to 47.0
Spacer mounting screw	18.6 to 32.4	1.9 to 3.3	13.7 to 23.9
Front axle mounting screw	44.1 to 63.7	4.5 to 6.5	32.5 to 47.0
Ring gear mounting screw	29.4 to 34.3	3.0 to 3.5	21.7 to 25.3

[B1550-B1750-B1550HST-B1750HST BI-SPEED TURN]

Item	N·m	kgf·m	ft-lbs
Front wheel mounting screw	73.5 to 107.9	7.5 to 11.0	54.2 to 79.6
Slotted nut (Tie rod end)	17.7 to 34.3	1.8 to 3.5	13.0 to 25.3
Knuckle arm mounting screw	39.2 to 64.7	4.0 to 6.6	28.9 to 47.7
Gear case cover mounting screw (B1550-B1550HST)	18.6 to 32.4	1.9 to 3.3	13.7 to 23.9
Bevel gear case mounting screw (B1750-B1750HST)	18.6 to 32.4	1.9 to 3.3	13.7 to 23.9
Spacer mounting screw	18.6 to 32.4	1.9 to 3.3	13.7 to 23.9
Front axle case mounting nut (B1550-B1550HST)			
M8	23.5 to 27.5	2.4 to 2.8	17.4 to 20.3
M10	48.1 to 55.9	4.9 to 5.7	35.4 to 41.2
Knuckle arm support mounting screw (B1750-B1750HST)	18.6 to 32.4	1.9 to 3.3	13.7 to 23.9
Bevel support cover mounting screw(↑)	18.6 to 32.4	1.9 to 3.3	13.7 to 23.9
Front axle cover mounting screw (↑)	44.1 to 63.7	4.5 to 6.5	32.5 to 47.0
Front axle arm mounting screw (↑)	44.1 to 63.7	4.5 to 6.5	32.5 to 47.0
Front diff. shaft mounting screw	29.4 to 34.3	3.0 to 3.5	21.7 to 25.3

[B2150-B2150HST 4WD]

Center pin slotted nut	Less than 9.8	Less than 1.0	Less than 7.2
Lock plate mounting nuts	17.7 to 19.6	1.8 to 2.0	13.0 to 14.5
Tie rod end slotted nuts	48.1 to 55.9	4.9 to 5.7	35.5 to 41.2
Front wheel mounting nuts	77.4 to 90.2	7.9 to 9.2	57.2 to 66.5
Bevel gear case mounting screw and nut	77.4 to 90.2	7.9 to 9.2	57.2 to 66.5
Knuckle arm mounting nuts	48.1 to 55.9	4.9 to 5.7	35.5 to 41.2
Knuckle arm support mounting screw	23.5 to 27.5	2.4 to 2.8	17.4 to 20.3
Bevel support cover mounting screws	23.5 to 27.5	2.4 to 2.8	17.4 to 20.3
Front axle cover mounting screws	48.1 to 55.9	4.9 to 5.7	35.5 to 41.2
Spacer mounting screws	48.1 to 55.9	4.9 to 5.7	35.5 to 41.2
Front axle arm mounting screws and nuts	44.1 to 63.7	4.5 to 6.5	32.6 to 47.0

CHECKING, DISASSEMBLING AND SERVICING

CHECKING AND ADJUSTING

[2WD 4WD]

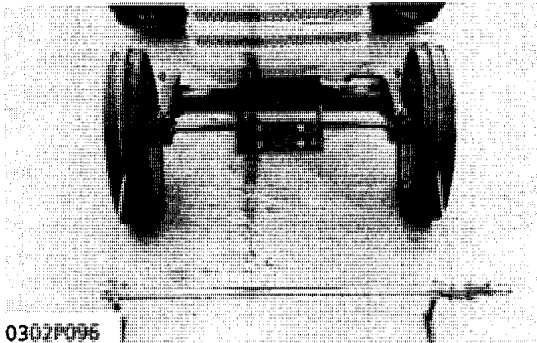

Toe-in

1. Inflate the tires to the specified pressure.
2. Turn the front wheels straight ahead.
3. Measure the distance between the centers of front wheels at front and rear.
4. If the measurement exceeds the factory specification, adjust by changing the tie rod length.

Toe-in	Factory spec.	2WD	0 to 5 mm 0 to 0.197 in.
		4WD	

■ NOTE

- For specified pressures, refer to the item on "TIRES" in the mechanism block (Page M10.-1)
- After toe-in adjustment, secure the tie rod with lock nut. (Tightening torque: 68.6 to 88.2 N·m, 7.0 to 9.0 kgf·m, 50.7 to 65.1 ft-lbs.)

Front Wheel Steering Angle

1. Inflate the tires to the specified pressure.
2. Place the turning radius gauge under the front wheels.
3. Steer the wheels to the extreme right and left, and measure the steering angle.
4. If the angle is not within the factory specifications, adjust with the adjusting bolt (1).

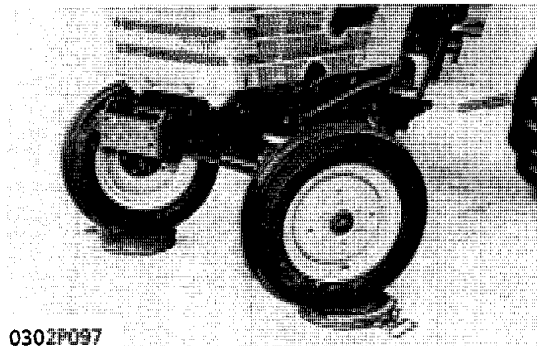

Front wheel steering angle	Factory spec.	B1550, B1750, B1550HST, B1750HST	2WD	0.91 to 0.94 rad. 52° to 54°
		B1550, B1550HST,	4WD	0.77 to 0.80 rad. 44° to 46°
		B1750, B1750HST,		0.91 to 0.94 rad. 52° to 54°
		B2150, B2150HST,	2WD 4WD	0.84 to 0.87 rad. 48° to 50°

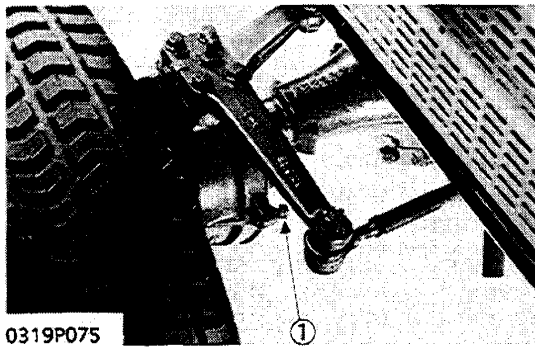

■ NOTE

- For right turn, adjust the screw on the gear case RH, and for left turn, adjust the screw (1) on the gear case LH. (B1550, B1550HST 4WD)
- For right turn, adjust the front screw (2) on the front axle case LH, and for left turn, adjust the rear screw (3) on the front axle case LH. (B1750, B1750HST 4WD)
- After adjustment, secure the screw with the lock nut.

- (1) Screw
- (2) Screw

- (3) Screw

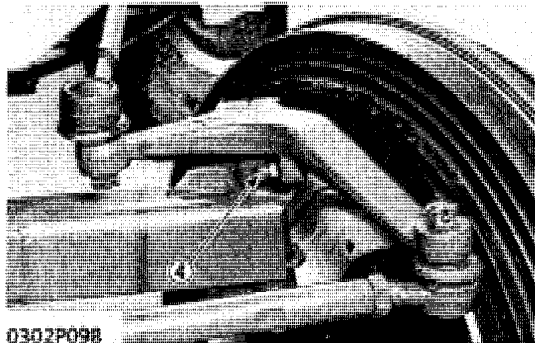
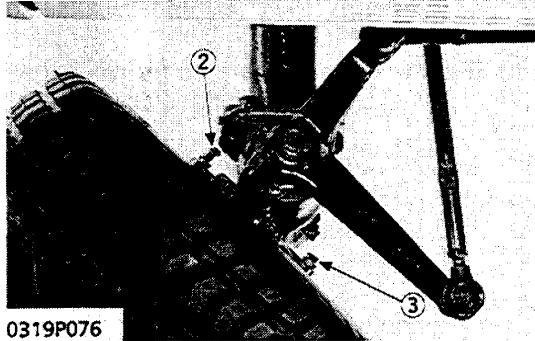

■ NOTE

- Adjust the steering angle with the adjusting bolt at the right side when the steering wheel is turned counter clockwise, and adjust with the adjusting bolt at the left side when it is turned clockwise.
- After adjustment, secure the adjusting bolts with the lock nut.

- (4) Adjusting Bolt

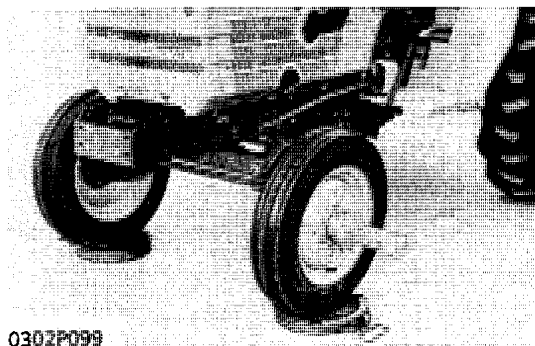

Camber Angle, Caster Angle and Kingpin Inclination

1. Inflate the tires to the specified pressure.
2. Place the turning radius gauge under the front wheels.
3. Remove the front wheel cap and set the gauge to measure camber angle, caster angle and kingpin inclination.

Camber angle	Factory spec.	All	2WD	0.026 to 0.044 rad. 1.5° to 2.5°
			4WD	
Caster angle	Factory spec.	B1550, B1750, B1550HST, B1750HST	2WD	0 to 0.017 rad. 0° to 1°
			4WD	
		B2150, B2150HST	2WD	0 to 0.026 rad. 0° to 1.5°
			4WD	
Kingpin inclination	Factory spec.	B1550, B1750, B1550HST, B1750HST	2WD	0.131 to 0.149 rad. 7.5° to 8.5°
			4WD	
		B2150, B2150HST	2WD	0.131 to 0.149 rad. 7.5° to 8.5°
			4WD	

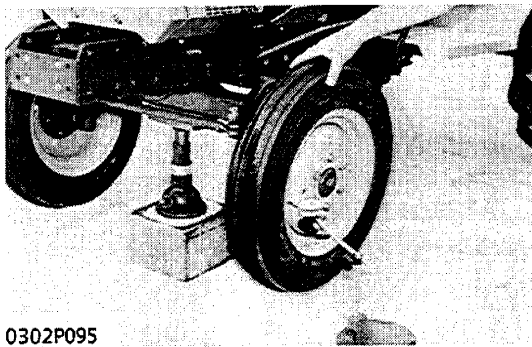

0302P095

Sway of Front Wheel

1. Jack up the front of tractor.
2. Set a dial indicator on the rim, and slowly turn the tires to measure the sway.
3. If the sway exceeds the factory specification, check the bearing in the front wheel hub and the rim.

Front wheel sway	Factory spec.	2WD	0 to 3 mm 0 to 0.118 in.
		4WD	

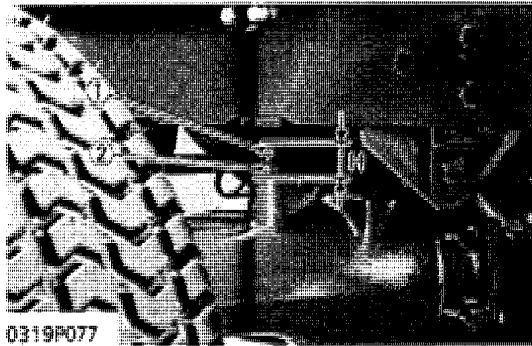

0319P077

(1) Screw

(2) Lock Nut

Rocking Angle (4WD)

1. Measure the height (H) of each adjusting screw on the left and right front axle cases (B1550, B1550HST 4WD) or front axle arm (B1750, B1750HST).
2. If the measurement is not within the factory specification, adjust with the screw(1).

Height of adjusting screw	Factory spec.	B1550, B1550HST 4WD	24 mm 0.94 in.
		B1750, B1750HST 4WD	25 mm 0.98 in.

NOTE

- After adjustment, secure the adjusting screw with the lock nut (2).
- When the wheels are turned straight ahead, the tie rod can be inclined 0.14 rad. (8 deg.) up and down from level.

CHECKING AND ADJUSTING (Continued)

[BI-SPEED TURN]

Toe-in

Refer to S.6-10.

Toe-in	Factory spec.	B1550, B1750 B1550HST B1750HST Bi-speed turn	0 to 5 mm 0 to 0.197 in.
--------	---------------	---	-----------------------------

Front Wheel Steering Angle

Refer to S.6-10.

Front wheel steering angle	Factory spec.	B1550, B1550HST Bi-speed turn	0.77 to 0.80 rad. 44° to 46°
		B1750, B1750HST Bi-speed turn	0.91 to 0.94 rad. 52° to 54°

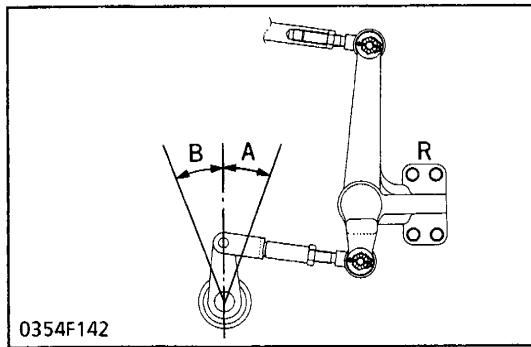

NOTE

- If power steering is equipped, measure the turning radius after disconnecting the tie rod from the knuckle arm to feel the steering cam touching.

Bi-speed Turn Shift Lever Linkage

1. Turn the front wheels straight ahead. This is the center position of wheels.
2. Place the turning radius gauge under the front wheels.
3. Be sure that the front wheels is set in the center position again.
4. Steer the wheels to the right till the steering cam in the bi-speed turn case touches the shift roller for shifting the bi-speed turn shift fork, (Steering wheel feeling becomes to be a little heavier) and measure this right steering angle (A).
5. Steer the wheels to the left till the steering cam touches the shift roller for shifting the bi-speed turn shift fork and measure this left steering angle (B).
6. Adjust these angles with the shift linkage so that A (allowance $A-2^\circ$ to $A+2^\circ$) is equal to B (allowance $B-2^\circ$ to $B+2^\circ$).
7. After adjustment, be sure to tighten the lock nut and drive the tractor to check this operation. (If no turning radius gauge, jack up the front of tractor and measure the steering wheel turning radius on the steering.)

[1] 2WD TYPE

DISASSEMBLING AND ASSEMBLING

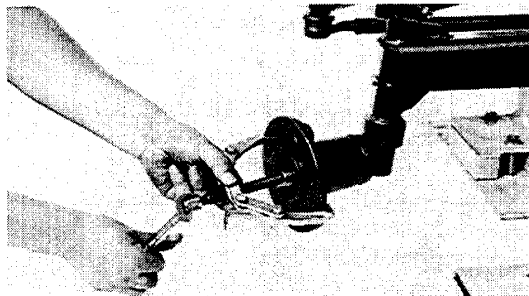

0302P089

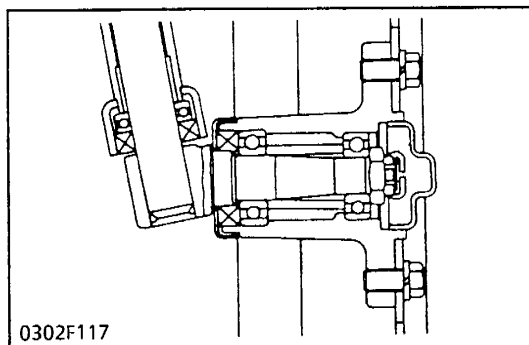

0302F117

Front Wheel Hub

1. Remove the front wheels.
2. Remove the front wheel caps.
3. Remove the cotter pin and slotted nuts.
4. Remove the front wheel hub with a puller.

(When reassembling)

Tightening torque	Front wheel mounting screw	B1550, B1750 B1550HST B1750HST	73.5 to 107.9 N·m 7.5 to 11.0 kgf·m 54.2 to 79.6 ft-lbs
		B2150 B2150HST	77.4 to 90.2 N·m 7.9 to 9.2 kgf·m 57.2 to 66.5 ft-lbs
Tightening torque	Slotted nut	B1550, B1750 B1550HST B1750HST	82.4 to 86.3 N·m 8.4 to 8.8 kgf·m 60.8 to 63.7 ft-lbs
		B2150 B2150HST	118 to 157 N·m 12 to 16 kgf·m 86.8 to 115.7 ft-lbs

(When reassembling)

- Bend the cotter pin as shown in the figure.

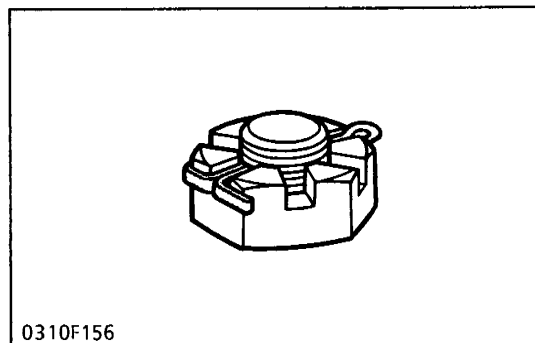

0310F156

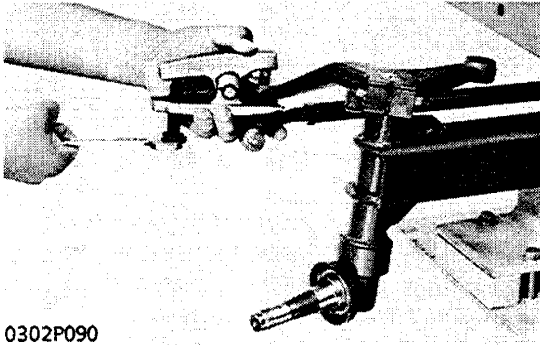

0302P090

Tie Rod and Knuckle Arm

1. Pull out the cotter pins, and remove the slotted nuts.
2. Remove the tie rod with the tie rod end lifter. (Code No. 07909-39021)
3. Remove the knuckle arm.

(When reassembling)

- Lift the knuckle shaft first to eliminate any gap in the vertical direction before tightening the knuckle arm bolts and nuts.

Tightening torque	Knuckle arm mounting bolt and nut	B1550, B1750 B1550HST B1750HST	20.6 to 29.4 N·m 2.1 to 3.0 kgf·m 15.2 to 21.7 ft·lbs
		B2150 B2150HST	77.4 to 90.2 N·m 7.9 to 9.2 kgf·m 57.2 to 66.5 ft·lbs
	Slotted nut for tie rod end	B1550, B1750 B1550HST B1750HST	17.7 to 34.3 N·m 1.8 to 3.5 kgf·m 13.0 to 25.3 ft·lbs
		B2150 B2150HST	48.1 to 55.9 N·m 4.9 to 5.7 kgf·m 35.5 to 41.2 ft·lbs

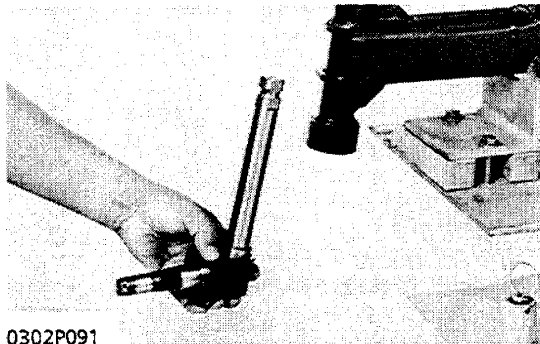

0302P091

Knuckle Shaft

1. Remove the knuckle shaft from the front axle assembly.

(When reassembling)

- Install the thrust bearing (1) in its proper direction.

■ IMPORTANT

- After reassembling, be sure to adjust the clearance between the front axle and knuckle arm. (See page S.6-16)

(1) Thrust Bearing

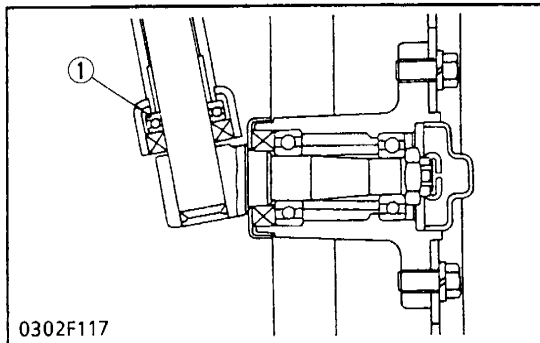

0302F117

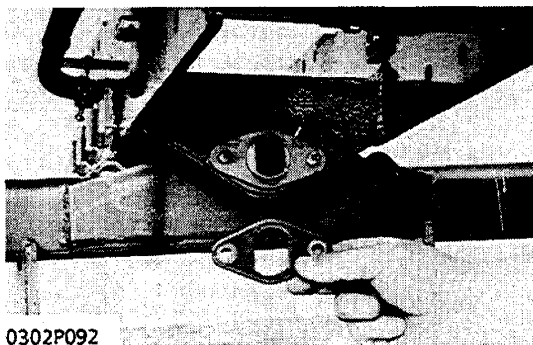

0302P092

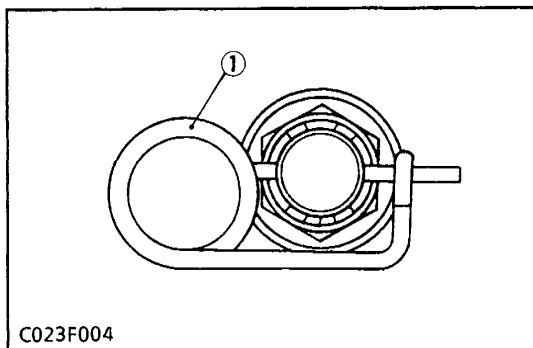

C023F004

Separation of Front Axle and Front Axle Frame

1. Remove the set spring.
2. Remove the slotted nut.
3. Remove the lock plate, and pull out the center pin forward.
4. Separate the front axle from the front axle frame.

(When reassembling)

- After reassembling the center pin, apply grease until it overflows from the end.

Tightening torque	Slotted nut	Less than 9.8 N·m 1.0 kgf·m 7.23 ft-lbs
	Lock plate mounting nut	17 to 19.6 N·m 1.8 to 2.0 kgf·m 13.0 to 14.5 ft-lbs

NOTE

- Tighten the slotted nut to 9.8 N·m (1.0 kgf·m, 7.23 ft-lbs). If the slot and pin hole do not meet, loosen the nut until they do meet, and then install the set spring.
- When installing the set spring (1), insert it from the left side, as shown in figure.

(1) Set Spring

SERVICING

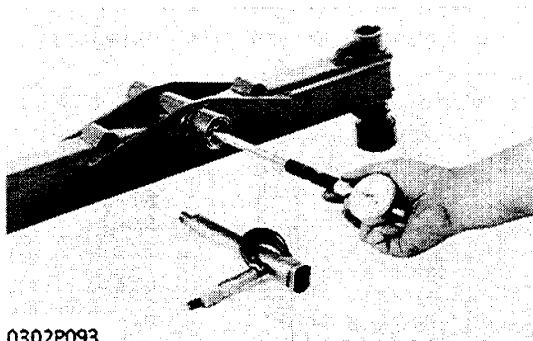

0302P093

Clearance between Center Pin and Pin Support

1. Measure the center pin O.D. with an outside micrometer.
2. Measure the pin support I.D. of the front axle with a cylinder gauge.
3. If the clearance exceeds the allowable limit, replace it.

Clearance between center pin and pin support	Factory spec.	B1550, B1750 B1550HST B1750HST	0.02 to 0.27 mm 0.0080 to 0.0106 in.
		B2150 B2150HST	0.05 to 0.25 mm 0.0020 to 0.0098 in.
	Allowable limit		0.70 mm 0.0276 in.

Center pin O.D.	Factory spec.	B1550, B1750 B1550HST B1750HST	19.88 to 20.03 mm 0.7827 to 0.7836 in.
		B2150 B2150HST	24.90 to 25.00 mm 0.9803 to 0.9842 in.
Pin support I.D.	Factory spec.	B1550, B1750 B1550HST B1750HST	20.05 to 20.15 mm 0.7894 to 0.7918 in.
		B2150 B2150HST	25.05 to 25.15 mm 0.9862 to 0.9901 in.

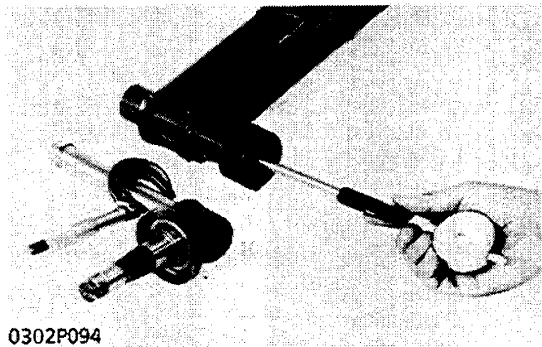

0302P094

Clearance between Knuckle Shaft and Bushing

1. Measure the knuckle shaft O.D. at several points with an outside micrometer. (The knuckle shaft tends to show concentrated wear.)
2. Similarly, measure the knuckle shaft bushing I.D. with a cylinder gauge.
3. If the clearance exceeds the allowable limit, replace.

Clearance between knuckle shaft and bushing	Factory spec.	B1550, B1750 B1550HST B1750HST	0.076 to 0.164 mm 0.030 to 0.0065 in.
		B2150 B2150HST	0.040 to 0.105 mm 0.0016 to 0.0041 in.
	Allowable limit		0.50 mm 0.0197 in.

Knuckle shaft O.D.	Factory spec.	B1550, B1750 B1550HST B1750HST	19.947 to 19.980 mm 0.7853 to 0.7886 in.
		B2150 B2150HST	24.948 to 24.980 mm 0.9822 to 0.9835 in.
Bushing I.D.	Factory spec.	B1550, B1750 B1550HST B1750HST	20.056 to 20.111 mm 0.7896 to 0.7918 in.
		B2150 B2150HST	25.020 to 25.053 mm 0.9850 to 0.9863 in.

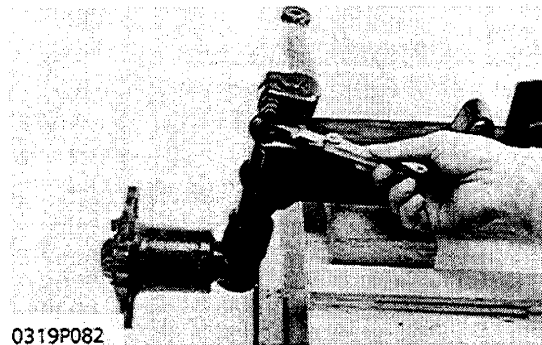

0319P082

Clearance between Front Axle and Knuckle Arm

1. Measure the clearance between the front axle and knuckle arm.
2. If the clearance is not within the factory specifications, adjust with the shim.

Clearance between front axle and knuckle arm	Factory spec.	0.05 to 0.20 mm 0.0020 top 0.0079 in.
--	---------------	--

(Reference)

- Thickness of shims: 0.5 mm (0.0197 in.)
1.0 mm (0.0394 in.)
- Tightening torque: 2.1 to 3.0 kgf-m

Toe-in, Front Wheel Steering Angle

Refer to S.6-10.

Camber Angle, Caster Angle, Kingpin Inclination, Sway of Front Wheel

Refer to S.6-11, 12.

[2] 4WD TYPE

[B1550-B1550HST 4WD]

DISASSEMBLING AND ASSEMBLING

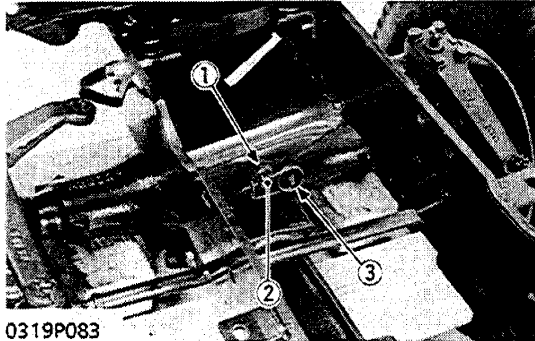

0319P083

- (1) Slotted Nut
- (2) Center pin
- (3) Set Spring

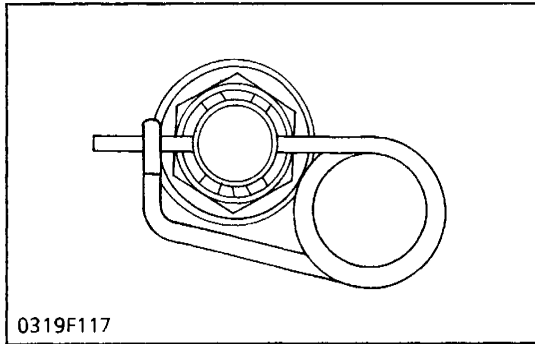

0319F117

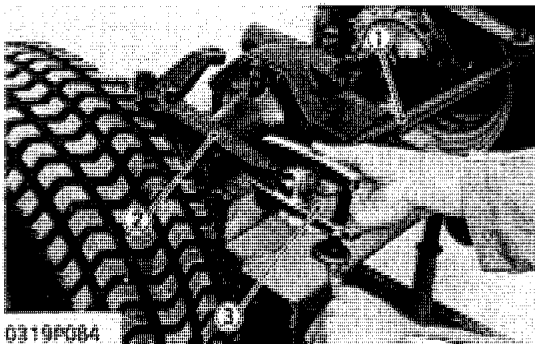

0319P084

- (1) Tie Rod
- (2) Knuckle Arm
- (3) Tie Rod End Lifter

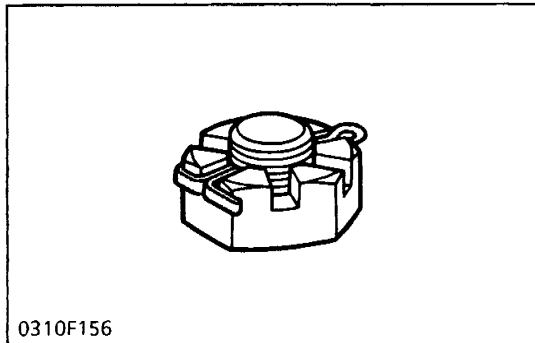

0310F156

Separating Front Axle

1. Remove the set spring (3).
2. Remove the slotted nut (1), and pull out the center pin (2).
3. Separate the front axle from the front axle frame.

(When reassembling)

- Use care not to damage the O-ring.

■ NOTE

- Tighten the slotted nut to 9.8 N-m (1.0 kgf-m, 7.23 ft-lbs). If the slot and pin hole do not meet, loosen the nut until they do meet, and then install the set spring.
- When installing the set spring, insert it as shown in the figure.

Tie Rod

1. Pull out the cotter pin, and remove the slotted nut.
2. Remove the tie rod (1) from the knuckle arm(2) with the tie rod end lifter (3) (Code No; 07909-39021).
3. Remove the front wheel.

(When reassembling)

- Bend the cotter pin as shown in the figure.

Tightening torque	Slotted nut for tie rod end	17.7 to 34.3 N·m 1.8 to 3.5 kgf·m 13.0 to 25.3 ft-lbs
	Front wheel mounting nut	73.5 to 107.9 N·m 7.5 to 11.0 kgf·m 54.2 to 79.6 ft-lbs

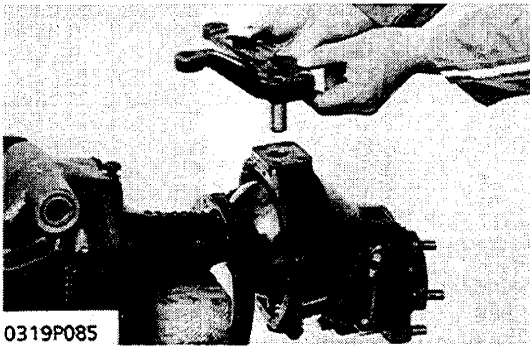

0319P085

Gear Case

1. Remove the screws (14), dust cover (15), dust seal (16), dust seal holder (17) and gasket (18).
2. Remove the knuckle arm mounting screws and king pin 1 lock screw (2).
3. Pull out king pin 1 (5) with the knuckle arm (1).
4. Remove king pin 2 lock screw (1), and pull out king pin 2 (12).
5. Separate the gear case (7) from the front axle case.

(When reassembling)

- Be sure to replace the knuckle arm gasket (6) with a new one.
- Be sure to replace the dust cover gasket (18) with a new one.
- Install king pin 1 and 2 to the gear case, noting the O-rings (4), (13).

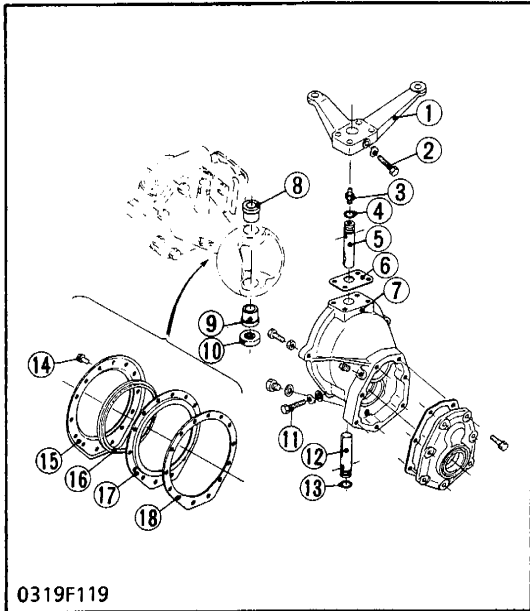

0319F119

Tightening torque	Knuckle arm mounting screw	39.2 to 64.7 N·m 4.0 to 6.6 kgf·m 28.9 to 47.7 ft-lbs
-------------------	----------------------------	---

- | | |
|---------------------------|----------------------------|
| (1) Knuckle Arm | (10) Thrust Ball Bearing |
| (2) King Pin 1 Lock Screw | (11) King Pin 2 Lock Screw |
| (3) Grease Nipple | (12) King Pin 2 |
| (4) O-ring | (13) O-ring |
| (5) King Pin 1 | (14) Screw |
| (6) Knuckle Arm Gasket | (15) Dust Cover |
| (7) Gear Case | (16) Dust Seal |
| (8) King Pin Bushing | (17) Dust Seal Holder |
| (9) King Pin Bushing | (18) Dust Cover Gasket |

Gear Case Cover

1. Remove the gear case cover (1).

(When reassembling)

- Apply liquid gasket (Three Bond 1102 or equivalent) to the both sides of new gasket.

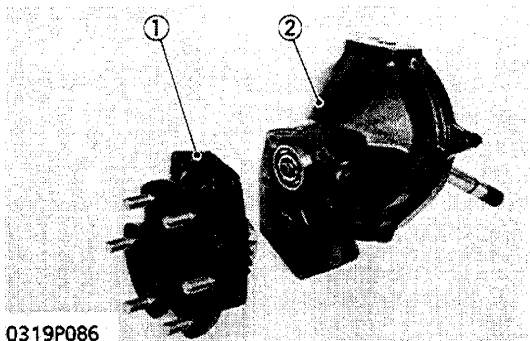

0319P086

(1) Gear Case Cover (1) Gear Case

Tightening torque	Gear case cover mounting screw	18.6 to 32.4 N·m 1.9 to 3.3 kgf·m 13.7 to 23.9 ft-lbs N·m
-------------------	--------------------------------	---

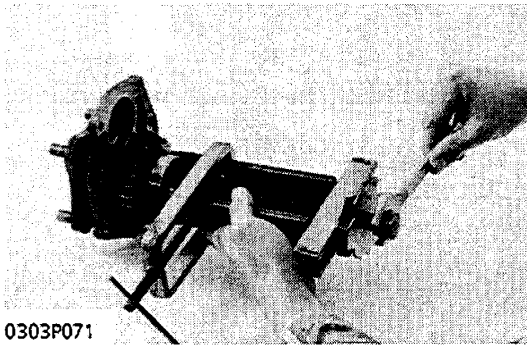

0303P071

Front Wheel Hub

1. Remove the bearing (1) and 25T gear (2) with a special-use puller set (Code No; 07916-09032).
2. Remove the external snap ring (3), tap out the front wheel hub (6).

(When reassembling)

- Use care not to damage the oil seal (5).

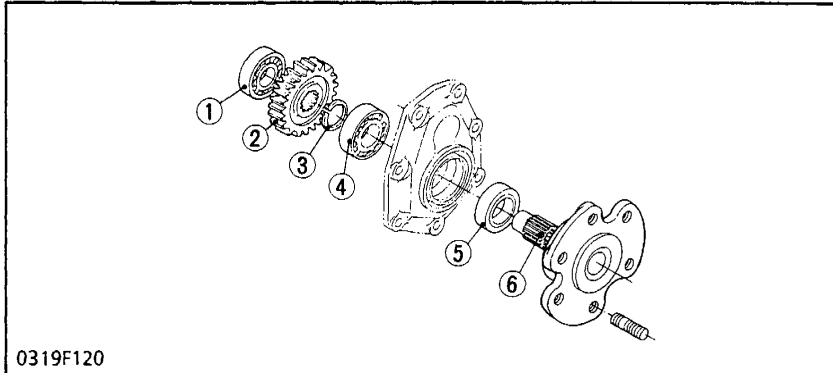

0319F120

- (1) Bearing
- (2) 25T gear
- (3) External Snap Ring
- (4) Bearing
- (5) Oil Seal
- (6) Front Wheel Hub

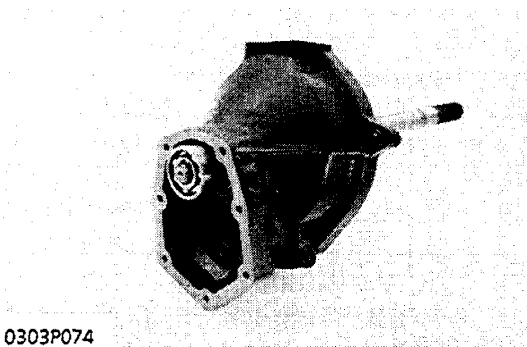

0303P074

Universal Joint

1. Remove the external snap ring (5), and remove the bearing (4) with a puller.
2. Remove the 12T gear (3), and tap out the joint shaft (13).

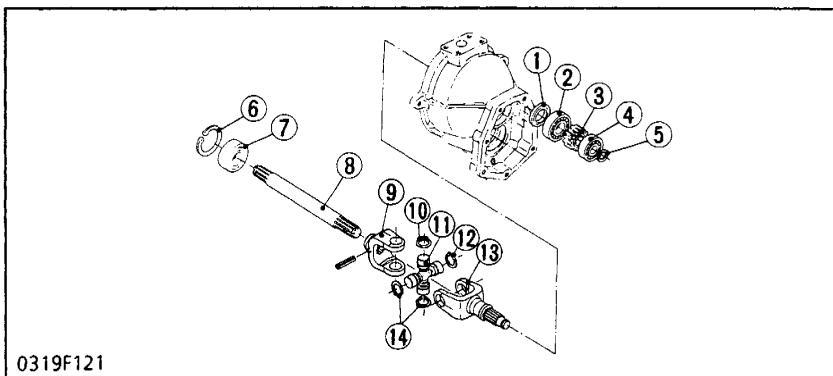

0319F121

- (1) Oil Seal
- (2) Bearing
- (3) 12T gear
- (4) Bearing
- (5) External Snap Ring
- (6) Internal Snap Ring
- (7) Oil Seal
- (8) Shaft
- (9) Joint
- (10) External Snap Ring
- (11) Universal Joint
- (12) External Snap Ring
- (13) Joint Shaft
- (14) External Snap Ring

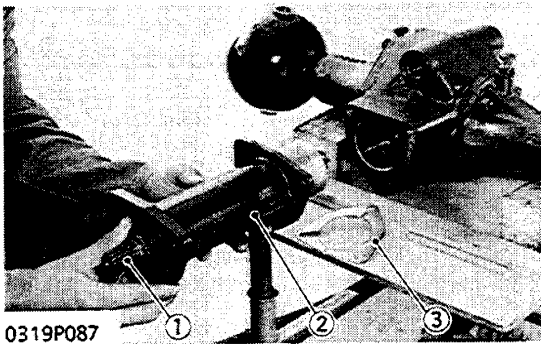

0319P087
 (1) Spiral Bevel Pinion Shaft
 (2) Spacer
 (3) Shim

Joint Case and Spacer

1. Remove the joint case.
2. Tap out the spring pin, and remove the joint assembly from the spiral bevel pinion shaft.
3. Remove the spacer mounting screw.
4. Remove the spacer (2) with the spiral bevel pinion shaft (1).

(When reassembling)

- Apply liquid gasket (Three Bond 1102 or equivalent) to both sides of a new gasket.
- Use care not to damage the O-ring on the spacer.
- Install the spacer to the front axle arm, noting the number of shims between them and the assembling direction of shim (3).

Tightening torque	Spacer mounting screw	18.6 to 32.3 N·m 1.9 to 3.3 kgf·m 13.7 to 23.9 ft·lbs N·m
-------------------	-----------------------	---

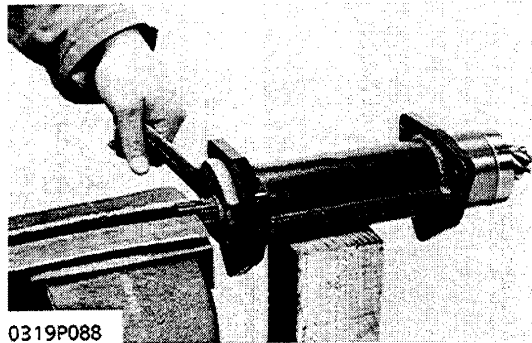

0319P088

Spiral Bevel Pinion Shaft

1. Secure the spiral bevel pinion shaft (1) in a vise.
2. Remove the stake of the staking nut and remove the staking nut (9).
3. Tap out the spiral bevel pinion shaft.

(When reassembling)

- Use care not to damage the oil seal (8).
- Replace the staking nut with a new one, and be sure to adjust the turning torque of spiral bevel pinion shaft. (Refer to page S.6-23)
- Stake the staking nut after performing adjustment, as shown in the figure.

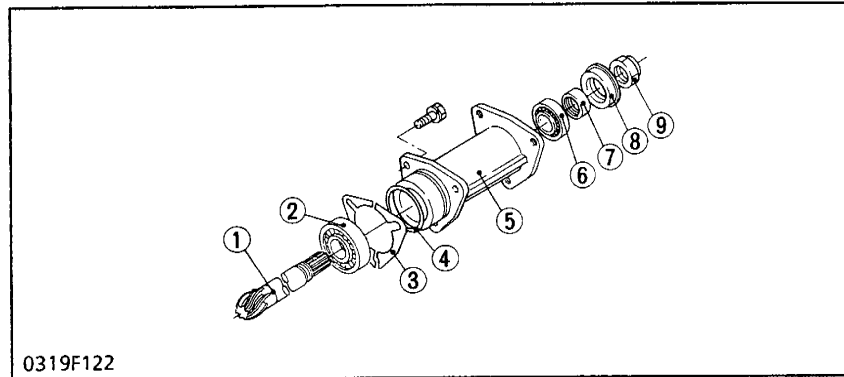

(1) Spiral Bevel Pinion Shaft
 (2) Taper Roller Bearing
 (3) Shim
 (4) O-ring
 (5) Spacer
 (6) Taper Roller Bearing
 (7) Bushing
 (8) Oil Seal
 (9) Staking Nut

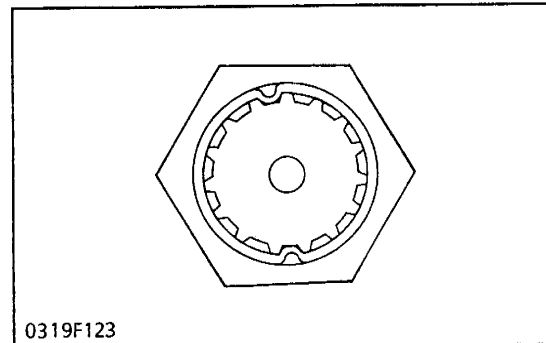

0319F123

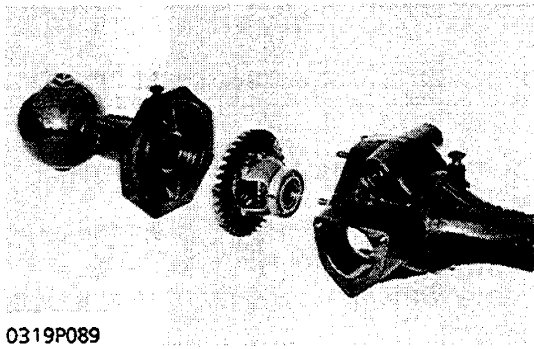

0319P089

Separation of Front Axle Case

1. Straight the lock plate (12), and remove the front axle case mounting nuts.
2. Separate the front axle case LH (1) from front axle case 1 (9).
3. Remove the differential.

(When reassembling)

- Apply liquid gasket (Three Bond 1102 or equivalent) to both sides of a new gasket.

Tightening torque	Front axle case mounting nut (M 8)	23.5 to 27.5 N·m 2.4 to 2.8 kgf·m 17.4 to 20.3 ft-lbs N·m
-------------------	------------------------------------	---

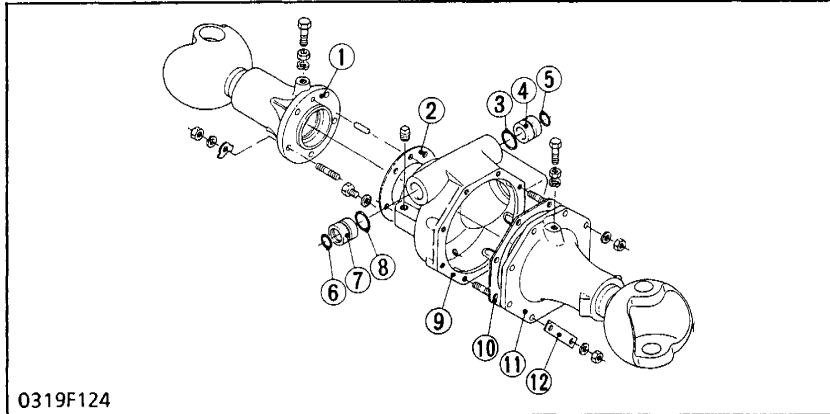

0319F124

- (1) Front Axle Case (RH)
- (2) Gasket
- (3) O-ring
- (4) Bushing
- (5) O-ring
- (6) O-ring
- (7) Bushing
- (8) O-ring
- (9) Front Axle Case 1
- (10) Gasket
- (11) Front Axle Case (LH)
- (12) Lock Plate

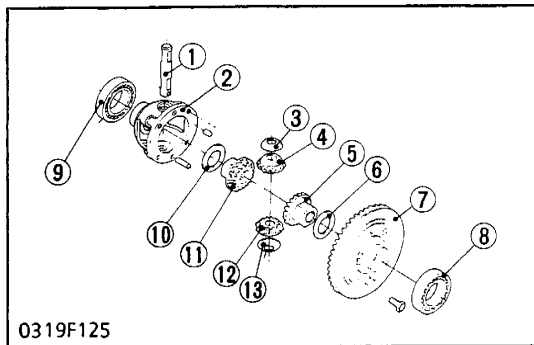

0319F125

Differential

1. For disassembling the differential, refer to [1] DIFFERENTIAL in REAR AXLE. (See page S.4-3)

- | | |
|--------------------------------|---------------------------------|
| (1) Differential Pinion Shaft | (8) Ball Bearing |
| (2) Differential Case | (9) Ball Bearing |
| (3) Differential Pinion Collar | (10) Shim |
| (4) Differential Pinion | (11) Differential Side Gear |
| (5) Differential Side Gear | (12) Differential Pinion Collar |
| (6) Shim | |
| (7) Ring Gear | |

SERVICING

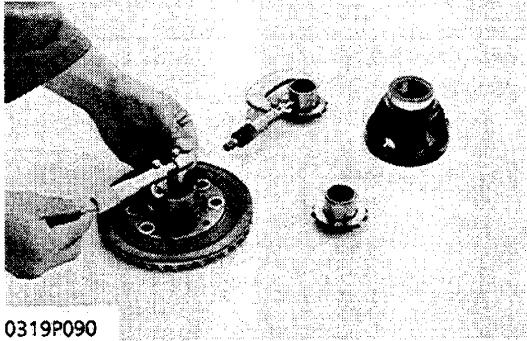

0319P090

Clearance between Differential Side Gear Boss and Differential

Case Bore

1. Measure the boss O.D. of the differential side gear with an outside micrometer.
2. Measure the bore I.D. of the differential case with an inside micrometer and calculate the clearance.
3. Measure the ring gear I.D. with an inside micrometer and calculate the clearance.
4. If the clearance exceeds the allowable limit, replace it.

Clearance between differential side gear boss and differential case bore	Factory spec.	0.040 to 0.074 mm 0.0016 to 0.0029 in.
	Allowable limit	0.30 mm 0.0118 in.
Differential side gear boss O.D.	Factory spec.	29.947 to 29.960 mm 1.1790 to 1.1795 in.
Differential case bore I.D.	Factory spec.	30.000 to 30.021 mm 1.1811 to 1.1819 in.
Ring gear I.D.	Factory spec.	30.000 to 30.021 mm 1.1811 to 1.1819 in.

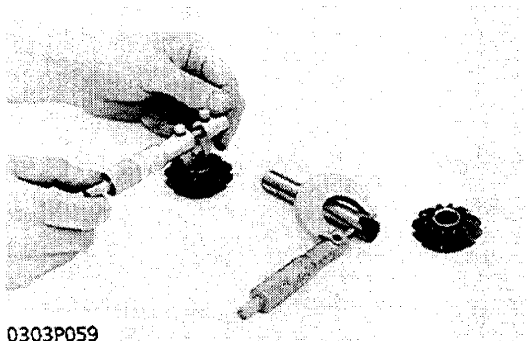

0303P059

Clearance between Differential Pinion Shaft and Differential

Pinion

1. Measure the pinion shaft O.D. of the differential side gear with an outside micrometer.
2. Measure the differential pinion I.D. with an inside micrometer and calculate the clearance.
3. If the clearance exceeds the allowable limit, replace.

Clearance between differential pinion shaft and differential pinion	Factory spec.	0.016 to 0.045 mm 0.0006 to 0.0018 in.
	Allowable limit	0.30 mm 0.0118 in.
Differential pinion shaft O.D.	Factory spec.	13.973 to 13.984 mm 0.5501 to 0.5506 in.
Differential pinion I.D.	Factory spec.	14.000 to 14.018 mm 0.5512 to 0.5519 in.

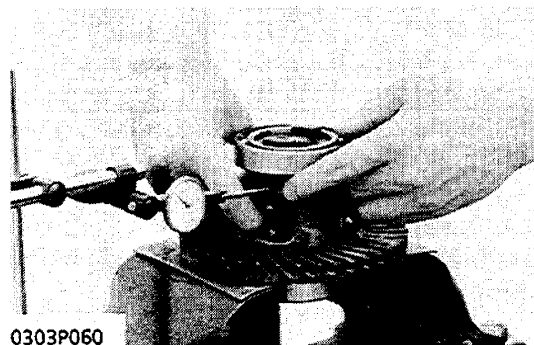

0303P060

Backlash between Differential Pinion and Differential

Side Gear

1. Secure the differential case in a vise.
2. Set a dial indicator (lever type) on the tooth of the differential side gear.
3. Hold the differential pinion and move the differential side gear to measure the backlash.
4. If the measurement exceeds the allowable limit, adjust with the differential side gear shim.

Backlash between differential pinion and differential side gear	Factory spec.	0.10 to 0.30 mm 0.0039 to 0.0118 in.
	Allowable limit	0.40 mm 0.0157 in.

(Reference)

- Thickness of shim: 1.0 mm (0.0394 in.)
1.2 mm (0.0472 in.)

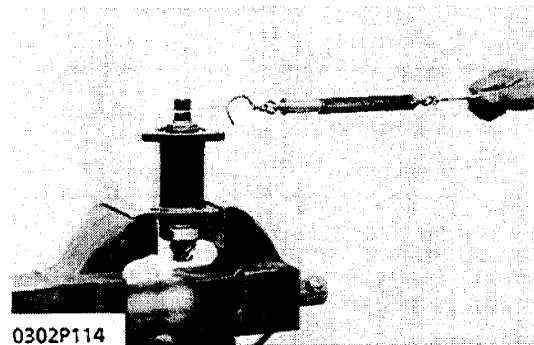

0302P114

Turning Torque of Spiral Bevel Pinion Shaft

1. Secure the spacer in a vise.
2. Wind a string around the spiral bevel pinion shaft and attach a spring balance to the tip of the string.
3. Slowly pull the spring balance in a direction at right angle to the spiral bevel pinion shaft to measure the turning torque.
4. If the turning torque is not within the factory specification, adjust with the staking nut.

Turning torque	Spiral bevel pinion shaft	1.27 to 1.67 N·m 0.13 to 0.17 kgf·m 0.94 to 1.23 ft-lbs
----------------	---------------------------	---

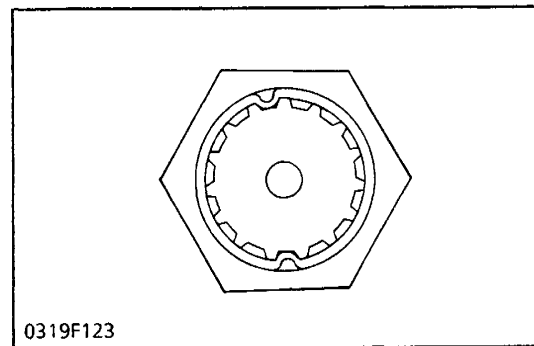

0319F123

NOTE

- The turning torque is figured by multiplying the radius of the spiral bevel pinion shaft by the reading on the spring balance.
- Stake the staking nut after performing adjustment, as shown in the figure.

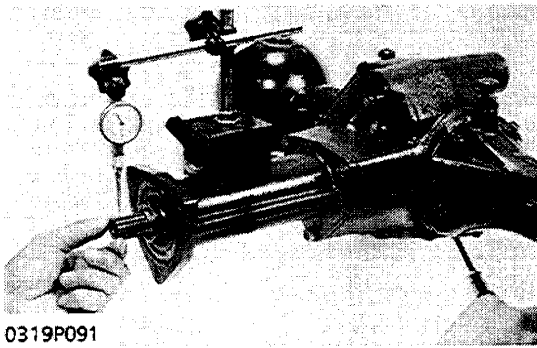

0319P091

Backlash between Ring Gear and Spiral Bevel Pinion Shaft

1. Insert a screwdriver through the drain plug hole in the front axle arm to hold the ring gear.
2. Set a dial indicator (lever type) on the spiral bevel pinion shaft.
3. Move the spiral bevel pinion shaft by hand and measure the circumferential play of the shaft.
4. Calculate the backlash from the ratio of the shaft diameter to the gear diameter.

Backlash = Measurement x 1.2

5. When the backlash is too small, decrease the number of shims in the side of the ring gear, and insert the removed shims in the opposite side. When the backlash is too large, decrease the number of shims in the side of the differential case, and insert the removed shims in the opposite side.
6. Adjust the backlash properly by repeating the above procedure.

Backlash between ring gear and spiral bevel pinion shaft	Factory spec.	0.10 to 0.20 mm 0.0039 to 0.0079 in.
	Allowable limit	0.40 mm 0.0157 in.

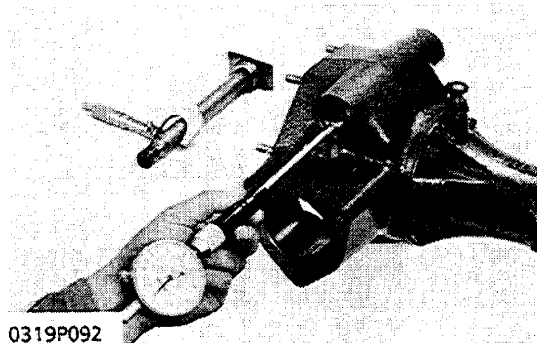

0319P092

Clearance between Center Pin and Bushing

1. Measure the center pin O.D. with an outside micrometer.
2. Measure the center pin bushing I.D. with a cylinder gauge and calculate the clearance.
3. If the clearance exceeds the allowable limit, replace it.

Clearance between center pin and bushing	Factory spec.	0.070 to 0.270 mm 0.0028 to 0.0106 in.
	Allowable limit	0.70 mm 0.0276 in.

Center pin O.D.	Factory spec.	19.88 to 20.03 mm 0.7827 to 0.7886 in.
Center pin bushing I.D.	Factory spec.	20.10 to 20.15 mm 0.7913 to 0.7933 in.

Toe-in, Front Wheel Steering Angle,

Refer to S.6-10

Camber Angle, Caster Angle, Kingpin Inclination, Sway of Front Wheel, Rocking Angle

Refer to S.6-10, 11, 12.

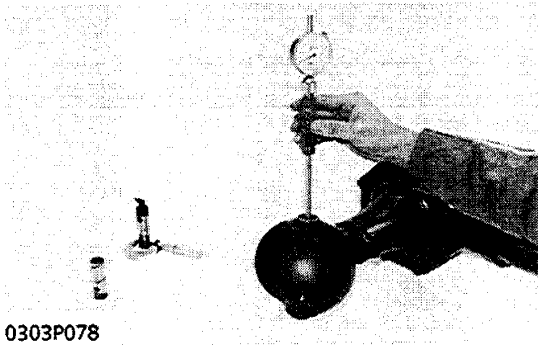

0303P078

Clearance between King Pin and King Pin Bushing

1. Measure the king pin O.D. with an outside micrometer.
2. Measure the king pin bushing I.D. with a cylinder gauge and calculate the clearance.
3. If the clearance exceeds the allowable limit, replace it.

Clearance between king pin and kingpin bushing	Factory spec.	0.02 to 0.07 mm 0.0008 to 0.0028 in.
	Allowable limit	0.50 mm 0.0197 in.
Kingpin O.D.	Factory spec.	19.98 to 20.00 mm 0.7866 to 0.7874 in.
Kingpin bushing I.D.	Factory spec.	20.02 to 20.05mm 0.7881 to 0.7894 in.

[B1750-B1750HST 4WD]

DISASSEMBLING AND ASSEMBLING

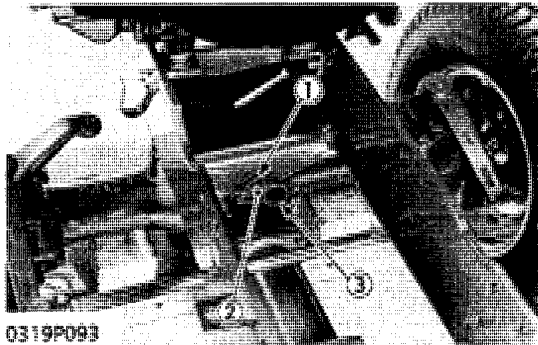

0319P093

- (1) Slotted nut
- (2) Center Pin

- (1) Set Spring

Separating Front Axle

1. Remove the set spring (3).
2. Remove the slotted nut (1), and pull out the center pin (2).
3. Separate the front axle from the front axle frame.

(When reassembling)

- Use care not to damage the O-ring.

NOTE

- Tighten the slotted nut to 9.8 N-m (1.0 kgf-m, 7.23 ft-lbs). If the slot and pin hole do not meet, loosen the nut until they do meet, and then install the set spring.
- When installing the set spring, insert it as shown in the figure.

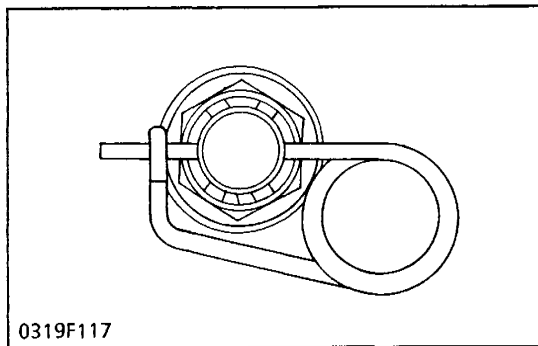

0319F117

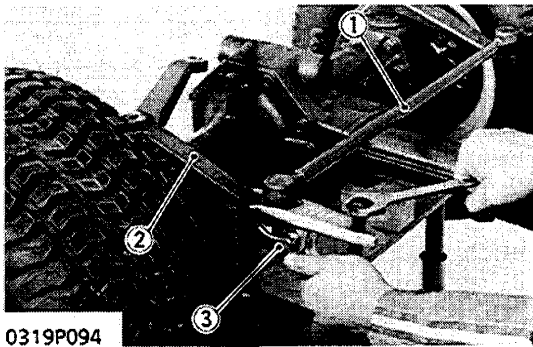

0319P094

- (1) Tie Rod
- (2) Knuckle Arm
- (3) Tie Rod End Lifter

Tie Rod

1. Pull out the cotter pin, and remove the slotted nut.
2. Remove the tie rod (1) from the knuckle arm (2) with the tie rod end lifter (3) (Code No: 07909-39021).
3. Remove the front wheel.

(When reassembling)

- Bend the cotter pin as shown in the figure.

Tightening torque	Slotted nut	17.7 to 34.3 N·m 1.8 to 3.5 kgf·m 13.0 to 25.3 ft·lbs
	Front wheel mounting nut	73.5 to 107.9 N·m 7.5 to 11.0 kgf·m 54.2 to 79.6 ft·lbs

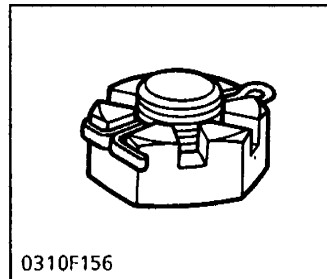

0310F156

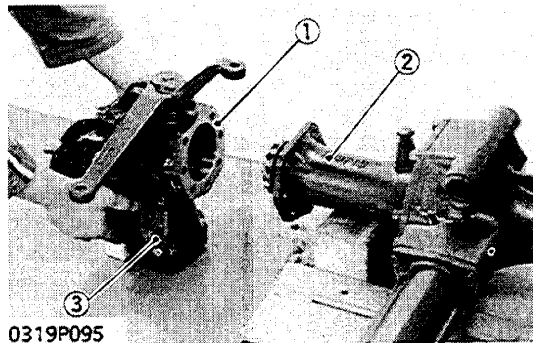

0319P095

- (1) Bevel Gear Case
- (2) Front Axle Arm
- (3) Front Axle Case

Separation of Front Axle Arm and Bevel Gear Case

1. Remove the bevel gear case (1) and front axle case (3) as a unit from the front axle arm (2).

(When reassembling)

- Install the bevel gear case to the front axle arm, noting the O-ring and the number of shims between them.

Tightening torque	Bevel gear case mounting screw	18.6 to 32.4 N·m 1.9 to 3.3 kgf·m 13.7 to 23.9 ft·lbs
-------------------	--------------------------------	---

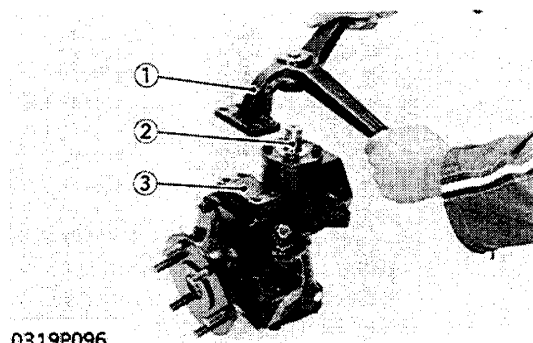

0319P096

- (1) Knuckle Arm
- (2) Knuckle Arm Support
- (3) Front Axle Case

Knuckle Arm and Knuckle Arm Support

1. Remove the knuckle arm (1)
2. Remove the knuckle arm support (2).

(When reassembling)

- Install the knuckle arm (1) to the front axle case (3), noting the O-ring and the number of shims between them.
- Be sure to replace the gasket on the bevel gear case with a new one.

■ IMPORTANT

- After reassembling be sure to adjust the clearance between the knuckle arm and knuckle arm support. (See page S.6-34)

Tightening torque	Knuckle arm mounting screw	39.2 to 64.7 N·m 4.0 to 6.6 kgf·m 28.9 to 47.7 ft·lbs
	Knuckle arm support mounting screw	18.6 to 32.4 N·m 1.9 to 3.3 kgf·m 13.7 to 23.9 ft·lbs

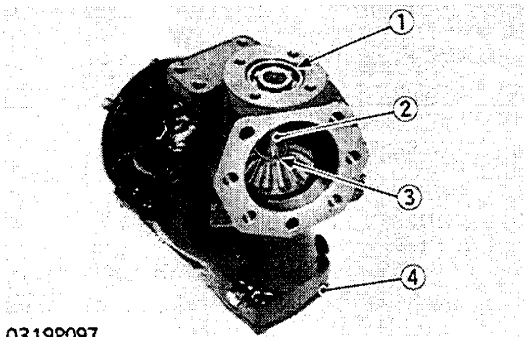

0319P097

- (1) Ball Bearing
- (2) Bevel Gear Shaft
- (3) External Snap Ring
- (4) Bevel Support Cover

Separation of Bevel Gear Case and Front Axle Case

1. Remove the bevel support cover (4).
2. Tap out the ball bearing (1) from the bevel gear case.
3. Remove the external snap ring (3).
4. Tap out the bevel gear shaft (2) downward, and separate the bevel gear case from the front axle case.

(When reassembling)

- Install the bevel support cover to the front axle case, noting O-ring and the number of shims between them.
- Use care not to damage the O-ring in the collar.

Tightening torque	Bevel support cover mounting screw	18.6 to 32.4 N·m 1.9 to 3.3 kgf·m 13.7 to 23.9 ft-lbs
-------------------	------------------------------------	---

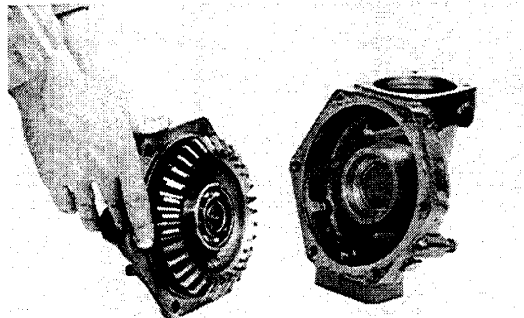

0302P106

Front Axle Cover

1. Remove the front axle cover mounting screws.
2. Separate the front axle cover from the front axle case.

(When reassembling)

- Install the front axle cover to the front axle case, noting the O-ring.

Tightening torque	Front axle cover mounting screw	44.1 to 63.7 N·m 4.5 to 6.5 kgf·m 32.5 to 47.0 ft-lbs
-------------------	---------------------------------	---

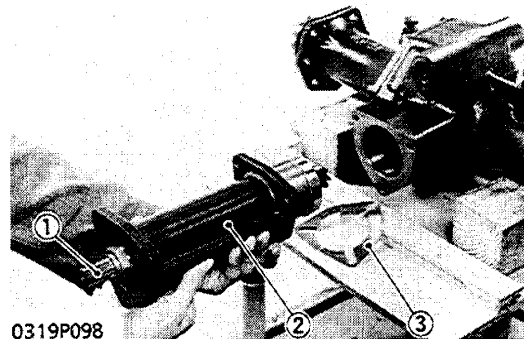

0319P098

- (1) Spiral Bevel Pinion Shaft
- (2) Spacer
- (3) Shim

Joint Case and Spacer

1. Remove the joint case.
2. Tap out the spring pin, and remove the joint assembly from the spiral bevel pinion shaft.
3. Remove the spacer mounting screw.
4. Remove the spacer (2) with the spiral bevel pinion shaft (1).

(When reassembling)

- Apply liquid gasket (Three Bond 1102 or equivalent) to both sides of a new gasket.
- Use care not to damage the O-ring on the spacer.
- Install the spacer to the front axle arm, noting the number of shims between them and the assembling direction of shim (3).

Tightening torque	Spacer mounting screw	18.6 to 32.4 N·m 1.9 to 3.3 kgf·m 13.7 to 23.9 ft-lbs
-------------------	-----------------------	---

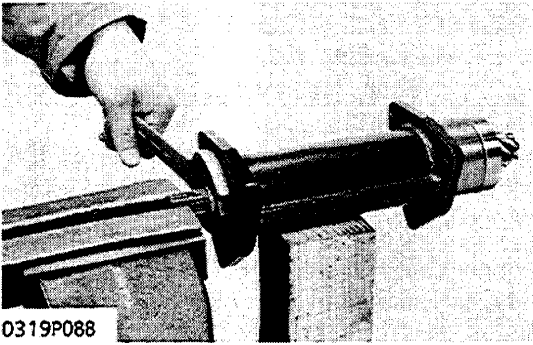

0319P088

Spiral Bevel Pinion Shaft

1. Secure the spiral bevel pinion shaft (1) in a vise.
2. Remove the stake of the staking nut and remove the staking nut (9).
3. Tap out the spiral bevel pinion shaft.

(When reassembling)

- Use care not to damage the oil seal (8).
- Replace the staking nut with a new one, and be sure to adjust the turning torque of spiral bevel pinion shaft. (See page S.6-31)
- Stake the taking nut after performing adjustment as shown in the figure.

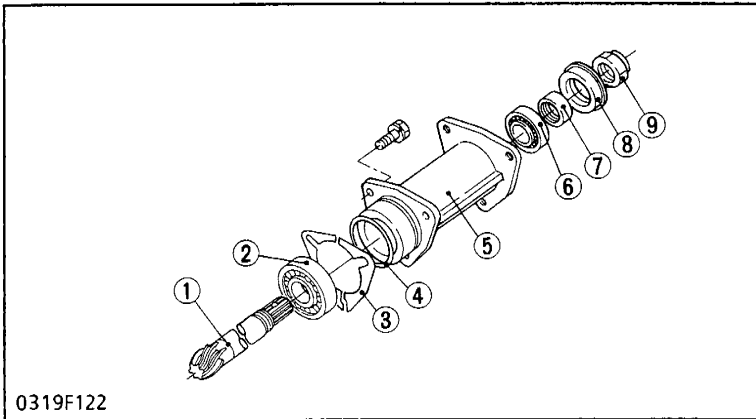

0319F122

- (1) Spiral Bevel Pinion Shaft
- (2) Taper Roller Bearing
- (3) Shim
- (4) O-ring
- (5) Spacer
- (6) Taper Roller Bearing
- (7) Bushing
- (8) Oil Seal
- (9) Staking Nut

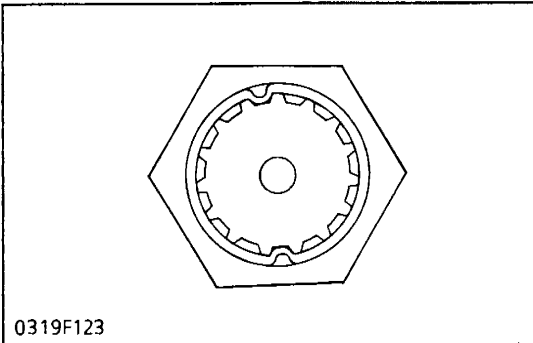

0319F123

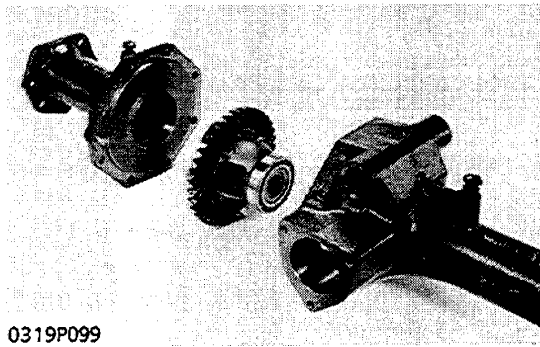

0319P099

Separation of Front Axle Arm

1. Remove the left and right differential gear shafts.
2. Remove the mounting screws and separate the front axle arm LH (7) and RH (5).
3. Remove the differential.

(When reassembling)

- Be sure to replace the gasket (6) on the front axle arm with a new one.

Tightening torque	Front axle arm mounting screw	44.1 to 63.7 N·m 4.5 to 6.5 kgf·m 32.5 to 47.0 ft-lbs
-------------------	-------------------------------	---

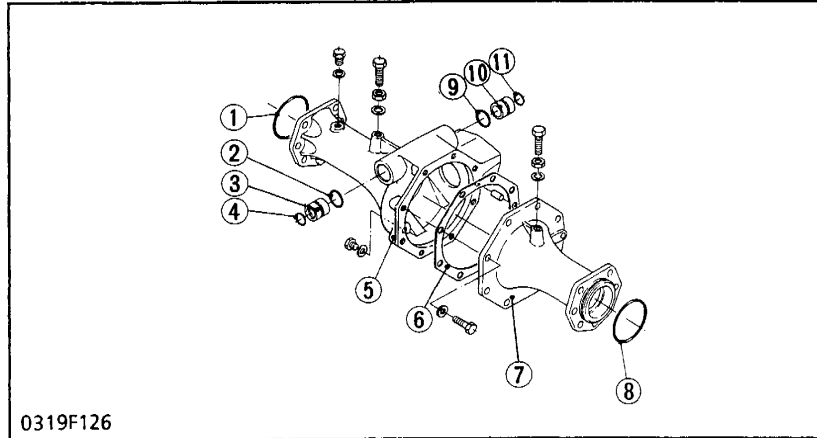

0319F126

- (1) O-ring
- (2) O-ring
- (3) Bushing
- (4) O-ring
- (5) Front Axle Arm (RH)
- (6) Gasket
- (7) Front Axle Arm (LH)
- (8) O-ring
- (9) O-ring
- (10) Bushing
- (11) O-ring

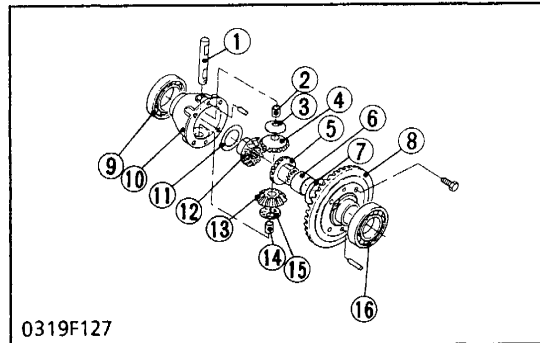

0319F127

Differential

1. For disassembling the differential, refer to [1] DIFFERENTIAL in REAR AXLE. (See page S.4-3.)

- (1) Differential Pinion Shaft
- (2) Bushing
- (3) Differential Pinion Collar
- (4) Differential Pinion
- (5) Differential Side Gear
- (6) Ring Gear Bushing
- (7) Shim
- (8) Ring Gear
- (9) Ball Bearing
- (10) Differential Case
- (11) Shim
- (12) Differential Side Gear
- (13) Differential Pinion
- (14) Bushing
- (15) Differential Pinion Collar
- (16) Ball Bearing

SERVICING

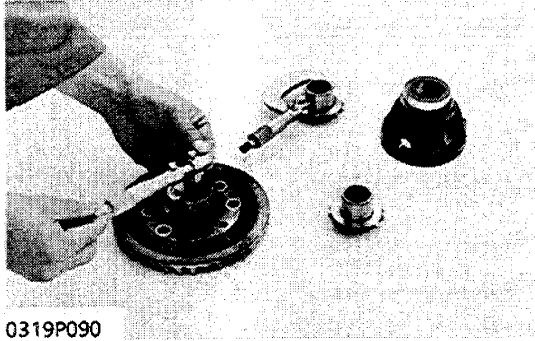

0319P090

Clearance between Differential Side Gear Boss and Differential Case Bore

1. Measure the boss O.D. of the differential side gear with an outside micrometer.
2. Measure the bore I.D. of the differential case with an inside micrometer and calculate the clearance.
3. Measure the bushing I.D. of the ring gear with an inside micrometer and calculate the clearance.
4. If the clearance exceeds the allowable limit, replace it.

Clearance between differential side gear boss and differential case bore	Factory spec.	0.025 to 0.066 mm 0.0010 to 0.0026 in.
	Allowable limit	0.30 mm 0.0118 in.
Differential side gear boss O.D.	Factory spec.	31.959 to 31.975 mm 1.2582 to 1.2589 in.
Differential case bore I.D.	Factory spec.	32.000 to 32.025 mm 1.2599 to 1.2608 in.
Ring gear bushing I.D.	Factory spec.	32.000 to 32.025 mm 1.2599 to 1.2608 in.

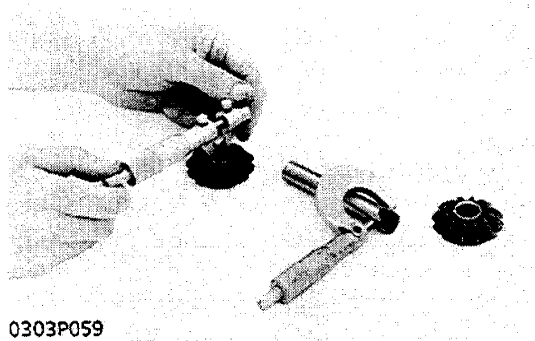

0303P059

Clearance between Differential Pinion Shaft and Differential Pinion Bushing

1. Measure the differential pinion shaft O.D. with an outside micrometer.
2. Measure the differential pinion bushing I.D. with an inside micrometer and calculate the clearance.
3. If the clearance exceeds the allowable limit, replace it.

Clearance between differential pinion shaft and differential pinion bushing	Factory spec.	0.02 to 0.05 mm 0.0008 to 0.0020 in.
	Allowable limit	0.25 mm 0.0098 in.
Differential pinion shaft O.D.	Factory spec.	13.97 to 13.98 mm 0.5500 to 0.5504 in.
Differential pinion bushing I.D.	Factory spec.	14.00 to 14.02 mm 0.5512 to 0.5520 in.

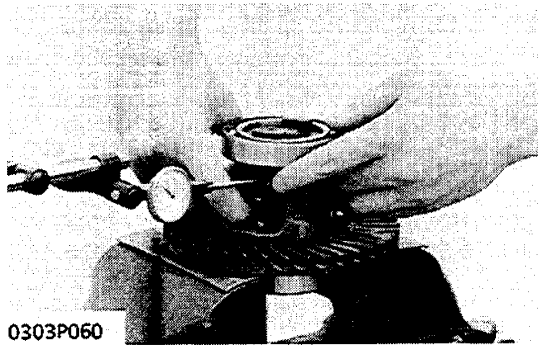

Backlash between Differential Pinion and Differential Side

Gear

1. Secure the differential case in a vise.
2. Set a dial indicator (lever type) on the tooth of the differential side gear.
3. Hold the differential pinion and move the differential side gear to measure the backlash.
4. If the measurement exceeds the allowable limit, adjust with the differential side gear shim.

Backlash between differential pinion and differential side gear	Factory spec.	0.10 to 0.30 mm 0.0039 to 0.0118 in.
	Allowable limit	0.40 mm 0.0157 in.

(Reference)

- Thickness of shims: 0.8 mm (0.0315 in.)
 1.0 mm (0.0384 in.)
 1.2 mm (0.0472 in.)

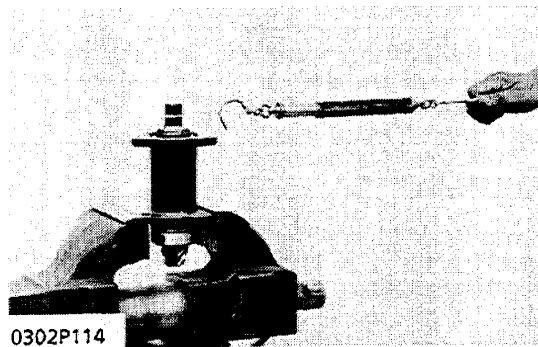

Turning Torque of Spiral Bevel Pinion Shaft

1. Secure the spacer in a vise.
2. Wind a string around the spiral bevel pinion shaft and attach a spring balance to the tip of the string.
3. Slowly pull the spring balance in a direction at right angle to the spiral bevel pinion shaft to measure the turning torque.
4. If the turning torque is not within the factory specifications, adjust with the staking nut.

Turning torque	Spiral bevel pinion shaft	1.27 to 1.67 N·m 0.13 to 0.17 kgf·m 0.94 to 1.23 ft-lbs
----------------	---------------------------	---

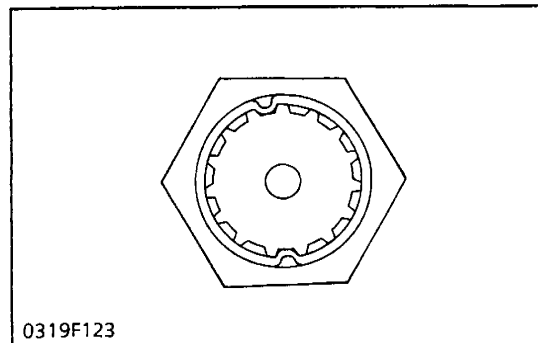

NOTE

- The turning torque is figured by multiplying the radius of the spiral bevel pinion shaft by the reading on the spring balance.
- Stake the staking nut after performing adjustment, as shown in the figure.

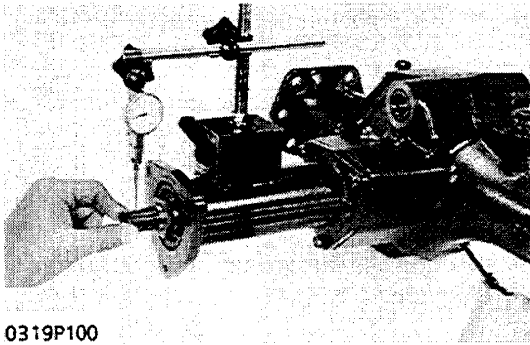

0319P100

Backlash between Ring Gear and Spiral Bevel Pinion Shaft

1. Insert a screwdriver through the drain plug hole in the front axle arm to hold the ring gear.
2. Set a dial indicator (lever type) on the spiral bevel pinion shaft.
3. Move the spiral bevel pinion shaft by hand and measure the circumferential play of the shaft.
4. Calculate the backlash from the ratio of the shaft diameter at the gear diameter.

$Backlash = Measurement \times 1.5$

5. When the backlash is too small, decrease the number of shims in the side of the ring gear, and insert the removed shims in the opposite side. When the backlash is too large, decrease the number of shims in the side of the differential case, and insert the removed shims in the opposite side.
6. Adjust the backlash properly by repeating the above procedure.

Backlash between ring gear and spiral bevel pinion shaft	Factory spec.	0.10 to 0.20 mm 0.0039 to 0.0079 in.
	Allowable limit	0.40 mm 0.0157 in.

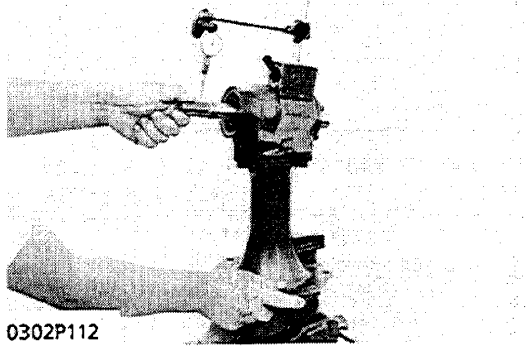

0302P112

Backlash of Bevel Gear in Bevel Gear Case

1. Set a dial indicator (lever type) on the bevel gear shaft.
2. Move the bevel gear shaft by hand and measure the circumferential play of the shaft.
3. Calculate the backlash from the ratio of the shaft diameter to the gear diameter.

$Backlash = Measurement \times 2.5$

4. If the backlash exceeds the allowable limit , adjust with shims between the front axle arm and bevel gear case.

Backlash of bevel gear in bevel gear case	Factory spec.	0.10 to 0.30 mm 0.0039 to 0.0118 in.
	Allowable limit	0.40 mm 0.0157 in.

■ NOTE

- The differential must be fixed during measurement.

(Reference)

- Thickness of shims: 0.2 mm (0.0079 in.)
 0.3 mm (0.0118 in.)
 0.5 mm (0.0197 in.)

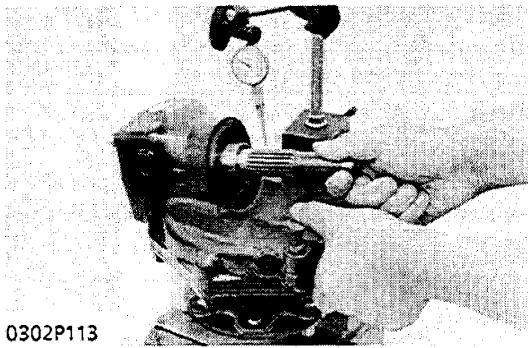

0302P113

Backlash of Bevel Gear in Front Axle Case

1. Secure the front wheel hub in a vise.
2. Set a dial indicator (lever type) on the bevel gear shaft.
3. Move the bevel gear shaft by hand and measure the circumferential play of the shaft.
4. Calculate the backlash from the ratio of the shaft diameter to the gear diameter.

$Backlash = Measurement \times 3.1$

5. If the backlash exceeds the allowable limit, adjust with shims between the bevel support cover and front axle case.

Backlash of bevel gear in front axle case	Factory spec.	0.10 to 0.20 mm 0.0039 to 0.0079 in.
	Allowable limit	0.40 mm 0.0157 in.

(Reference)

- Thickness of shims: 0.2 mm (0.0079 in.)
0.3 mm (0.0118 in.)
0.5 mm (0.0197 in.)

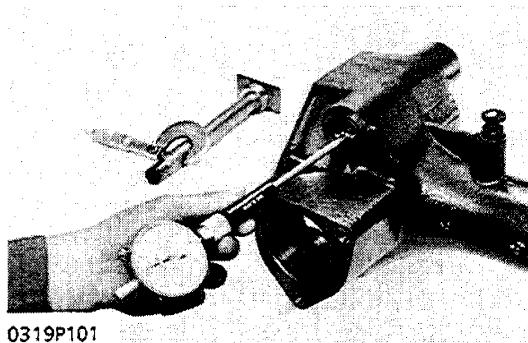

0319P101

Clearance between Center Pin and Bushing

1. Measure the center pin O.D. with an outside micrometer.
2. Measure the center pin bushing I.D. with a cylinder gauge and calculate the clearance.
3. If the clearance exceeds the allowable limit, replace it.

Clearance between center pin and bushing	Factory spec.	0.070 to 0.270 mm 0.0028 to 0.0106 in.
	Allowable limit	0.70 mm 0.0276 in.

Center pin O.D.	Factory spec.	19.88 to 20.03 mm 0.7827 to 0.7886 in.
-----------------	---------------	---

Center pin bushing I.D.	Factory spec.	20.10 to 20.15 mm 0.7913 to 0.7933 in.
-------------------------	---------------	---

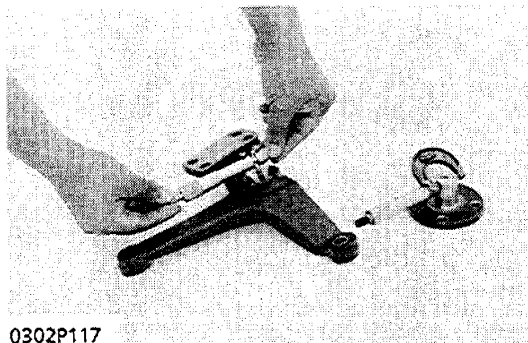

0302P117

Clearance between Knuckle Arm Support and Knuckle Arm Bushing

1. Measure the knuckle arm support O.D. with an outside micrometer.
2. Measure the knuckle arm bushing I.D. with an inside micrometer and calculate the clearance.
3. If the clearance exceeds the allowable limit, replace it.

Clearance between knuckle arm support and knuckle arm bushing	Factory spec.	0.022 to 0.110 mm 0.0009 to 0.0043 in.
	Allowable limit	0.40 mm 0.0157 in.

Knuckle arm support O.D.	Factory spec.	25.000 to 25.033 mm 0.9843 to 0.9855 in.
--------------------------	---------------	---

Knuckle arm bushing I.D.	Factory spec.	25.055 to 25.110 mm 0.9864 to 0.9886 in.
--------------------------	---------------	---

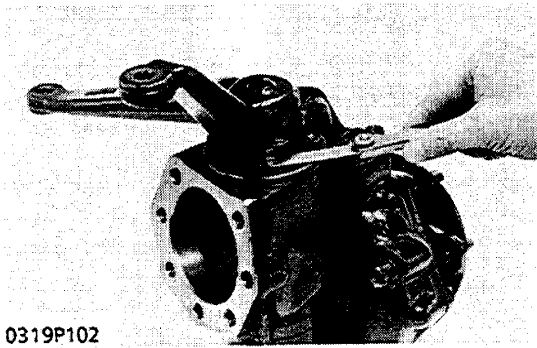

0319P102

Clearance between Knuckle Arm Support and Knuckle Arm

1. Tighten the knuckle arm to the specified torque (39.2 to 64.7 N-m, 4.0 to 6.6 kgf-m, 28.9 to 47.7 ft-lbs).
2. Measure the clearance between the knuckle arm support and knuckle arm with a feeler gauge.
3. If the measurement is not within the factory specifications, adjust with shims between the knuckle arm and front axle case.

Clearance between knuckle arm support and knuckle arm	Factory spec.	0 to 0.20 mm 0 to 0.0079 in.
---	---------------	---------------------------------

(Reference)

- Thickness of shims: 0.2 mm (0.0079 in.)
0.3 mm (0.0118 in.)
0.5 mm (0.0197 in.)

Toe-in, Front Wheel Steering Angle,

Refer to S.6-10.

Camber Angle, Caster Angle, Kingpin Inclination, Sway of**Front Wheel, Rocking Angle**

Refer to S.6-11, 12.

[B2150-B2150HST 4WD]

DISASSEMBLING AND ASSEMBLING

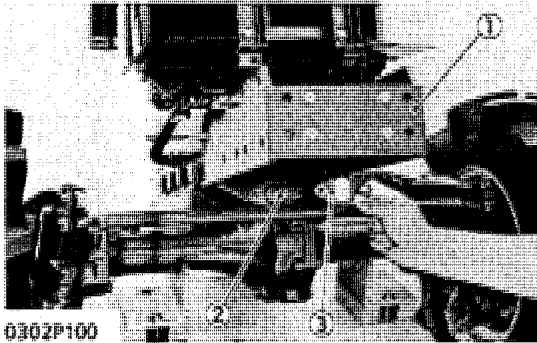

0302P100

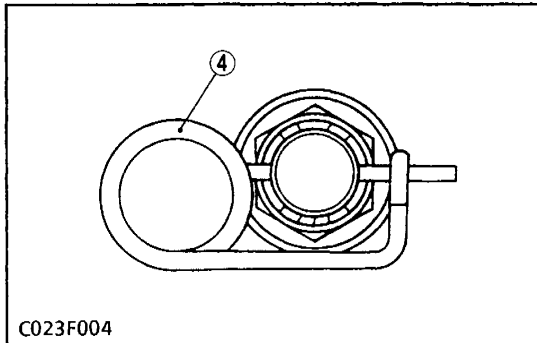

C023F004

- (1) Front Axle Frame
- (2) Center Pin
- (3) Lock Plate
- (4) Set Spring

Center Pin

1. Remove the set spring (4).
2. Remove the slotted nut.
3. Remove the lock plate (3), and pull out the center pin (2) forward.
4. Separate the front axle from the front axle frame (1).

(When reassembling)

Tightening torque	Slotted nut	9.8 N·m 1.0 kgf·m 7.23 ft-lbs
	Lock plate mounting nut	17.7 to 19.6 N·m 1.8 to 2.0 kgf·m 13.0 to 14.5 ft-lbs

■ NOTE

- Tighten the slotted nut to 9.8 N·m (1.0 kgf·m, 7.23 ft-lbs). If the slot and pin hole do not meet, loosen the nut until they do meet, and then install the set spring.
- When installing the set spring (4), insert it from the left side as shown in the figure.

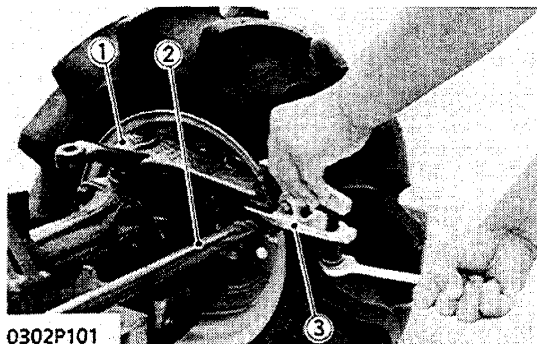

0302P101

- (1) Knuckle Arm
- (2) Tie Rod
- (3) Tie Rod End Lifter

Tie Rod

1. Pull out the cotter pin, and remove the slotted nut.
2. Remove the tie rod (2) from the knuckle arm (1) with the tie rod end lifter (3) (Code No : 07909-39021)
3. Remove the front wheels.

(When reassembling)

Tightening torque	Slotted nut for tie rod end	48.1 to 55.9 N·m 4.9 to 5.7 kgf·m 35.5 to 41.2 ft-lbs
	Front wheel mounting nut	77.4 to 90.2 N·m 7.9 to 9.2 kgf·m 57.2 to 66.5 ft-lbs

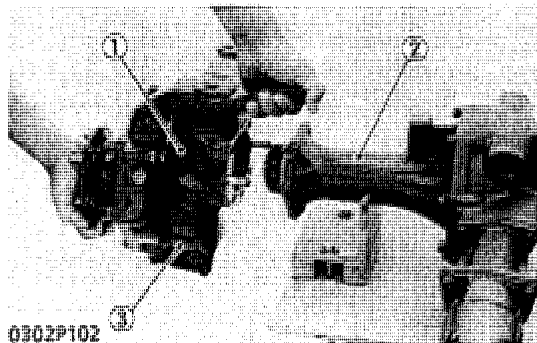

0302P102

- (1) Bevel Gear Case
- (2) Front Axle Arm
- (3) Front Axle Case

Separation of Front Axle Arm and Bevel Gear Case

1. Remove the bevel gear case (1) and front axle case (3) as a unit from the front axle arm (2).

(When reassembling)

- Install the bevel gear case to the front axle arm, noting the O-ring and the number of shims between them.

Tightening torque	Bevel gear case mounting screw and nut	77.4 to 90.2 N·m 7.9 to 9.2 kgf·m 57.2 to 66.5 ft-lbs
-------------------	--	---

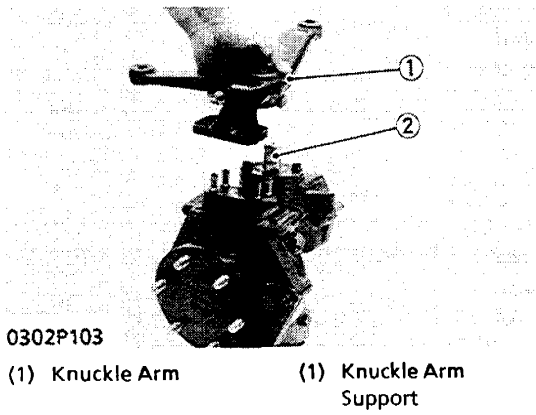

Knuckle Arm and Knuckle Arm Support

1. Remove the knuckle arm (1).
2. Remove the knuckle arm support (2).

(When reassembling)

- Install the knuckle arm to the front axle case, noting the number of shims between them.

Tightening torque	Knuckle arm mounting nut	48.1 to 55.9 N·m 4.9 to 5.7 kgf·m 35.5 to 41.2 ft-lbs
	Knuckle arm support mounting screw	23.5 to 27.5 N·m 2.4 to 2.8 kgf·m 17.4 to 20.2 ft-lbs

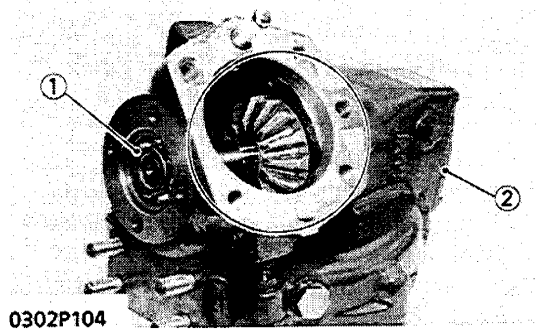

Separation of Bevel Gear Case and Front Axle Case

1. Remove the bevel support cover (2).
2. Tap out the ball bearing (1) from the bevel gear case.
3. Remove the external snap ring (3).
4. Tap out the bevel gear shaft downward, and separate the bevel gear case from the front axle case.

(When reassembling)

- Install the bevel support cover to front axle case, noting the O-ring and the number of shims between them.
- Use care not to damage the O-ring in the collar.

Tightening torque	Bevel support cover mounting screw	23.5 to 27.5 N·m 2.4 to 2.8 kgf·m 17.4 to 20.2 ft-lbs
-------------------	------------------------------------	---

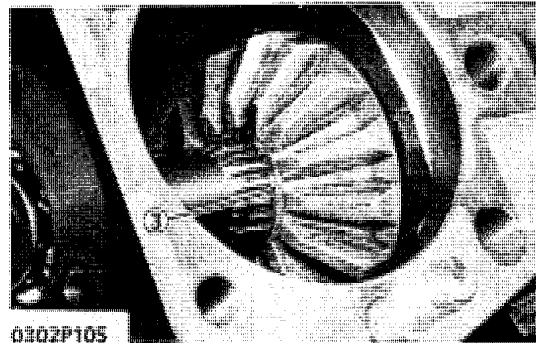

- (1) Ball Bearing (3) External Snap Ring
 (2) Bevel Support Cover

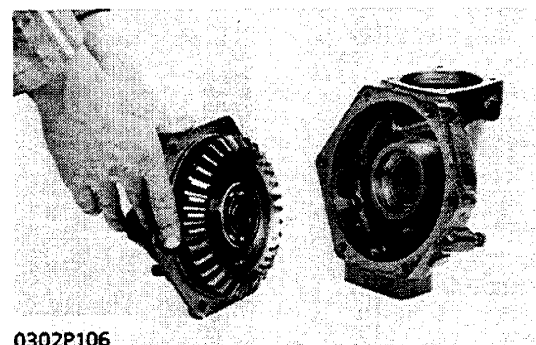

Front Axle Cover

1. Remove the front axle cover mounting screws.
2. Separate the front axle cover from the front axle case.

(When reassembling)

- Use care not to damage the O-ring at the front axle cover.

Tightening torque	Front axle cover mounting screw and nut	48.1 to 55.9 N·m 4.9 to 5.7 kgf·m 35.5 to 41.2 ft-lbs
-------------------	---	---

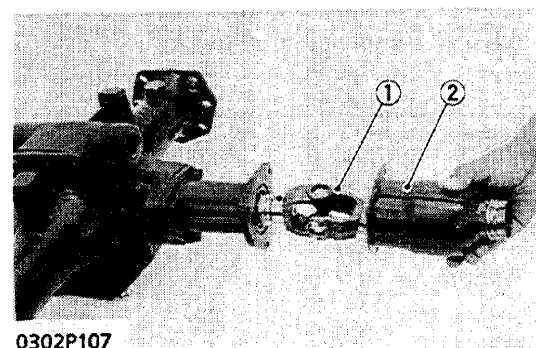

Joint Case

1. Remove the joint case (2).
2. Tap out the spring pin, and remove the joint assembly (1) from the front pinion shaft.

- (1) Joint Assembly (2) Joint Case

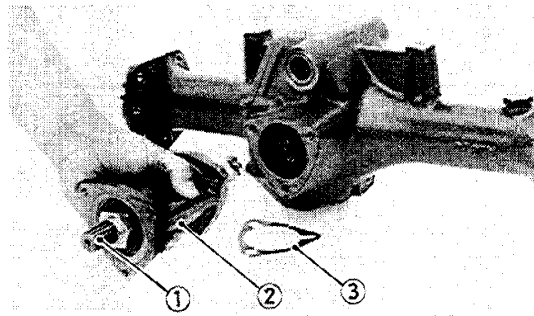

0302P108

- (1) Front Pinion Shaft
- (2) Spacer
- (3) Shim

Front Pinion Shaft

1. Remove the spacer mounting screw.
2. Remove the spacer (2) with the front pinion shaft (1).

(When reassembling)

- Install the spacer to the front axle arm, noting the assembling direction of shim (3).

Tightening torque	Spacer mounting screw	48.1 to 55.9 N·m 4.9 to 5.7 kgf·m 35.4 to 41.2 ft-lbs
-------------------	-----------------------	---

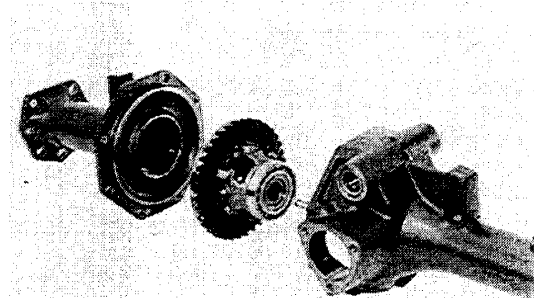

0302P109

Separation of Front Axle Arm

1. Remove the right and left differential gear shafts.
2. Remove the mounting screws and nuts and separate the front axle arm LH and RH.
3. Remove the differential assembly.

(When reassembling)

- Install the front axle arm LH to the front axle arm RH, using care not to damage the O-ring.

Tightening torque	Front axle arm mounting screw and nut	44.1 to 63.7 N·m 4.5 to 6.5 kgf·m 32.6 to 47.0 ft-lbs
-------------------	---------------------------------------	---

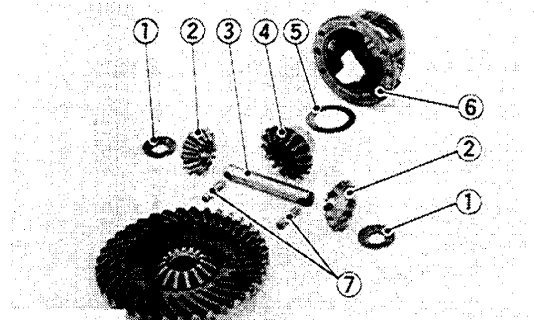

0302P110

- (1) Pinion Thrust Collar
- (2) Differential Pinion
- (3) Differential Pinion Shaft
- (4) Differential Side Gear
- (5) Shim
- (6) Differential Case
- (7) Dowel Pin

Differential

1. For disassembling the differential, refer to [1] DIFFERENTIAL in REAR AXLE section (Page S.4-3).

SERVICING

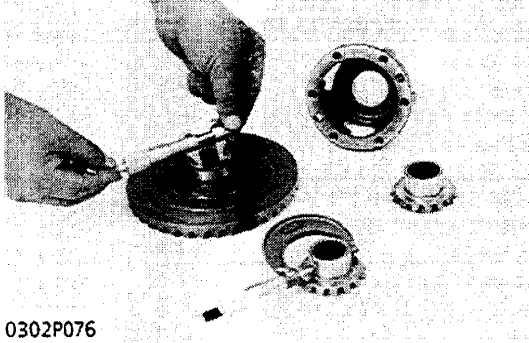

0302P076

Clearance between Differential Case and Differential Side

Gear

1. Measure the differential side gear boss O.D. with an outside micrometer.
2. Measure the differential case bore I.D. and 37T spiral bevel gear bushing I.D. with an inside micrometer.
3. If the clearance exceeds the allowable limit, replace it.

Clearance between differential case and differential side gear	Factory spec.	0.025 to 0.075 mm 0.0010 to 0.0029 in.
	Allowable limit	0.30 mm 0.0118 in.

Differential case I.D.	Factory spec.	37.000 to 37.025 mm 1.4567 to 1.4576 in.
Bushing I.D.	Factory spec.	37.000 to 37.025 mm 1.4567 to 1.4576 in.
Differential side gear O.D.	Factory spec.	36.950 to 36.975 mm 1.4547 to 1.4557 in.

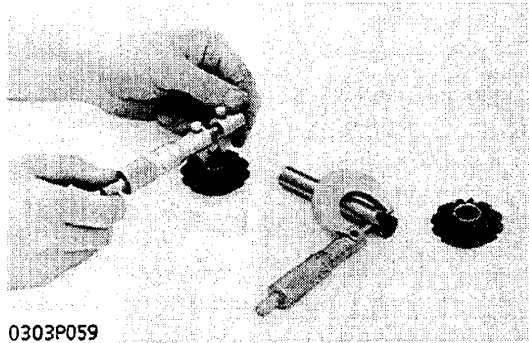

0303P059

Clearance between Differential Pinion Shaft and Differential

Pinion Bushing

1. Measure the differential pinion shaft O.D. with an outside micrometer.
2. Measure the differential pinion bushing I.D. with an inside micrometer.
3. If the clearance exceeds the allowable limit, replace it.

Clearance between differential pinion shaft and differential pinion bushing	Factory spec.	0.016 to 0.054 mm 0.0007 to 0.0021 in.
	Allowable limit	0.30 mm 0.0118 in.

Differential pinion shaft O.D.	Factory spec.	15.973 to 15.984 mm 0.6289 to 0.6293 in.
Differential pinion bushing I.D.	Factory spec.	16.000 to 16.027 mm 0.6300 to 0.6310 in.

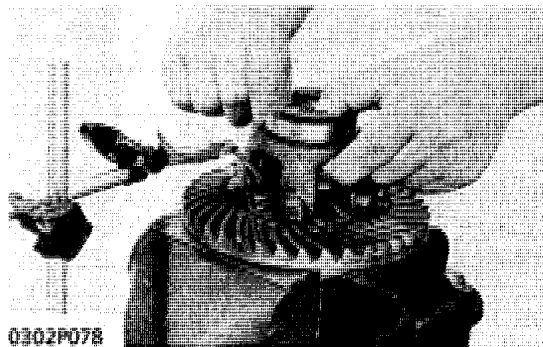

Backlash between Differential Pinion and Differential Side

Gear

1. Secure the differential case with a vise.
2. Press the differential pinion and differential side gear against the differential case.
3. Set the dial indicator (lever type) with its finger on the tooth of differential pinion.
4. Hold the differential side gear and move the differential pinion to measure backlash.
5. If the backlash exceeds the allowable limit, check shim of the differential side gear.

■ **NOTE**

- **Thickness of shims**
0.8 mm, 1.0 mm, 1.2 mm
(0.031 in. 0.039 in 0.047 in.)

Backlash between differential pinion and differential side gear	Factory spec.	0.02 to 0.20 mm 0.004 to 0.012 in.
	Allowable limit	0.40 mm 0.016 in.

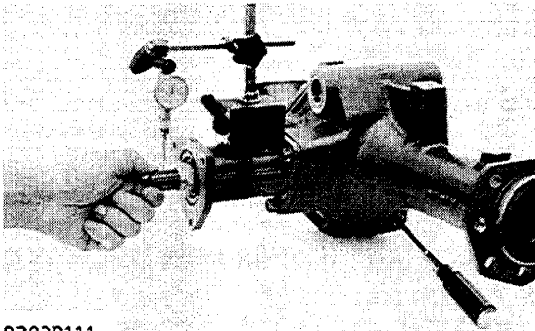

0302P111

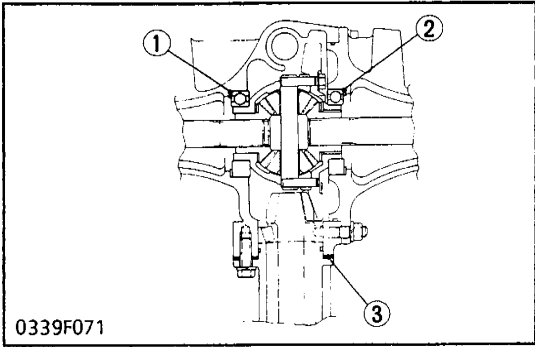

0339F071

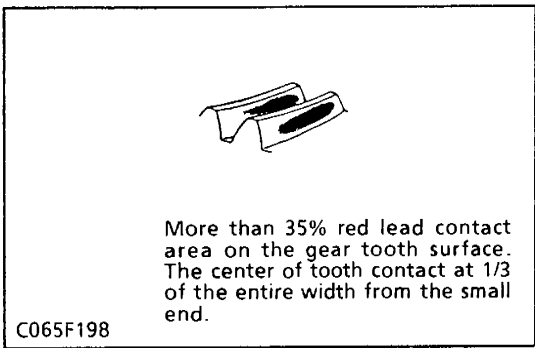

C065F198

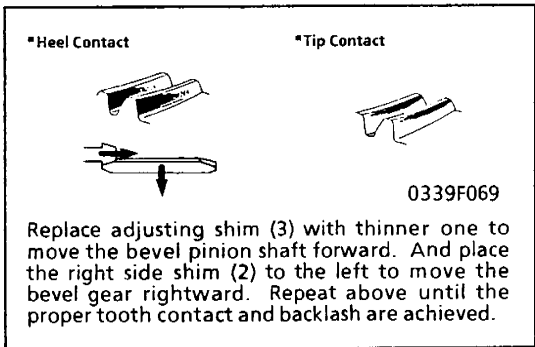

- (1) Shim
- (2) Shim
- (3) Shim

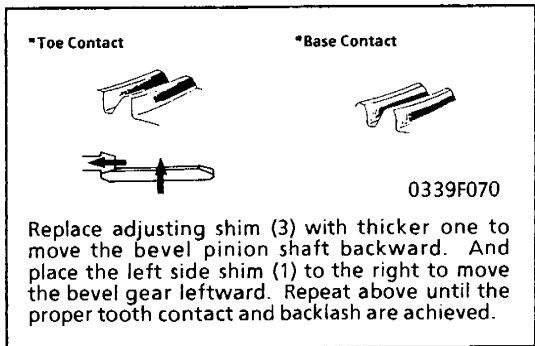

Backlash between Spiral Bevel Pinion and Spiral Bevel Gear

1. Insert a screwdriver through the drain plug hole in the front axle arm to hold the 37T spiral bevel gear.
2. Set the dial indicator (lever type) with its figure on the spiral bevel pinion shaft.
3. If the backlash exceeds the allowable limit, decrease the number of shim (1) at front axle arm LH and insert the removed shims to the front axle arm RH.
If the backlash is less than the factory specification, decrease the number of shims (2) at front axle arm RH and insert the removed shims to the front axle arm LH.
4. Adjust the backlash properly by repeating the above procedures.

Backlash between bevel gears in bevel gear case	Factory spec.	0.02 to 0.20 mm 0.0008 to 0.0079 in.
	Allowable limit	0.40 mm 0.016 in.

5. Apply red lead lightly over several teeth at three positions equally spaced on the bevel gear.
6. Turn the spiral bevel pinion shaft while pressing a wooden piece against the periphery of the bevel gear.
7. Check the tooth contact., If not proper, adjust with shims (1), (2) and (3) according to the instructions below.

(Reference)

- Thickness of adjusting shims (1), (2).
0.1 mm (0.004 in.), 0.2 mm (0.008 in.)
0.5 mm (0.020 in.)
- Thickness of adjusting shims (3)
0.2 mm (0.008 in.), 0.3 mm (0.012 in.)
0.5 mm (0.020 in.)

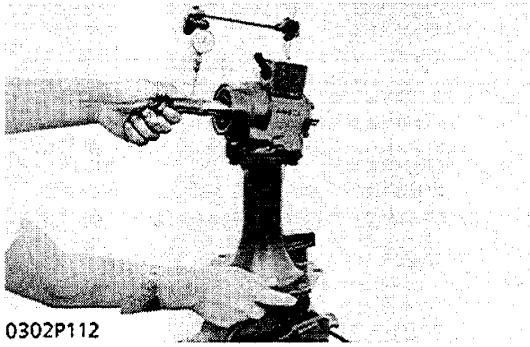

0302P112

Backlash between 13T Bevel Gear and 14T Bevel Gear

1. Set a dial indicator (lever type) on the bevel gear shaft.
2. Move the bevel gear shaft by hand and measure the circumferential play of the bevel gear shaft.
3. If the backlash exceeds the allowable limit, adjust with shims (1).

Backlash between 13T bevel gear and 14T bevel gear	Factory spec.	0.10 to 0.30 mm 0.0059 to 0.0118 in.
	Allowable limit	0.40 mm 0.016 in.

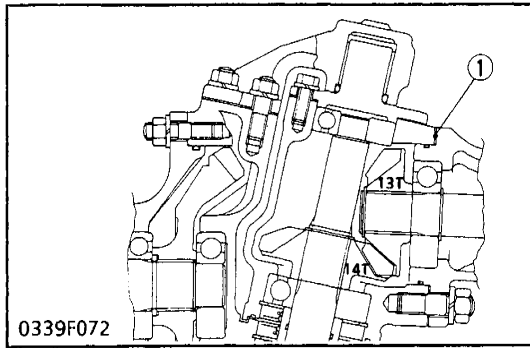

0339F072

(Reference)

- Thickness of adjusting shims (1).
0.2 mm (0.008 in.), 0.3 mm (0.012 in.)
0.5 mm (0.020 in.)

(1) Shim

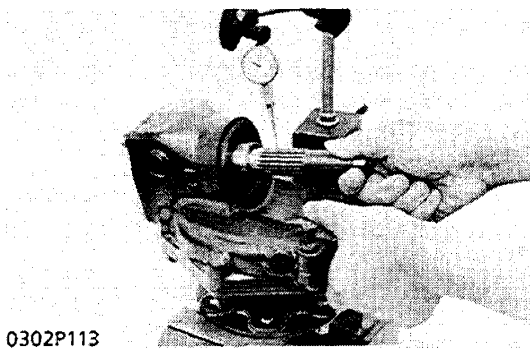

0302P113

Backlash between 17T Bevel Gear and 35T Bevel Gear

1. Secure the front wheel hub with a vise.
2. Set a dial indicator (lever type) on a spline tooth of the bevel gear shaft.
3. Move the bevel gear shaft and measure the backlash.
4. If the backlash exceeds the allowable limit, adjust with shims (1) between the bevel support cover and front axle case.

Backlash between 17T bevel gear and 35T bevel gear	Factory spec.	0.10 to 0.30 mm 0.0039 to 0.0118 in.
	Allowable limit	0.40 mm 0.016 in.

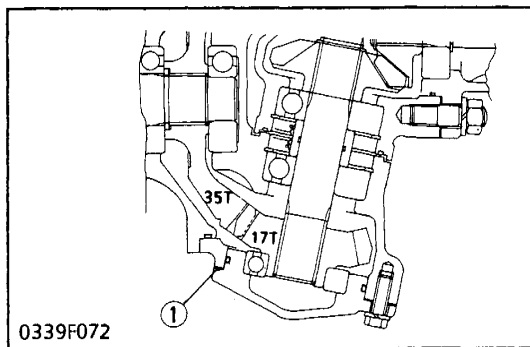

0339F072

(Reference)

- Thickness of adjusting shims (1).
0.2 mm (0.008 in.), 0.3 mm (0.012 in.)
0.5 mm (0.020 in.)

(1) Shim

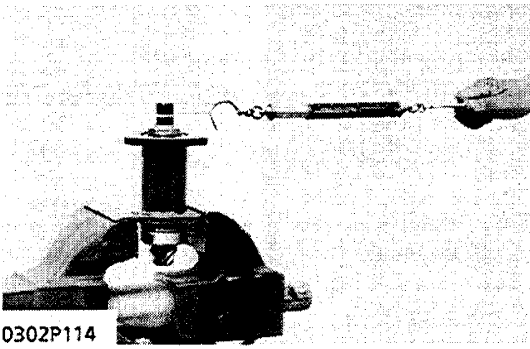

0302P114

Turning Torque of Bevel Pinion Shaft

1. Secure the spacer with a vise.
2. Wind a string around the bevel pinion shaft and attach spring balance to the tip of the string.
3. Slowly pull the spring balance in a direction at right angle to the bevel pinion shaft to measure the turning torque.
4. If the turning torque is not within the factory specifications, adjust with the nut (1).

Turning torque of bevel pinion shaft	Factory spec.	1.27 to 1.67 N·m 0.13 to 0.17 kgf·m 0.94 to 1.23 ft·lbs
--------------------------------------	---------------	---

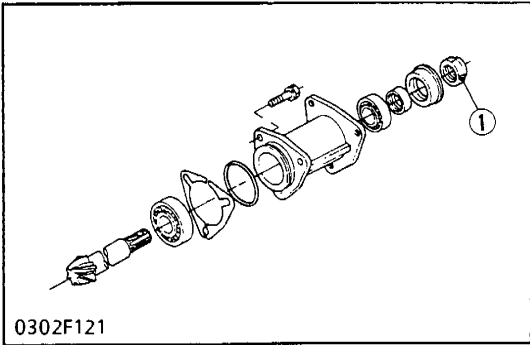

0302F121

NOTE

- The turning torque is figured by multiplying the radius (distance from the center of the bevel pinion shaft to a point on the circumference from which the string is pulled) by the reading on the spring balance.
- After turning torque adjustment, be sure to stake the nut (1).

(1) Staking Nut

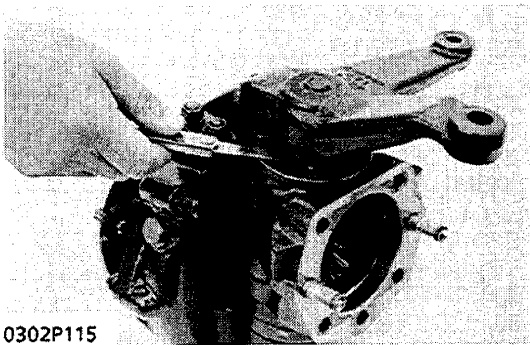

0302P115

Clearance between Knuckle Arm and Knuckle Arm Support

1. Tighten the knuckle arm to the specified torque (48.1 to 55.9 N·m, 4.9 to 5.7 kgf·m, 35.4 to 41.2 ft·lbs)
2. Measure the clearance between the knuckle arm and knuckle arm support with a feeler gauge.
3. If the clearance is not within the factory specifications, adjust with the shims (1) between the knuckle arm and front axle case.

Clearance between knuckle arm and knuckle arm support	Factory spec.	0 to 0.2 mm 0 to 0.008 in.
---	---------------	-------------------------------

NOTE

- Thickness of adjusting shims (1)
0.2 mm, 0.3 mm 0.5 mm
(0.008 in., 0.012in., 0.020 in.)

(1) Shim

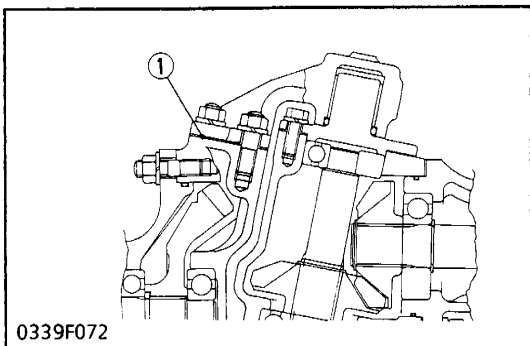

0339F072

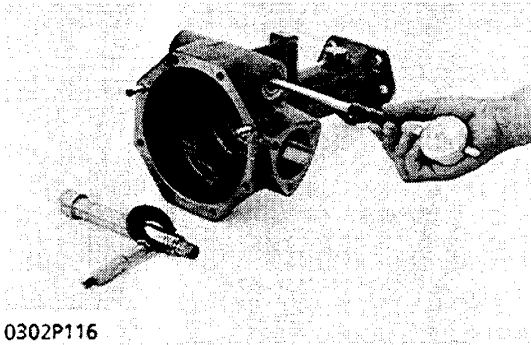

0302P116

Clearance between Center Pin and Bushing

1. Measure the center pin O.D. with an outside micrometer.
2. Measure the center pin bushing I.D. with a cylinder gauge.
3. If the clearance exceeds the allowable limit, replace.

Clearance between center pin and bushing	Factory spec.	0.100 to 0.202 mm 0.0040 to 0.0079 in.
	Allowable limit	0.70 mm 0.0276 in.
Center pin O.D.	Factory spec.	24.948 to 25.000 mm 0.9822 to 0.9842 in.
Center pin bushing I.D.	Factory spec.	25.100 to 25.150 mm 0.9882 to 0.9901 in.

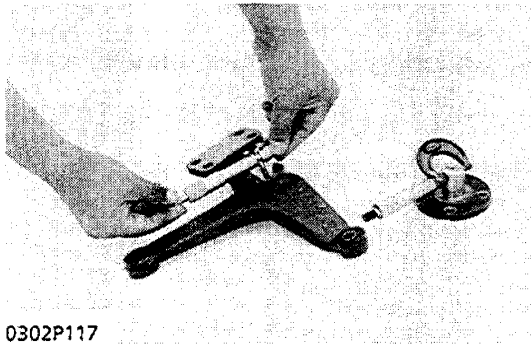

0302P117

Clearance between Knuckle Arm Support and Knuckle Arm Bushing

1. Measure the knuckle arm support O.D. with an outside micrometer.
2. Measure the knuckle arm bushing I.D. with an inside micrometer.
3. If the clearance exceeds the allowable limit, replace it.

Clearance between knuckle arm support and knuckle arm bushing	Factory spec.	0.022 to 0.110 mm 0.0009 to 0.0043 in.
	Allowable limit	0.40 mm 0.0157 in.
Knuckle arm support O.D.	Factory spec.	25.000 to 25.033 mm 0.9843 to 0.9855 in.
Knuckle arm bushing I.D.	Factory spec.	25.055 to 25.110 mm 0.9864 to 0.9886 in.

Toe-in, Front Wheel Steering Angle

Refer to S.6-10.

Camber Angle, Caster Angle, Kingpin Inclination

Sway of Front Wheel

Refer to S.6-11.12.

[B1550-B1750-B1550HST-B1750HST BI-SPEED TURN]

DISASSEMBLING AND ASSEMBLING

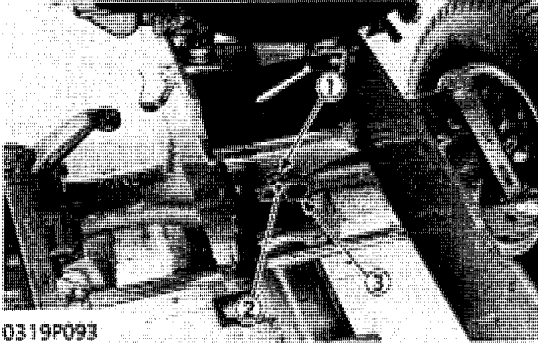

0319P093

- (1) Slotted Nut
- (2) Center Pin
- (3) Set Spring

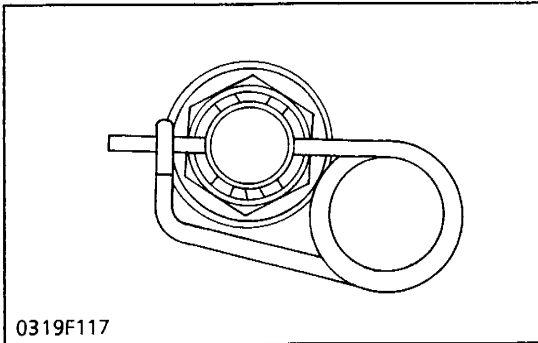

0319F117

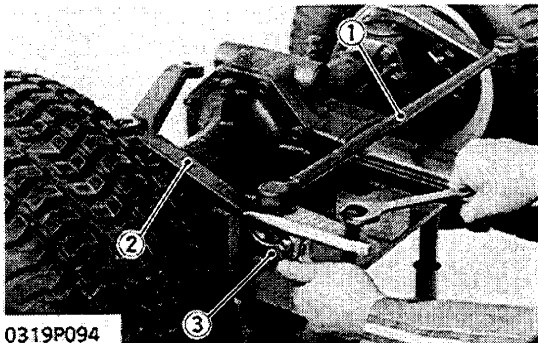

0319P094

- (1) Tie Rod
- (2) Knuckle Arm
- (3) Tie Rod End Lifter

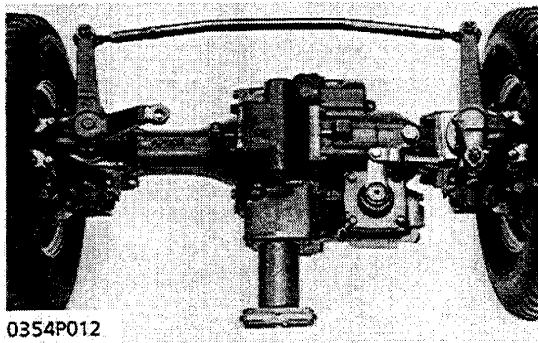

0354P012

Separating Front Axle

1. Remove the set spring (3).
2. Remove the slotted nut (1), and pull out the center pin (2).
3. Separate the front axle from the front axle frame.

(When reassembling)

- Use care not to damage the O-ring.

■ NOTE

- Tighten the slotted nut to 9.8 N-m (1.0 kgf-m, 7.23 ft-lbs). If the slot and pin hole do not meet, loosen the nut until they do meet, and then install the set spring.
- When installing the set spring, insert it as shown in the figure.

■ NOTE

- Figures and photographs are based on B1750 in this section.

Tie Rod

1. Pull out the cotter pin, and remove the slotted nut.
2. Remove the tie rod (1) from the knuckle arm (2) with the tie rod end lifter (3) (Code No; 07909-39021).
3. Remove the front wheel.

(When reassembling)

- Bend the cotter pin as shown in the figure.

Tightening torque	Slotted nut	17.7 to 34.3 N-m 1.8 to 3.5 kgf-m 13.0 to 25.3 ft-lbs
	Front wheel mounting nut	73.5 to 107.9 N-m 7.5 to 11.0 kgf-m 54.2 to 79.6 ft-lbs

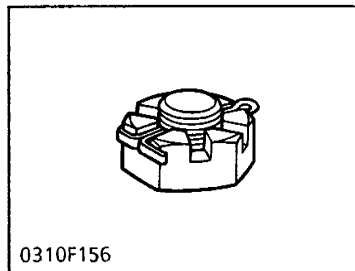

0310F156

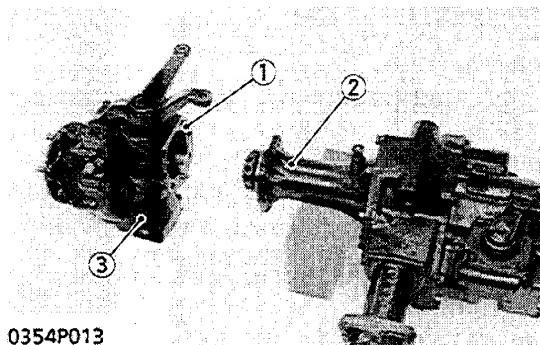

0354P013

- (1) Bevel Gear Case
- (2) Front Axle Arm
- (3) Front Axle Case

Separation of Front Axle Arm and Bevel Gear Case

1. Remove the bevel gear case (1) and front axle case (3) as a unit from the front axle arm (2).

(When reassembling)

- Install the bevel gear case to the front axle arm, noting the O-ring and the number of shims between them.

Tightening torque	Bevel gear case mounting screw	18.6 to 32.4 N·m 1.9 to 3.3 kgf·m 13.7 to 23.9 ft-lbs
-------------------	--------------------------------	---

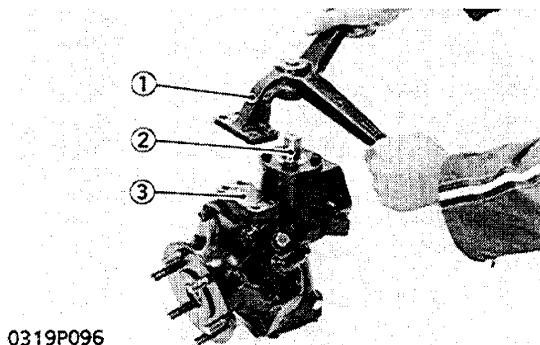

0319P096

- (1) Knuckle Arm
- (2) Knuckle Arm Support
- (3) Front Axle Case

Knuckle Arm and Knuckle Arm Support

1. Remove the knuckle arm (1).
2. Remove the Knuckle arm support (2).

(When reassembling)

- Install the knuckle arm (1) to the front axle case (3), noting the O-ring and the number of shims between them.
- Be sure to replace the gasket on the bevel gear case with a new one.

■ IMPORTANT

- After reassembling, be sure to adjust the clearance between the knuckle arm and knuckle arm support. (See page S.6-34)

Tightening torque	Knuckle arm mounting screw	39.2 to 64.7 N·m 4.0 to 6.6 kgf·m 28.9 to 47.7 ft-lbs
	Knuckle arm support mounting screw	18.6 to 32.4 N·m 1.9 to 3.3 kgf·m 13.7 to 23.9 ft-lbs

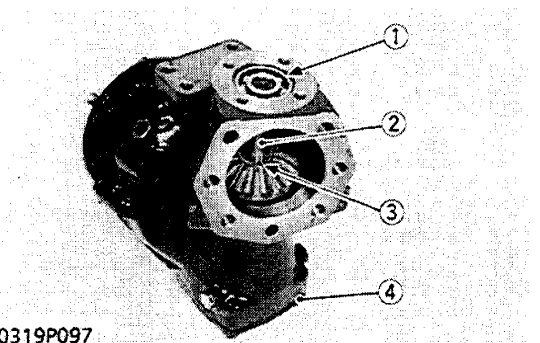

0319P097

- (1) Ball Bearing
- (2) Bevel Gear Shaft
- (3) External Snap Ring
- (4) Bevel Support Cover

Separation of Bevel Gear Case and Front Axle Case

1. Remove the bevel support cover (4).
2. Tap out the ball bearing (1) from the bevel gear case.
3. Remove the external snap ring (3).
4. Tap out the bevel gear case from the front axle case.

(When reassembling)

- Install the bevel support cover to the front case, noting the O-ring and the number of shims between them.
- Use care not damage the O-ring in the collar.

Tightening torque	Bevel support cover mounting screw	18.6 to 32.4 N·m 1.9 to 3.3 kgf·m 13.7 to 23.9 ft-lbs
-------------------	------------------------------------	---

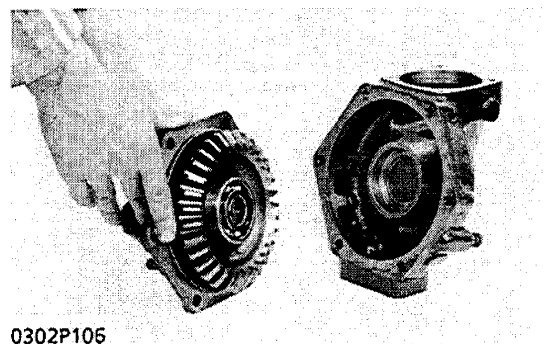

0302P106

Front Axle Cover

1. Remove the front axle cover mounting screws.
2. Separate the front axle cover from the front axle case.

(When reassembling)

- Install the front axle cover to the front axle case, noting the O-ring.

Tightening torque	front axle cover mounting screw	44.1 to 63.7 N·m 4.5 to 6.5 kgf·m 32.5 to 47.0 ft-lbs
-------------------	---------------------------------	---

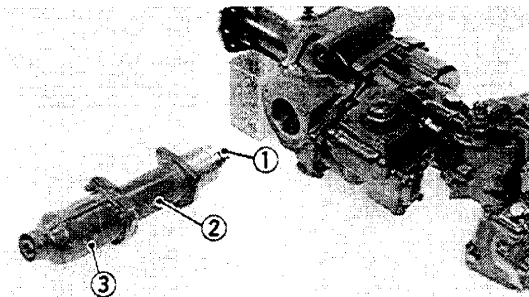

0354P014

- (1) Spiral Bevel Pinion Shaft
- (2) Spacer
- (3) Joint Case

Joint Case and Spacer

1. Remove the joint case (3).
2. Tap out the spring pin, and remove the joint assembly from the spiral bevel pinion shaft.
3. Remove the spacer mounting screw.
4. Remove the spacer (2) with the spiral bevel pinion shaft (1).

(When reassembling)

- Apply liquid gasket (Three Bond 1102 or equivalent) to both sides of a new gasket.
- Use care not to damage the O-ring on the spacer.

Tightening torque	Spacer mounting screw	18.6 to 32.4 N·m 1.9 to 3.3 kgf·m 13.7 to 23.9 ft-lbs
-------------------	-----------------------	---

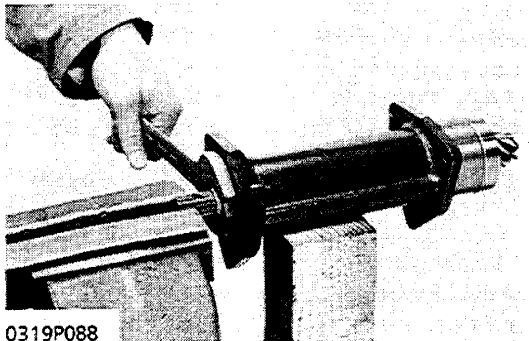

0319P088

Spiral Bevel Pinion Shaft

1. Secure the spiral bevel pinion shaft (1) in a vise.
2. Remove the stake of the staking nut and remove the staking nut (8).
3. Tap out the spiral bevel pinion shaft.

(When reassembling)

- Use care not to damage the oil seal (7).
- Replace the staking nut with a new one, and be sure to adjust the turning torque of spiral bevel pinion shaft. (See page 5.6-50)
- Stake the staking nut after performing adjustment as shown in the figure.

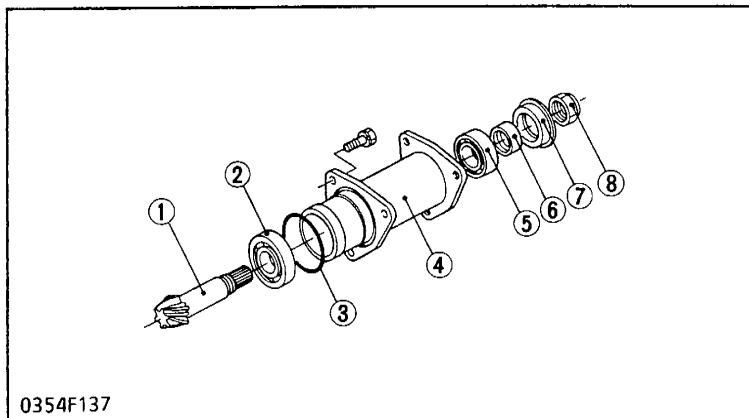

0354F137

- (1) Spiral bevel Pinion Shaft
- (2) Taper Roller Bearing
- (3) O-ring
- (4) Spacer
- (5) Taper Roller Bearing
- (6) Bushing
- (7) Oil Seal
- (8) Staking Nut

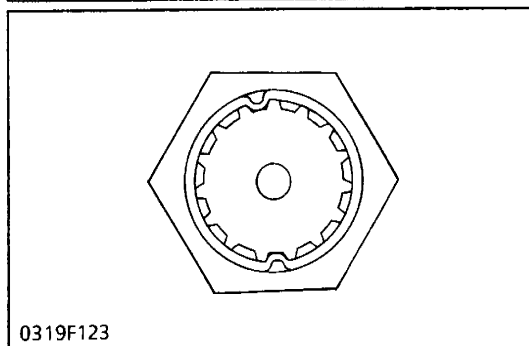

0319F123

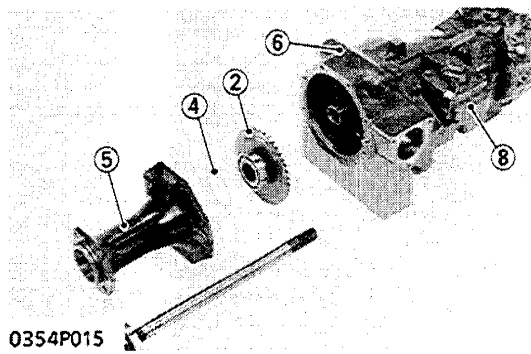

0354P015

Separation of Front Axle Arm

1. Remove the left differential gear shafts.
2. Remove the mounting screws and separate the front axle arm LH (5) and front axle case LH (6).
3. Remove the bevel ring gear.

(When reassembling)

- Be sure to replace the gasket (7) on the front axle arm with a new one.
- Install the front axle arm LH (5) and front axle case LH (6), adjusting the backlash with shims between the bevel gear and the bevel pinion shaft. (Refer to S.6-24, 32.)

Tightening torque	Front axle arm mounting screw	44.1 to 63.7 N·m 4.5 to 6.5 kgf·m 32.5 to 47.0 ft·lbs
-------------------	-------------------------------	---

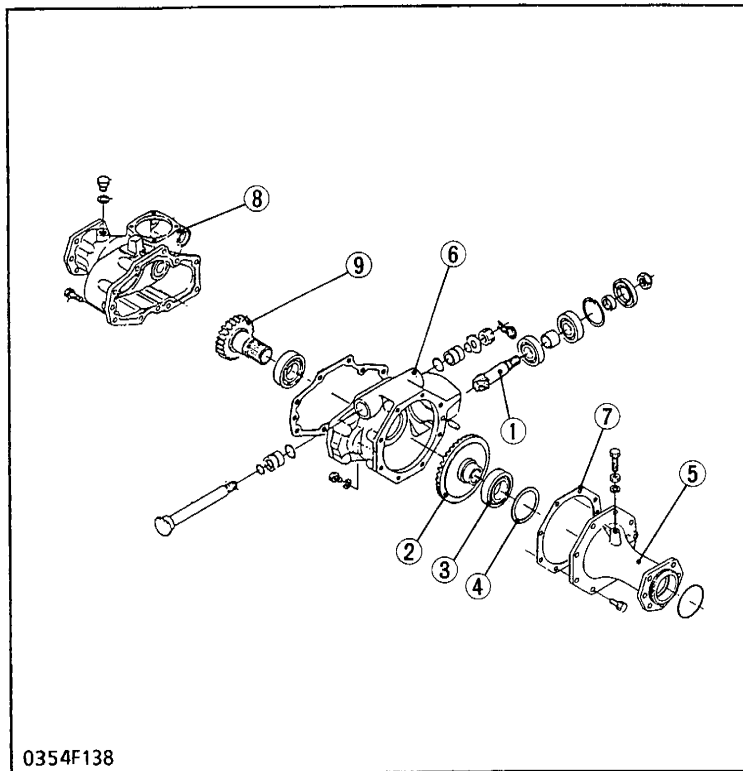

0354F138

- (1) Front Pinion
- (2) Bevel Ring Gear
- (3) Ball Bearing
- (4) Shims
- (5) Front Axle Arm (LH)
- (6) Front Axle Case (LH)
- (7) Gasket
- (8) Front Axle Case (RH)
- (9) Gear Shaft

Thickness of shims: 0.5, 0.3, 0.2 mm
(0.0197, 0.0118, 0.0079 in.)

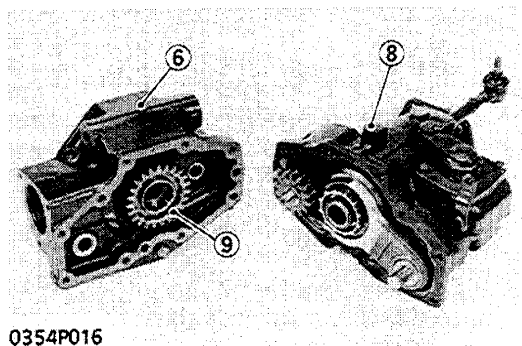

0354P016

Separation of Front Axle Case

1. Remove the mounting screws and separate the front axle cases (6), (8) each other.

(When reassembling)

- Be sure to set the collar inside of the gear-shaft (9).

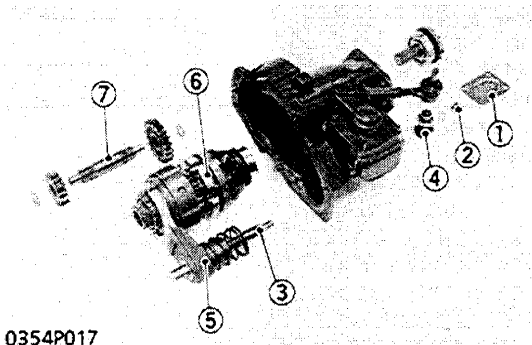

0354P017

Front Axle Case

1. Remove the case cover (1) and nut (2), and the shift rod (3).
2. Remove the front differential assembly (6), shift fork assembly (5) and bi-speed turn shaft assembly (7) together from the front axle case.
3. Separate the shift fork assembly (5) from the front differential gear assembly.

- | | |
|------------------------|----------------------------------|
| (1) Case Cover | (5) Shift Fork Assembly |
| (2) Nut | (6) Front Differential Assembly |
| (3) Shift Rod | (7) Bi-speed Turn Shaft Assembly |
| (4) Shift Roller Shaft | (8) Mark |

(When reassembling)

- After setting the spring pin on the shift rod (3), install it in the case. Tighten the nut (2), directing the mark (8) to the upper position.
- Refer to page S.6-53, regarding the adjustment of the bi-speed turn clutch turning torque.

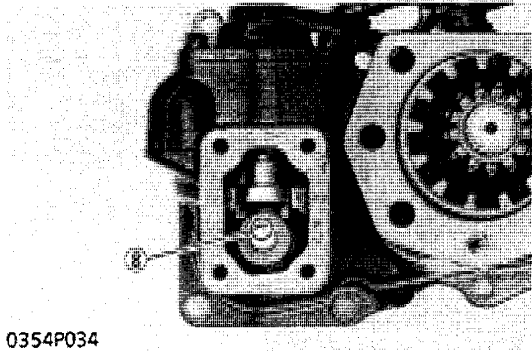

0354P034

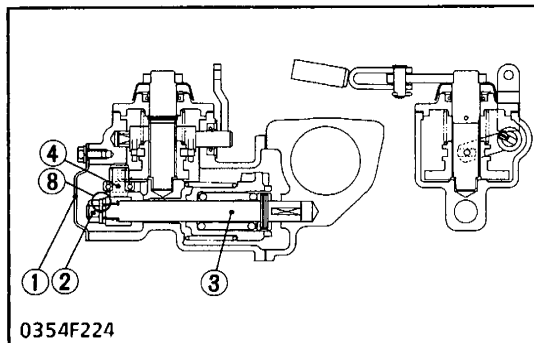

0354F224

Tightening torque	
Shift rod nut	
62.8 to 72.5 N·m	
6.4 to 7.4 kgf·m	
46.3 to 53.5 ft·lbs	

Bi-speed Turn Clutch Gear

1. Remove the needle bearing (11), collar with oil line (12), bi-speed turn shifter (13), shift spline boss (14), clutch boss (15), clutch disc (16), clutch friction plate (17), collar (18), clutch gear (19), needle bearing (20), collar (21) and front differential gear assembly (22), in order.

- | | |
|----------------------------|---------------------------------------|
| (11) Needle Bearing | (17) Clutch Friction Plate |
| (12) Collar | (18) Collar |
| (13) Bi-speed Turn Shifter | (19) Clutch Gear |
| (14) Shift Spline Boss | (20) Needle Bearing |
| (15) Clutch Boss | (21) Collar |
| (16) Clutch Disc | (22) Front Differential Gear Assembly |

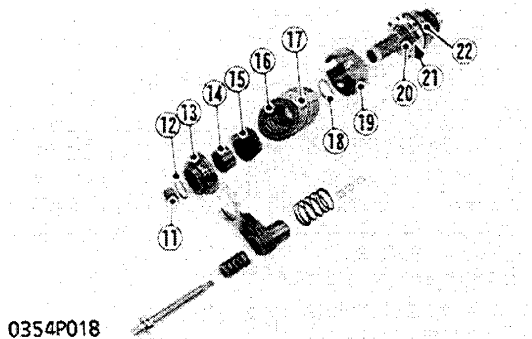

0354P018

Differential Gear Assembly

1. Secure the differential gear assembly in a vise.
2. Remove the right ball bearing (8) with a puller.
3. Remove the left bearing holder (10) and bearing (2).
4. Remove the front diff. shaft mounting screws (12).
5. Remove the front diff. shaft (11) from the differential case (9).

(When reassembling)

- Apply liquid lock to the front diff. shaft mounting screws.
- Take care of the direction of the bearing holder.

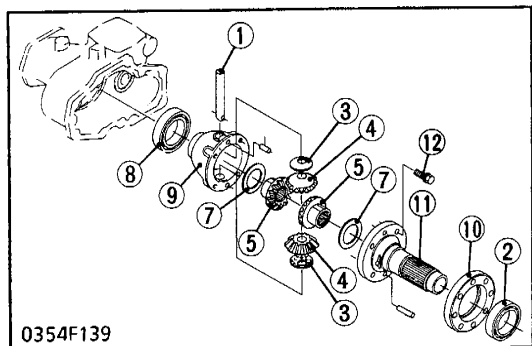

0354F139

- | | |
|--------------------------------|---------------------------------------|
| (1) Differential Pinion Shaft | (7) Shim |
| (2) Ball Bearing | (8) Ball Bearing |
| (3) Differential Pinion Collar | (9) Differential Case |
| (4) Differential Pinion | (10) Bearing Holder |
| (5) Differential Side Gear | (11) Front Diff. Shaft |
| | (12) Front Diff. Shaft Mounting Screw |

Tightening torque	Front diff. shaft mounting screw	29.4 to 34.3 N·m 3.0 to 3.5 kgf·m 21.7 to 25.3 ft·lbs
-------------------	----------------------------------	---

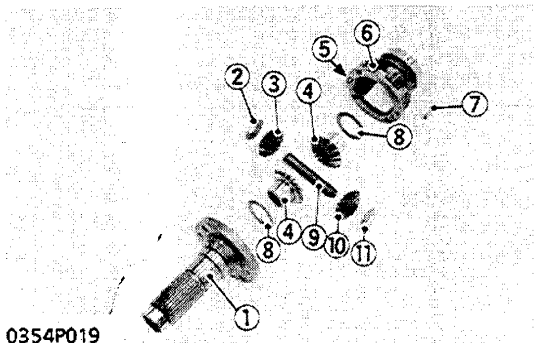

0354P019

- | | |
|--------------------------------|---------------------------------|
| (1) Front Diff. Shaft | (7) Straight Pin |
| (2) Differential Pinion Collar | (8) Shim |
| (3) Differential Pinion | (9) Differential Pinion Shaft |
| (4) Differential Side Gear | (10) Differential Pinion |
| (5) Dowel Pin | (11) Differential Pinion Collar |
| (6) Differential Case | |

Differential Side Gear and Differential Pinion

1. Put parting marks in the differential pinion and differential side gear.
2. Tap out the straight pin (7) and remove the differential pinion shaft (9).
3. Remove the differential pinion (3), (10), differential pinion collar (2), (11), differential side gear (4), shim (8).

(When reassembling)

- Install the differential pinion and differential side gear, aligning the parting marks.

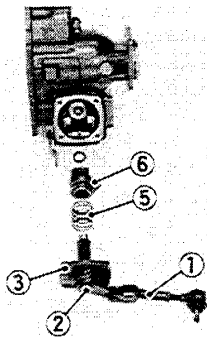

0354P020

Shift Cam

1. Remove the bi-speed shift link (1) from the shift lever (2).
2. Remove the shift lever fulcrum (3) mounting screws.
3. Pull out the shift lever with its fulcrum.

(When replacing the oil seal (4)).

- Remove the spring pin (8) from the shift lever.
- Separate the shift lever from the shift lever fulcrum (3).
- Remove the oil seal in the shift lever fulcrum.

4. Remove the spring (5), shift cam (6) and collar (7).

- | | |
|-------------------------|---------------------|
| (1) Shift Link | (6) Shift Cam |
| (2) Shift Lever | (7) Collar |
| (3) Shift Lever Fulcrum | (8) Spring Pin |
| (4) Oil Seal | (9) Alignment Marks |
| (5) Spring | |

(When reassembling)

- Install the shift lever to the shift cam, aligning its marks.

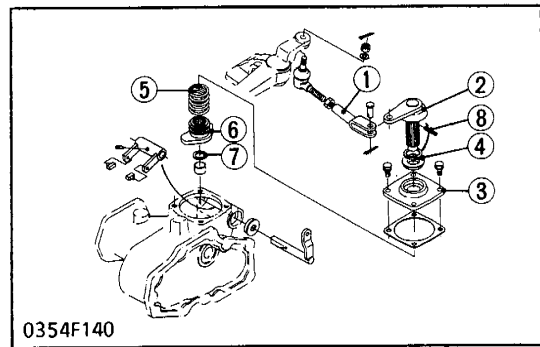

0354F140

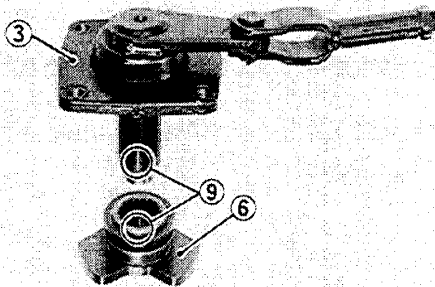

0354P035

SERVICING

Clearance between Differential Side Gear Boss and Differential Case Bore

Refer to S.6-22, 30.

Clearance between Differential Pinion Shaft and Differential Pinion (Bushing)

Refer to S.6-30, 22.

Backlash between Differential Pinion and Differential Side Gear

1. Secure the differential case in a vise.
2. Set a dial indicator (lever type) on the tooth of the differential side gear.
3. Hold the differential pinion and move the differential side gear to measure the backlash.
4. If the measurement exceeds the allowable limit, adjust with the differential side gear shim.



0354P021

Backlash between differential pinion and differential side gear	Factory spec.	0.10 to 0.30 mm 0.0039 to 0.0118 in.
	Allowable limit	0.40 mm 0.0157 in.

(Reference)

- Thickness of shims: 0.8 mm (0.0315 in.)
1.0 mm (0.0384 in.)
1.2 mm (0.0472 in.)

Turning Torque of Spiral Bevel Pinion Shaft

1. Secure the spacer in a vise.
2. Wind a string around the spiral bevel pinion shaft and attach a spring balance to the tip of the string.
3. Slowly pull the spring balance in a direction at right angle to the spiral bevel pinion shaft to measure the turning torque.
4. If the turning torque is not within the factory specifications, adjust with the staking nut.

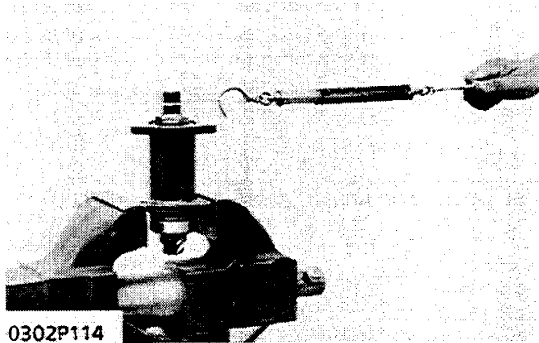

0302P114

Turning torque	Spiral bevel pinion shaft	1.27 to 1.67 N·m 0.13 to 0.17 kgf·m 0.94 to 1.23 ft-lbs
----------------	---------------------------	---

NOTE

- The turning torque is figured by multiplying the radius of the spiral bevel pinion shaft by the reading on the spring balance.
- Stake the staking nut after performing adjustment, as shown in the figure.

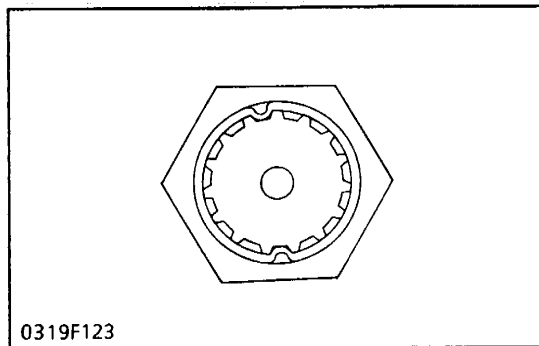

0319F123

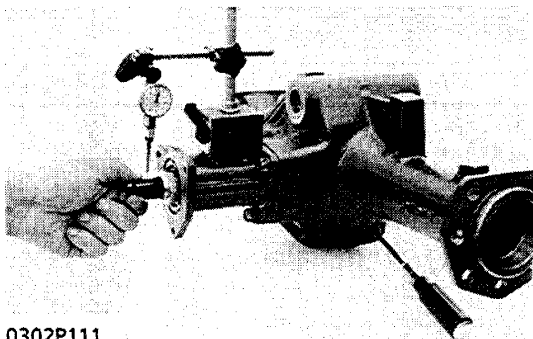

0302P111

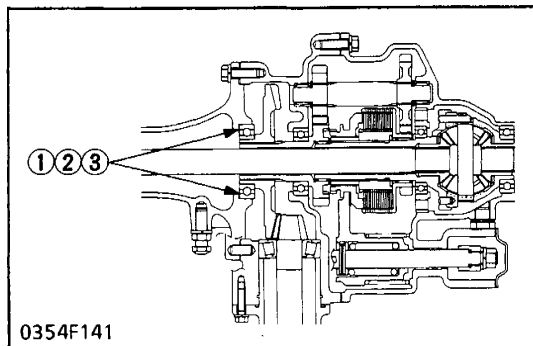

0354F141

Backlash between Spiral Bevel Pinion and Spiral Bevel Gear

1. Insert a screwdriver through the drain plug hole in the front axle arm to hold the 37T spiral bevel gear.
2. Set the dial indicator (lever type) with its finger on the spiral bevel pinion shaft.
3. If the backlash exceeds the allowable limit, insert the shim (1) to the front axle arm LH.
If the backlash is less than the factory specification, remove the shims at the front axle arm LH.
4. Adjust the backlash properly by repeating the above procedures.

Backlash between bevel gears in bevel gear case	Factory spec.	0.010 to 0.20 mm 0.0039 to 0.0079 in.
	Allowable limit	0.40 mm 0.016 in.

5. Apply red lead lightly over several teeth at three positions equally spaced on the bevel gear.
6. Turn the spiral bevel pinion shaft while pressing a wooden piece against the periphery of the bevel gear.
7. Check the tooth contact.

(Reference)

- Thickness of adjusting shims (1), (2), (3)
0.2 mm (0.008 in.), 0.3 mm (0.012 in.)
0.5 mm (0.020 in.)

Backlash of Bevel Gear in Bevel Gear Case

Refer to S.6-32.

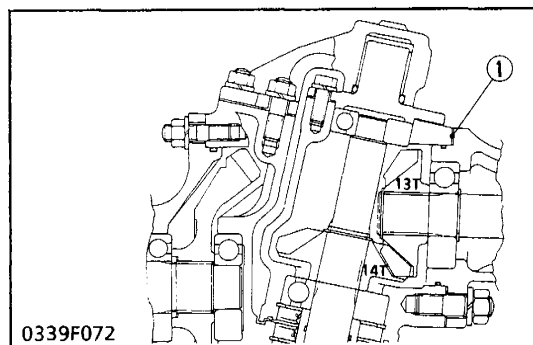

0339F072

Backlash between 13T bevel gear and 14T bevel gear	Factory spec.	0.10 to 0.30 mm 0.0039 to 0.0118 in.
	Allowable limit	0.40 mm 0.016 in.

Thickness of adjusting shims: 0.2, 0.3 mm
(0.008, 0.012 in.)

(1) Shim

Backlash of Bevel Gear in Front Axle Case

Refer to S.6-33.

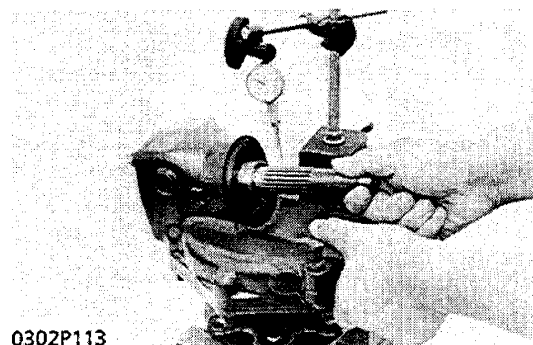

0302P113

Backlash between 16T bevel gear and 31T bevel gear	Factory spec.	0.10 to 0.20 mm 0.0039 to 0.0079 in.
	Allowable limit	0.40 mm 0.016 in.

Thickness of adjusting shims: 0.2, 0.5 mm
(0.008, 0.020 in.)

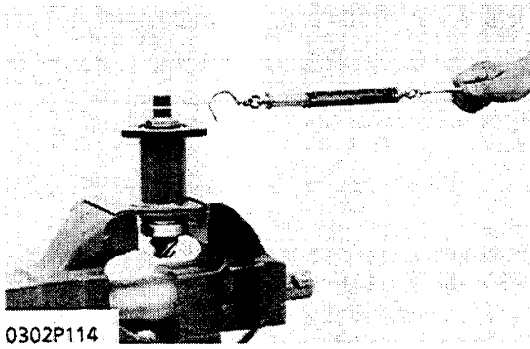

0302P114

Turning Torque of Bevel Pinion Shaft

Refer to S.6-23.31.

Turning torque of bevel pinion shaft	Spiral bevel pinion shaft.	1.27 to 1.67 N·m 0.13 to 0.17 kgf·m 0.94 to 1.23 ft-lbs
--------------------------------------	----------------------------	---

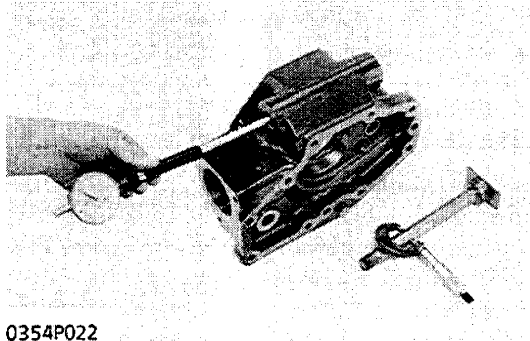

0354P022

Clearance between Center Pin and Bushing

Refer to S.6-24,33.

Clearance between center pin and bushing	Factory spec.	0.070 to 0.270 mm 0.0028 to 0.0106 in.
	Allowable limit	0.70 mm 0.0276 in.

Clearance between Knuckle Arm Support and Knuckle Arm Bushing

Clearance between Knuckle Arm Support and Knuckle Arm

Refer to S.6-33, 34.

Clutch Disc Wear and Friction Plate Wear

1. Measure the thickness of the clutch disc and friction plate (steel plate) with a vernier calipers.
2. If the thickness is less than the allowable limit, replace it.

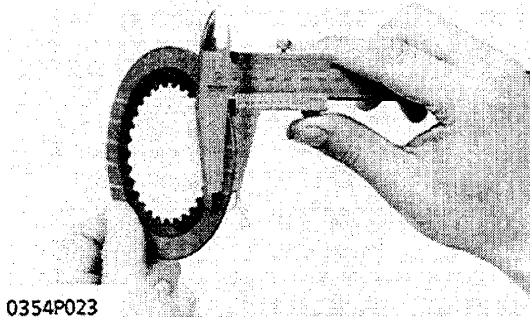

0354P023

Thickness of clutch disc	Factory spec.	2.1 to 2.2 mm 0.0827 to 0.0866 in.
	Allowable limit	1.7 mm 0.0669 in.

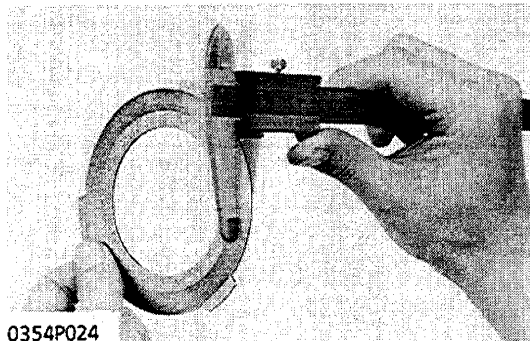

0354P024

Thickness of friction plate	Factory spec.	1.45 to 1.55 mm 0.0571 to 0.0610 in.
	Allowable limit	1.2 mm 0.0472 in.

(When reassembling)

- After keeping clutch discs in transmission oil for a several second and apply transmission oil to friction plate, reassembling them in order.

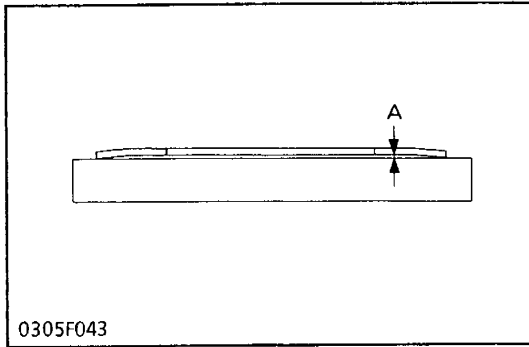

Displacement of Friction Plate

1. Place the friction plate on the surface table to measure the displacement (A) of the plate with a feeler gauge.
2. If the displacement is less than 0.1 mm (0.0039 in.) or exceeds 0.8 mm (0.0315 in.), replace the plate.

Displacement of friction plate	Factory spec.	0.2 to 0.6 mm 0.0079 to 0.0235 in.
	Allowable limit	0.1 mm, 0.0039 in. or 0.8 mm, 0.0315 in.

Toe-in , Front Wheel Steering Angle, Camber Angle, Caster Angle, Kingpin Inclination, Sway of Front Wheel, Rocking Angle

Refer to S.6-10 to S.6-12.

Bi-speed Turn Shift Lever Linkage Adjustment

Refer to S.6-13.

NOTE

- (Continued from page S.6-48)

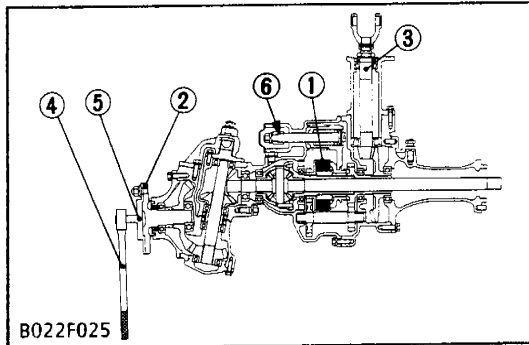

- (1) Bi-speed Turn Clutch
- (2) Front Wheel Hub
- (3) Front Pinion
- (4) Torque Wrench
- (5) Jig
- (6) Shim

Bi-speed Turn Clutch Friction Torque

1. Disconnect the front drive shaft.
2. Jack up the front axle and remove both front tires.
3. Engage the bi-speed turn operating lever and fully turn the steering wheel to the left (or right).
4. After fixing the left (or right) front wheel hub (2), and the front pinion (3), set the torque wrench (4) with the special jig (5) on the right (or left) front wheel hub.
5. When the bi-speed turn clutch is slipped, measure its torque.
6. If the torque is not within the factory specifications, adjust it with the shims (6).

Dynamic friction torque of bi-speed turn clutch	Factory spec.	245.2 to 284.4 N·m 25 to 29 kgf·m 180.8 to 209.8 ft·lbs
---	---------------	---

(Reference)

- Thickness of shims.
1.0 mm (0.039 in.), 1.5 mm (0.059 in.)
- Decreasing 1.0 mm (0.039 in.) shim changes the dynamic friction torque of the clutch by 2 to 4 kgf·m (14.5 to 28.9 ft·lbs).

NOTE

- Check the springs, clutch discs and friction plates if the correct torque can't be adjusted.

CONTENTS

TROUBLESHOOTING	S.7-1
MANUAL STEERING TYPE	S.7-1
POWER STEERING TYPE	S.7-2
SERVICING SPECIFICATIONS	S.7-3
MANUAL STEERING TYPE	S.7-3
POWER STEERING TYPE	S.7-3
TIGHTENING TORQUES	S.7-6
CHECKING, DISASSEMBLING AND SERVICING	S.7-7
CHECKING AND ADJUSTING	S.7-7
[MANUAL STEERING]	S.7-7
[POWER STEERING]	S.7-8
[1] MANUAL STEERING	
[B1550-B1750-B1550HST-B1750HST]	
DISASSEMBLING AND ASSEMBLING	S.7-9
SERVICING	S.7-11
[B2150-B2150HST]	
DISASSEMBLING AND ASSEMBLING	S.7-12
SERVICING	S.7-14
[2] POWER STEERING	
[B1550-B1750-B1550HST-B1750HST]	
DISASSEMBLING AND ASSEMBLING	S.7-15
SERVICING	S.7-20
[B2150-B2150HST]	
DISASSEMBLING AND ASSEMBLING	S.7-22
SERVICING	S.7-27

TROUBLESHOOTING

MANUAL STEERING TYPE

Symptom	Probable Cause	Solution	Reference Page
Excessive Steering Wheel Play	<ul style="list-style-type: none"> ● Backlash between sector gear shaft and ball nut too large ● Steering linkage worn ● Sector gear shaft worn 	Adjust	S.7-7
		Replace Replace	— S.7-10,13
Steering Wheel Does Not Return to Neutral Position	<ul style="list-style-type: none"> ● Ball nut malfunctioning 	Replace	S.7-11,13
Hard Steering	<ul style="list-style-type: none"> ● Steering wheel play too small ● Improper front wheel alignment ● Insufficient tire pressure ● Thrust ball bearing damaged ● Insufficient steering gear box oil 	Adjust Adjust Inflate Replace Refill	S.7-7 S.6-10 M.10-4,5 S.7-11,13 S.G-15
Tractor Pulls to Right or Left	<ul style="list-style-type: none"> ● Tire pressure uneven ● Steering wheel play too small ● Improper toe-in adjustment ● Front wheel hub ball bearing worn or damaged ● Brake pedal play unevenly adjusted 	Adjust Adjust Adjust Replace Adjust	M.10-4,5 S.7-7 S.6-10 S.6-13 S.5-2
Front Wheels Vibration	<ul style="list-style-type: none"> ● Steering linkage worn ● Improper toe-in adjustment ● Knuckle shaft bushing worn [2WD] ● Clearance between center pin and bushing excessive 	Replace Adjust Replace Replace	— S.6-10 S.6-16 S.6-15, 16
Tractor Cannot Be steering	<ul style="list-style-type: none"> ● Steering gear broken ● Sector shaft broken ● Steering shaft broken ● Steering linkage broken (tie rod and tie rod end, drag link) ● Knuckle shaft and knuckle arm broken 	Replace Replace Replace Replace Replace	S.7-11,13 S.7-10,13 S.6-14,17, 26,35,36,44 S.6-14,26 35,36,45
Front Tire Shimmy	<ul style="list-style-type: none"> ● Steering linkage worn (tie rod end, drag link end) ● Clearance between center pin and pin support excessive (2WD Type) ● Clearance between center pin and bushing excessive (4WD Type) ● Improper toe-in adjustment ● Knuckle shaft bushing worn (2WD Type) 	Replace Replace Adjust Replace	— S.6-15 S.6-24,33 S.6-10 S.6-16

POWER STEERING TYPE

Symptom	Probable Cause	Solution	Reference Page
Excessive Steering Wheel Play	<ul style="list-style-type: none"> ● Backlash between sector gear shaft and ball nut too large ● Steering linkage worn ● Sector gear shaft worn ● Centering spring weaken or broken 	Adjust Replace Replace Replace	S.7-7 — S.7-21,28 S.7-18,25
Tractor Pulls to Right or Left	<ul style="list-style-type: none"> ● Tire pressure uneven ● Steering wheel play too small ● Improper toe-in adjustment ● Front wheel hub ball bearing worn or damaged ● Brake pedal play unevenly adjusted 	Adjust Adjust Adjust Replace Adjust	M 10-4,5 S.7-8 S.6-10 S.6-13 S.5-2
Front Wheels Vibration	<ul style="list-style-type: none"> ● Steering linkage worn ● Improper toe-in adjustment ● Knuckle shaft bushing worn [2WD] ● Clearance between center pin and bushing 	Replace Adjust Replace Replace	— S.6-10 S.6-16 S.6-15,16
Hard Steering	<ul style="list-style-type: none"> ● Transmission fluid improper or insufficient ● Oil leak from pipe joint ● Hydraulic pump malfunctioning ● Relief valve malfunctioning ● Seals in the steering gear box damaged ● Backlash between sector gear shaft and ball nut too small ● Air in the hydraulic pipes ● Low operating pressure 	Change Retighten Replace Adjust or Replace Replace Adjust Air vent Refer to next item	S.G-3 — S.8-6,7 S.7-8,9,16 23 S.7-20,27 S.7-7,8 — —
Low Operating Pressure	<ul style="list-style-type: none"> ● Hydraulic pump malfunctioning ● Improper relief valve adjustment ● Control valve malfunctioning ● Seals in the steering gear box damaged ● Ball nut malfunctioning ● Oil leak from pipe or pipe broken 	Replace Adjust Replace Replace Replace ball nut assembly Replace	S.8-6,7,8,9 S.7-8,9 S.7-8,9,16 23 S.7-20,26, 27 S.7-20,26 —
Steering Wheel Does Not Return to Neutral Position	<ul style="list-style-type: none"> ● Control valve malfunctioning ● Valve spool and valve housing jammed ● Valve housing oil seal damaged ● Centering spring weaken or broken 	Replace Repair or Replace Replace Replace	S.7-8,9,16 23 S.7-16,17, 23,24 S.7-16,17 23,24 S.7-18,25
Steering Force Fluctuates	<ul style="list-style-type: none"> ● Insufficient oil ● Insufficient bleeding ● Control valve malfunctioning 	Replenish Bleed Replace	S.G-3 S.7-8 S.7-8,9,16 23
Noise	<ul style="list-style-type: none"> ● Insufficient oil ● Air sucked in pump from suction circuit ● Pipe deformed 	Replenish Repair Replace	S.G-3 — —

SERVICING SPECIFICATIONS

MANUAL STEERING TYPE

[B1550-B1750-B1550HST-B1750HST]

Item		Factory Specification	Allowable Limit
Steering Wheel	Play	5 to 30 mm 0.2 to 1.2 in.	–
Ball Nut Assembly	Axial Play	–	0.2 mm 0.008 in.
Steering Shaft	Turning Torque (with Seal and Sector Shaft, w/o Bushing)	0.441 to 0.981 N·m 0.045 to 0.100 kgf·m 0.325 to 0.723 ft-lbs	–
	Turning Torque (w/o Bushing, Seal and Sector Shaft)	0.245 to 0.490 N·m 0.025 to 0.050 kgf·m 0.181 to 0.362 ft-lbs	–
Adjusting Shim	Thickness	0.05 mm, 0.0020 in. 0.08 mm, 0.0031 in. 0.10 mm, 0.0039 in. 0.20 mm, 0.0079 in.	–

[B2150-B2150HST]

Steering Wheel	Play	5 to 30 mm 0.2 to 1.2 in.	–
Ball Nut Assembly	Axial Play	–	0.2 mm 0.008 in.
Steering Shaft	Turning Torque (with Bushing, Seal and Sector Shaft)	Less than 1.72 N·m 0.175 kgf·m 1.27 ft-lbs	–
	Turning Torque (w/o Bushing, Seal and Sector Shaft)	0.25 to 0.54 N·m 0.025 to 0.055 kgf·m 0.181 to 0.398 ft-lbs	–

POWER STEERING TYPE

[B1550-B1750-B1550HST-B1750HST]

Steering Wheel	Play	Less than 30 mm 1.2 in.	–
	Operation Force Condition: • Engine Speed Approx. 2600 rpm	Less than 5.9 N 0.6 kgf. 1.3 lbs.	–
Relief Valve	Setting Pressure Condition: • Engine Speed: Approx. 2600 rpm • Oil Temperature: 40° to 50° 104° to 122°F	10.30 to 11.28 MPa 105 to 115 kgf/cm ² 1493 to 1636 psi	–

[B1550-B1750-B1550HST-B1750HST] (Continued)

Item		Factory Specification	Allowable Limit
Steering Gear Box to Ball Nut	Clearance	0.030 to 0.079 mm 0.00118 to 0.00311 in.	0.15 mm 0.0059 in.
Gear Box Bore	I.D.	56.000 to 56.030 mm	-
Ball Nut	O.D.	2.2047 to 2.20591 in. 54.951 to 54.970 mm 2.16343 to 2.16417 in.	-
Bull Nut Assembly	Axial Play	0 to 0.05 mm 0 to 0.0020 in.	
Valve Housing to Spool	Clearance	0.005 to 0.020 mm 0.00020 to 0.00079 in.	0.04 mm 0.0016 in.
Spool	O.D.	28.000 to 28.005 mm	-
Valve housing	I.D.	1.10236 to 1.10256 in. 28.010 to 28.020 mm 1.10276 to 1.10315 in.	-
Valve housing to Piston	Clearance	0.005 to 0.030 mm 0.00020 to 0.00118 in.	0.06 mm 0.0024 in.
Piston	O.D.	9.990 to 10.005 mm	-
Valve housing	I.D.	0.39331 to 0.39390 in. 10.010 to 10.020 mm 0.39409 to 0.39449 in.	-
Sector Gear Shaft			
Steering Gear Box Side	O.D.	27.997 to 28.000 mm 1.10224 to 1.10236 in.	27.900 mm 1.09843 in.
Side Cover Side	I.D.	25.997 to 26.000 mm 1.02350 to 1.02362 in.	25.900 mm 1.01969 in.
Steering Gear Box to Sector Gear Shaft	Clearance	0.020 to 0.033 mm 0.00079 to 0.00130 in.	0.10 mm 0.0039 in.
Steering Gear Box	I.D.	28.020 to 28.030 mm	-
Side Cover	I.D.	1.10315 to 1.10354 in. 26.020 to 26.030 mm 1.02441 to 1.02480 in.	-
Sector Gear Shaft to Ball Nut	Backlash Deflection measured at piston arm end	Less than 0.30 mm 0.0118 in.	-
Worm Shaft	Turning Torque	Less than 1.18 N-m 0.12 kgf-m 0.87 ft-lbs.	-

POWER STEERING TYPE
[B2150-B2150HST]

Item		Factory Specification	Allowable Limit
Steering Wheel	Play	Less than 30 mm 1.2 in.	—
	Operation Force Condition: • Engine Speed Approx. 2600 rpm	Less than 5.9 N 0.6 kgf. 1.3 lbs.	—
Relief Valve	Setting Pressure Condition: • Engine Speed: Approx. 2600 rpm • Oil Temperature: 40 to 50° 104 to 122°F	12.75 to 13.24 MPa 130 to 135 kgf/cm ² 1849 to 1920 psi	—
Steering Gear Box to Ball Nut	Clearance	0.030 to 0.079 mm 0.00118 to 0.00311 in.	0.15 mm 0.0059 in.
	Gear Box Bore I.D.	61.000 to 61.030 mm 2.40158 to 2.40276 in.	—
	Ball Nut O.D.	60.951 to 60.970 mm 2.39965 to 2.40040 in.	—
Ball Nut Assembly	Axial Play	Less than 0.020 mm 0.00079 in.	—
Worm Shaft	Top Cover Side O.D.	19.996 to 20.009 mm 0.78724 to 0.78776 in.	19.900 mm 0.78346 in.
	Ball Nut Side O.D.	24.996 to 25.009 mm 0.98410 to 0.98461 in.	24.900 mm 0.98031 in.
	End Cover Side O.D.	24.996 to 25.009 mm 0.98410 to 0.98461 in.	24.900 mm 0.98031 in.
Valve Housing to Spool	Clearance	0.008 to 0.015 mm 0.00031 to 0.00059 in.	0.025 mm 0.00098 in.
Sector Gear Shaft	Steering Gear Box Side O.D.	34.957 to 35.000 mm 1.37626 to 1.37795 in.	34.900 mm 1.37402 in.
	Side Cover Side O.D.	27.987 to 28.000 mm 1.10185 to 1.10236 in.	27.900 mm 1.09843 in.
Sector Gear Shaft to Ball Nut	Backlash Deflection measured at pitman arm end	Less than 0.30 mm 0.0118 in.	—
Worm Shaft	Turning Torque	Less than 1.18 N·m 0.12 kgf·m 0.87 ft·lbs	—

TIGHTENING TORQUES

Tightening torques of screws and nuts on the table below are especially specified.
(For general use screws and nuts: See page S.G-4)

MANUAL STEERING TYPE

Item	N·m	kgf·m	ft-lbs
Tie rod end and drag link end slotted nut	48.1 to 55.8	4.9 to 5.7	35.4 to 41.2
Tie rod lock nut	68.6 to 88.3	7.0 to 9.0	50.6 to 65.1
Pitman arm mounting nut			
[B1550-B1750-B1550HST-B1750HST]	98.1 to 147.1	10.0 to 15.0	72.3 to 108.5
[B2150-B2150HST]	117.7 to 156.9	12.0 to 16.0	86.8 to 115.7
Steering post mounting screw			
[B1550-B1750-B1550HST-B1750HST]	18.6 to 32.4	1.9 to 3.3	13.7 to 23.9
Steering assembly mounting nut			
[B1550-B1750-B1550HST-B1750HST]	39.2 to 64.7	4.0 to 6.6	28.9 to 47.7
[B2150-B2150HST]	48.1 to 55.8	4.9 to 5.7	35.4 to 41.2
Steering assembly mounting stud			
[B1550-B1750-B1550HST-B1750HST]	39.2 to 64.7	4.0 to 5.0	28.9 to 36.2
[B2150-B2150HST]	24.5 to 31.4	2.5 to 3.2	18.1 to 23.1
Steering wheel mounting nut	29.4 to 49.0	3.0 to 5.0	21.7 to 36.2
Column lock nut	157 to 196	16 to 20	115.8 to 144.6
Side cover mounting screw			
[B1550-B1750-B1550HST-B1750HST]	13.7 to 19.6	1.4 to 2.0	10.1 to 14.5
[B2150-B2150HST]	23.5 to 27.5	2.4 to 2.8	17.4 to 20.3

POWER STEERING TYPE

Tie rod end and drag link end slotted nut	48.1 to 55.8	4.9 to 5.7	35.4 to 41.2
Tie rod lock nut	68.6 to 88.3	7.0 to 9.0	50.6 to 65.1
Pitman arm mounting nut			
[B1550-B1750-B1550HST-B1750HST]	98.1 to 147.1	10.0 to 15.0	72.3 to 108.5
[B2150-B2150HST]	117.7 to 156.9	12.0 to 16.0	86.8 to 115.7
Power steering assembly mounting nut			
[B1550-B1750-B1550HST-B1750HST]	39.2 to 64.7	4.0 to 6.6	28.9 to 47.7
[B2150-B2150HST]	48.1 to 55.8	4.9 to 5.7	35.4 to 41.2
Power steering assembly mounting stud			
[B1550-B1750-B1550HST-B1750HST]	39.2 to 49.0	4.0 to 5.0	28.9 to 36.2
[B2150-B2150HST]	24.5 to 31.4	2.5 to 3.2	18.1 to 23.1
Power steering delivery and return pipe end eye joint bolt	39.2 to 44.1	4.0 to 4.5	28.9 to 32.5
Steering wheel mounting nut	29.4 to 49.0	3.0 to 5.0	21.7 to 36.2
Column lock nut	98.1 to 127.5	10.0 to 13.0	72.3 to 94.0
Top cover mounting screw			
[B1550-B1750-B1550HST-B1750HST]	23.5 to 27.5	2.4 to 2.8	17.4 to 20.3
[B2150-B2150HST]	37.3 to 56.9	3.8 to 5.8	27.5 to 42.0
Relief valve lock nut [B2150-B2150HST]	49.0 to 78.5	5.0 to 8.0	36.2 to 57.9
Adjusting screw lock nut			
[B1550-B1750-B1550HST-B1750HST]	39.2 to 45.1	4.0 to 4.6	28.9 to 33.3
Adjusting screw lock nut and cap nut [B2150-B2150HST]	19.6 to 29.4	2.0 to 3.0	14.5 to 21.7
Side cover mounting screw			
[B1550-B1750-B1550HST-B1750HST]	23.5 to 27.5	2.4 to 2.8	17.4 to 20.3
[B2150-B2150HST]	37.3 to 56.9	3.8 to 5.8	27.5 to 42.0

CHECKING, DISASSEMBLING AND SERVICING

CHECKING AND ADJUSTING

[MANUAL STEERING]

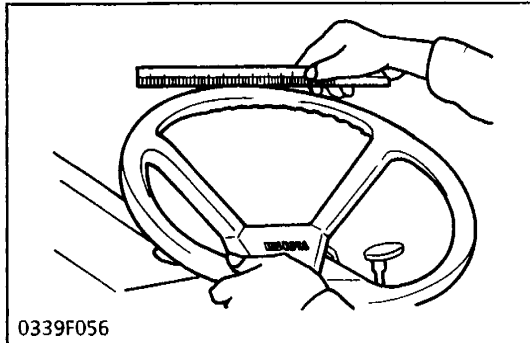

Steering Wheel Play

1. Turn the front wheels straight ahead.
2. Rotate the steering wheel lightly by hand, and measure the play with a rule.
3. If the play is not within the factory specifications, turn the adjusting screw (2) to adjust.

Steering wheel play	Manual steering	Factory spec.	5 to 30 mm 0.2 to 1.2 in.
	Power steering	Factory spec.	Less than 30 mm, 1.2 in.

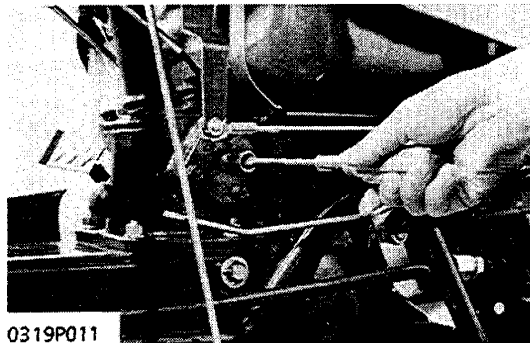

(Adjusting)

[B1550.B1750.B1550HST.B1750HST]

1. When the play is excessive, remove the rubber plug and turn the adjusting screw clockwise, and when too little, counterclockwise.
2. After adjustment, secure the adjusting screw with the lock nut.



[B2150-B2150HST]

1. Remove the cap nut (1), loosen the lock nut (3) and turn the adjusting screw (2) with a screwdriver to adjust the play. When the adjusting screw (2) is turned clockwise, the play decreases.
2. After adjustment, while holding the adjusting screw (2), fix it with the lock nut (3).

- (1) Cap Nut
- (2) Adjusting Screw
- (3) Lock Nut

[POWER STEERING]

■ IMPORTANT

- Use only the transmission fluid (See page S.G-3), in no case use mixture of oils of different brands.
- Do not disassemble the hydraulic pump and power steering needlessly.
- After removing or disassembling the power steering hydraulic components, be sure to bleed air.

(Bleeding)

- Start the engine, then turn the steering wheel slowly in both directions all the way alternately several times, and stop the engine.

Steering Wheel Play

1. Refer to S.7-7.

Power steering wheel play	Factory spec.	Less than	30 mm 1.2 in
---------------------------	---------------	-----------	-----------------

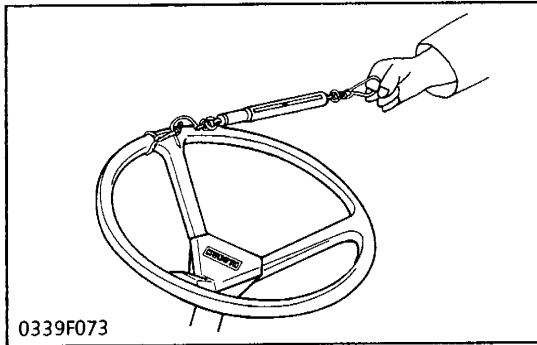

Steering Wheel Operating Force

1. Park the tractor on flat concrete place.
2. Start the engine. After warming up, set the engine speed at approx. 2600 rpm.
3. Set a spring balance to the steering wheel to measure the operating force.
4. If the measurement exceeds the factory specification, check the suction line, delivery line, hydraulic block type outlet and the performance of hydraulic pump with a flowmeter. (See page S.8-6,7)
And Then, check the power steering assembly.

Steering wheel operating force	Factory spec.	Less than	5.9 N 0.6 kgf 1.3 lbs
--------------------------------	---------------	-----------	-----------------------------

[B1550-B1750-B1550HST-B1750HST]

Relief Valve Setting Pressure

1. Remove the panel board, bonnet cover, and bonnet rear cover and move fuel tank to make space for loosening the delivery pipe and its nipple on the power steering valve.
2. Remove the delivery pipe and its nipples on the p.s. valve and hydraulic outlet.
3. Set Adaptors 51. (Code No: 07916-52831) on them and connect P.S. Adaptor (Code No: 07916-54021) mounted relief valve setting pressure gauge (Code No: 07916-50045) and PF1/8 size hose (Code No: 07916-52651) in order with Adaptors 51.
4. Start the engine and set at approx. 2600 rpm.
5. Fully turn the steering wheel to the left or right end to read the relief pressure. After reading, stop the engine.
6. If the pressure is not factory specification, check the pump delivery line, adjust the relief valve setting pressure (Refer to "Adjusting Relief Valve Setting Pressure" in the next page.)

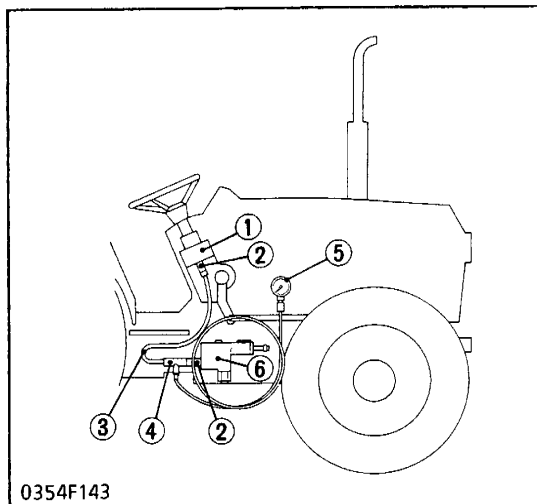

- | | |
|----------------------------|---------------------------------|
| (1) Power Steering Valve | (5) Pressure Gauge |
| (2) Adaptor 51 | (6) Hydraulic Block Type Outlet |
| (3) Hose | |
| (4) Power Steering Adaptor | |

Power steering relief valve setting pressure	Factory spec.	10.30 to 11.28 MPa 105 to 115 kgf/cm ² 1493 to 1636 psi
--	---------------	--

[B2150-B2150HST]

Relief Valve Setting Pressure

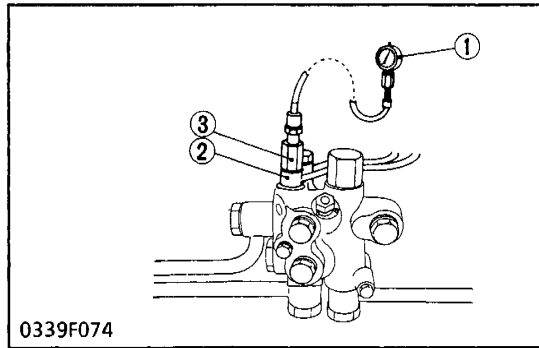

0339F074

- (1) Tester
- (2) Delivery Pipe
- (3) Adaptor

1. Remove the joint bolt on the delivery pipe (2) from the hydraulic block type outlet.
2. Attach the adaptor (3) (Screw size: M12 Pitch 1.2 mm) instead of the joint bolt. And install the relief valve setting pressure tester (1) (Code No.: 07916-50045) onto the adaptor (3). (Refer to the drawing in S.G-31)
3. Start the engine and set at approx. 2600 rpm.
4. Fully turn the steering wheel to the left or right end to read the relief pressure. After reading, stop the engine.
5. If the pressure is not factory specification, check the pump delivery line, adjust the relief valve setting pressure (see the next item) or repair the power steering.

Condition

- Engine speed ---- Approx. 2600 rpm

Power steering relief valve setting pressure	Factory spec.	12.75 to 13.24 MPa 130 to 135 kgf/cm ² 1849 to 1920 psi
--	---------------	--

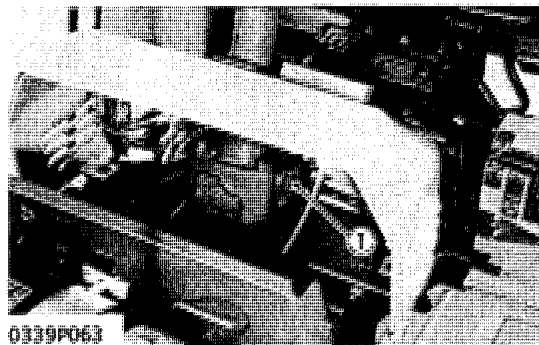

0339P063

- (1) Adjusting Screw

Adjusting Relief Valve Setting Pressure

1. Loosen the lock nut.
2. While the relief valve is operating, adjust the relief pressure by turning the adjusting screw (1). If it is turned clockwise, the relief pressure increases.
3. After adjustment, while holding the adjusting screw (1), fix it with lock nut and stake the screw (1) and nut with a punch to avoid loosening.

Relief valve setting pressure	Factory spec.	12.75 to 13.24 MPa 130 to 135 kgf/cm ² 1849 to 1920 psi
-------------------------------	---------------	--

Condition

- Engine speed ---- Approx. 2600 rpm

Tightening torque	Lock nut	49.0 to 78.5 N·m 5.0 to 8.0 kgf·m 36.2 to 57.9 ft·lbs
-------------------	----------	---

[1] MANUAL STEERING

[B1550-B1750-B1550HST-B1750HST]

This manual steering is based on that of B7200, but the following points have been modified.

1. Sector shaft, ball nut comp. and pitman arm have been modified.
2. Steering post and steering wheel have been modified.

DISASSEMBLING AND ASSEMBLING

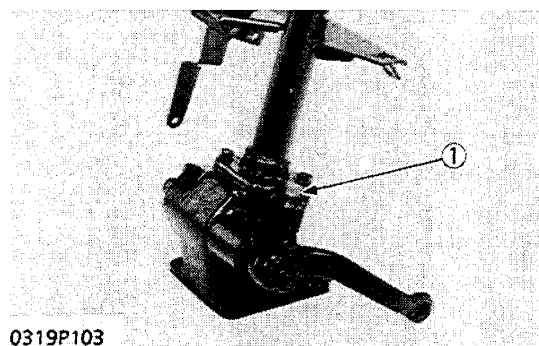

0319P103

- (1) Plug

Draining Oil

1. Remove the plug to drain gear oil.

Steering gear box	Capacity	0.2 ℓ 0.2 U.S. qts. 0.18 Imp. qts.
-------------------	----------	--

(Lubricants)

- Gear oil SAE 80 or SAE 90

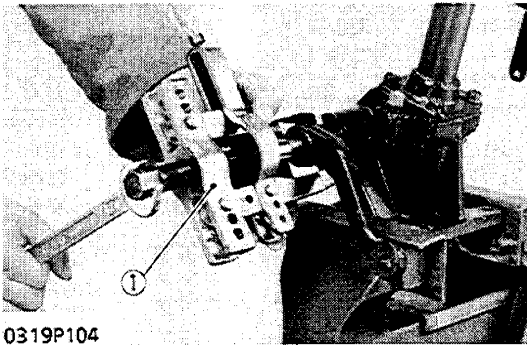

0319P104

Pitman Arm

1. Remove the pitman arm from the sector shaft with a pitman arm puller (1) (Code No: 07909-39011).

(When reassembling)

- Install the pitman arm to sector shaft, aligning their marks (2).

Tightening torque	Pitman arm mounting nut	98 to 147 N·m 10 to 15 kgf·m 72 to 108 ft·lbs
-------------------	-------------------------	---

- (1) Pitman Arm Puller
- (2) Marks

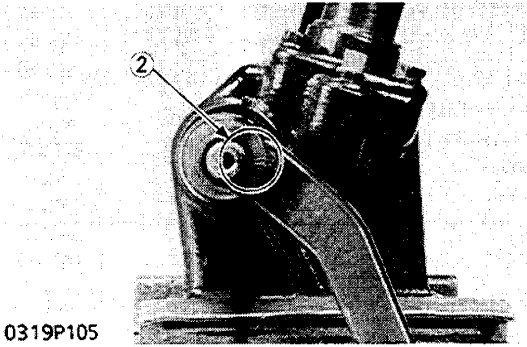

0319P105

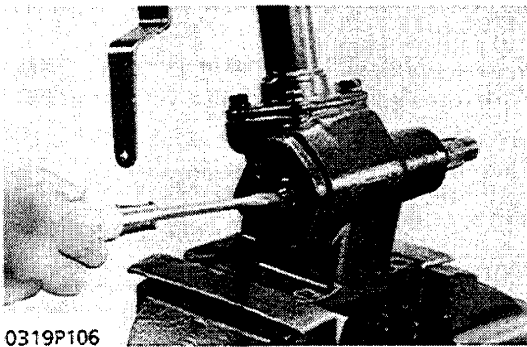

0319P106

Side Cover and Sector Shaft

1. Remove the side cover mounting screws.
2. Remove the rubber plug (1) and loosen the lock nut (2).
3. Rotating the adjusting screw (6) clockwise, remove the side cover (4).
4. Tap out the sector shaft (7) toward the side cover.

(When reassembling)

- Install the sector shaft to the steering gear box (9), using care not to damage the lip of the oil seal (10).
- Replace the gasket (8) with a new one, and apply liquid gasket (Three Bond 1104 or equivalent) to it.

Tightening torque	Side cover mounting screw	13.7 to 19.6 N·m 1.4 to 2.0 kgf·m 10.1 to 14.5 ft·lbs
-------------------	---------------------------	---

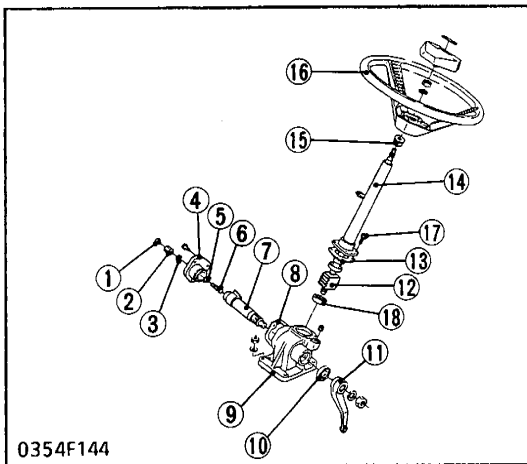

0354F144

- (1) Rubber Plug
- (2) Lock Nut
- (3) Copper Gasket
- (4) Side Cover
- (5) Adjusting Collar
- (6) Adjusting Screw
- (7) Sector Shaft
- (8) Gasket
- (9) Steering Gear Box
- (10) Oil Seal
- (11) Pitman Arm
- (12) Ball Nut Comp.
- (13) Shim
- (14) Steering Post
- (15) Post Bushing
- (16) Steering Wheel
- (17) Mounting Screw
- (18) Thrust Ball Bearing

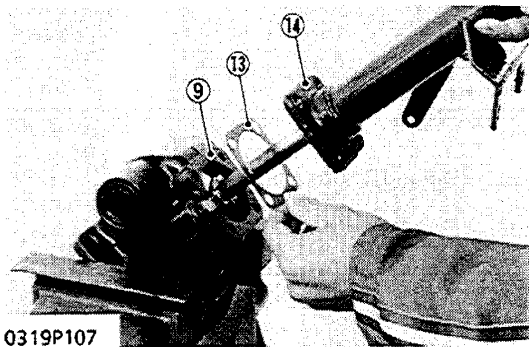

0319P107

Refer to 0354F144 illustration in S.7-10.

Steering Post and Ball Nut

1. Remove the mounting screws (17), then remove the steering post (14) noting the shims (13) between the steering post (14) and steering gear box (9).
2. Remove the ball nut (12).

(When reassembling)

- Rotate the sector shaft to raise the sector, and install the ball nut so that their lowest teeth mesh first.
- Make sure that the ball nut (12) is installed in the thrust ball bearing (18).
- Apply liquid gasket (Three Bond 1104 or equivalent) to the shim.

Tightening torque	Steering post mounting screw	18.6 to 32.4 N·m 1.9 to 3.3 kgf·m 13.7 to 23.9 ft-lbs
-------------------	------------------------------	---

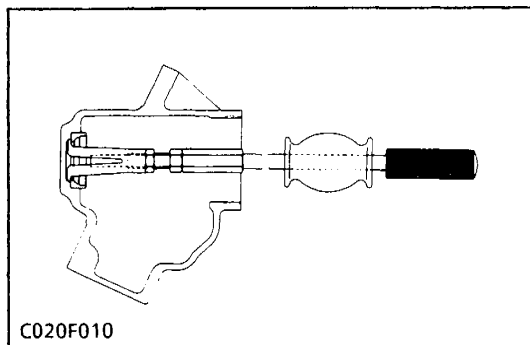

C020F010

Thrust Ball Bearing

1. Draw out the thrust ball bearing with a bushing puller set (Code No: 07916-51031).

SERVICING

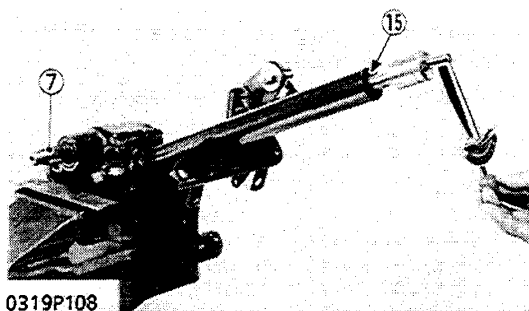

0319P108

Steering Shaft Initial Turning Torque

1. After removing the post bushing (15), secure the steering assembly in a vise.
2. Set a torque wrench on the steering shaft, and measure the torque required initial turning.

Steering shaft initial turning torque	Factory spec.	0.441 to 0.981 N·m 0.045 to 0.100 kgf·m 0.325 to 0.723 ft-lbs
---------------------------------------	---------------	---

3. If the torque is not within the factory specifications, measure the torque again with the sector shaft (7) removed.

Steering shaft initial turning torque (without sector shaft)	Factory spec.	0.245 to 0.490 N·m 0.025 to 0.050 kgf·m 0.181 to 0.362 ft-lbs
--	---------------	---

4. If the torque is not within the factory specifications, adjust with the shim (13).

(Reference)

- Thickness of shims: 0.05 mm (0.0020 in.)
0.08 mm (0.0031 in.)
0.10 mm (0.0039 in.)
0.20 mm (0.0079 in.)

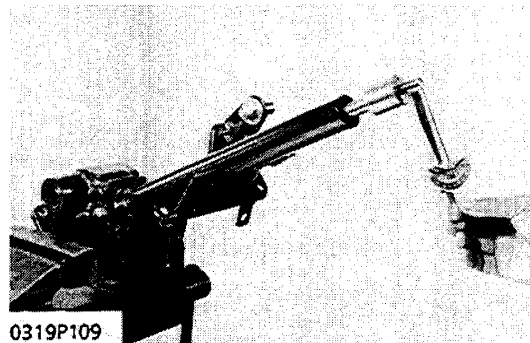

0319P109

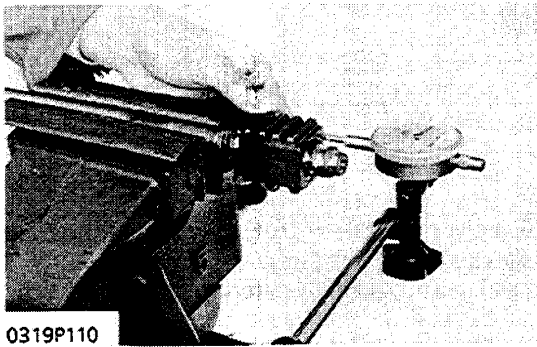

0319P110

Axial Play of Ball Nut

1. Secure the steering shaft with a vise.
2. Set a dial indicator to the ball nut.
3. Move the ball nut in axial direction by hand to measure the play.
4. If the play exceeds the allowable limit, replace.

Axial play of ball nut	Allowable limit	0.20 mm 0.0079 in.
------------------------	-----------------	-----------------------

■ **NOTE**

- Set the steering shaft horizontally.

[B2150-B2150HST]

This manual steering is the same as that of B9200.

DISASSEMBLING AND ASSEMBLING

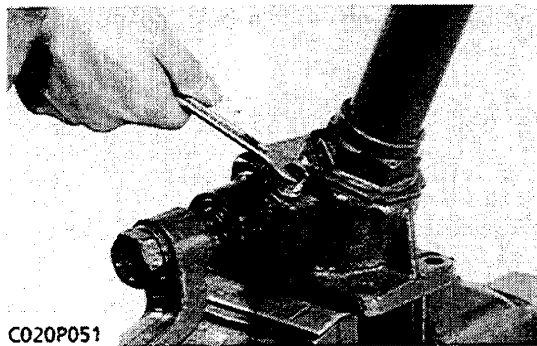

C020P051

Removing Steering Assembly

- See page S.5-21,27.

Draining Oil

1. Remove the plug to drain gear oil.

Place	Capacity	Lubricants
Steering gear box	0.2 ℓ 0.2 U.S. qts 0.2 Imp. qts	Gear oil SAE 80 or SAE 90

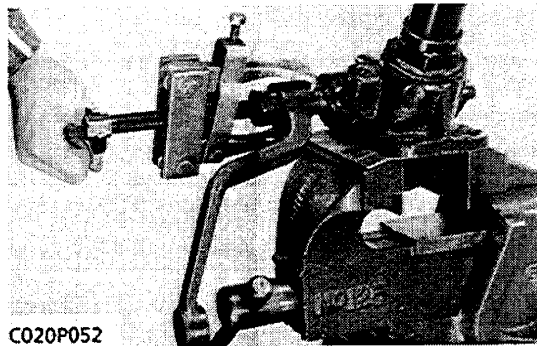

C020P052

Pitman Arm

1. Remove the pitman arm from the sector shaft with the pitman arm puller (Code No.: 07909-39011).

(When reassembling)

Tightening torque	Pitman arm mounting nut	117.7 TO 156.9 N·m 12.0 to 16.0 kgf·m 86.8 TO 115.7 ft-lbs
-------------------	-------------------------	--

■ **NOTE**

- Install the pitman arm to the sector shaft, aligning their marks (1).

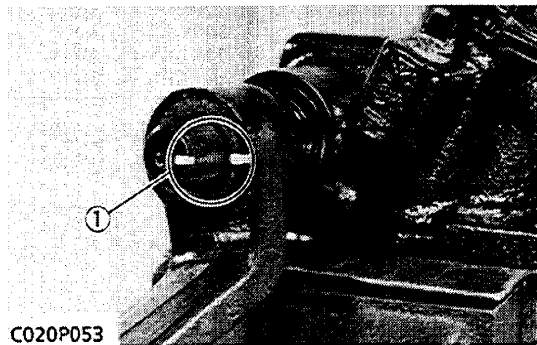

C020P053

(1) Marks

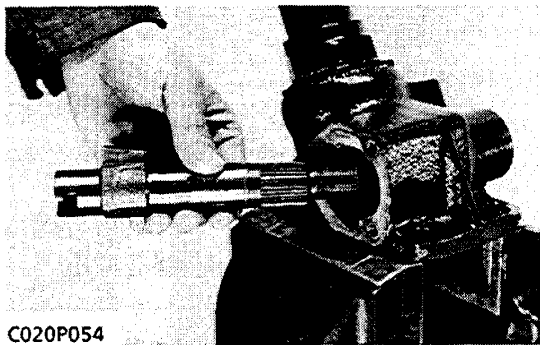

C020P054

Side Cover and Sector Shaft

1. Remove the side cover mounting screws.
2. Remove the lock nut (4) and cap nut (5) at the center of the side cover.
3. Turn the adjusting screw (3) clockwise to remove the side cover (2).
4. Tap out the sector shaft (1) toward the side cover.

(When reassembling)

- Apply liquid gasket. ("Three Bond 1215" or equivalent) to the mounting surface of side cover gasket.

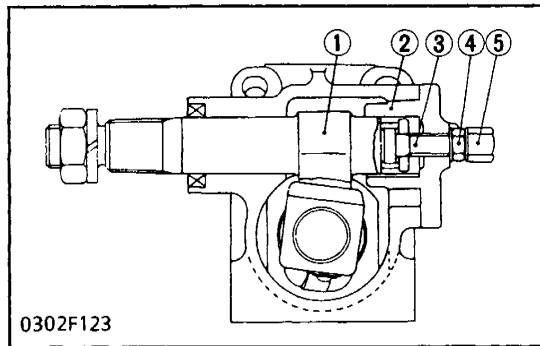

0302F123

Tightening torque	Side cover mounting screw	23.5 to 27.5 N·m 2.4 to 2.8 kgf·m 17.4 to 20.2 ft-lbs
-------------------	---------------------------	---

- (1) Sector Shaft
- (2) Side Cover
- (3) Adjusting Screw
- (4) Lock Nut
- (5) Cap Nut

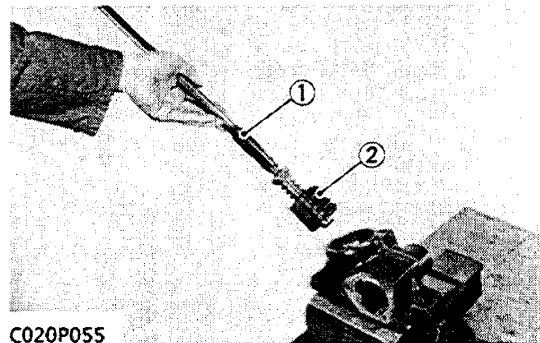

C020P055

Steering Column, Steering Shaft and Ball Nut Assembly

1. Remove the nut and steering column.
2. Remove the steering shaft (1) and ball nut assembly (2).

(When reassembling)

- Steering box assembly

 1. Install the sector shaft, and turn it clockwise fully.
 2. Install the ball nut assembly and mesh it with the sector gear, making sure that the thrust bearing does not leave the outer race.

- (1) Steering Shaft
- (2) Ball Nut Assembly

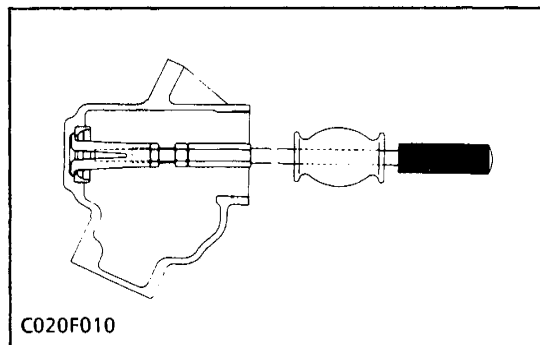

C020F010

Thrust Ball Bearing

1. Draw out the bearing outer with a bushing puller set (Code No.: 07916-51031).

SERVICING

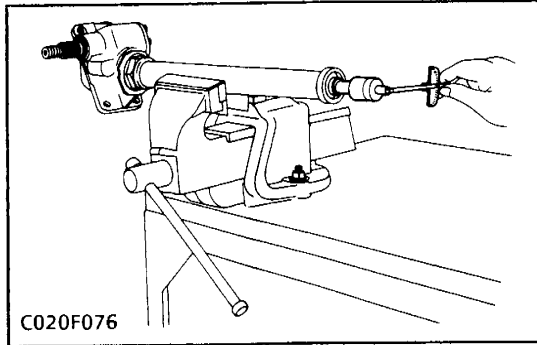

Steering Shaft Initial Turning Torque

1. Secure the steering assembly with a vise.
2. Set a torque wrench on the steering shaft, and measure the torque required initial turning.

Steering shaft initial turning torque	Factory spec.	Less than 1.72 N·m 0.175 kgf·m 1.27 ft-lbs
---------------------------------------	---------------	--

3. If the torque is not within the factory specifications, measure the torque again without the column bushing (4), oil seal (5) and sector shaft (1).

Initial turning torque (without bushing, seal and sector shaft)	Factory spec.	0.245 to 0.490 N·m 0.025 to 0.050 kgf·m 0.181 to 0.362 ft-lbs
---	---------------	---

4. If the torque is not within the factory specifications, adjust by turning the rear cover (3).

NOTE

- After adjustment, tighten the nut (2) to the specified torque (157 to 196 N·m, 16 to 20 kgf·m, 115.8 to 144.6 ft-lbs).

- (1) Sector Shaft
- (2) Nut
- (3) Rear Cover
- (4) Column Bushing
- (5) Oil Seal

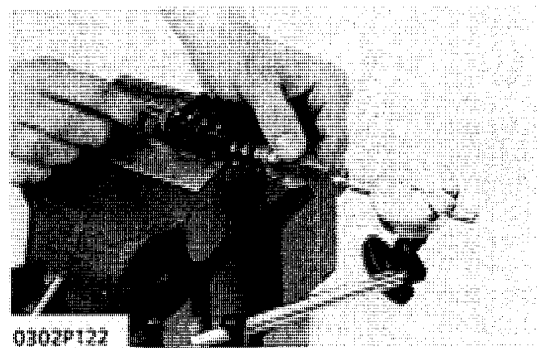
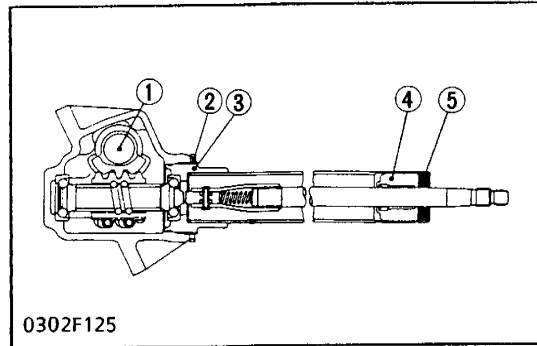
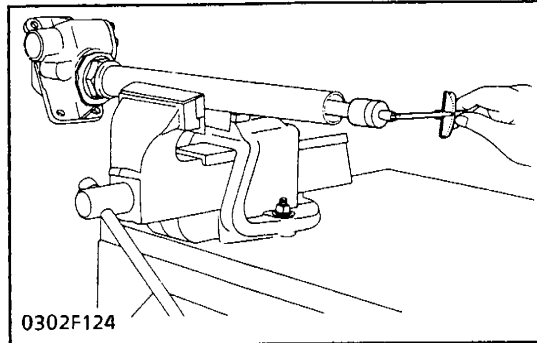

Axial Play of Ball Nut Assembly

1. Remove the ball nut assembly from the steering assembly.
2. Set the dial indicator.
3. Move the worm shaft in the axial direction by hand to measure the play.
4. If the play exceeds the allowable limit, replace.

NOTE

- Set the ball nut assembly horizontally.
- Check the worm shaft for smooth rotation by turning slowly, and replace the ball nut assembly if rotation is improper such as binding.

Axial play of ball nut assembly	Factory spec.	0.2 mm 0.008 in.
---------------------------------	---------------	---------------------

[2] POWER STEERING

[B1550-B1750-B1550HST-B1750HST]

This power steering is based on that of the domestic model (Saturn Tractor X-20, 24), but the following points have been modified; valve assembly, steering shaft, steering column assembly and pitman arm (namely steering wheel shaft connection.)

DISASSEMBLING AND ASSEMBLING

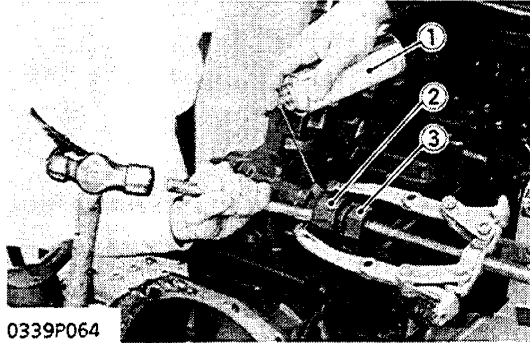

(1) Penetrating Oil (2) Pitman Arm (3) Nut

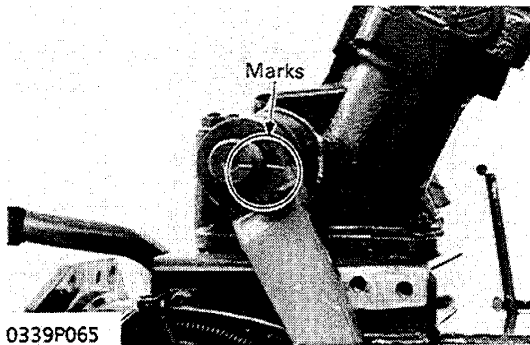

0339P065

Removing Meter Panel, Steering Wheel and Pipes

- See page S.5-8.

Pitman Arm

1. Loosen the nut (3) and remove the pitman arm (2) with a puller. If it is hard to remove, apply a penetrating oil (1) between pitman arm (2) and sector gear shaft and then strike the pitman arm (2) during pulling with the puller.
2. Remove the nut (3), spring washer and pitman arm from the sector gear shaft.

(When reassembling)

■ IMPORTANT

- Install the pitman arm to the sector gear shaft so that their marks align.

Tightening torque	Pitman arm mounting nut (3)	98.1 to 147.1 N·m 10.0 to 15.0 kgf·m 72.3 to 108.5 ft-lbs
-------------------	-----------------------------	---

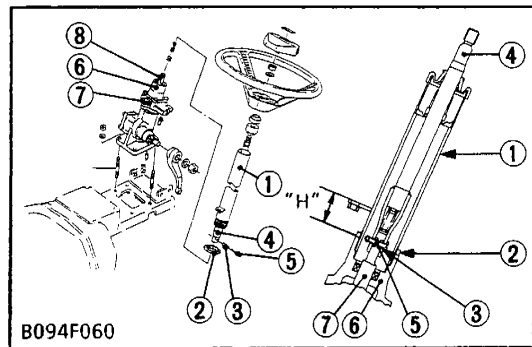

(1) Steering Column (2) Lock Nut (3) Spring Pin (4) Steering Shaft (5) Cotter Pin (6) Top Cover (7) Valve Assembly (8) Worm Shaft

Removing Steering Assembly

- See page S.5-9, 12.

Steering Column

1. Secure the steering assembly in a vise.
2. Turn the steering shaft several times to drain oil.
3. Loosen the lock nut (2) and unscrew the steering column (1) to remove it.

(When reassembling)

■ IMPORTANT

- Screw in the column (1) until the height "H" reaches 32.7 to 34.7 mm (1.29 to 1.37 in.), then lock it.

Tightening torque	Column lock nut (2)	98.1 to 127.5 N·m 10.0 to 13.0 kgf·m 72.3 to 94.0 ft-lbs
-------------------	---------------------	--

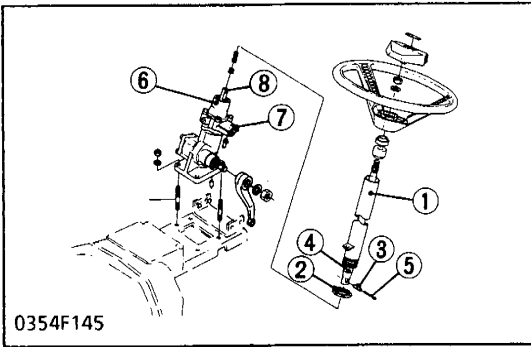

Steering Shaft and Top Cover

1. Remove the cotter pin (5) and spring pin (4) for separating the steering shaft (4) from the power steering assembly.
2. Remove the screws which secure the top cover (6), and remove the top cover.

(When reassembling)

Tightening torque	Top cover mounting screws	23.5 to 27.5 N·m 2.4 to 2.8 kgf·m 17.4 to 20.3 ft-lbs
-------------------	---------------------------	---

- | | |
|---------------------|--------------------|
| (1) Steering Column | (5) Cotter Pin |
| (2) Lock Nut | (6) Top Cover |
| (3) Spring Pin | (7) Valve Assembly |
| (4) Steering Shaft | (8) Worm Shaft |

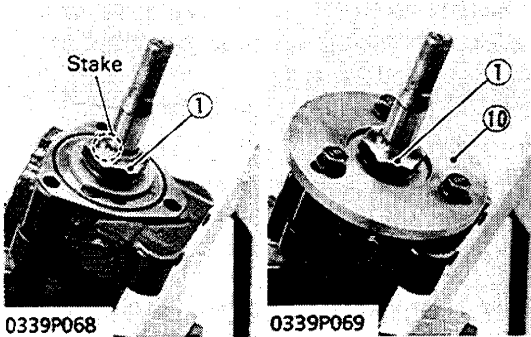

Valve Assembly

1. Mount the power steering valve holder (10) (Code No.: 07916-52891).
2. Put back the stakes of the nut (1), then remove the nut (1).
3. Remove the holder (10) and valve assembly. Set the worm shaft horizontally to remove each part easily.

(When reassembling)

■ IMPORTANT

- Lightly tighten the nut (1) by hand so that the axial play of the worm shaft is within the factory spec. while holding the worm shaft (9) with a wrench. Never tighten the nut (1) hardly. Stake the nut (1) with a pin punch.

Axial play of worm shaft	Factory spec	0 to 0.05 mm 0 to 0.0020 in.
--------------------------	--------------	---------------------------------

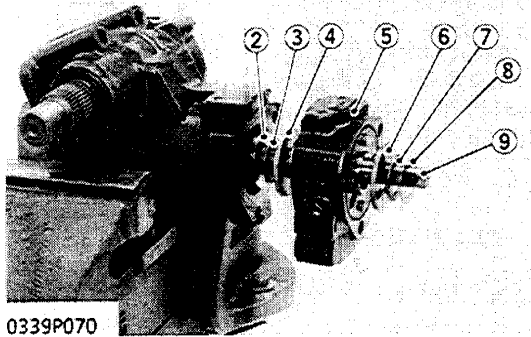

- | | |
|---------------------------|---------------------------|
| (1) Nut | (6) Thrust Race |
| (2) Thrust Race | (7) Thrust Needle Bearing |
| (3) Thrust Needle Bearing | (8) Thrust Race |
| (4) Thrust Race | (9) Worm Shaft |
| (5) Valve Housing | (10) Valve Holder |

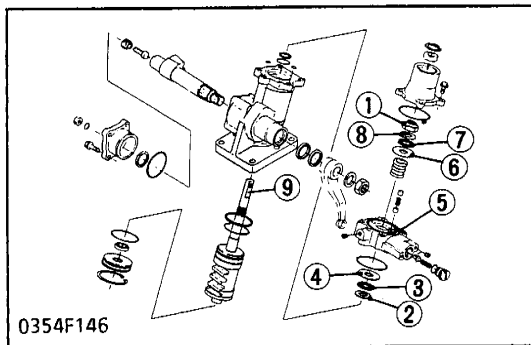

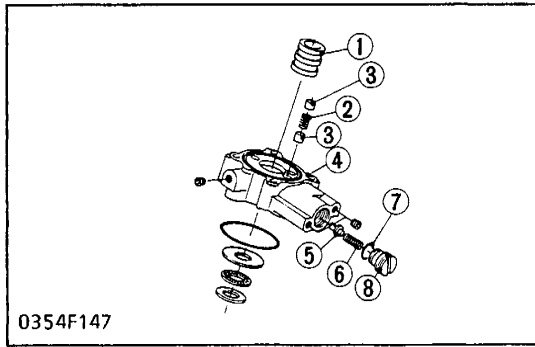

- (1) Spool
- (2) Centering Spring
- (3) Reaction Pistons
- (4) Valve Housing
- (5) Relief Valve Poppet
- (6) Relief Spring
- (7) O-ring
- (8) Adjusting Screw

Disassembling Valve Housing

■ IMPORTANT

- Do not disassemble the relief valve needlessly, since it has been factory-adjusted.

1. Remove the centering springs (2) and reaction pistons (3).
2. Remove the spool (1) and remember the direction of it against valve housing (4).
3. Remove the relief valve if needed.

(When reassembling)

- Apply grease to seals in the valve.
- When installing the spool (1), face the small chamfered side of the spool bore toward the "P" mark (top side) on the valve housing (4).

■ IMPORTANT

- If the relief valve is disassembled, after reassembly, be sure to adjust the setting pressure and stake the adjusting screw with a pin punch.
- When the valve housing (4) or spool (1) are damaged, replace them as a unit.

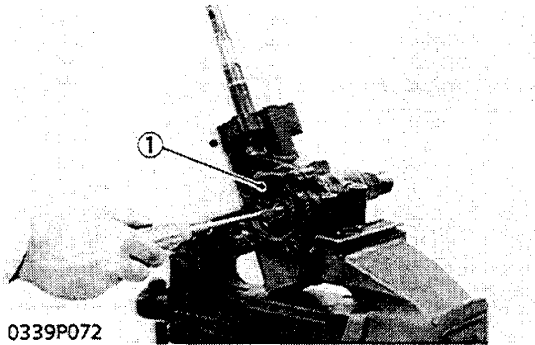

0339P072
(1) Side Cover

Side Cover

1. Put back the stakes of the lock nut and remove it on the adjusting screw.
2. Remove the side cover mounting screws.
3. Turn the adjusting screw clockwise to remove the side cover (1).

(When reassembling)

- Apply grease to the O-ring.
- Stake the lock nut with a pin punch.

Tightening torque	Lock nut	39.2 to 45.1 N·m 4.0 to 4.6 kgf·m 28.9 to 33.3 ft-lbs
	Side cover mounting screw	23.5 to 27.5 N·m 2.4 to 2.8 kgf·m 17.4 to 20.3 ft-lbs

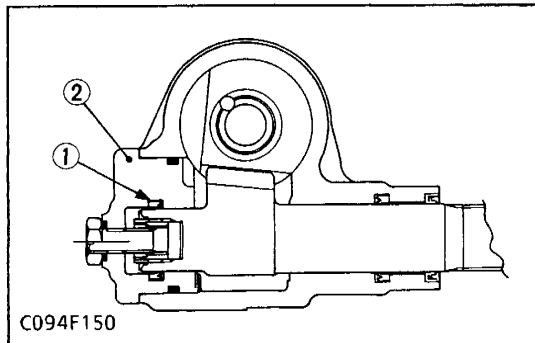

C094F150
(1) Oil Seal (2) Side Cover

Oil Seal on Side Cover

1. Remove the oil seal inside of the side cover.

(When reassembling)

- Apply grease to the ring groove, before mounting the oil seal on it.
- Direct the lip of the oil seal inward.

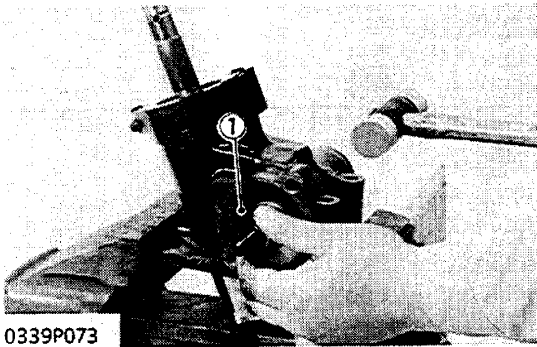

0339P073

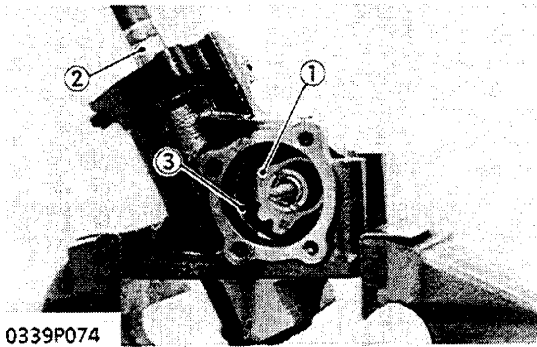

0339P074

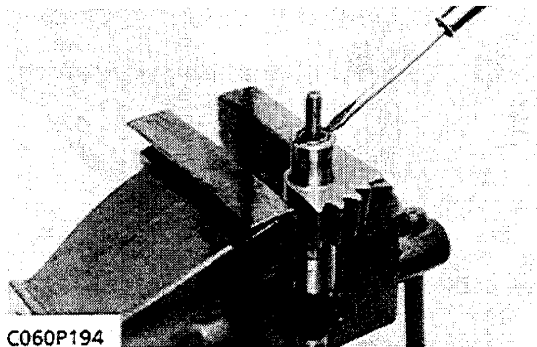

C060P194

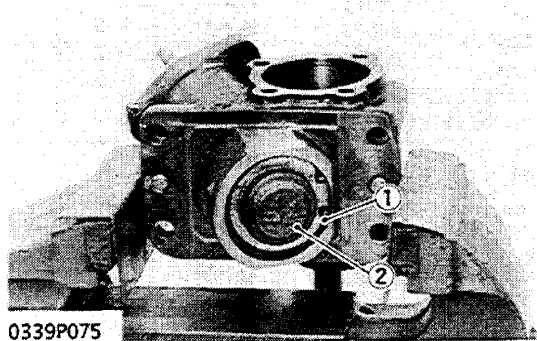

0339P075

(1) Snap Ring (2) End Cover

Sector Gear Shaft

1. Tap out the sector gear shaft (1) toward the side cover while holding the another end to avoid dropping.

(When reassembling)

- Turn the worm shaft (2) so that the ball nut (3) is centered in its travel.
Then, install the sector gear shaft (1) so that the center of its teeth engages the center of the teeth of the ball nut (3).

NOTE

- When setting the sector gear shaft (1), take care not to damage the oil seal and U-seal in the gear box.

- (1) Sector Gear Shaft
- (2) Worm Shaft
- (3) Ball Nut

Adjuster of Sector Gear Shaft

1. Remove the stakes and adjuster.

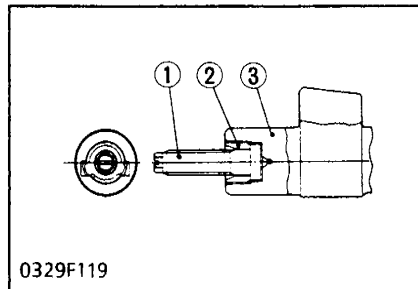

- (1) Adjusting Screw
- (2) Adjuster
- (3) Sector Gear Shaft

(When reassembling)

- Apply grease to the head of adjuster.
- Set the adjuster so that the axial play of the adjusting screw is within the factory spec.

Axial play of adjusting screw	Factory spec	0.03 to 0.05 mm 0.0012 to 0.0019 in.
-------------------------------	--------------	---

- Stake the adjuster with a pin punch.

Snap Ring

1. Remove the snap ring (1) which retains the end cover (2).

(When reassembling)

NOTE

- Direct the blunt edge side of the snap ring (1) to the end cover (2).

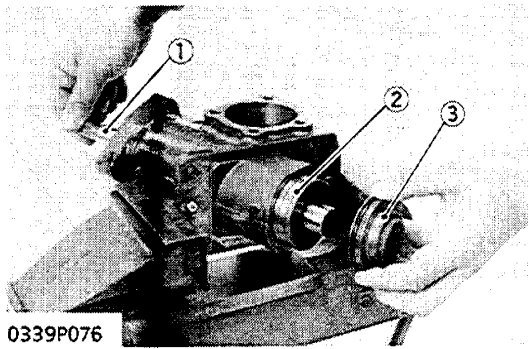

End Cover and Ball Nut Assembly

1. Tap out the worm shaft (1) toward the end cover (3) to remove it.
2. Remove the ball nut (2) and worm shaft (1) (ball nut assembly) as a unit.

NOTE

- When drawing out the ball nut assembly, take care not to damage the seal rings on the ball nut (2) and ball nut surface.
- Never disassemble the ball nut assembly.

- | | |
|----------------|---------------|
| (1) Worm Shaft | (3) End Cover |
| (2) Ball Nut | |

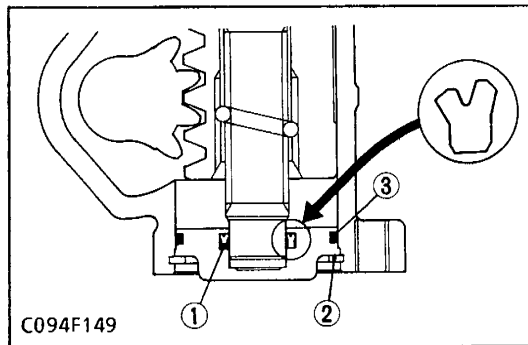

Seal Rings on End Cover

1. Remove the SR seal (1) and O-ring (3).

(When reassembling)

- Replace the SR seal (1) and O-ring (3) with new ones.
- Apply grease to the O-ring (3) and SR seal (1).
- Before setting them inside of the end cover and on it, apply grease to the ring grooves.

- | | |
|---------------|------------|
| (1) SR Seal | (3) O-ring |
| (2) Snap Ring | |

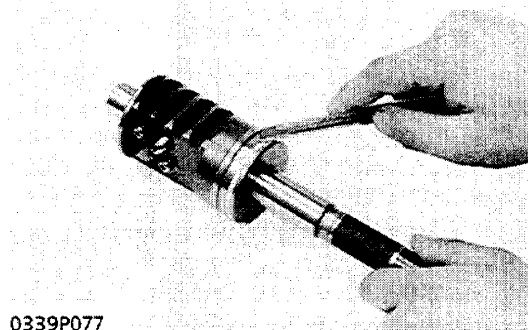

Seal Rings on Ball Nut

1. Cut the teflon ring with a knife and remove it.
2. Remove the O-ring inside the teflon ring.

(When reassembling)

- Apply grease to the ring groove.
- Replace the seal rings with new ones.
- Stretch the teflon ring by hand, install it on the ball nut, and press it so that it is restored to its original form.

- (1) Ball Nut

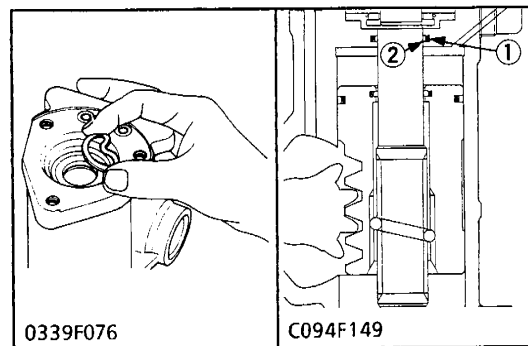

Seal Rings on Gear Box

1. Remove the seal ring (1).
2. Remove the seal ring (2).

(When reassembling)

- Apply grease to the ring groove.
- Replace the seal rings (1) (2) with new ones.
- Change the shape of the seal ring (1) to the heart figure by fingers, install it on the gear box and press it so that it is restored to its original form.

- | | |
|---------------|---------------|
| (1) Seal Ring | (2) Seal Ring |
|---------------|---------------|

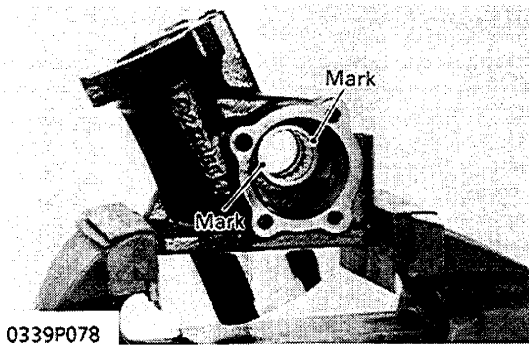

0339P078

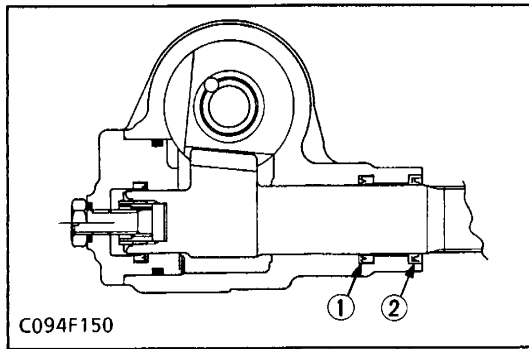

C094F150

Oil Seal, and Dust Seal on Gear Box

1. Remove the oil seal (1) with a sharp tool.
2. Remove the dust seal (2).

(When reassembling)

- Replace the oil seal (1) and dust seal (2) with new ones.
- Direct the lip of the dust seal (2) outward.
- Direct the lip of the oil seal (1) inward.
- After applying grease to the ring groove and to seals, set them.

(1) Oil Seal

(2) Dust Seal

SERVICING

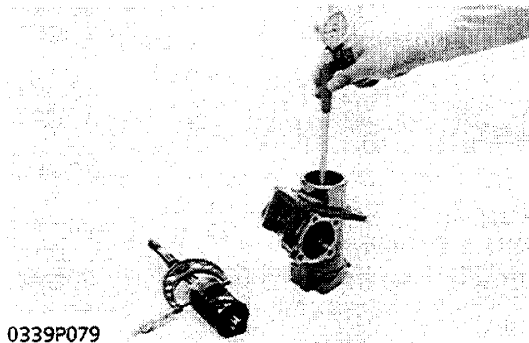

0339P079

Clearance between Steering Gear Box and Ball Nut

1. Measure the steering gear box cylinder I.D. with a cylinder gauge.
2. Measure the ball nut O.D. with an outside micrometer, and calculate this clearance.
3. If the clearance exceeds the allowable limit, replace the steering gear box or ball nut assembly.

Clearance between steering gear box and ball nut	Factory spec.	0.030 to 0.079 mm 0.00118 to 0.00311 in.
	Allowable limit	0.15 mm 0.0059 in.

Gear box bore I.D.	Factory spec.	56.00 to 56.030 mm 2.2047 to 2.20591 in.
--------------------	---------------	---

Ball nut O.D.	Factory spec.	54.951 to 54.970 mm 2.16343 to 2.16417 in.
---------------	---------------	---

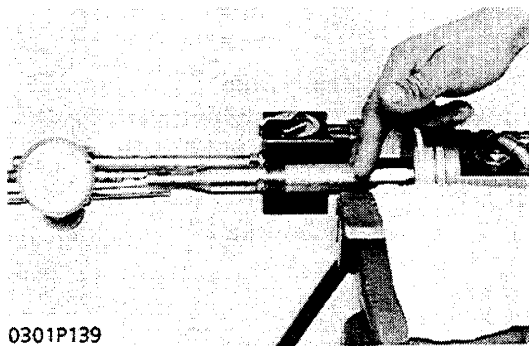

0301P139

Axial Play of Ball Nut Assembly

1. Secure the ball nut assembly in a vise.
2. Set a dial indicator with its finger on the worm shaft of the ball nut assembly.
3. Move the worm shaft axially and measure the play.
4. If the play exceeds the allowable limit, replace the ball nut assembly.

Axial play of ball nut assembly	Factory spec.	0 to 0.05 mm 0 to 0.0020 in.
	Allowable limit	0.100 mm 0.00394 in.

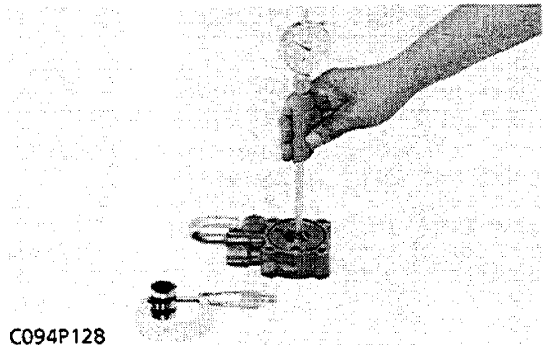

C094P128

Clearance between Valve Housing and Spool

1. Measure the valve housing I.D. with a cylinder gauge and the spool O.D. with an outside micrometer, and calculate this clearance.
2. If the clearance exceeds the allowable limit, replace the spool and valve housing as a unit.

IMPORTANT

- Check to see if the spool slides smoothly in the valve housing.

Clearance between valve housing and spool	Factory spec.	0.005 to 0.020 mm 0.00020 to 0.00079 in.
	Allowable limit	0.04 mm 0.0016 in.
Spool O.D.	Factory spec.	28.000 to 28.005 mm 1.10236 to 1.10256 in.
Valve housing I.D.	Factory spec.	28.010 to 28.020 mm 1.10276 to 1.10315 in.

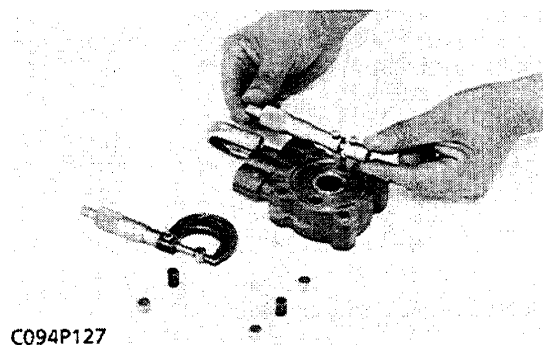

C094P127

Clearance between Valve Housing and Piston

Clearance between valve housing and piston	Factory spec.	0.005 to 0.030 mm 0.00020 to 0.00118 in.
	Allowable limit	0.06 mm 0.0024 in.
Piston O.D.	Factory spec.	9.990 to 10.005 mm 0.39331 to 0.39390 in.
Valve housing I.D.	Factory spec.	10.010 to 10.020 mm 0.39409 to 0.39449 in.

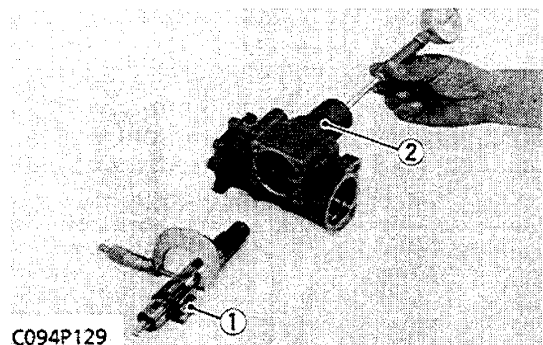

C094P129

(1) Section Gear Shaft (2) Steering Gear Box

Sector Gear Shaft

1. Measure the sector gear shaft O.D. (1) (steering gear box side, side cover side) with an outside micrometer.
2. If the measurement exceeds the allowable limit, replace the sector gear shaft.

Sector gear shaft O.D.	Steering gear box side	Factory spec.	27.997 to 28.000 mm 1.10224 to 1.10236 in.
		Allowable limit	27.900 mm 1.09843 in.
	Side cover side	Factory spec.	25.997 to 26.000 mm 1.02350 to 1.02362 in.
		Allowable limit	25.900 mm 1.01969 in.

Clearance between Steering Gear Box and Sector Gear Shaft

Clearance between steering gear box and sector gear shaft	Factory spec.	0.020 to 0.033 mm 0.00079 to 0.00130 in.
	Allowable limit	0.10 mm 0.0039 in.
Steering gear box I.D.	Factory spec.	28.020 to 28.030 mm 1.10315 to 1.10354 in.
Side cover I.D.	Factory spec.	26.020 to 26.030 mm 1.02441 to 1.02480 in.

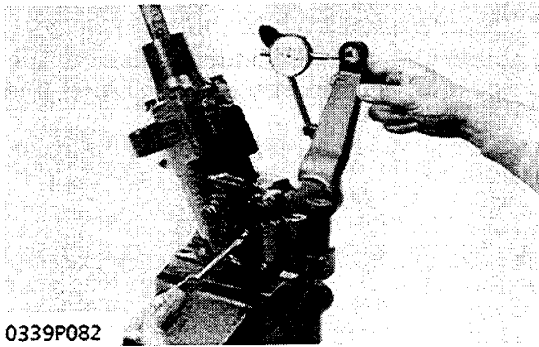

0339P082

Backlash between Sector Gear Shaft and Ball Nut

1. Attach the pitman arm having no play.
2. Set a dial indicator with its finger on the pitman arm.
3. Move the pitman arm lightly, and measure the deflection.
4. If the measurement is not within the factory specification, adjust the backlash with the adjusting screw.

Backlash between sector gear shaft and ball nut	Factory spec.	Less than	0.30 mm 0.0118 in.
---	---------------	-----------	-----------------------

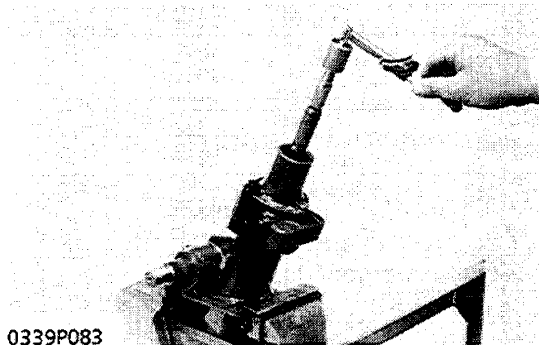

0339P083

Turning Torque of Worm Shaft

1. Set the torque wrench on the worm shaft and measure the torque required to initial turning.
2. If the measurement is not within the factory specification, disassemble the steering gear box.

Turning torque of worm shaft	Factory spec.	Less than	1.18 N·m 0.12 kgf·m 0.87 ft-lbs
------------------------------	---------------	-----------	---------------------------------------

[B2150-B2150HST]

This power steering is the same as that of B9200.

DISASSEMBLING AND ASSEMBLING

Removing Meter Panel, Steering Wheel and Pipes

- See page S.5-20.

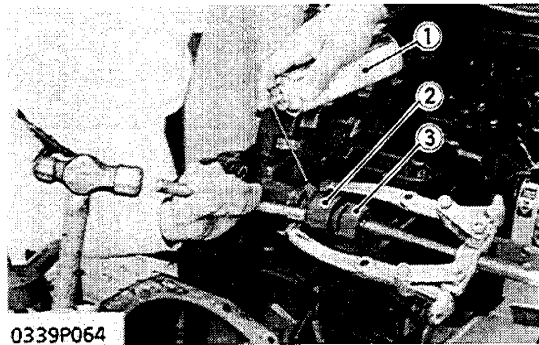

0339P064

Pitman Arm

1. Loosen the nut (3) and remove the pitman arm (2) with a puller. If it is hard to remove, apply a penetrating oil (1) between pitman arm (2) and sector gear shaft and then strike the pitman arm (2) during pulling with the puller.
2. Remove the nut (3), spring washer and pitman arm from the sector gear shaft.

(When reassembling)

■ IMPORTANT

- Install the pitman arm to the sector gear shaft so that their marks align.

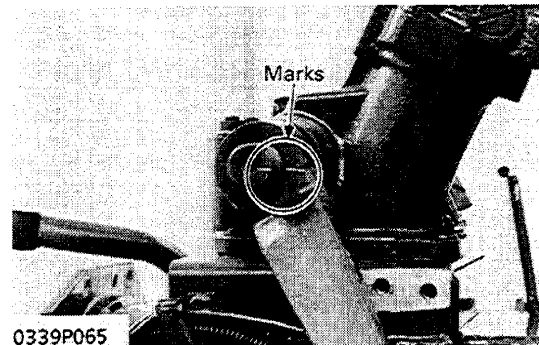

0339P065

Tightening torque	Pitman arm mounting nut (3)	176.5 to 235.4 N·m 18.0 to 24.0 kgf·m 130.2 to 173.6 ft-lbs
-------------------	-----------------------------	---

- (1) Penetrating Oil
- (2) Pitman Arm
- (3) Nut

Removing Steering Assembly

- See page S.5-21, 27.

Steering Column

1. Secure the steering assembly in a vise.
2. Turn the steering shaft several times to drain oil.
3. Loosen the lock nut (2) and unscrew the steering column (1) to remove it.

(When reassembling)

■ **IMPORTANT**

- Screw in the column (1) until the height "H" reaches 61 to 65 mm (2.40 to 2.56 in.), then lock it.

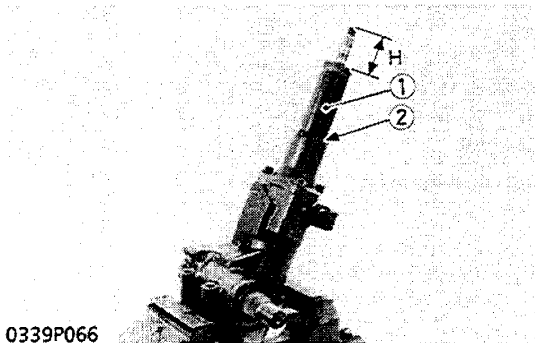

0339P066

(1) Steering Column (2) Lock Nut

Tightening torque	Column lock nut (2)	98.1 to 127.5 N·m 10.0 to 13.0 kgf·m 72.3 to 94.0 ft·lbs
-------------------	---------------------	--

Steering Shaft and Top Cover

1. Remove the rivet (3) and tap out the spring pin (2) connecting the steering shaft (1) to worm shaft. Pull up the steering shaft (1).
2. Remove the screws securing the top cover (4). Remove the top cover (4).

(When reassembling)

Tightening torque	Top cover mounting screws	37.3 to 56.9 N·m 3.8 to 5.8 kgf·m 27.5 to 42.0 ft·lbs
-------------------	---------------------------	---

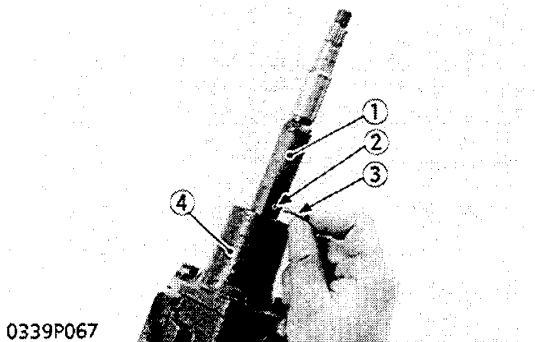

0339P067

(1) Steering Shaft (2) Spring Pin (3) Rivet (4) Top Cover

Valve Assembly

1. Mount the power steering valve holder (2) (Code No.: 07916-52891).
2. Put back the stake of the nut (1), then remove the nut (1).
3. Remove the holder (2) and valve assembly. Set the worm shaft horizontally to remove each part easily.

(When reassembling)

■ **IMPORTANT**

- Lightly tighten the nut (1) by hand while holding the worm shaft (10) with a wrench. Never tighten the nut (1) hardly. Stake the nut (1) with a pin punch.

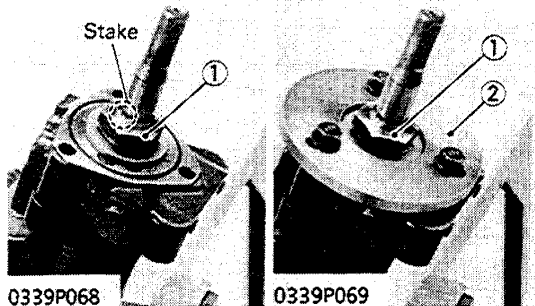

0339P068

0339P069

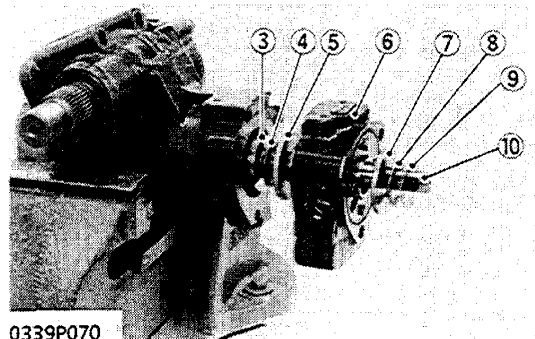

0339P070

- | | |
|---------------------------|---------------------------|
| (1) Nut | (6) Valve Housing |
| (2) Valve Holder | (7) Thrust Race |
| (3) Thrust Race | (8) Thrust Needle Bearing |
| (4) Thrust Needle Bearing | (9) Thrust Race |
| (5) Thrust Race | (10) Worm Shaft |

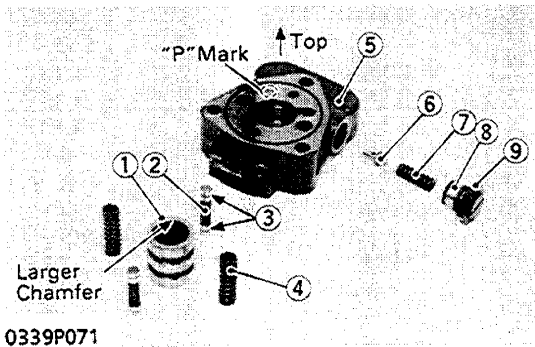

0339P071

- (1) Spool
- (2) Centering Spring
- (3) Reaction Pistons
- (4) Centering Spring
- (5) Valve Housing
- (6) Relief Valve Poppet
- (7) Relief Spring
- (8) Adjusting Screw
- (9) Lock Nut

Disassembling Valve Housing

IMPORTANT

- Do not disassemble the relief valve needlessly, since it has been factory-adjusted.

1. Remove the centering springs (2) (4) and reaction pistons (3).
2. Remove the spool (1) and remember the direction of it against valve housing (5).
3. Remove the relief valve if needed.

(When reassembling)

- Apply grease to seals in the valve.
- When installing the spool (1), face the small chamfered side of the spool bore toward the "P" mark (top side) on the valve housing (5).

IMPORTANT

- If the relief valve is disassembled, after reassembly, be sure to adjust the setting pressure.
- When the valve housing (5) or spool (1) are damaged, replace them as a unit.

Tightening torque	Relief valve lock nut (9)	49.0 to 78.5 N·m 5.0 to 8.0 kgf·m 36.2 to 57.9 ft-lbs
-------------------	---------------------------	---

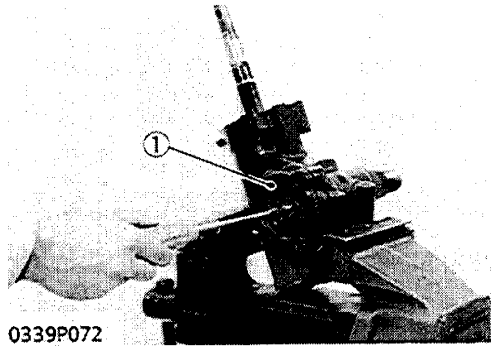

0339P072

- (1) Side Cover

Side Cover

1. Remove the cap nut, copper gaskets and lock nut on the adjusting screw.
2. Remove the side cover mounting screws.
3. Turn the adjusting screw clockwise to remove the side cover (1).

(When reassembling)

- Apply grease to the O-ring.

Tightening torque	Lock nut and cap nut	19.6 to 29.4 N·m 2.0 to 3.0 kgf·m 14.5 to 21.7 ft-lbs
	Side cover mounting screw	37.3 to 56.9 N·m 3.8 to 5.8 kgf·m 27.5 to 42.0 ft-lbs

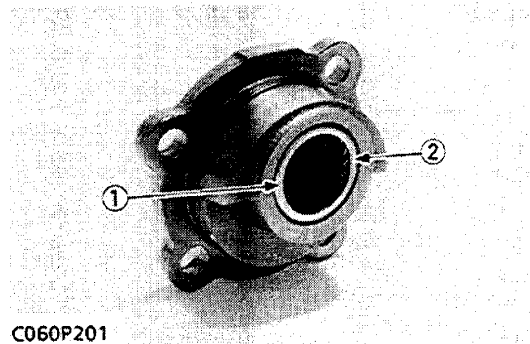

C060P201

- (1) Type Mark
- (2) Manufacturer's Mark

Needle Bearing on Side Cover

IMPORTANT

- Do not remove the needle bearing except when it needs replacing.

(When reassembling)

- Install the needle bearing so that manufacturer's mark and type mark face to the gear box.
- Press-fit the needle bearing so that it flushes with the side cover boss end.

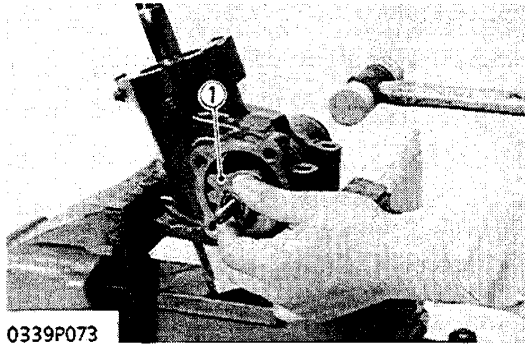

Sector Gear Shaft

1. Tap out the sector gear shaft (1) toward the side cover while holding the other end to avoid dropping.

(When reassembling)

- Turn the worm shaft (2) so that the ball nut (3) is centered in its travel.
Then, install the sector gear shaft (1) so that the center of its teeth engages the center of the teeth of the ball nut (3).

NOTE

- When setting the sector gear shaft (1), take care not to damage the oil seal and U-seal in the gear box.

- (1) Sector Gear Shaft
(2) Worm Shaft

- (3) Ball Nut

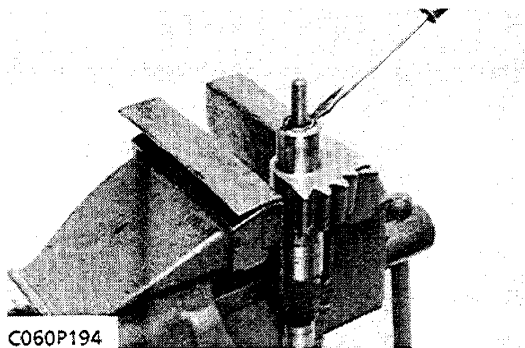
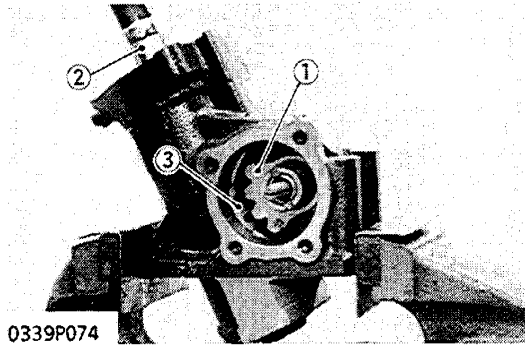

Adjuster of Sector Gear Shaft

1. Remove the stake and adjuster.

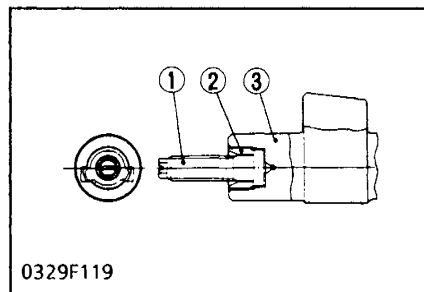

- (1) Adjusting Screw
(2) Adjuster
(3) Sector Gear Shaft

(When reassembling)

- Apply grease to the head of adjuster.

Snap Ring

1. Remove the snap ring (1) which retains the end cover (2).

(When reassembling)

NOTE

- Direct the blunt edge side of the snap ring (1) to the end cover (2).

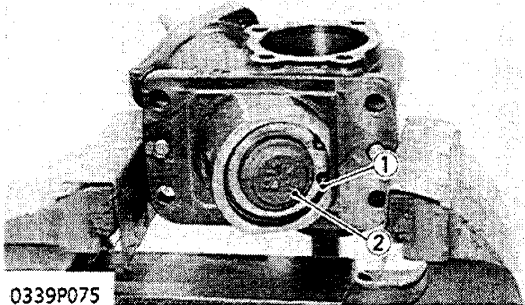

- (1) Snap Ring

- (2) End Cover

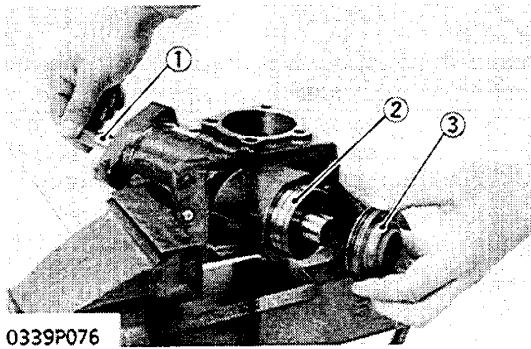

0339P076

End Cover and Ball Nut Assembly

1. Tap out the worm shaft (1) toward the end cover (3) to remove the end cover (3).
2. Remove the ball nut (2) and worm shaft (1) (ball nut assembly) as a unit.

NOTE

- When drawing out the ball nut assembly, take care not to damage the seal rings on the ball nut (2) and ball nut surface.
- Never disassemble the ball nut assembly.

- | | |
|----------------|---------------|
| (1) Worm Shaft | (3) End Cover |
| (2) Ball Nut | |

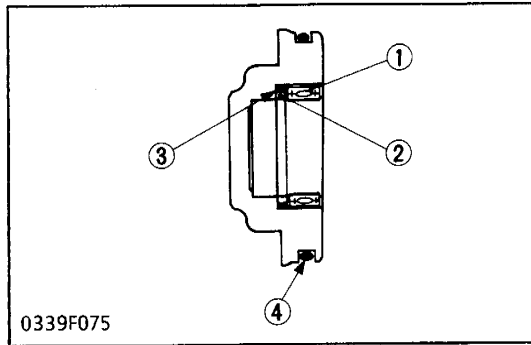

0339F075

Seal Rings and Needle Bearing on End Cover

1. Remove the teflon ring (2) and O-rings (3) (4).
2. Remove the needle bearing (1).

(When reassembling)

- Replace the teflon ring (2), O-rings (3) (4) and needle bearing with new ones.
- Apply grease to the O-ring (4).
- Install the needle bearing (1) so that the manufacturer's mark and type mark face to the top.
- Press fit the needle bearing (1) until its race surface is flush with the end cover surface.

- | | |
|--------------------|------------|
| (1) Needle Bearing | (3) O-ring |
| (2) Teflon Ring | (4) O-ring |

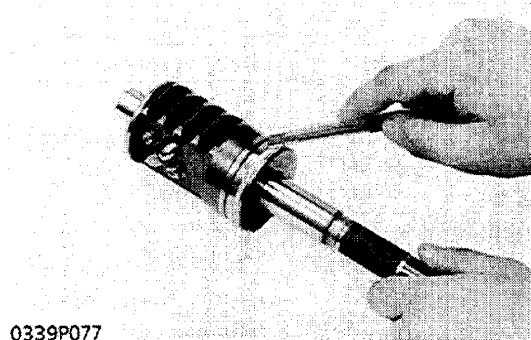

0339P077

Seal Rings on Ball Nut

1. Cut the teflon ring with a knife and remove it.
2. Remove the O-ring inside the teflon ring.

(When reassembling)

- Apply grease to the ring groove.
- Replace the seal rings with new ones.
- Stretch the teflon ring by hand, install it on the ball nut, and press it so that it is restored to its original form.

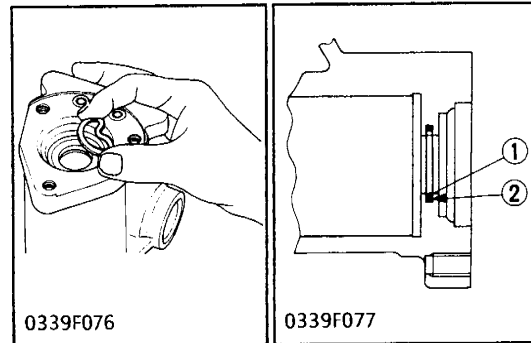

0339F076

0339F077

Seal Rings on Gear Box

1. Cut the teflon ring (1) with a knife and remove it.
2. Remove the O-ring (2).

(When reassembling)

- Apply grease to the ring groove.
- Replace the seal rings (1) (2) with new ones.
- Change the shape of the teflon ring (1) to the heart figure by fingers, install it on the gear box and press it so that it is restored to its original form.

- | | |
|-----------------|------------|
| (1) Teflon Ring | (2) O-ring |
|-----------------|------------|

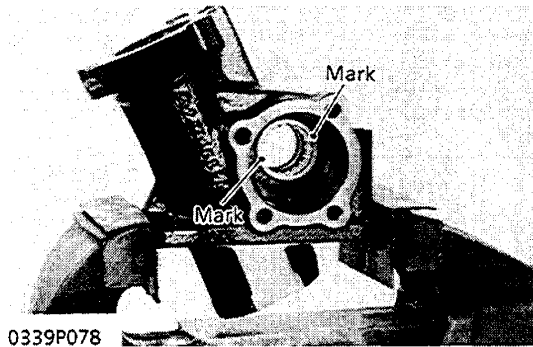

0339P078

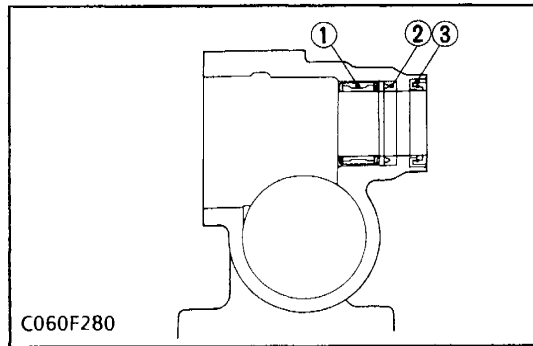

C060F280

Oil Seal, U-seal and Needle Bearing on Gear Box

1. Remove the oil seal (3).
2. Remove the U-seal (2) with a sharp tool.
3. Remove the needle bearing (1).

(When reassembling)

- Replace the oil seal (3), U-seal (2) and needle bearing (1) with new ones.
- Direct the lip of the oil seal (3) outward.
- Install the needle bearing (1) so that the manufacturer's mark and type mark face to the inside of the gear box. Press fit it until its race surface is flush with inside surface of gear box.

(1) Needle Bearing
(2) U-seal

(3) Oil Seal

SERVICING

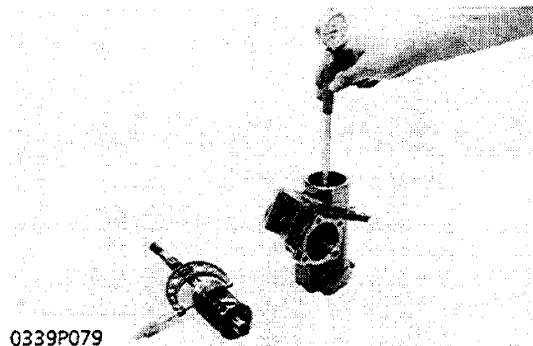

0339P079

Clearance between Steering Gear Box and Ball Nut

1. Measure the steering gear box cylinder I.D. with a cylinder gauge.
2. Measure the ball nut O.D. with an outside micrometer, and calculate the clearance.
3. If the clearance exceeds the allowable limit, replace the steering gear box or ball nut assembly.

Clearance between steering gear box and ball nut	Factory spec.	0.030 to 0.079 mm 0.00118 to 0.00311 in.
	Allowable limit	0.15 mm 0.0059 in.

Gear box bore I.D.	Factory spec.	61.000 to 61.030 mm 2.40158 to 2.40276 in.
Ball nut O.D.	Factory spec.	60.951 to 60.970 mm 2.39965 to 2.40040 in.

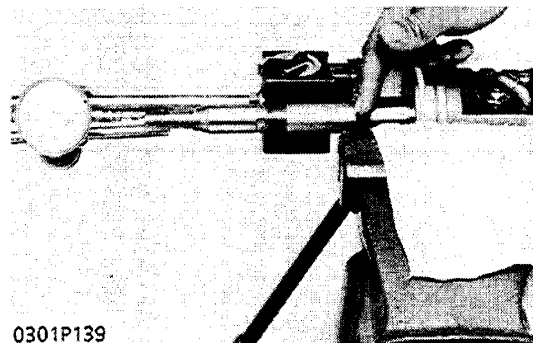

0301P139

Axial Play of Ball Nut Assembly

1. Secure the ball nut assembly in a vise.
2. Set a dial indicator with its finger on the worm shaft of the ball nut assembly.
3. Move the worm shaft axially and measure the play.
4. If the play exceeds the allowable limit, replace the ball nut assembly.

Axial play of ball nut assembly	Factory spec.	0 to 0.020 mm 0 to 0.00079 in.
	Allowable limit	0.100 mm 0.00394 in.

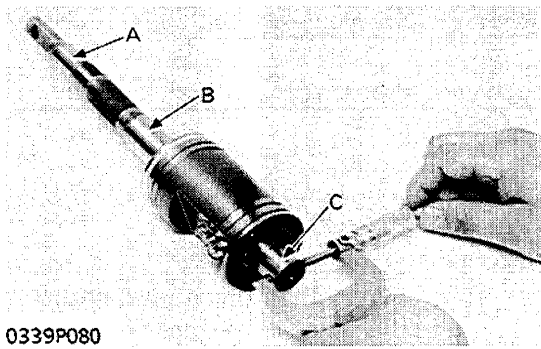

0339P080

Worm Shaft Wear

1. Measure the worm shaft O.D. with an outside micrometer.
2. If the measurement is less than the allowable limit, replace the ball nut assembly.

Worm shaft O.D.	A	Factory spec.	19.996 to 20.009 mm 0.78724 to 0.78776 in.
		Allowable limit	19.900 mm 0.78346 in.
	B	Factory spec.	24.996 to 25.009 mm 0.98410 to 0.98461 in.
		Allowable limit	24.900 mm 0.98031 in.
	C	Factory spec.	24.996 to 25.009 mm 0.98410 to 0.98461 in.
		Allowable limit	24.900 mm 0.98031 in.

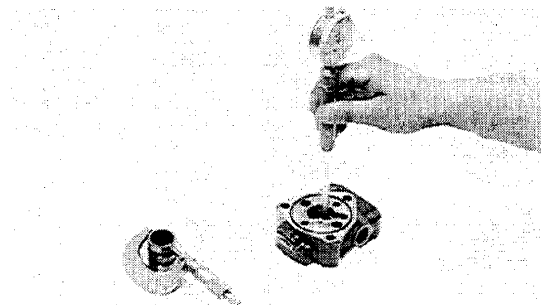

0339P081

Clearance between Valve Housing and Spool

1. Measure the valve housing I.D. with a cylinder gauge.
2. Measure the spool O.D. with an outside micrometer, and calculate the clearance.
3. If the clearance exceeds the allowable limit, replace the spool and valve housing as a unit.

■ IMPORTANT

- Check to see if the spool slides smoothly in the valve housing.

Clearance between valve housing and spool	Factory spec.	0.008 to 0.015 mm 0.00031 to 0.00059 in.
	Allowable limit	0.025 mm 0.00098 in.

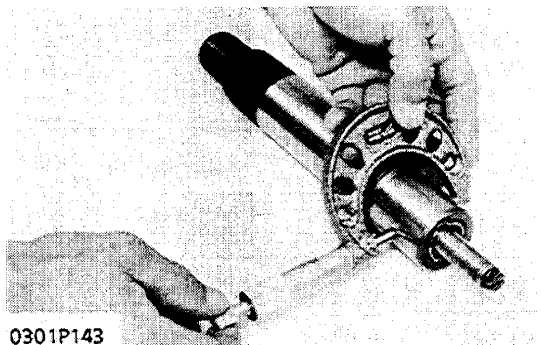

0301P143

Sector Gear Shaft

1. Measure the sector gear shaft O.D.s (steering gear box side, side cover side) with an outside micrometer.
2. If the measurement exceeds the allowable limit, replace the sector gear shaft.

Sector gear shaft O.D.	Steering gear box side	Factory spec.	34.957 to 35.000 mm 1.37626 to 1.37795 in.
		Allowable limit	34.900 mm 1.37402 in.
	Side cover side	Factory spec.	27.987 to 28.000 mm 1.10185 to 1.10236 in.
		Allowable limit	27.900 mm 1.09843 in.

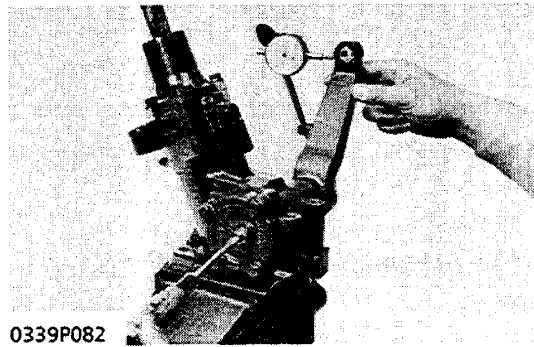

0339P082

Backlash between Sector Gear Shaft and Ball Nut

1. Attach the pitman arm having no play.
2. Set a dial indicator with its finger on the pitman arm.
3. Move the pitman arm lightly, and measure the deflection.
4. If the measurement is not within the factory specification, adjust the backlash with the adjusting screw.

Backlash between sector gear shaft and ball nut	Factory spec.	Less than	0.30 mm 0.0118 in.
---	---------------	-----------	-----------------------

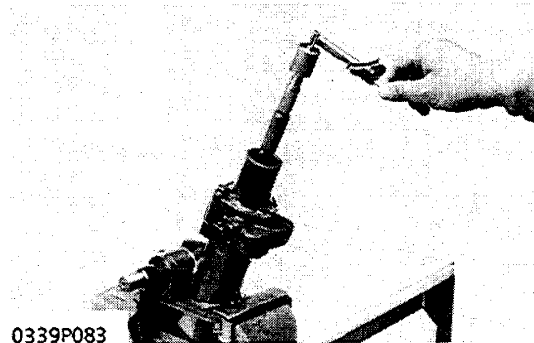

0339P083

Turning Torque of Worm Shaft

1. Set the torque wrench on the worm shaft and measure the torque required to initial turning.
2. If the measurement is not within the factory specification, disassemble the steering gear box.

Turning torque of worm shaft	Factory spec.	Less than	1.18 N·m 0.12 kgf·m 0.87 ft-lbs
------------------------------	---------------	-----------	---------------------------------------

CONTENTS

TROUBLESHOOTING	S.8-1
SERVICING SPECIFICATIONS	S.8-2
[B1550-B1750-B1550HST-B1750HST]	S.8-2
[B2150-B2150HST]	S.8-3
TIGHTENING TORQUES	S.8-4
[B1550-B1750-B1550HST-B1750HST]	S.8-4
[B2150-B2150HST]	S.8-5
CHECKING, DISASSEMBLING AND SERVICING	S.8-6
[1] HYDRAULIC PUMP	
CHECKING AND ADJUSTING	S.8-6
[B2150-B2150HST]	S.8-6
[B1550-B1750-B1550HST-B1750HST]	S.8-7
DISASSEMBLING AND ASSEMBLING	S.8-8
[B1550-B1750-B1550HST-B1750HST]	S.8-8
[B2150-B2150HST]	S.8-9
SERVICING	S.8-10
[2] CONTROL VALVE	
CHECKING AND ADJUSTING	S.8-11
DISASSEMBLING AND ASSEMBLING	S.8-12
[3] HYDRAULIC CYLINDER	
ADJUSTING	S.8-16
DISASSEMBLING AND ASSEMBLING	S.8-16
SERVICING	S.8-18
[4] HYDRAULIC BLOCK TYPE OUTLET	
CHECKING AND ADJUSTING	S.8-20
[B1550-B1750-B1550HST-B1750HST]	S.8-20
[B2150-B2150HST]	S.8-21
DISASSEMBLING AND ASSEMBLING	S.8-22
[B1550-B1750-B1550HST-B1750HST]	S.8-22
[B2150-B2150HST]	S.8-23

TROUBLESHOOTING

Symptom	Probable Cause	Solution	Reference Page
Implement Does Not Rise (No Noise) (Noise)	<ul style="list-style-type: none"> ● Control valve broken ● Control valve improperly adjusted ● Control valve improperly assembled ● Relief valve spring damaged ● Spool sticks ● Piston O-ring or cylinder damaged ● Oil strainer clogged ● Suction pipe loose or broken ● Suction pipe connecting hose looses or broken ● Suction pipe O-ring broken ● Insufficient transmission oil ● Relief valve setting pressure too low ● Hydraulic pump broken 	Replace Adjust Assemble Replace Repair Replace Clean or Replace Repair or Replace Repair or Replace Replace Refill Adjust or Replace Replace	S.8-11 S.8-14 S.8-12 S.8-11 S.8-14 S.8-16,17 S.G-7,8 — — — S.G-3 S.8-11 S.8-6,7
Implement Does Not Reach Maximum Height	<ul style="list-style-type: none"> ● Feedback rod improperly adjusted 	Adjust	S.8-12
Implement Does Not Lower	<ul style="list-style-type: none"> ● Control valve malfunctioning 	Repair or Replace	S.8-11
Implement Drops by Its Weight	<ul style="list-style-type: none"> ● Hydraulic cylinder worn or damaged ● Hydraulic cylinder cap O-ring broken ● Piston O-ring worn or damaged ● Control valve malfunctioning 	Replace Replace Replace Replace	S.8-18 S.8-16 S.8-17 S.8-11
Implement Hunts	<ul style="list-style-type: none"> ● Control valve improperly adjusted 	Adjust	S.8-14

SERVICING SPECIFICATIONS

[B1550-B1750-B1550HST-B1750HST]

Item		Factory Specification	Allowable Limit
Relief Valve of Control Valve	Setting Pressure	12.7 to 13.7 MPa 130 to 140 kgf/cm ² 1849 to 1991 psi	—
Relief Valve of Hydraulic Block Type Outlet	Setting Pressure	15.7 to 16.2 MPa 160 to 165 kgf/cm ² 2275 to 2347 psi	—
Hydraulic Cylinder	I.D.	65.06 to 65.10 mm 2.5614 to 2.5630 in.	65.15 mm 2.5650 in.
Rockshaft to Bushing	Clearance	0.075 to 0.114 mm 0.0030 to 0.0045 in.	0.30 mm 0.0118 in.
Rockshaft, Right	O.D.	34.925 to 34.950 mm 1.3750 to 1.3760 in.	—
Rockshaft, Left	O.D.	29.939 to 29.960 mm 1.1787 to 1.1795 in.	—
Bushing, Right	I.D.	35.025 to 35.039 mm 1.3789 to 1.3795 in.	—
Bushing, Left	I.D.	30.025 to 30.039 mm 1.1821 to 1.1826 in.	—
Piston Rod to Set Pin	Clearance	0.020 to 0.124 mm 0.0008 to 0.0048 in.	0.40 mm 0.0157 in.
Piston Rod	I.D.	15.03 to 15.15 mm 0.592 to 0.596 in.	—
Set Pin	O.D.	14.957 to 14.984 mm 0.5889 to 0.5899 in.	—
[Hydraulic Pump] Pump Delivery at Engine 2600 rpm, Oil Temperature 50°C, 122°F	at no pressure	21.3 ℓ / min. 5.6 U.S. GPM 4.7 Imp.GPM	—
	at 13.2 MPa 135 kgf / cm ² 1920 psi	21 ℓ / min. 5.5 U.S.GPM 4.6 Imp.GPM	17.5 ℓ / min. 4.6 U.S. GPM 3.9 Imp.GPM
Gear Shaft to Bushing	Clearance	0.045 to 0.071 mm 0.0018 to 0.0028 in.	0.12 mm 0.0047 in.
Gear Shaft	O.D.	13.989 to 14.000 mm 0.5507 to 0.5512 in.	—
Bushing	I.D.	14.045 to 14.060 mm 0.5530 to 0.5535 in.	—
Bushing	Length	15.99 to 16.00 mm 0.6295 to 0.6299 in.	15.90 mm 0.6260 in.
Gear to Casing	Clearance	—	0.15 mm 0.0059 in.

[B2150-B2150HST]

Item		Factory Specification	Allowable Limit
Relief Valve of Control Valve	Setting Pressure	13.2 to 13.7 MPa 135 to 140 kgf/cm ² 1920 to 1991 psi	—
Relief Valve of Hydraulic Block Type Outlet	Setting Pressure	14.7 to 15.2 MPa 150 to 155 kgf/cm ² 2133 to 2204 psi	—
Hydraulic Cylinder	I.D.	70.06 to 70.10 mm 2.7583 to 2.7598 in.	70.15 mm 2.7618 in.
Rockshaft to Bushing	Clearance	0.075 to 0.114 mm 0.0030 to 0.0045 in.	0.30 mm 0.0118 in.
Rockshaft, Right	O.D.	39.925 to 39.950 mm 1.5719 to 1.5728 in.	—
Rockshaft, Left	O.D.	34.925 to 34.950 mm 1.3750 to 1.3760 in.	—
Bushing, Right	I.D.	40.025 to 40.039 mm 1.5758 to 1.5763 in.	—
Bushing, Left	I.D.	35.025 to 35.039 mm 1.3789 to 1.3795 in.	—
Piston Rod to Set Pin	Clearance	0.020 to 0.124 mm 0.0008 to 0.0048 in.	0.40 mm 0.0157 in.
Piston Rod	I.D.	22.020 to 22.072 mm 0.8670 to 0.8689 in.	—
Set Pin	O.D.	21.948 to 22.000 mm 0.8641 to 0.8661 in.	—
[Hydraulic Pump] Pump Delivery at Engine 2600 rpm, Oil Temperature 50°C, 122°F	at no pressure	29 ℓ / min. 7.7 U.S. GPM 6.4 Imp.GPM	—
	at 13.2 MPa 135 kgf / cm ² 1920 psi	28 ℓ / min. 7.4 U.S.GPM 6.2 Imp.GPM	23 ℓ / min. 6.1 U.S. GPM 5.1 Imp.GPM
Gear Shaft to Bushing	Clearance	0.045 to 0.071 mm 0.0018 to 0.0028 in.	0.12 mm 0.0047 in.
Gear Shaft	O.D.	13.989 to 14.000 mm 0.5507 to 0.5512 in.	—
Bushing	I.D.	14.045 to 14.060 mm 0.5530 to 0.5535 in.	—
Bushing	Length	15.99 to 16.00 mm 0.6295 to 0.6299 in.	15.90 mm 0.6260 in.
Gear to Casing	Clearance	—	0.15 mm 0.0059 in.

TIGHTENING TORQUES

Tightening torques of screws and nuts on the table bellow is especially specified.
(For general use screws and nuts: See page S.G-4)

[B1550-B1750-B1550HST-B1750HST]

Item	N·m	kgf·m	ft-lbs
Hydraulic cylinder mounting screws and nuts	34.3 to 39.2	3.5 to 4.0	25.3 to 28.9
Cylinder cap mounting screws	60.8 to 106.8	6.2 to 10.9	44.8 to 78.8
Piston rod set pin mounting screw	23.6 to 27.4	2.4 to 2.8	17.4 to 20.2
Delivery pipe 1 eye joint bolt	53.9 to 68.6	5.5 to 7.0	39.8 to 50.6
Delivery pipe 2 eye joint bolt	53.9 to 68.6	5.5 to 7.0	39.8 to 50.6
Return pipe eye joint bolt	53.9 to 68.6	5.5 to 7.0	39.8 to 50.6
Oil filter cartridge	17.7 to 19.6	1.8 to 2.0	13.0 to 14.5
Oil strainer	98 to 137	10.0 to 14.0	72.4 to 101
Power steering delivery and return pipe end eye joint bolt	39.2 to 44.1	4.0 to 4.5	28.9 to 32.5
Charge pipe 1 eye joint bolt	53.9 to 68.6	5.5 to 7.0	39.8 to 50.6
Charge pipe 2 eye joint bolt	53.9 to 68.6	5.5 to 7.0	39.8 to 50.6
[Hydraulic Block Type Outlet]			
Relief valve assembly	49.0 to 58.8	5.0 to 6.0	36.2 to 43.4
Flow divider assembly	49.0 to 58.8	5.0 to 6.0	36.2 to 43.4
Hydraulic block type outlet eye joint bolt	68.6 to 88.2	7.0 to 9.0	50.6 to 65.1
[Control Valve]			
Control valve mounting screws	23.5 to 27.5	2.4 to 2.8	17.4 to 20.2
Cover mounting screws	7.8 to 11.7	0.8 to 1.2	5.8 to 8.7
Plug for unload valve 1	29.4 to 49.0	3.0 to 5.0	21.7 to 36.2
Plug 2 for check valve 2	39.2 to 58.8	4.0 to 6.0	28.9 to 43.4
Plug 1 for check valve 1	29.4 to 49.0	3.0 to 5.0	21.7 to 36.2

[B2150-B2150HST]

Item	N·m	kgf·m	ft-lbs
Hydraulic cylinder mounting screws and nuts	34.3 to 39.2	3.5 to 4.0	25.3 to 28.9
Cylinder cap mounting screws	34.3 to 39.2	3.5 to 4.0	25.3 to 28.9
Piston rod set pin mounting screw	48.1 to 55.9	4.9 to 5.7	35.4 to 41.2
Delivery pipe 1 eye joint bolt	53.9 to 68.6	5.5 to 7.0	39.8 to 50.6
Delivery pipe 2 eye joint bolt	53.9 to 68.6	5.5 to 7.0	39.8 to 50.6
Return pipe eye joint bolt	53.9 to 68.6	5.5 to 7.0	39.8 to 50.6
Oil filter cartridge	17.7 to 19.6	1.8 to 2.0	13.0 to 14.5
Oil strainer	53.9 to 68.6	5.5 to 7.0	39.8 to 50.6
Power steering delivery and return pipe end eye joint bolt	39.2 to 44.1	4.0 to 4.5	28.9 to 32.5
Charge pipe 1 eye joint bolt	53.9 to 68.6	5.5 to 7.0	39.8 to 50.6
Charge pipe 2 eye joint bolt	53.9 to 68.6	5.5 to 7.0	39.8 to 50.6
[Hydraulic Block Type Outlet]			
Relief valve assembly	49.0 to 58.8	5.0 to 6.0	36.2 to 43.4
Flow divider assembly	49.0 to 58.8	5.0 to 6.0	36.2 to 43.4
Hydraulic block type outlet mounting screw	17.7 to 19.7	1.8 to 2.1	13.0 to 14.5
[Control Valve]			
Control valve mounting screws	23.5 to 27.5	2.4 to 2.8	17.4 to 20.2
Cover mounting screws	7.8 to 11.7	0.8 to 1.2	5.8 to 8.7
Plug for unload valve 1	29.4 to 49.0	3.0 to 5.0	21.7 to 36.2
Plug 2 for check valve 2	39.2 to 58.8	4.0 to 6.0	28.9 to 43.4
Plug 1 for check valve 1	29.4 to 49.0	3.0 to 5.0	21.7 to 36.2

CHECKING, DISASSEMBLING AND SERVICING

[1] HYDRAULIC PUMP

CHECKING AND ADJUSTING

[B2150-B2150HST]

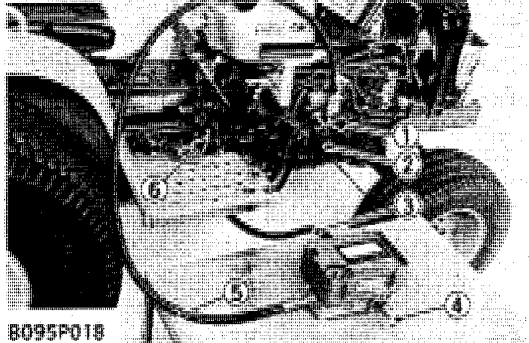

B095P018

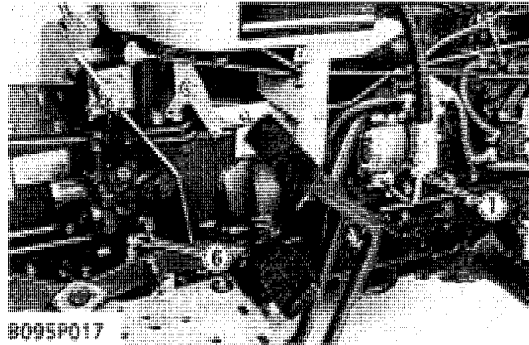

B095P017

Flowmeter Connecting and Test Preparation

■ IMPORTANT

- When using a flowmeter other than KUBOTA specified flowmeter (Code No.: 07916-52791), be sure to use the instructions with that flowmeter.
- In this hook-up, there is no relief valve. Therefore while testing, do not close the flowmeter loading valve completely.

1. Disconnect the delivery pipe (2).
2. Install the adaptor **61** (1) to the pump outlet port.
3. Install the adaptor **68** (6) to the hydraulic block type outlet as shown in the photo.

(Reference)

- Adaptors **61** and **68** are included in the adaptor set (Code No: 07916-54031).
4. Connect the hydraulic test hose (3) (Code No.: 07916-52651) to the adaptor **61** and flowmeter (Code No.: 07916 -52791) inlet port.
 5. Connect the another hydraulic test hose (5) to flowmeter outlet port and hydraulic block type outlet.
 6. Open the flowmeter loading valve (4) completely. (Turn counterclockwise)
 7. Start the engine and set the engine speed at 2600 rpm.
 8. Slowly close the loading valve to generate the pressure approx. 13.2 MPa (135 kgf/cm², 1920 psi). Hold in this condition until oil temperature reaches approx. 50°C (122°F).

- (1) Adaptor **61**
 (2) Delivery Pipe
 (3) Hose

- (4) Loading Valve
 (5) Hose
 (6) Adaptor **68** (PS 3/8")

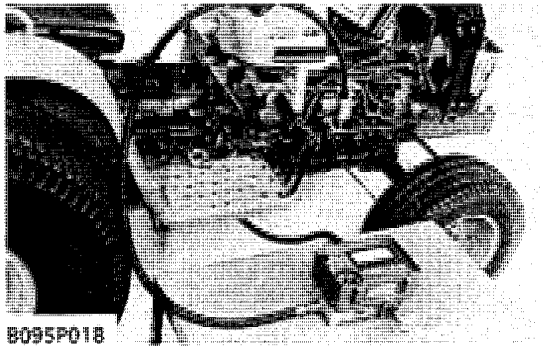

B095P018

Condition

- Engine speed ----- Approx. 2600 rpm
- Rated pressure ----- 13.2 MPa
135 kgf/cm²
1920 psi
- Oil temperature ----- 50 °C
122 °F

Pump Test

■ **NOTE**

- Before pump testing, perform the Flowmeter Connecting and Test Preparation. (See page S.8-6).

1. Open the loading valve completely.
2. Start the engine and set at approx. 2600 rpm.
3. Read and note the pump delivery at no pressure.
4. Slowly close the loading valve to increase pressure approx. 13.2 MPa (135 kgf/cm², 1920 psi).
5. Read and note the pump flow at rated pressure.
6. Open the loading valve and stop the engine.
7. If the pump delivery does not reach the allowable limit, check the pump suction line, oil filter or hydraulic pump.

Hydraulic pump delivery at no pressure	Factory spec.	Above 29 ℓ / min. 7.7 U.S. GPM 6.4 Imp. GPM
Hydraulic pump delivery at rated pressure	Factory spec.	Above 28 ℓ / min. 7.4 U.S. GPM 6.2 Imp. GPM
	Allowable limit	23 ℓ / min. 6.1 U.S. GPM 5.1 Imp. GPM

[B1550-B1750-B1550HST-B1750HST]

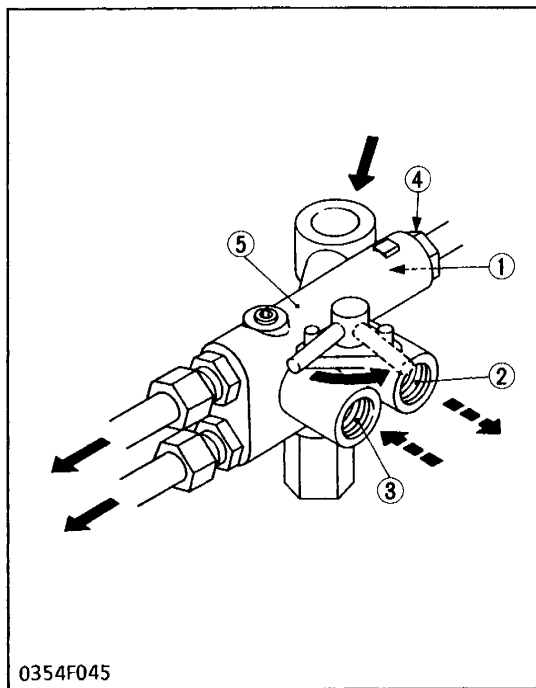

0354F045

- (1) Relief Valve
- (2) Outlet to Implements (PS 3/8")
- (3) Inlet from Implements (PS 3/8")
- (4) Hydraulic Block Type Outlet to Gear Pump
- (5) Hydraulic Block Type Outlet

Flowmeter Connection and Test Preparation

1. Close the hydraulic block type outlet (to gear pump) (4) with the plug (screw size: M20 Pitch 1.5 mm) after removing the relief valve (1).
2. Install two adaptor 68 to the outlet (to implements) (2) and the inlet (from implements) (3) after removing plugs.
3. Connect the hydraulic test hose to the adaptor 68 and flowmeter inlet port.
4. Connect another hydraulic test hose to flowmeter outlet port and hydraulic block type outlet.
5. Open the flowmeter loading valve completely. (Turn counterclockwise)
6. Start the engine and set the engine speed at 2600 rpm.
7. Slowly close the loading valve to generate the pressure approx. 13.2 MPa (135 kgf/cm², 1920 psi). Hold in this condition until oil temperature reaches approx. 50°C (122°F).

Hydraulic pump delivery at no pressure	Factory spec.	Above 21.3 ℓ / min. 5.6 U.S. GPM 4.7 Imp. GPM
Hydraulic pump delivery at rated pressure	Factory spec.	Above 21 ℓ / min. 5.5 U.S. GPM 4.6 Imp. GPM
	Allowable limit	17.5 ℓ / min. 4.6 U.S. GPM 3.9 Imp. GPM

DISASSEMBLING AND ASSEMBLING

[B1550-B1750-B1550HST-B1750HST]

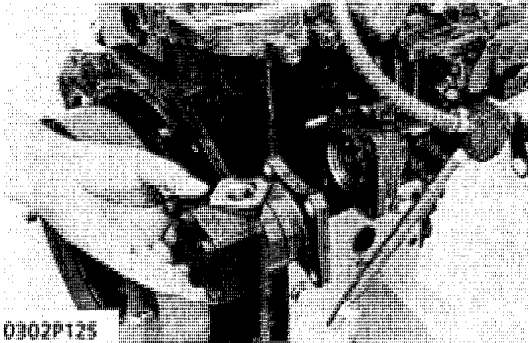

0302P125

Removing Gear Pump

1. Remove the gear pump mounting screws and separate the pump from the engine.

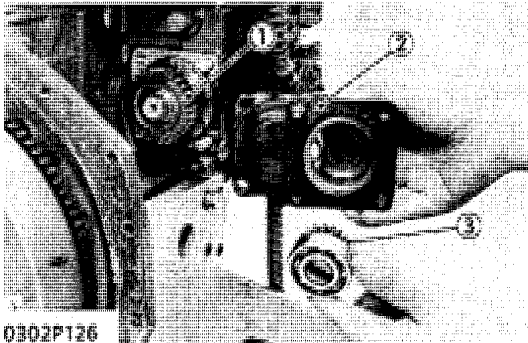

0302P126

Gear Pump Holder

1. Remove the gear pump holder mounting screws.
2. Remove the gear pump holder (2) with 20T gear (3).
3. Remove the external snap ring, and remove the 27T gear (1) and collar from the fuel cam shaft.

- (1) 27T Gear (3) 20T Gear
 (2) Gear Pump Holder

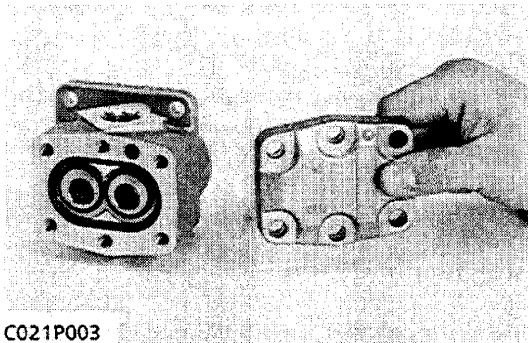

C021P003

End Cover

1. Secure the gear pump with a vise, and remove the end cover mounting screw.
2. Remove the end cover.

(When reassembling)

- Install the end cover to the casing, using care not to damage the O-ring.
- Align drain holes of the end cover and casing.

Tightening torque	End cover mounting screw	29.4 to 34.3 N·m 3.0 to 3.5 kgf·m 21.7 to 25.3 ft·lbs
-------------------	--------------------------	---

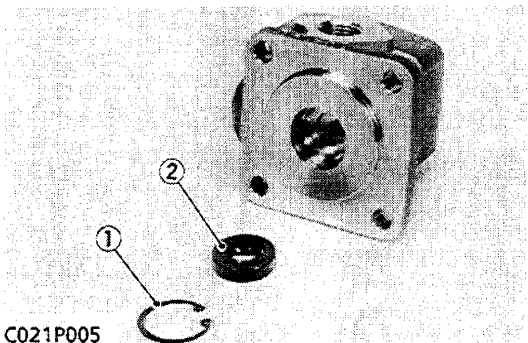

C021P005

Oil Seal

1. Remove the internal snap ring (1), and remove the oil seal (2).

(When reassembling)

- If the oil seal is defective, worn or scratched, replace it.

- (1) Snap Ring (2) Oil Seal

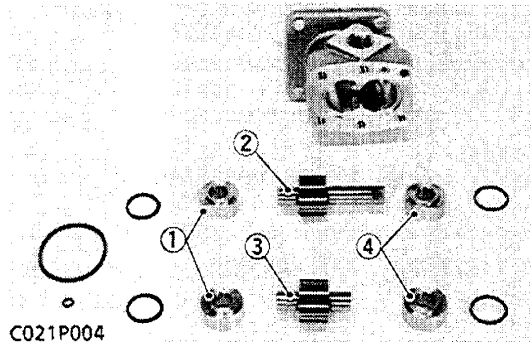

C021P004

Bushing and Gear

1. Push the drive gear shaft toward the end cover.
2. Remove the bushing (1) as a pair.
3. Remove the drive gear (2) and the driven gear (3).
4. Remove the bushing (4) as a pair.

(When reassembling)

- Install the bushing, noting its location and direction.
- Install the driven gear, noting its direction.

- | | |
|----------------|-----------------|
| (1) Bushing | (3) Driven Gear |
| (2) Drive Gear | (4) Bushing |

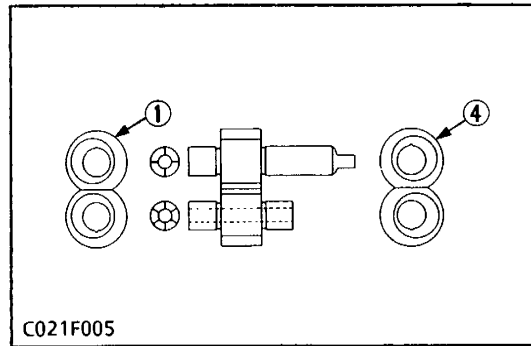

C021F005

[B2150-B2150HST]

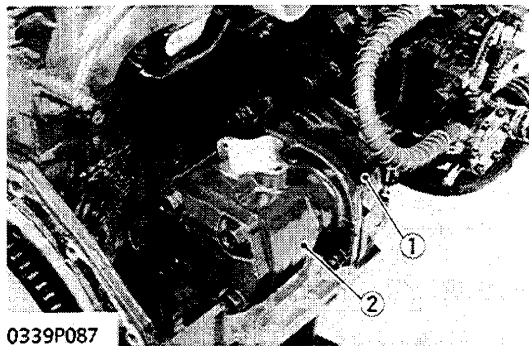

0339P087

Removing Gear Pump

1. Remove the gear pump holder (1) mounting screw and remove the gear pump holder with gear pump (2).
2. Separate the gear pump (2), gear pump holder (1) and 29T gear (4).

- | | |
|----------------------|--------------|
| (1) Gear Pump Holder | (3) Bearing |
| (2) Gear Pump | (4) 29T Gear |

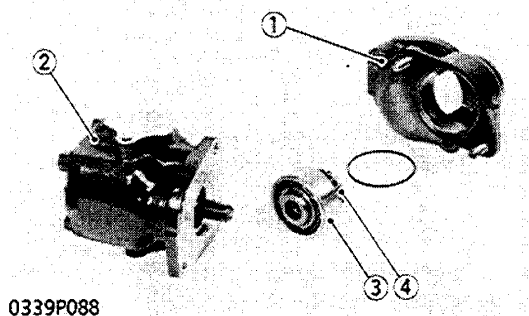

0339P088

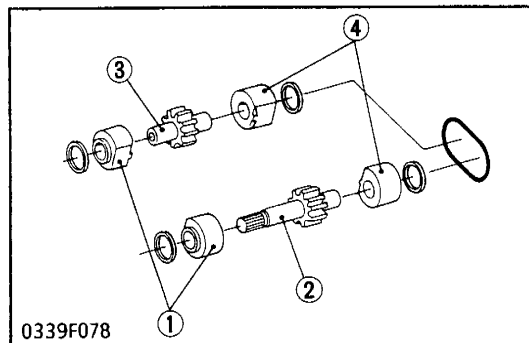

0339F078

Bushing and Gear

1. Push the drive gear shaft toward the end cover.
2. Remove the bushing (1), (4) as a pair.
3. Remove the drive gear (2) and the driven gear (3).

(When reassembling)

- Install the bushing, noting its location and direction.
- Install the driven gear, noting its direction.

- | | |
|----------------|-----------------|
| (1) Bushing | (3) Driven Gear |
| (2) Drive Gear | (4) Bushing |

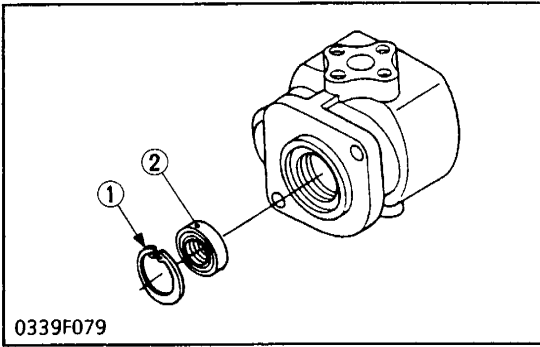

Oil Seal

1. Remove the internal snap ring (1) , and remove the oil seal (2).

(When reassembling)

- If the oil seal is defective, worn or scratched, replace.

- (1) Internal Snap Ring
- (2) Oil Seal

SERVICING

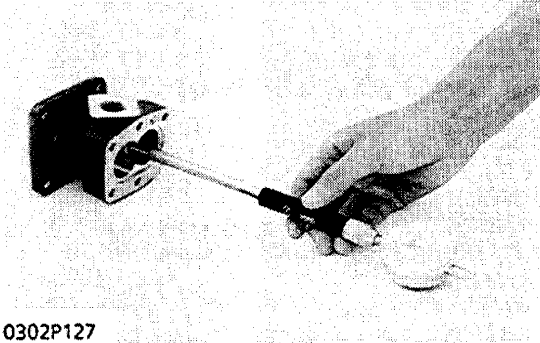

Clearance between Tip of Gear Tooth and Casing

1. Measure the gear O.D. with an outside micrometer.
2. Measure the casing I.D. with a cylinder gauge.
3. If the clearance exceeds the allowable limit, replace the assembly.

Clearance between tip of gear tooth and casing	Allowable limit	0.15 mm 0.0059 in.
--	-----------------	-----------------------

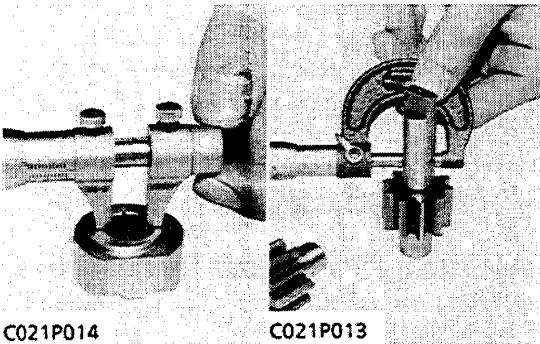

Clearance between Bushing and Shaft

1. Measure the shaft O.D. with an outside micrometer.
2. Measure the bushing I.D. with an inside micrometer.
3. If the clearance exceeds the allowable limit, replace.

Clearance between bushing and shaft	Factory spec.	0.045 to 0.071 mm 0.0018 to 0.0028 in.
	Allowable limit	0.12 mm 0.0047 in.

Shaft O.D.	Factory spec.	13.989 to 14.000 mm 0.5507 to 0.5512 in.
Bushing I.D.	Factory spec.	14.045 to 14.060 mm 0.5503 to 0.5535 in.

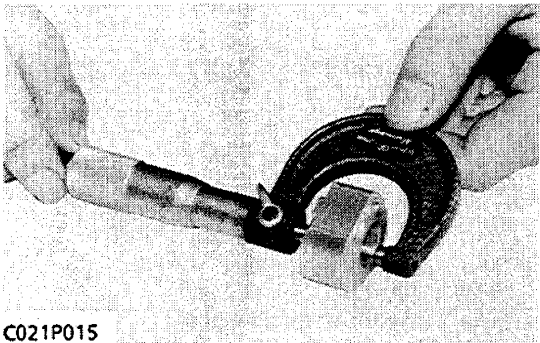

Bushing Length

1. Measure the bushing length with an outside micrometer.
2. If the length is less than the allowable limit, replace it.

Bushing length	Factory spec.	15.99 to 16.00 mm 0.6295 to 0.6299 in.
	Allowable limit	15.90 mm 0.6260 in.

[2] CONTROL VALVE

The control valve of B2150 is the same as that of B9200. The control valve of others is based on this.

CHECKING AND ADJUSTING

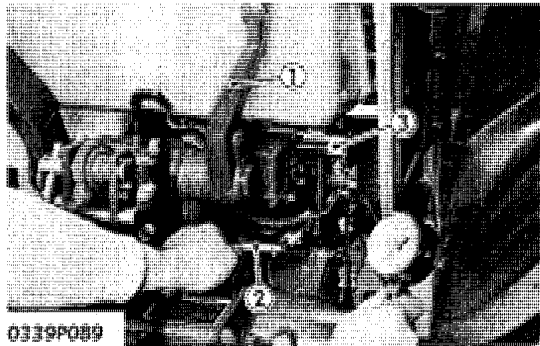

- 0339F089
- (1) Lift Arm RH
 - (2) Feedback Holder
 - (3) Adaptor E (Screw Size PS 3/8") (Included in the tester)

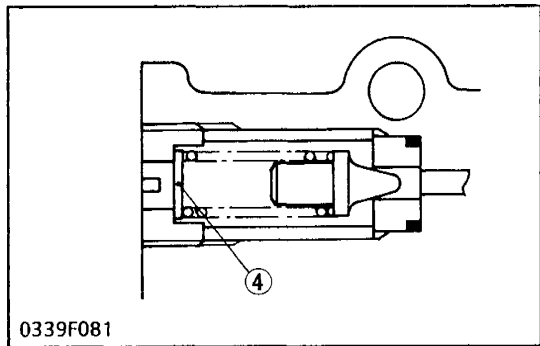

- 0339F081
- (4) Shim (Refer to (12) of Fig. 0339F024 in S.8-13)

Relief Valve Setting Pressure

1. Remove the feedback holder (2) from the lift arm (1).
2. Remove the joint bolt connecting the pipe and control valve. And install the adaptor E instead of the joint bolt. Then set the relief valve setting pressure tester (Code No.: 07916-50045).
3. Start the engine, warm it up, and then set the engine speed at the 2600 rpm.
4. Move the control lever to the "Lift" position, pull the feedback holder (2) to operate the relief valve and read the pressure gauge.
5. If the pressure is not within the factory specifications, adjust with the shim(4).

For disassembling, see page S.8-15.

Relief valve setting pressure	Allowable limit	B1550-B1750 B1550HST B1750HST	12.7 to 13.7 MPa 130 to 140 kgf/cm ² 1849 to 1991 psi
		B2150 B2150HST	13.2 to 13.7 MPa 135 to 140 kgf/cm ² 1920 to 1991 psi

(Reference)

- The relief pressure can be increased by adding shim (4) and decreased by removing shim (4).

Shim Code No.	Thickness	Pressure Variance
67156-3668-0	0.2 mm	690 kPa 7 kgf/cm ² 100 psi
67156-3666-0	0.3 mm	980 kPa 10 kgf/cm ² 142 psi
67156-3667-0	0.8 mm	2.65 MPa 27 kgf/cm ² 384 psi

DISASSEMBLING AND ASSEMBLING

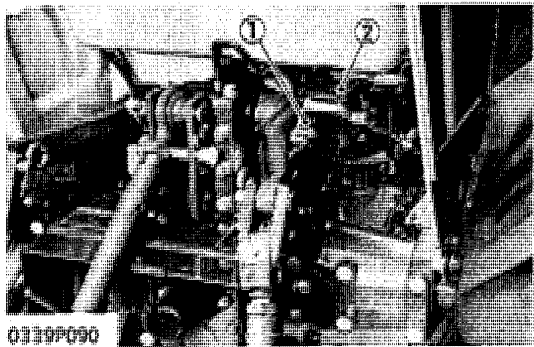

(1) Feedback Holder (2) Control Valve

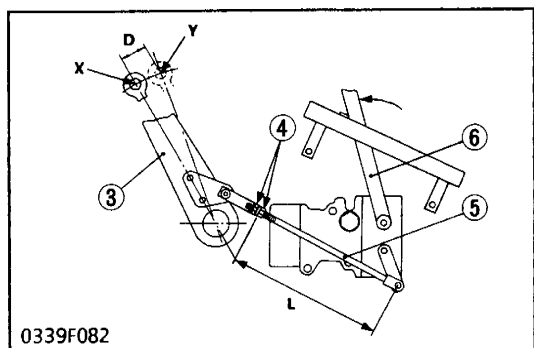

(3) Lift Arm (4) Adjusting Nut
(5) Feedback Rod (6) Control Lever

Removing Control Valve

1. Remove the joint bolts connecting the pipes to the control valve.
2. Remove the feedback holder mounting screws on the lift arm RH.
3. Remove the grip rubber from the control lever.
4. Remove the control valve mounting screws, and remove the control valve.

(When reassembling)

- Use care not to damage the O-ring.
- Tighten the feedback holder mounting screws after moving the feedback holder (1) to the direction of the smaller end of the lift arm (3).

Tightening torque	Control valve mounting screws	23.5 to 27.5 N·m 2.4 to 2.8 kgf·m 17.4 to 20.2 ft-lbs
	Pipe eye joint bolts	53.9 to 68.6 N·m 5.5 to 7.0 kgf·m 39.8 to 50.6 ft-lbs

■ IMPORTANT

- Adjust the feedback rod length to avoid damaging the differential case with the hydraulic arm.

- 1) Turn the nuts (4) so that the length "L" becomes to be the following.

	Length "L"
B1550.B1750 B1550HST B1750HST	180 mm, 7.1 in.
B2150 B2150HST	208 mm, 8.2 in.

- 2) Start the engine and move the control lever to the rear end. At this time, the lift arm is lifted to max. height (X).
- 3) Then move the lift arm (3) to the upper end (Y) by hand and measure the play "D".
If the play "D" is not between 10 mm and 20 mm (0.4 in. and 0.8 in.), adjust with the nuts (4) so that the play "D" becomes between 10 mm and 20 mm (0.4 in. and 0.8 in.).

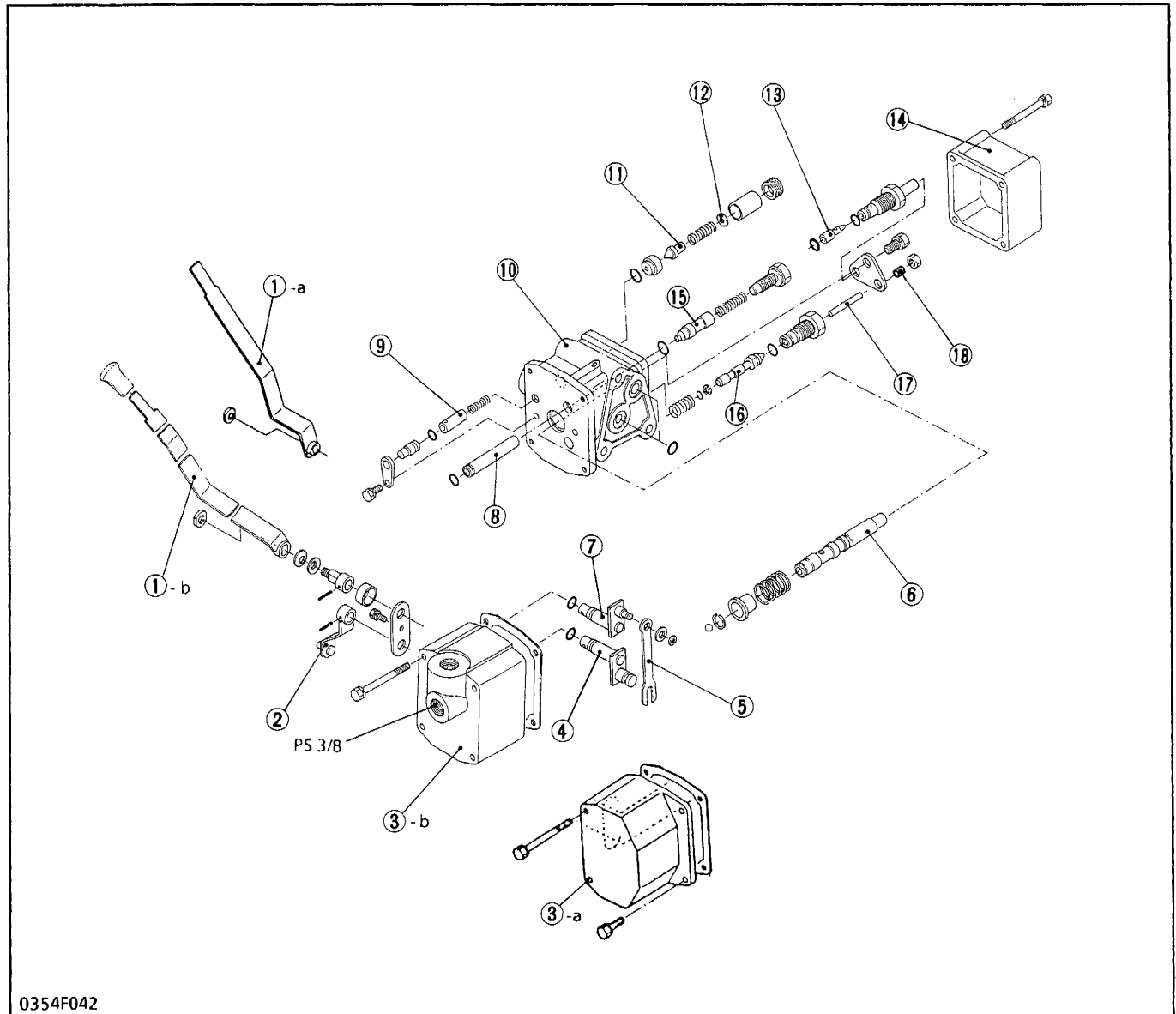

0354F042

- (1)-a Control Lever (B1550-B1750-B1550HST-B1750HST)
- (1)-b Control Lever (B2150-B2150HST)
- (2) Feedback Arm
- (3)-a Valve Cover (B1550-B1750-B1550HST-B1750HST-B2150)
- (3)-b Valve Cover (B2150HST)
- (4) Feedback Lever Shaft
- (5) Spool Drive Lever
- (6) Spool
- (7) Control Lever Shaft
- (8) Pipe (B2150HST)
- (9) Unload Valve 2 Poppet
- (10) Valve Body
- (11) Relief Valve Poppet
- (12) Adjusting Shim
- (13) Check Valve 1 Poppet
- (14) Relief Cover
- (15) Unload Valve 1 Poppet
- (16) Check Valve 2 Poppet
- (17) Push Rod
- (18) Screw (Neutral Adjusting)

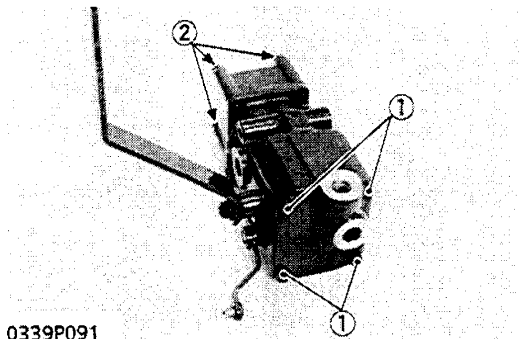

0339P091

(1) Screws

(2) Screws

Covers

1. Remove four screws (1) for mounting the valve cover.
2. Remove the valve cover and pipe for connecting the valve body and valve cover.
3. Remove four screws (2) for mounting the relief cover.

(When reassembling)

Tightening torque	Cover mounting screws (1) (2)	7.8 to 11.7 N·m 0.8 to 1.2 kgf·m 5.8 to 8.7 ft-lbs
-------------------	----------------------------------	--

This photo. shows the control valve of B2150HST.

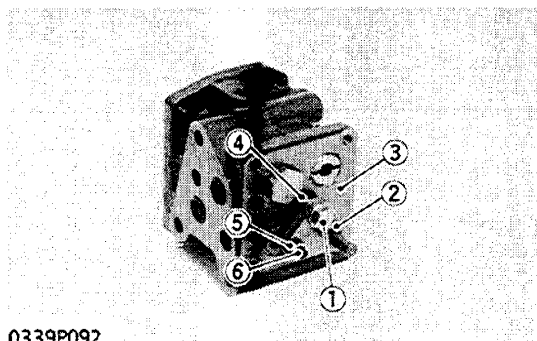

0339P092

- (1) Screw
- (2) Connecting Plate
- (3) Valve Body
- (4) Spool
- (5) Lock Nut
- (6) Screw

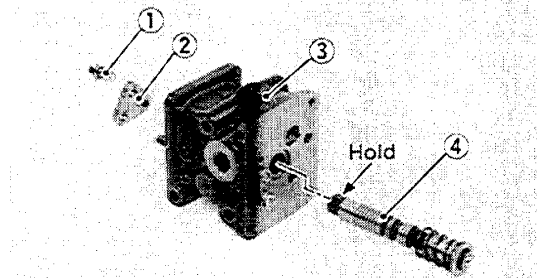

0339P093

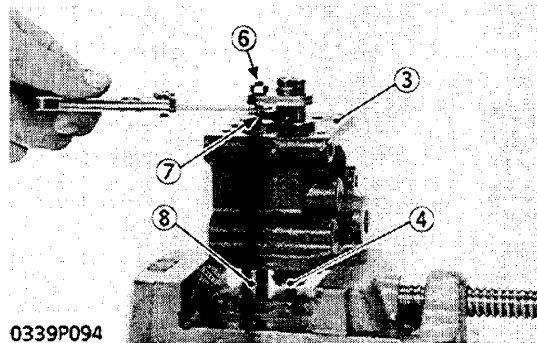

0339P094

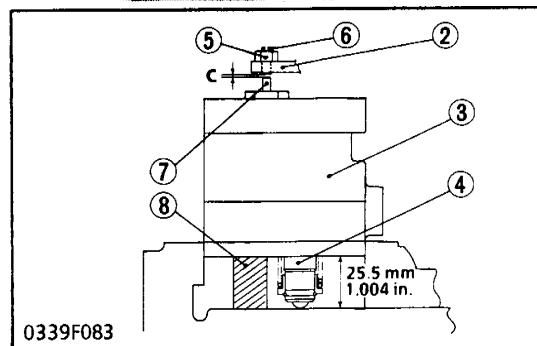

0339F083

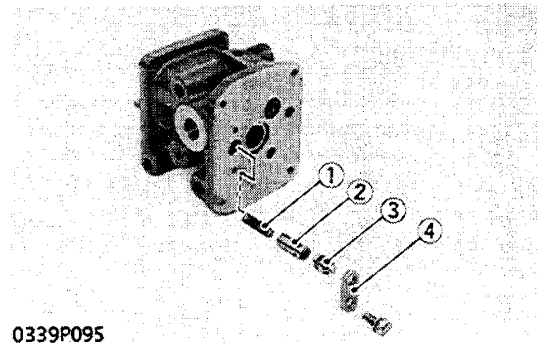

0339P095

Spool

1. Hold the spool (4) with a wrench and remove the screw (1) retaining the connecting plate (2).
2. Pull out the spool (4).

IMPORTANT

- Never loosen the lock nut (5) and never displace the screw (6). If the screw (6) is displaced, the control valve will malfunction. For instance, if the screw (6) is loosened and clearance "C" between screw (6) and push rod (7) becomes larger than factory set clearance at the neutral, the implement will not lower the specified height. And if the screw (6) is more screwed in and the clearance "C" is less than factory set clearance at the neutral, the implement will hunt.
- If the screw (6) is displaced or control valve malfunctions, adjust the neutral position with the screw (6) as follows.

(When reassembling)

Tightening torque	Connecting plate retaining screw (1)	23.6 to 27.4 N·m 2.4 to 2.8 kgf·m 17.4 to 20.2 ft·lbs
-------------------	--------------------------------------	---

Adjusting Neutral Position of Control Valve

1. Put a block (8) of 25.5 mm (1.004 in.) height on the vise.
2. Depress the valve body (3) until it touches the block (8) and secure it in a vise so that the machined surface of the valve body (3) is horizontal.
3. Adjust the clearance "C" between screw (6) and push rod (7) to 0.3 to 1.0 mm (0.0118 to 0.0394 in.) with the screw (6). And then, tighten the lock nut (5).

Tightening torque	Lock nut	9.8 to 14.7 N·m 1.00 to 1.50 kgf·m 7.24 to 10.9 ft·lbs
-------------------	----------	--

4. After reassembling and mounting the control valve, check the function of the valve.

- When the control lever is moved to the front end, if the center of the lower link rear end does not lower to the height of about 265 mm (10.4 in.) from the ground, narrow the clearance "C" a little with the screw (6).
- If the implement hunts, expand the clearance "C" a little with the screw (6).

(7) Push Rod

(8) Block

Unload Valve 2

1. Remove the screw mounting the retaining plate (4).
2. Pull out the cover (3), poppet (2) and spring (1) from the valve body.

- (1) Spring
- (2) Poppet

- (3) Cover
- (4) Retaining Plate

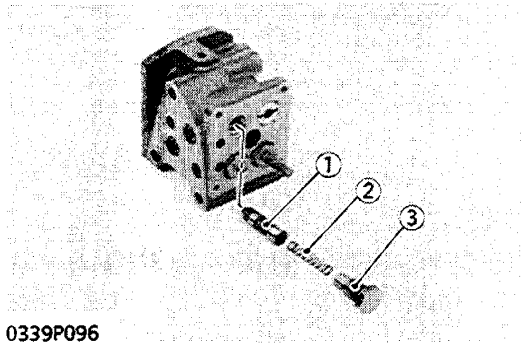

Unload Valve 1

1. Remove the plug (3), spring (2) and poppet (1) from the valve body.

(When reassembling)

Tightening torque	Plug (3)	29.4 to 49.0 N·m 3.0 to 5.0 kgf·m 21.7 to 36.2 ft-lbs
-------------------	----------	---

- (1) Poppet (3) Plug
(2) Spring

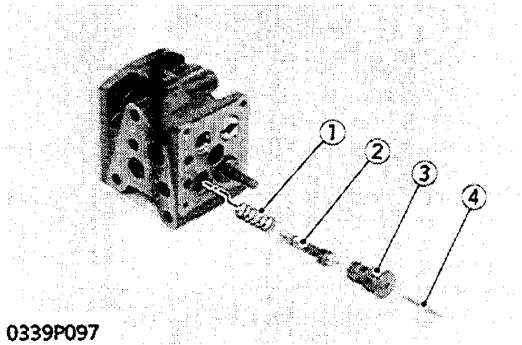

Check Valve 2 (for Lowering)

1. Remove the push rod (4), plug 2 (3), poppet (2) and spring (1) from the valve body.

(When reassembling)

Tightening torque	Plug 2 (3)	39.2 to 58.8 N·m 4.0 to 6.0 kgf·m 28.9 to 43.4 ft-lbs
-------------------	------------	---

- (1) Spring (3) Plug 2
(2) Poppet (4) Push Rod

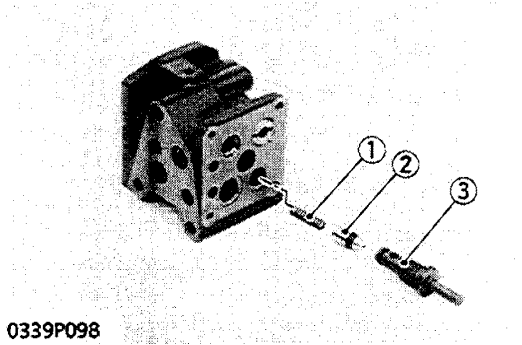

Check Valve 1

1. Remove the plug 1 (3), poppet (2) and spring (1) from the valve body.

(When reassembling)

Tightening torque	Plug 1 (3)	29.4 to 49.0 N·m 3.0 to 5.0 kgf·m 21.7 to 36.2 ft-lbs
-------------------	------------	---

- (1) Spring (3) Plug 1
(2) Poppet

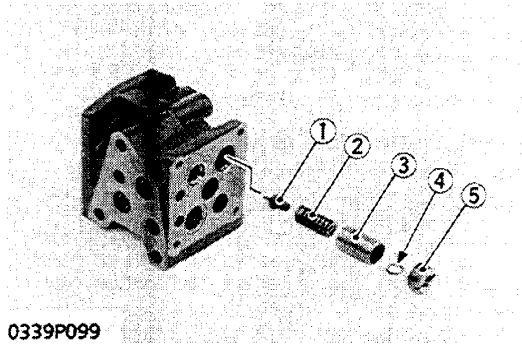

Relief Valve

1. Remove the plug (5), adjusting shim (4), collar (3), spring (2) and poppet (1) from the valve body.

(When reassembling)

- After tightening the plug (5), stake it with a punch.

- (1) Poppet (4) Adjusting Shim
(2) Spring (5) Plug
(3) Collar

[3] HYDRAULIC CYLINDER ADJUSTING

[B1550-B1750-B1550HST-B1750HST]

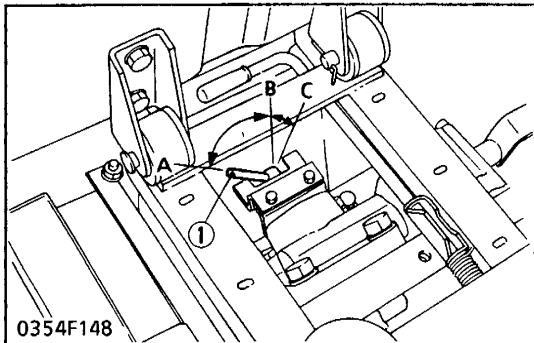

0354F148

Lift Arm Lowering Speed

1. Adjust the lift arm lowering speed by turning the adjusting lever.

(1) Adjusting Lever

- A : Lock (Stop)
- B : Down Slow
- C : Down Fast

[B2150-B2150HST]

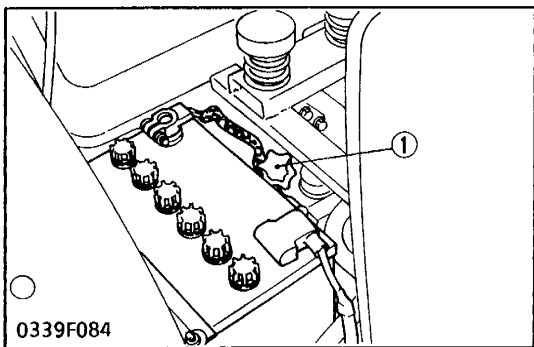

0339F084

Lift Arm Lowering Speed

1. Adjust the lift arm lowering speed by turning the adjusting grip.

(1) Adjusting Grip

DISASSEMBLING AND ASSEMBLING

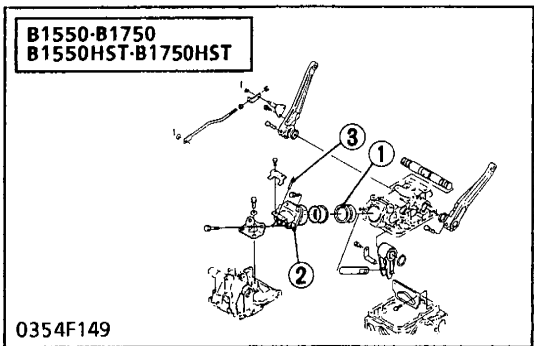

0354F149

Cylinder Cap and Piston

1. Remove the cylinder cap (2).
2. Draw out the piston (1) from the cylinder.

(When reassembling)

- Install the piston, noting O-ring and backup ring.
- Install the cylinder cap, noting O-ring.

Tightening torque	Cylinder cap mounting screw	B1550 B1750 B1550HST B1750HST	60.8 to 106.8 N·m 6.2 to 10.9 kgf·m 44.8 to 78.8 ft·lbs
		B2150 B2150HST	34.3 to 39.2 N·m 3.5 to 4.0 kgf·m 25.3 to 28.9 ft·lbs

- (1) Piston
- (2) Cylinder Cap
- (3) Spring Pin

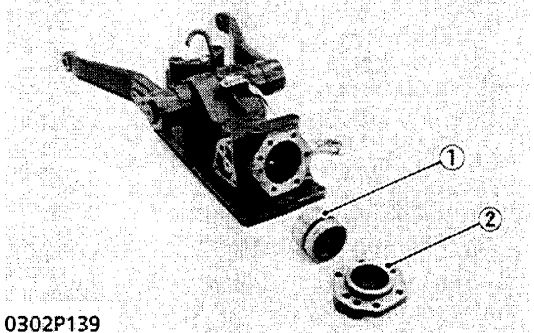

0302P139

※1 Tightening torque	Cylinder cap mounting screw	B1550E above 10391 B1550D above 52017 B1750E above 10348 B1750D above 52278 B1550HSE above 20161 B1550HSD above 61959 B1750HSE above 20195 B1750HSD above 62951	77.5 to 90.1 N·m 7.9 to 9.2 kgf·m 57.2 to 66.5 ft·lbs
-------------------------	-----------------------------	--	---

※ Refer to page S.8-17.

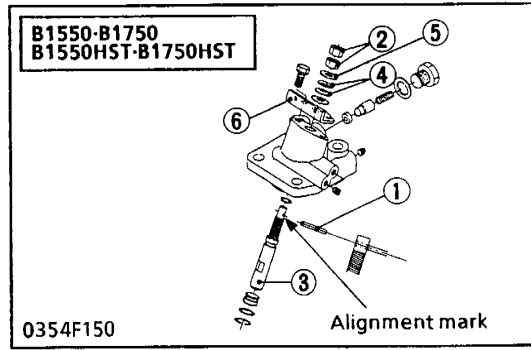

- (1) Spring Pin
- (2) Nut
- (3) Rotor
- (4) Spring
- (5) Plain Washer
- (6) Plate

Lowering Speed Adjusting Shaft

(B1550-B1750-B1550HST-B1750HST) ※1

1. Remove the spring pin (1) and nuts (2) from the rotor (3) and remove the springs (4), plain washers (5), plate (6) and rotor (3).

(When reassembling)

- Set the long spring pin (1) to the rotor from the side of alignment mark on it until the pin touches the other side of rotor.
- Direct the alignment mark forward.

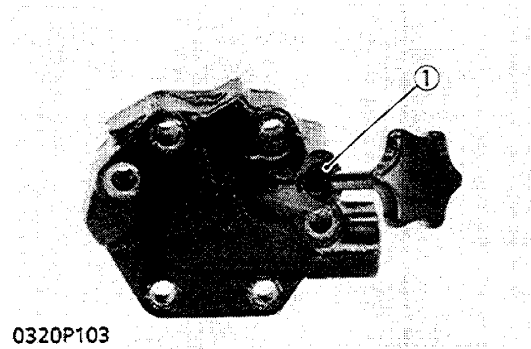

Lowering Speed Adjusting Shaft (B2150-B2150HST)

1. Remove the internal snap rings (1), (3), and remove the lowering speed adjusting shaft (2).

NOTE

- Lowering speed adjusting screw is left hand threaded.

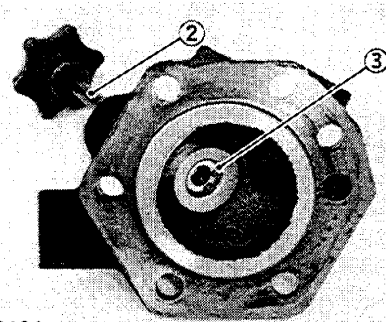

- (1) Internal Snap Ring
- (2) Adjusting Shaft
- (3) Internal Snap Ring

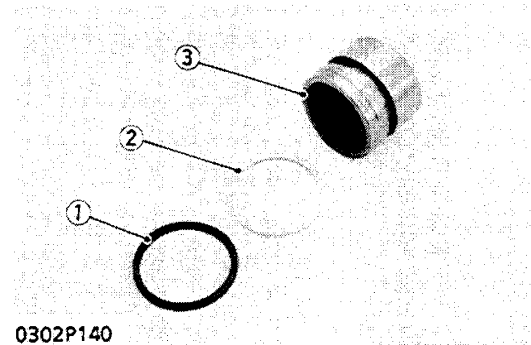

O-ring and Backup Ring

1. Remove the O-ring (1) and backup ring (2) from the piston (3).

(When reassembling)

- Install the backup ring, noting its direction.
- Replace the O-ring if it is defective, worn or scratched, which may cause oil leaks.

- (1) O-ring
- (2) Backup Ring
- (3) Piston

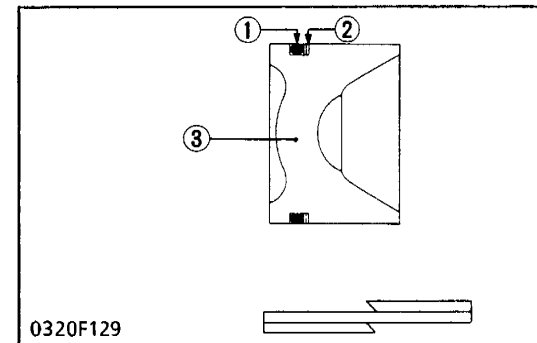

NOTE (※1)

- Refer to the table on the left page for the tightening torque of the cylinder cap mounting screw.
- The new lowering speed adjusting shaft is as follows.

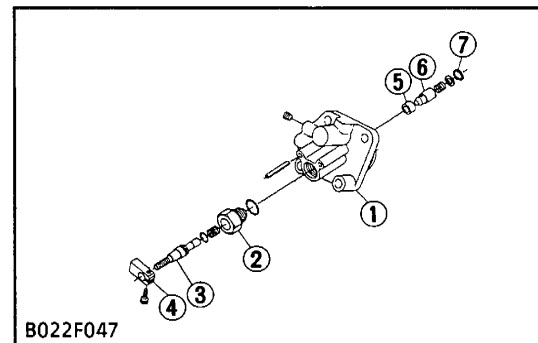

- (1) Cap Body
- (2) Plug
- (3) Adjust Shaft
- (4) Lever
- (5) Valve Seat
- (6) Poppet
- (7) Internal Snap Ring

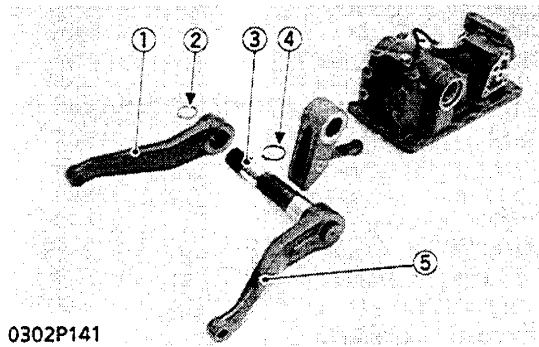

0302P141

Lift Arm and Rockshaft

1. Remove the external snap ring (2), and remove the lift arm LH (1) from the rockshaft.
2. Remove the external snap ring (4) from the rockshaft.
3. Remove the rockshaft (3) and lift arm RH (5) as an assembly.

(When reassembling)

- Apply grease to the right and left bushings of hydraulic cylinder.
- Properly align the alignment marks (6) of the rockshaft and rockshaft arm, and the alignment marks (7) of the rockshaft and lift arm.

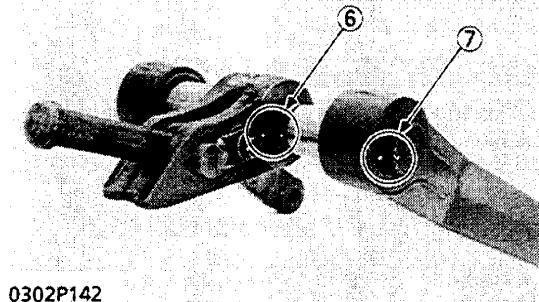

0302P142

- | | |
|------------------------|-----------------|
| (1) Lift Arm LH | (5) Lift Arm RH |
| (2) External Snap Ring | (6) Marks |
| (3) Rockshaft | (7) Marks |
| (4) External Snap Ring | |

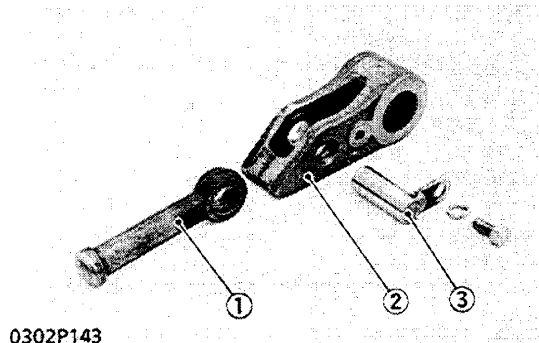

0302P143

Separation of Rockshaft Arm and Piston Rod

1. Remove the set pin (3), and separate the rockshaft arm (2) and piston rod (1).

Tightening torque	Set pin mounting screw	B1550 B1750 B1550HST B1750HST	23.6 to 27.4 N·m 2.4 to 2.8 kgf·m 17.4 to 20.2 ft·lbs
		B2150 B2150HST	48.1 to 55.9 N·m 4.9 to 5.7 kgf·m 35.4 to 41.2 ft·lbs

- | | |
|-------------------|-------------|
| (1) Piston Rod | (3) Set Pin |
| (2) Rockshaft Arm | |

SERVICING

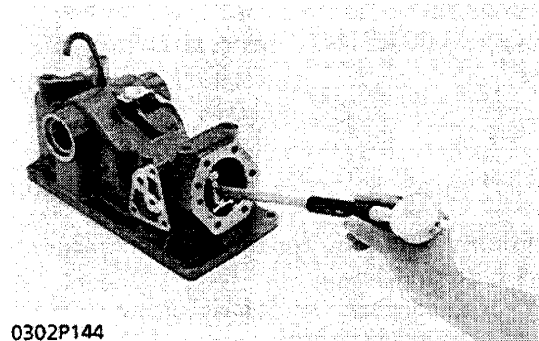

0302P144

Hydraulic Cylinder Wear

1. Measure the hydraulic cylinder I.D. with a cylinder gauge.
2. If the hydraulic cylinder I.D. exceeds the allowable limit, replace it.

Hydraulic cylinder I.D.	Factory spec.	B1550 B1750 B1550HST B1750HST	65.06 to 65.10 mm 2.5614 to 2.5630 in.
	Allowable limit		65.15 mm 2.5650 in.
	Factory spec.	B2150 B2150HST	70.06 to 70.10 mm 2.7583 to 2.7598 in.
	Allowable limit		70.15 mm 2.7618 in.

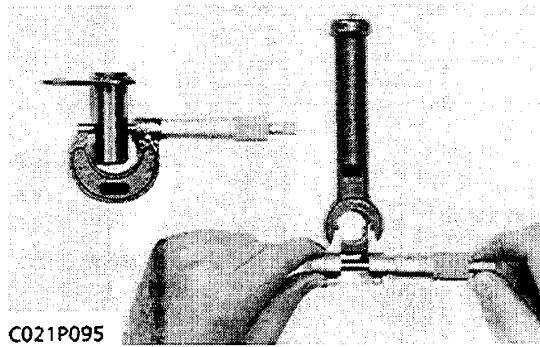

C021P095

Clearance between Piston Rod and Set Pin

1. Measure the piston rod I.D. (Set pin hole) with an inside micrometer.
2. Measure the set pin O.D. with an outside micrometer.
3. If the clearance exceeds the allowable limit, replace it.

Clearance between piston rod and set pin	Factory spec.	0.020 to 0.124 mm 0.0008 to 0.0048 in.
	Allowable limit	0.40 mm 0.0157 in.

Piston rod I.D.	Factory spec.	B1550-B1750 B1550HST B1750HST	15.03 to 15.15 mm 0.592 to 0.596 in.
		B2150 B2150HST	22.020 to 22.072 mm 0.8670 to 0.8689 in.
Set pin O.D.	Factory spec.	B1550-B1750 B1550HST B1750HST	14.957 to 14.984 mm 0.5889 to 0.5899 in.
		B2150 B2150HST	21.948 to 22.000 mm 0.8641 to 0.8661 in.

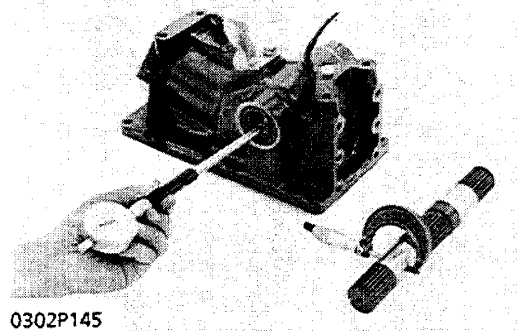

0302P145

Clearance between Rockshaft and Bushing

1. Measure the rockshaft O.D. with an outside micrometer.
2. Measure the bushing I.D. with a cylinder gauge.
3. If the clearance exceeds the allowable limit, replace it.

Clearance between piston rod and set pin	Factory spec.	0.075 to 0.114 mm 0.0030 to 0.0045 in.
	Allowable limit	0.30 mm 0.0118 in.

Rockshaft O.D.	Factory spec.	B1550 B1750 B1550HST B1750HST	Right side	34.925 to 34.950 mm 1.3750 to 1.3760 in.
			Left side	29.939 to 29.960 mm 1.1787 to 1.1795 in.
		B2150 B2150HST	Right side	39.925 to 39.950 mm 1.5719 to 1.5728 in.
			Left side	34.925 to 34.950 mm 1.3750 to 1.3760 in.
Bushing I.D.	Factory spec.	B1550 B1750 B1550HST B1750HST	Right side	35.025 to 35.039 mm 1.3789 to 1.3795 in.
			Left side	30.025 to 30.039 mm 1.1821 to 1.1826 in.
		B2150 B2150HST	Right side	40.025 to 40.039 mm 1.5758 to 1.5763 in.
			Left side	35.025 to 35.039 mm 1.3789 to 1.3795 in.

[4] HYDRAULIC BLOCK TYPE OUTLET

CHECKING AND ADJUSTING

[B1550-B1750-B1550HST-B1750HST]

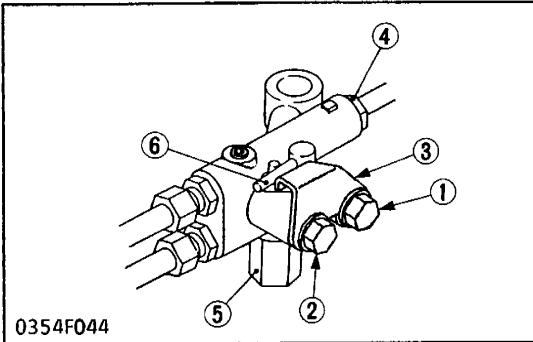

0354F044

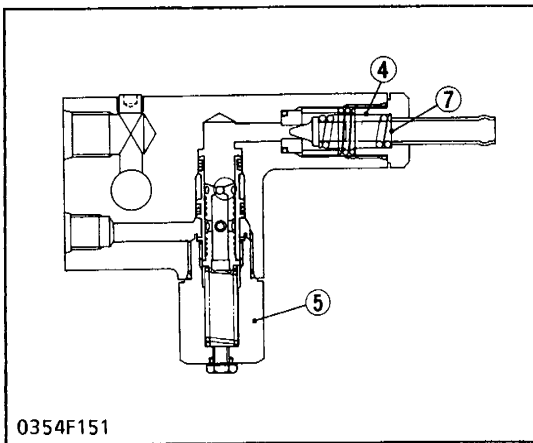

0354F151

Relief Valve Setting Pressure

1. Remove the plugs (1), (2), lock plate (3) and install the adaptor C instead of the plug (1). Then, attach the relief setting pressure tester (Code No: 07916-50045) to this adaptor.

Adaptor C	Screw size	PS 3/8"
-----------	------------	---------

2. Start the engine, warm it up, and set the engine speed at 2600 rpm.

3. Slowly turn the directional valve (6) clockwise, and read the pressure gauge indicating the relief valve operation is heard.

4. If the pressure is not within the factory specifications adjust with the adjusting shim (7) in the relief valve body.

Relief valve setting pressure	Factory spec.	15.7 to 16.2 MPa 160 to 165 kgf/cm ² 2275 to 2347 psi
-------------------------------	---------------	--

● Adjusting shims

Code No.	67111-37531	0.3 mm (0.0118 in.)
	67111-37581	0.8 mm (0.0315 in.)

- | | |
|--------------------------------------|--------------------------------------|
| (1) Plug (PS 3/8") (to implements) | (5) Flow Priority Valve |
| (2) Plug (PS 3/8") (from implements) | (6) Directional Valve |
| (3) Lock Plate | (7) Adjusting Shim (0.3 mm, 0.8 in.) |
| (4) Relief Valve | |

[B2150-B2150HST]

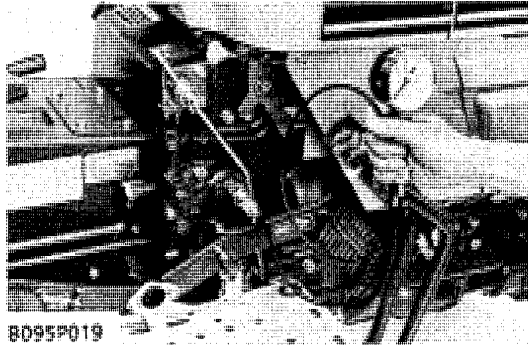

8095P019

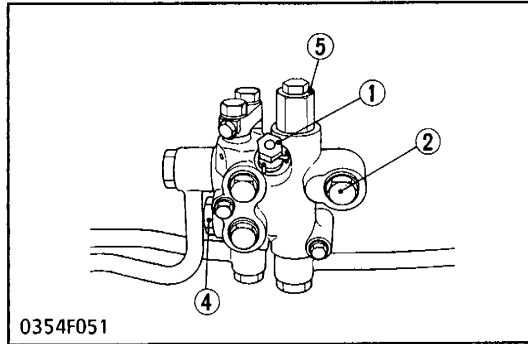

0354F051

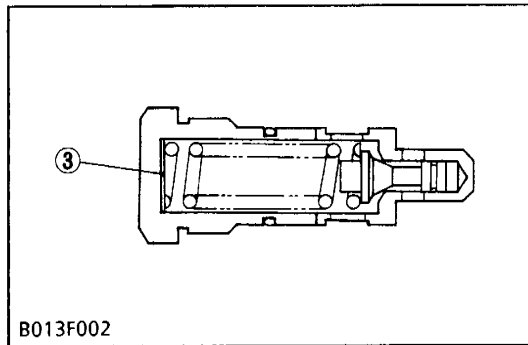

B013F002

Relief Valve Setting Pressure

1. Remove the plug (2) and install the adaptor C instead of the plug (2). Then, attach the relief setting pressure tester (Code No.: 07916-50045) to this adaptor.

Adaptor C	Screw size	PS 3/8"
-----------	------------	---------

2. Start the engine, warm it up, and set the engine speed at 2600 rpm.
3. Slowly turn the directional valve (1) clockwise, and read the pressure gauge indicating the relief valve operation is heard.
4. If the pressure is not within the factory specifications adjust with the adjusting shim (3) in the relief valve body.

Relief valve setting pressure	Factory spec.	14.7 to 15.2 MPa 150 to 155 kgf / cm ² 2133 to 2204 psi
-------------------------------	---------------	--

- | | |
|-----------------------|-------------------------|
| (1) Directional Valve | (4) Relief Valve |
| (2) Plug | (5) Flow Priority Valve |
| (3) Adjusting Shim | |

DISASSEMBLING AND ASSEMBLING

[B1550-B1750-B1550HST-B1750HST]

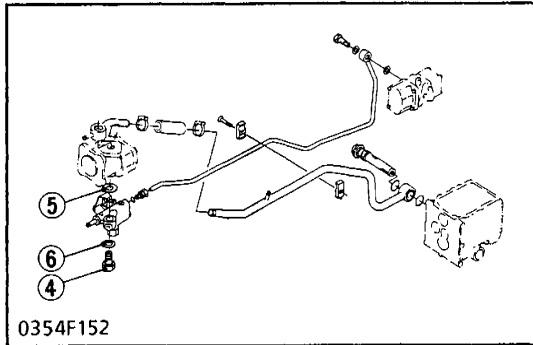

Hydraulic Block Type Outlet

1. Disconnect each pipe connection nut (1), (2) and (3).
2. Remove the hydraulic block type outlet eye joint bolt (4) and remove the hydraulic block type outlet.

(When reassembling)

- When connecting the outlet, install the copper gaskets (5), (6).

Tightening torque	Return pipe (to pump) eye joint bolt	53.9 to 68.6 N·m 5.5 to 7.0 kgf·m 39.8 to 50.6 ft-lbs
	Delivery pipe (to control valve) eye joint bolt	53.9 to 68.6 N·m 5.5 to 7.0 kgf·m 39.8 to 50.6 ft-lbs
	Delivery pipe (to power steering valve) eye joint bolt	53.9 to 68.6 N·m 5.5 to 7.0 kgf·m 39.8 to 50.6 ft-lbs
	Hydraulic block type outlet eye joint bolt	68.6 to 88.2 N·m 7.0 to 9.0 kgf·m 50.6 to 65.1 ft-lbs

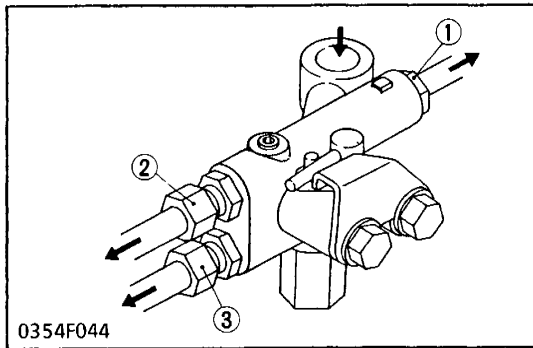

- | | |
|----------------------------------|--|
| (1) Return Pipe Eye Joint Bolt | (4) Hydraulic Type Outlet Eye Joint Bolt |
| (2) Delivery Pipe Eye Joint Bolt | (5) Copper Gasket |
| (3) Delivery Pipe Eye Joint Bolt | (6) Copper Gasket |

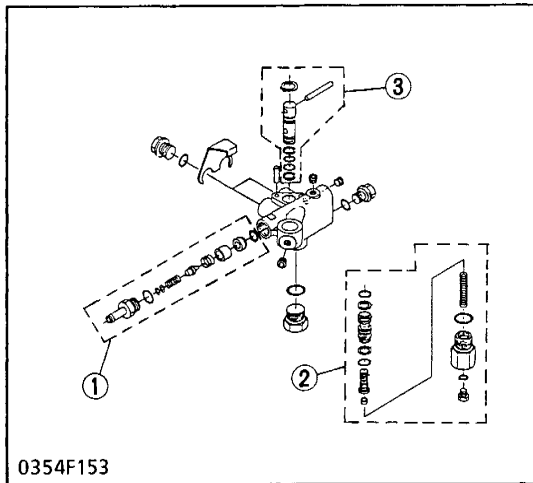

Relief Valve Assembly

1. Separate the relief valve assembly (1).

(When reassembling)

- Install the relief valve assembly to the outlet, taking care not to damage the O-ring.

Tightening torque	Relief valve assembly	49.0 to 58.8 N·m 5.0 to 6.0 kgf·m 36 to 43 ft-lbs
-------------------	-----------------------	---

- | | |
|---------------------------|--------------------------------|
| (1) Relief Valve Assembly | (3) Directional Valve Assembly |
| (2) Flow Divider Assembly | |

Flow Divider Assembly

1. Separate the flow divider assembly (2).

(When reassembling)

- Install the flow divider assembly to the outlet, using care not to damage the O-ring.

Tightening torque	Flow divider assembly	49.0 to 58.8 N·m 5.0 to 6.0 kgf·m 36 to 43 ft-lbs
-------------------	-----------------------	---

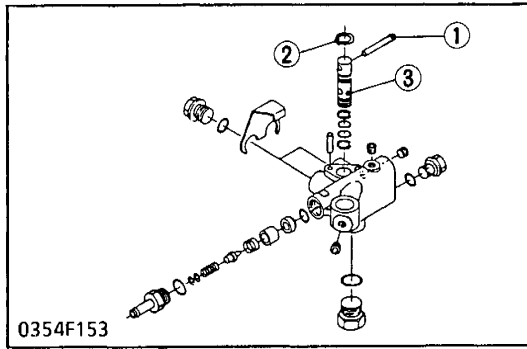

Directional Valve and Cap

1. Tap out the straight pin (1), and remove the external snap ring (2).
2. Remove the directional valve (3).

(When reassembling)

- Install the O-rings and backup rings to the directional valve, taking care not to damage them. Apply grease to them before installation.

- (1) Straight Pin
- (2) External Snap Ring
- (3) Directional Valve

[B2150-B2150HST]

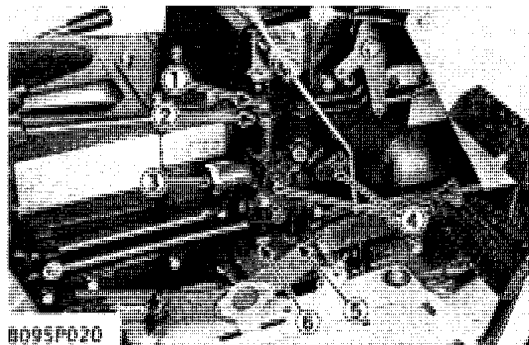

Hydraulic Block Type Outlet

1. Remove the joint bolts (1), (2) (3), (5) and (6).
2. Remove the hydraulic block type outlet mounting screws (4), and remove the hydraulic block type outlet.

(When reassembling)

- When connecting the pipes, install the copper gaskets (7) (8) (9) (10) at the both ends of the pipe.

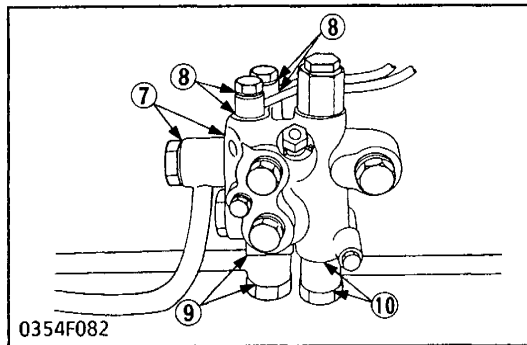

Tightening torque	Delivery pipe 1 eye joint bolt	53.9 to 68.6 N·m 5.5 to 7.0 kgf·m 39.8 to 50.6 ft-lbs
	Delivery pipe 2 eye joint bolt	53.9 to 68.6 N·m 5.5 to 7.0 kgf·m 39.8 to 50.6 ft-lbs
	Return pipe 1 eye joint bolt	53.9 to 68.6 N·m 5.5 to 7.0 kgf·m 39.8 to 50.6 ft-lbs
	Power steering pipe eye joint bolt	39.2 to 44.1 N·m 4.0 to 4.5 kgf·m 28.9 to 32.5 ft-lbs
	Hydraulic block type outlet mounting screw	17.7 to 19.7 N·m 1.8 to 2.1 kgf·m 13.0 to 14.5 ft-lbs

- (1) Joint Bolt (power steering return pipe)
- (2) Joint Bolt (power steering delivery pipe)
- (3) Joint Bolt (delivery pipe 2) (Long)
- (4) Hydraulic Block Type Outlet Mounting Screws
- (5) Joint Bolt (delivery pipe 1) (Short)
- (6) Joint Bolt (return pipe) (Short)
- (7) Copper Gasket
- (8) Copper Gasket
- (9) Copper Gasket
- (10) Copper Gasket

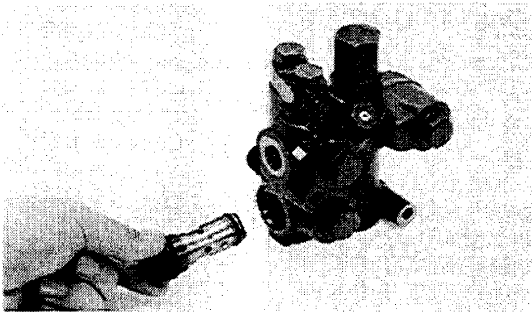

0320P108

Relief Valve Assembly

1. Separate the relief valve assembly.

(When reassembling)

- Install the relief valve assembly to the outlet, taking care not to damage the O-ring.

Tightening torque	Relief valve assembly	49.0 to 58.8 N·m 5.0 to 6.0 kgf·m 36 to 43 ft-lbs
-------------------	-----------------------	---

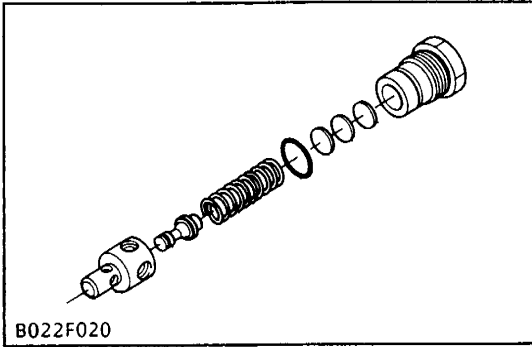

B022F020

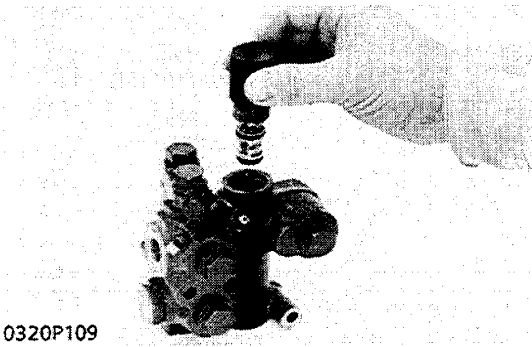

0320P109

Flow Divider Assembly

1. Separate the flow divider assembly.

(When reassembling)

- Install the flow divider assembly to the outlet, taking care not to damage the O-ring.

Tightening torque	Flow divider assembly	49.0 to 58.8 N·m 5.0 to 6.0 kgf·m 36 to 43 ft-lbs
-------------------	-----------------------	---

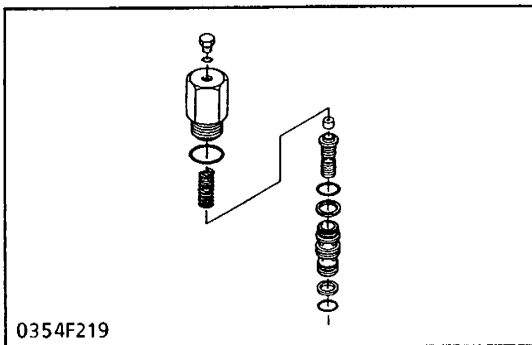

0354F219

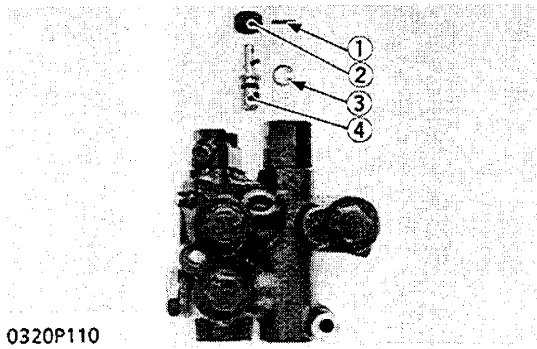

0320P110

Directional Valve and Cap

1. Tap out the spring pin (1), and remove the nut (2).
2. Remove the internal snap ring (3), and remove the directional valve (4).

- (1) Spring Pin
- (2) Nut

- (3) Internal Snap Ring
- (4) Directional Valve

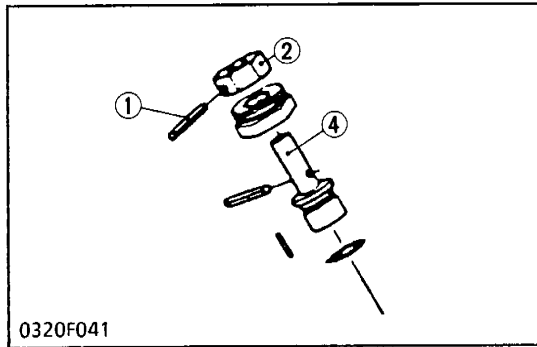

0320F041

**S.9 ELECTRICAL
SYSTEM**

CONTENTS

TROUBLESHOOTING	S.9-1
SERVICING SPECIFICATIONS	S.9-4
CHECKING, DISASSEMBLING AND SERVICING	S.9-5
[1] BATTERY	
CHECKING	S.9-5
[2] STARTING SYSTEM	
CHECKING	S.9-7
[B1550-B1750-B1550HST-B1750HST]	
TEST	S.9-10
DISASSEMBLING AND ASSEMBLING	S.9-10
SERVICING	S.9-12
[B2150-B2150HST]	
TEST	S.9-15
DISASSEMBLING AND ASSEMBLING	S.9-16
SERVICING	S.9-17
[3] ENGINE KEY SWITCH SHUT-OFF SYSTEM	
ADJUSTING	S.9-19
CHECKING	S.9-20
[4] CHARGING SYSTEM	
CHECKING	S.9-22
[5] LIGHTING SYSTEM	
CHECKING	S.9-23
[6] EASY CHECKER	
CHECKING	S.9-26
[7] GAUGE	
CHECKING	S.9-28

TROUBLESHOOTING

Symptom	Probable Cause	Solution	Reference Page
All Electrical Equipments Do Not Operate	● Battery discharged or defective	Recharge or Replace	S.9-6, 7
	● Battery positive cable disconnected or improperly connected	Repair or Replace	S.9-5
	● Battery negative cable disconnected or improperly connected	Repair or Replace	S.9-5
	● Fusible link blown	Replace	—
Fuse Blown Frequently	● Short-circuited	Repair or Replace	—

BATTERY

Battery Discharges Too Quickly	● Battery defective	Recharge or Replace	S.9-6,7
	● Dynamo defective	Repair or Replace	S.9-22
	● Regulator defective	Replace	S.9-22
	● Wiring harness disconnected or improperly connected (between battery positive terminal and dynamo B terminal, between battery positive terminal and regulator B terminal)	Repair or Replace	S.9-22
	● Cooling fan belt slipping	Adjust tension	S.G-7,15

STARTING SYSTEM

Starter Motor Does Not Operate	● Battery discharged or defective	Recharge or Replace	S.9-6,7
	● Fusible link blown	Replace	—
	● Safety switch improperly adjusted or defective	Repair or Replace	S.9-9
	● Wiring harness disconnected or improperly connected (between main switch ST terminal and safety switch, between safety switch and starter motor, between battery positive terminal and starter motor)	Repair or Replace	S.9-7,8,9
	● Starter motor defective ● Main switch defective	Repair or Replace Replace	S.9-10,15 S.9-7,8
Glow Plug Indicator Does Not Glow	● Battery discharged or defective	Recharge or Replace	S.9-6,7
	● Fusible link blown	Replace	—
	● Wiring harness disconnected or improperly connected (between main switch G terminal and glow plug indicator, between glow plug indicator and glow plugs)	Repair or Replace	S.9-7,8,9
	● Main switch defective	Replace	S.9-7,8
	● Glow plug indicator defective	Replace	S.9-27

ENGINE KEY SWITCH SHUT-OFF SYSTEM

Symptom	Probable Cause	Solution	Reference Page
Engine Does Not Stop When Main Switch is Turned Off	<ul style="list-style-type: none"> ● Fuse blown (15A) Fusible link ● Timer defective ● Wiring harness disconnected or improperly connected (between main switch AC terminal, between timer relay 4 terminal, between timer relay 1 terminal and fuel cut off solenoid) ● Fuel cut off solenoid defective 	Replace Replace Repair or Replace Replace	— S.9-20 S.9-20 S.9-21
Engine Does Not Start	<ul style="list-style-type: none"> ● Engine stop timer relay defective ● Fuel cut off solenoid defective 	Replace Replace	S.9-20 S.9-21

CHARGING SYSTEM

Charging Lamp Does Not Light When Main Switch is Turned ON	<ul style="list-style-type: none"> ● Fuse blown (15A) ● Wiring harness disconnected or improperly connected (between main switch AC terminal and panel board, between panel board and regulator terminal (Green)) ● Regulator defective 	Replace Repair or Replace Repair or Replace	— S.9-22 S.9-22
Charging Lamp Does Not Go Off When Engine is Running	<ul style="list-style-type: none"> ● Wiring harness disconnected or improperly connected (between dynamo N terminal and regulator N terminal, between main switch B terminal and regulator B terminal, between panel board and regulator terminal) ● Dynamo defective ● Regulator defective 	Repair or Replace Repair or Replace Replace	S.9-22 S.9-22 S.9-22

LIGHTING SYSTEM

HEADLIGHT DOES NOT LIGHT	<ul style="list-style-type: none"> ● Fuse blown (15A) ● Bulb blown ● Wiring harness disconnected or improperly connected (between main switch AC terminal and combination switch B1 terminal, between combination switch 1 terminal and headlight, between combination switch 2 terminal and headlight) 	Replace Replace Repair or Replace	— — S.9-23,24
Illumination Light Does Not Light	<ul style="list-style-type: none"> ● Fuse blown (15A) ● Bulb blown ● Wiring harness disconnected or improperly connected (between combination switch T terminal and panel board) 	Replace Replace Repair or Replace	— — S.9-28

Symptom	Probable Cause	Solution	Reference Page
Tail Light Does Not Light	<ul style="list-style-type: none"> ● Fuse blown (15A) ● Bulb blown ● Wiring harness disconnected or improperly connected (between combination switch T terminal and tail light) 	Replace Replace Repair or Replace	— — —
Hazard Light Does Not Light	<ul style="list-style-type: none"> ● Fuse blown (15A) ● Bulb blown ● Wiring harness disconnected or improperly connected (between main switch AC terminal and hazard unit, between hazard unit and combination switch B2 terminal, between combination switch R or L terminal and hazard lights) ● Hazard unit defective ● Combination switch defective 	Replace Replace Repair or Replace Replace Replace	— — S.9-24,25 S.9-25 S.9-23
Hazard Indicator Lamp Does Not Light	<ul style="list-style-type: none"> ● Bulb blown ● Wiring harness disconnected or improperly connected (between combination switch R or L terminal and panel board) 	Replace Repair or Replace	— S.9-24
Hazard Light Does Not Flicker	<ul style="list-style-type: none"> ● Hazard unit defective 	Replace	S.9-25

EASY CHECKER

Indicator Lamps Do Not Go Off When Engine is Running	<ul style="list-style-type: none"> ● Dynamo or regulator defective ● Short circuit between regulator L terminal and chassis ● Circuit in panel board defective 	Repair or Replace Repair Replace	S.9-22 S.9-22,26 S.9-26
Indicator Lamps Do Not Light When Main Switch is Turned ON	<ul style="list-style-type: none"> ● Regulator defective ● Wiring harness disconnected or improperly connected (between panel board and regulator) ● Circuit in panel board defective 	Repair or Replace Repair or Replace Replace	S.9-22 S.9-26 S.9-26,27
Oil Pressure Lamp Lights Up When Engine is Running	<ul style="list-style-type: none"> ● Engine oil pressure too low ● Engine oil insufficient ● Oil pressure switch defective ● Short circuit between oil pressure switch lead and chassis ● Circuit in panel board defective 	Repair engine Replenish Replace Repair Replace	— S.G-3 S.9-27 S.9-26,27
Oil Pressure Lamp Does Not Light When Main Switch is Turned ON and Engine is Not Running	<ul style="list-style-type: none"> ● Bulb blown ● Oil pressure switch defective ● Wiring harness disconnected or improperly connected (between panel board and oil pressure switch) ● Circuit in panel board defective 	Replace Replace Repair or Replace Replace	— S.9-27 S.9-26,27 S.9-26,27

GAUGES

Symptom	Probable Cause	Solution	Reference Page
Fuel Gauge Does Not Function	<ul style="list-style-type: none"> Fuel gauge defective Fuel level sensor (tank unit) defective Wiring harness disconnected or improperly connected (between panel board and fuel level sensor) Circuit in panel board defective 	Replace	S.9-29
		Replace Repair or Replace	S.9-28 S.9-28
Coolant Temperature Gauge Does Not Function	<ul style="list-style-type: none"> Coolant temperature gauge defective Coolant temperature sensor defective Wiring harness disconnected or improperly connected (between panel board and coolant temperature sensor) Circuit in panel board defective 	Replace	S.9-29
		Replace Repair or Replace Replace	S.9-29 S.9-29 S.9-29 —

SERVICING SPECIFICATIONS

STARTER MOTOR

[B1550-B1750-B1550HST-B1750HST]

Item		Factory Specification	Allowable Limit
Shaft to Bushing	Clearance (Commutator Side)	0.03 to 0.10 mm 0.0012 to 0.0039 in.	0.20 mm 0.0079 in.
	(Drive Side)	0.05 to 0.10 mm 0.0020 to 0.0039 in.	0.20 mm 0.0079 in.
Shaft	O.D.	12.50 mm	—
Commutator Bushing	I.D.	12.53 to 12.60 mm 0.4933 to 0.4961 in.	—
Drive Bushing	I.D.	12.55 to 12.60 mm 0.4941 to 0.4961 in.	—
Commutator	O.D.	28.0 mm 1.1024 in.	27.0 mm 1.0630 in.
Mica	Undercut	0.5 to 0.8 mm 0.0197 to 0.0315 in.	0.2 mm 0.0079 in.
Brush	Length	16.0 mm 0.6299 in.	10.5 mm 0.4134 in.

[B2150-B2150HST]

Commutator	O.D.	30.0 mm 1.1811 in.	29.0 mm 1.1417 in.
Mica	Undercut	0.5 to 0.8 mm 0.0197 to 0.0315 in.	0.2 mm 0.0079 in.
Brush	Length	13 mm 0.512 in.	8.5 mm 0.335 in.

CHECKING, DISASSEMBLING AND SERVICING

[1] BATTERY

CHECKING

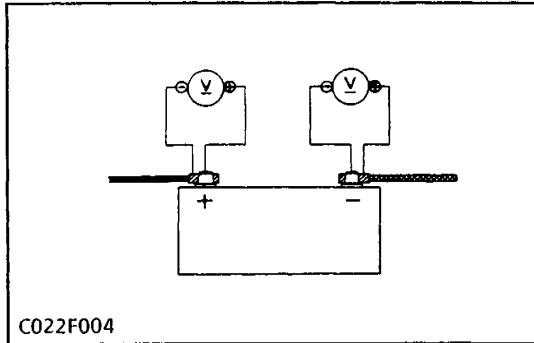

Battery Terminal and Bolt Tightness

1. Activate an electrical load, such as headlights.
2. Connect battery (+) terminal to voltmeter (+) terminal, and (+) cord to voltmeter (-) terminal.
Under normal conditions, the voltmeter will indicate 0V.
3. Check battery (-) terminal in the same manner as above.
Under normal conditions, the voltmeter will indicate 0V.
4. If the voltmeter does not show 0V, clean terminals and cable clamps, and attach the clamps.

Allowable limit	0.1 V
-----------------	-------

NOTE

- If the starter does not run, begin measurements with larger range on the circuit tester proceeding to the lower ranges.

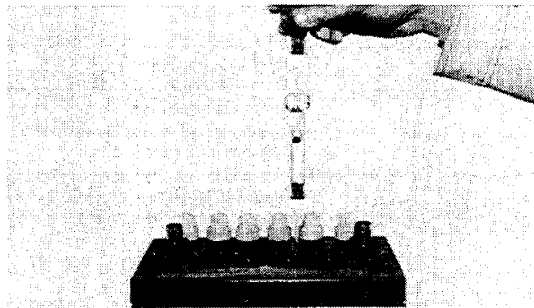

Battery Condition

1) Checking with a Hydrometer

1. Suck electrolyte into the hydrometer and read the specific gravity.
2. Specific gravity slightly varies with temperature.
Therefore, reading of hydrometer decreases by 0.0007 (0.0004) with an increase of 1°C (1°F) in temperature, and increases by 0.0007 (0.0004) with a decrease of 1°C (1°F).
Therefore, using 20°C (68°F) as reference, specific gravity reading must be corrected by the following formula:
Specific gravity at 20°C = Measured value + 0.0007 x (Electrolyte temperature - 20°C)
Specific gravity at 68°F = Measured value + 0.0004 x (Electrolyte temperature - 68°F)

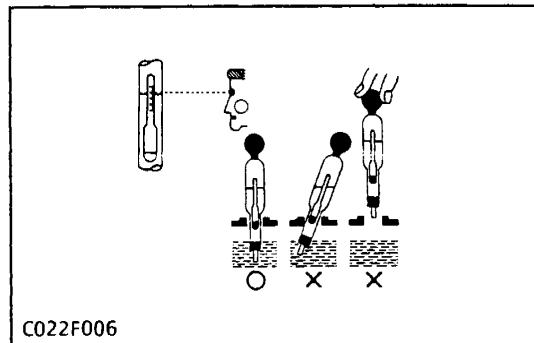

NOTE

- Reading of hydrometer must be taken at the highest liquid level.
- Hold the hydrometer at eye level.
- Hold the hydrometer upright.
- Do not hold the hydrometer above the electrolyte port.

Specific Gravity	Battery Conditions		
	1.260 1.230	100% 75%	Charged
1.200 1.170 1.140	50% 25% 10%	Allowable limit Charged	Must be recharged immediately
1.110	0%	Totally discharged	

At an electrolyte temperature of 20°C. (68°F)

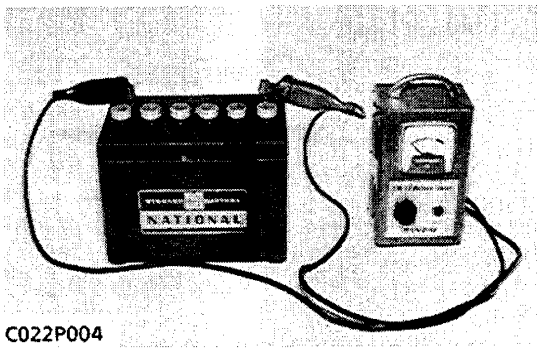

C022P004

2) Checking with a Battery Tester

1. Connect battery tester cords to battery (+) and (-) terminals, set the tester dial for the capacity of the battery to be tested.
2. Keep the switch button pressed for approx. 5 seconds to read the indication needle.

Factory spec	75% or more	Good
	45% to 75%	Needs recharging
	45% or less	Needs recharging or replacement

Before and After Storage

1. After charging fully, store the battery in a well-ventilated place out of direct sunlight.
2. A battery in storage must be recharged monthly. This is because even in storage it self-discharges by approx. 0.5% per day.
3. When storing the battery mounted on the tractor, disconnect the ground cable from the terminal.

● Reference value

Temperature	Self-discharging rate
30°C (86°F)	Approx. 1.0%/day
20°C (68°F)	Approx. 0.5%/day
10°C (50°F)	Approx. 0.25%/day

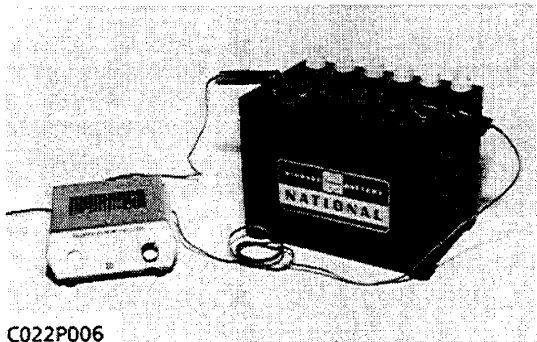

C022P006

Recharging

1) Slow Charging

1. Add distilled water if electrolyte is insufficient. The level of electrolyte should be slightly lower than the specified level to prevent overflow while charging.
2. Connect battery and charging unit properly.
3. Charging current must be 1/20 to 1/10 of battery electric capacity.
4. Electrolyte temperature must not exceed 45°C (113°F) during charging. If it exceeds 45°C (113°F), lower the charging current or stop charging for a while.
5. During charging, electrolyte generates gas. Therefore, remove all port caps.

6. Charging time

$$\text{Charging time} = \frac{\text{Discharging current rate (Ah)}}{\text{Charging current (A)}} \times (1.2 \text{ to } 1.5)$$

7. When charging different capacity batteries at the same time, charging current must be set for the smallest capacity battery.

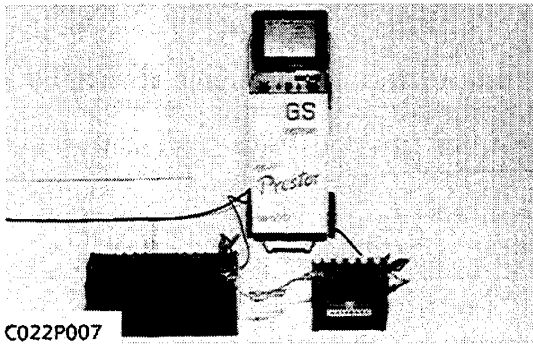

C022P007

2) Quick Charging

1. Determine the proper charging current and charging time with the tester attached to the quick charger.
2. Determine the proper charging current as 1/1 of the battery capacity. If the battery capacity exceeds 50Ah, consider 50A as the maximum.

■ PRECAUTION FOR OPERATING A QUICK CHARGER

- Operation with a quick charger differs according to the type. Consult the instruction manual and use accordingly.

[2] STARTING SYSTEM CHECKING

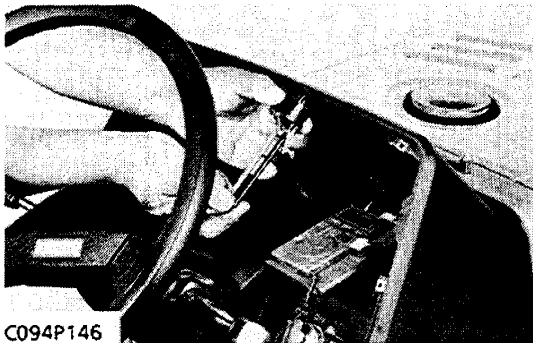

C094P146

Main Switch

1. Remove the panel board from the tractor, and disconnect the main switch connector after turning the main switch off. Perform the following checkings 1) to 5).

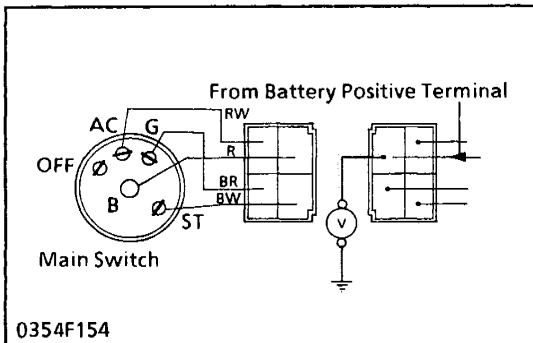

0354F154

1) Connector Voltage

1. Measure the voltage with a voltmeter across the connector B terminal and chassis.
2. If the voltage differs from the battery voltage (11 to 14 V), the wiring harness is faulty.

Voltage	Connector B terminal – chassis	Approx. battery voltage

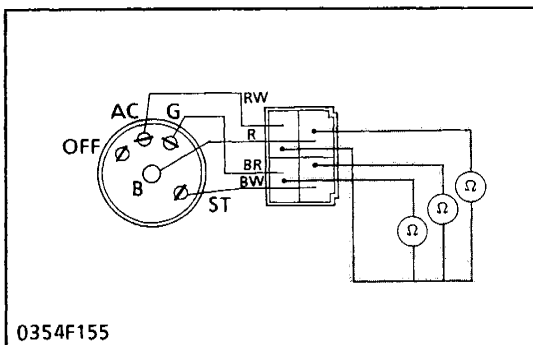

0354F155

2) Main Switch Key at Off Position

1. Turn the main switch off.
2. Measure the resistance with an ohmmeter across the B terminal and the AC terminal, B terminal and ST terminal, B terminal and G terminal.
3. If infinity is not indicated, the contacts of the main switch are faulty.

Resistance	B – AC	Infinity
	B – ST	Infinity
	B – G	Infinity

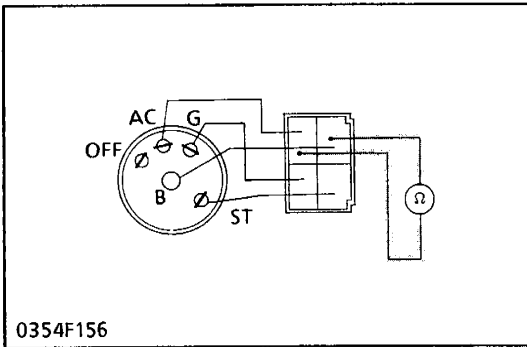

3) Main Switch Key at ON Position

1. Turn the main switch on.
2. Measure the resistance with an ohmmeter across the **B** terminal and the **AC** terminal.
3. If 0 ohm is not indicated, the **B - AC** contacts of the main switch are faulty.

Resistance	B - AC	0 ohm
------------	---------------	-------

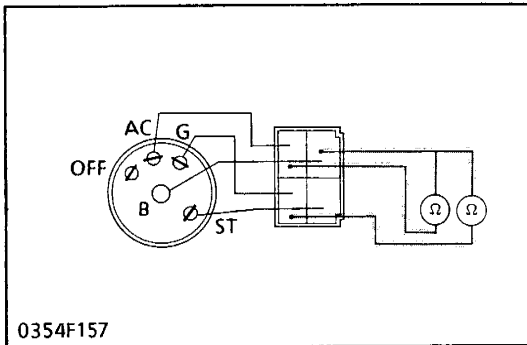

4) Main Switch Key at PREHEAT Position

1. Turn and hold the main switch key at the **PREHEAT** position.
2. Measure the resistance with an ohmmeter across the **B** terminal and the **G** terminal, and measure the resistance across the **B** terminal and the **AC** terminal.
3. If 0 ohm is not indicated, these contacts of the main switch are faulty.

Resistance	B - G	0 ohm
	B - AC	

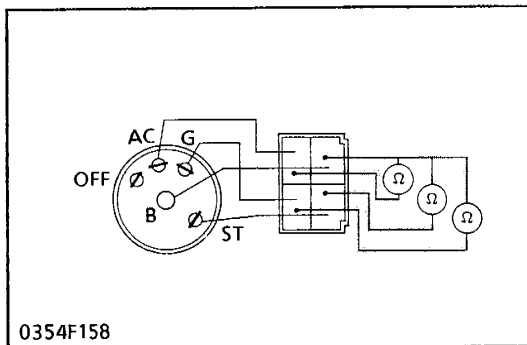

5) Main Switch Key at START Position

1. Turn and hold the main switch key at the **START** position.
2. Measure the resistance with an ohmmeter across the **B** terminal and the **G** terminal, across the **B** terminal and the **ST** terminal, and across the **B** terminal and the **AC** terminal.
3. If 0 ohm is not indicated, these contacts of the main switch are faulty.

Resistance	B - G	0 ohm
	B - ST	
	B - AC	

Key position \ Terminal	B (R)	AC (RW)	G (BR)	ST (BW)
OFF	○			
ON	○	○		
PREHEAT	○	○	○	
START	○	○	○	○

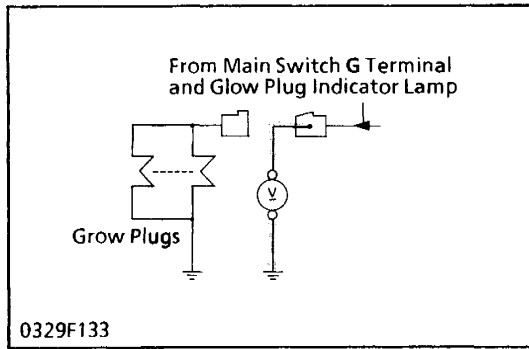

Pre-heating

1) Lead Terminal Voltage

1. Disconnect the wiring lead from the glow plug terminal after turning the main switch off.
2. Turn the main switch key to the **PREHEAT** position, and measure the voltage across the lead terminal and the chassis.
3. Turn the main switch key to the **START** position, and measure the voltage with a voltmeter across the lead terminal and the chassis.
4. If the voltage at either position differs from the battery voltage, the wiring harness or main switch is faulty.

Voltage (Lead terminal chassis)	Main switch key at PREHEAT	Approx. battery voltage
	Main switch key at START	

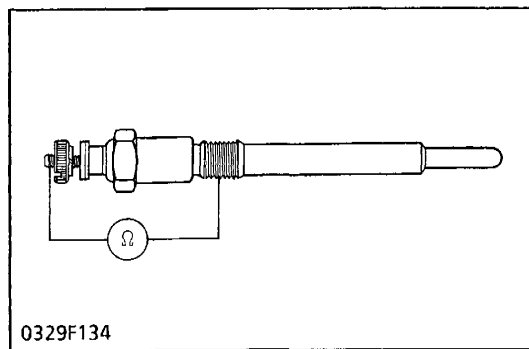

2) Glow Plug

1. Disconnect the leads from the glow plugs.
2. Measure the resistance with an ohmmeter across the glow plug terminal and the chassis.
3. If 0 ohm is indicated, the screw at the tip of the glow plug and the housing are short-circuited.
4. If the reference value is not indicated, the glow plug is faulty.

Glow plug resistance	Reference value	Approx. 0.5 ohms
----------------------	-----------------	------------------

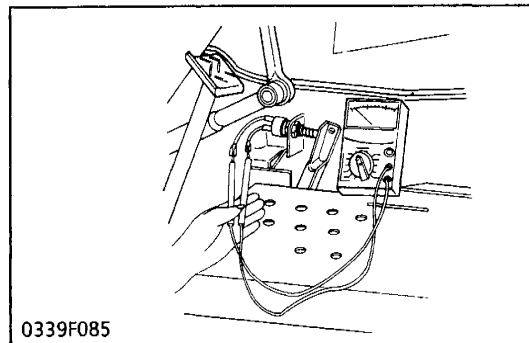

Safety Switch

1. Remove the safety switch leads.
2. Connect the circuit tester to the safety switch leads.
3. Measure the resistance while depressing the clutch pedal.
4. If the safety switch is defective, replace it.

Resistance (Across switch terminal)	When switch push is pushed	0 ohm
	When switch push is released	Infinity

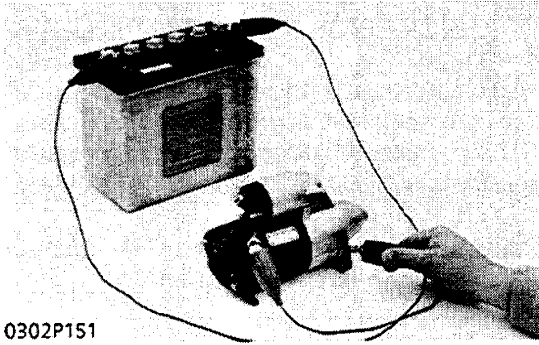
[B1550-B1750-B1550HST-B1750HST]

0302P151

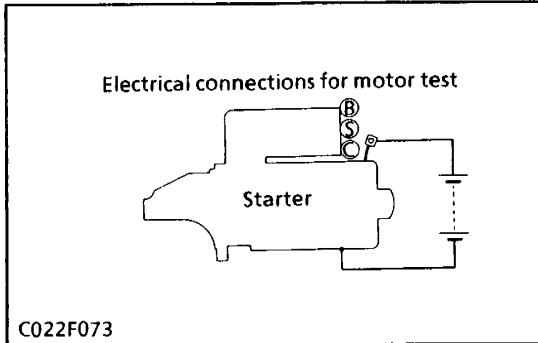

C022F073

Motor Test

1. Disconnect the ground cable from the battery negative terminal post.
2. Disconnect the cable and the leads from the starter.
3. Remove the starter from the engine.
4. Disconnect the connecting lead from the starter's C terminal.
5. Connect a jumper lead from the connecting lead to the battery positive terminal post.
6. Connect a jumper lead momentarily between the battery negative terminal post and the starter body.
7. If the motor does not run, check the motor.

⚠ CAUTION

- Secure the starter to prevent it from jumping up and down while testing the motor.

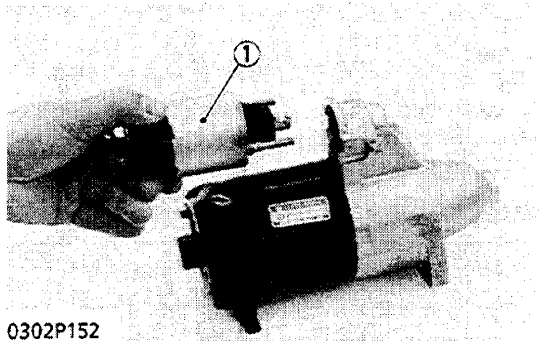
DISASSEMBLING AND ASSEMBLING

0302P152

Magnet Switch

1. Disconnect the connecting lead.
2. Remove the mounting nut.
3. Remove the magnet switch (1) by sliding it up so that it is disconnected from the drive lever.

(1) Magnet Switch

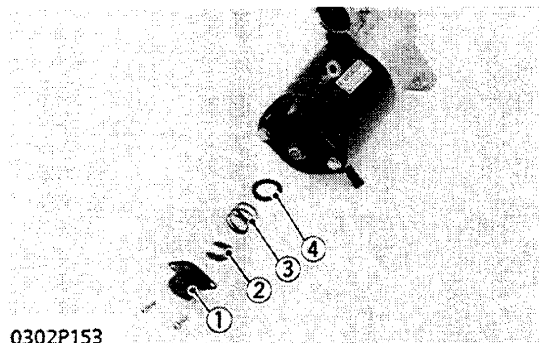

0302P153

Armature Brake

1. Remove the end frame cap(1).
2. Remove the brake shoe (2).
3. Remove the brake spring (3).
4. Remove the gasket (4).

(1) End Frame Cap
(2) Brake Shoe

(3) Brake Spring
(4) Gasket

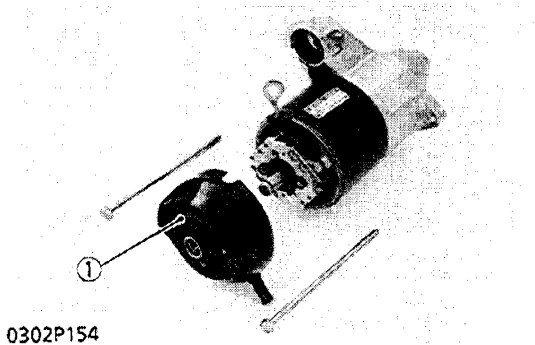

0302P154

End Frame

1. Remove the through bolts.
2. Remove the end frame (1).

(1) End Frame

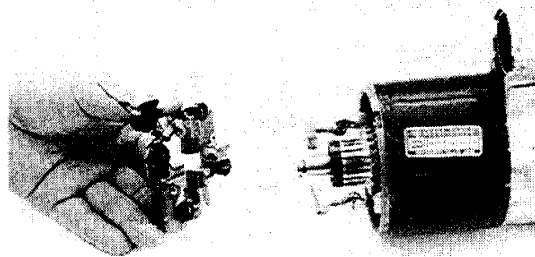

0302P155

Brush Holder

1. Draw out the brush from the holder while holding the spring up.
2. Remove the brush holder.

(When reassembling)

- When replacing the spring, install it by referring to the figure.
- Do not contact the brush's positive lead with the body.

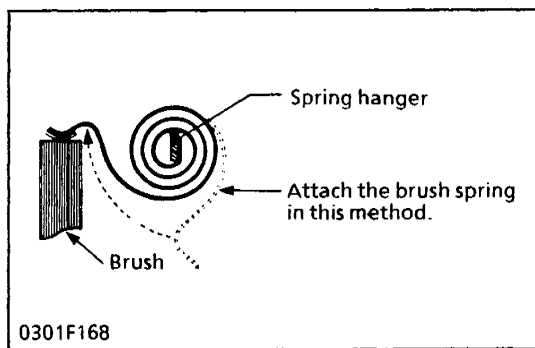

0301F168

Yoke

1. Draw out the yoke (1) from the drive end frame.

(When reassembling)

- Install the Yoke, noting the location of dowel pin.

(1) Yoke

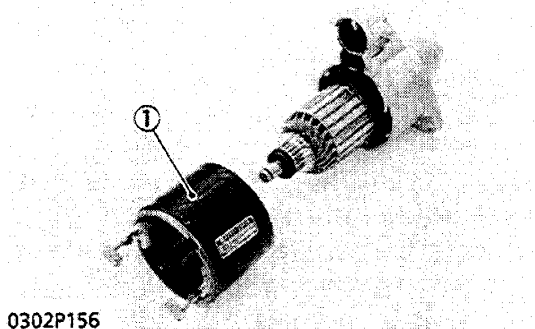

0302P156

Armature

1. Draw out the armature (2) with the drive lever (1).

(When reassembling)

- Install the drive lever, noting its direction.

(1) Drive Lever

(3) Drive End Frame

(2) Armature

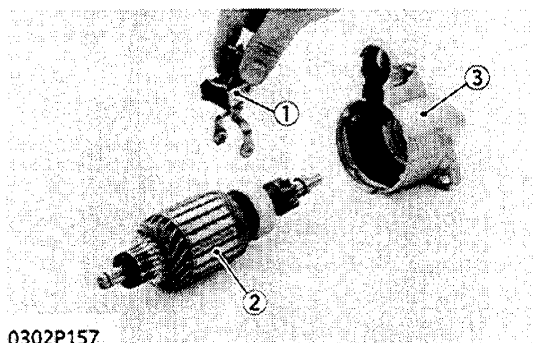

0302P157

SERVICING

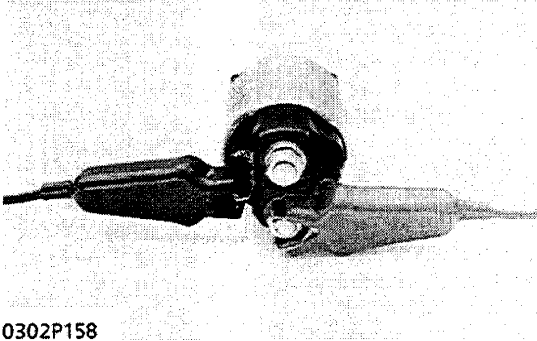

0302P158

Magnet Switch

1) Pull-in (Attraction Test)

1. Apply 1/2 of the rated voltage (approx. 6V) across the S terminal and C terminal.
2. If the plunger is attracted strongly, the pull-in coil is good; if not, it is defective.

Factory specification.... The plunger should be attracted strongly.

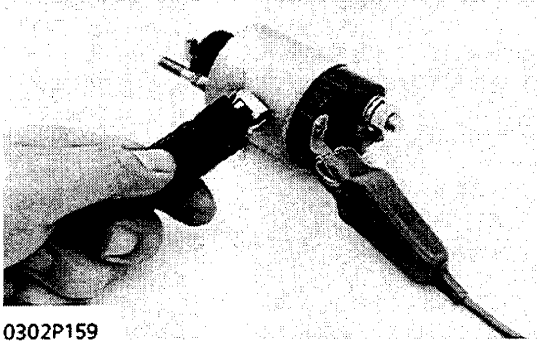

0302P159

2) Holding Coil (Retention Test)

1. Apply 1/2 of the rated voltage (approx. 6V) across the S terminal and the body, push the plunger in by hand, and then release it.
2. If the plunger stays attracted, the holding coil is good; if not, it is defective.

Factory specification.... The plunger remains attracted.

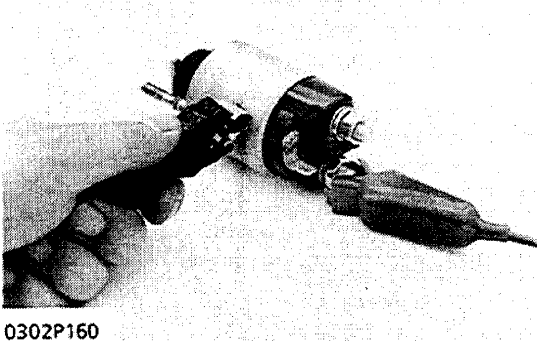

0302P160

3) Plunger Return Stroke

1. Apply the rated voltage (approx. 12V) between C terminal and the body. Push the plunger in by hand, then release the hand.
2. If the plunger returns immediately, it is good; if not, it is defective.

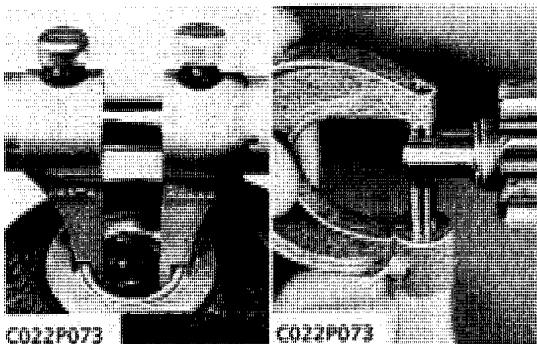

C022P073

C022P073

Clearance between Shaft and Bushing

1. Measure the bushing I.D. on the drive side and the commutator side
2. Measure the shaft O.D. on the drive side and the commutator side, and calculate the clearance.
3. If the clearance exceeds the allowable limit, replace the bushing.

Clearance between shaft and bushing	Factory spec (Commutator side)	0.03 to 0.10 mm 0.012 to 0.0039 in
	Allowable limit	0.2 mm 0.0079 in.
	Factory spec. (Drive side)	0.05 to 0.10 mm 0.0020 to 0.0039 in.
	Allowable limit	0.2 mm 0.0079 in
Shaft O.D.	Factory spec.	12.5 mm 0.4921 in
Drive bushing I.D	Factory spec.	12.55 to 12.60 mm 0.4941 to 0.4961 in.
Commutator bushing I.D.	Factory spec	12.53 to 12.60 mm 0.4933 to 0.4961 in

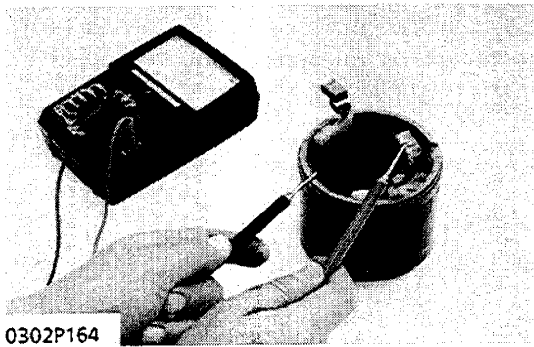

0302P164

Field Coil Breakage

1. Check the conduction across the case and brush with a circuit tester.
2. If either is not conducting, replace it.

Field coil breakage

Factory specification..... Should be conducted.

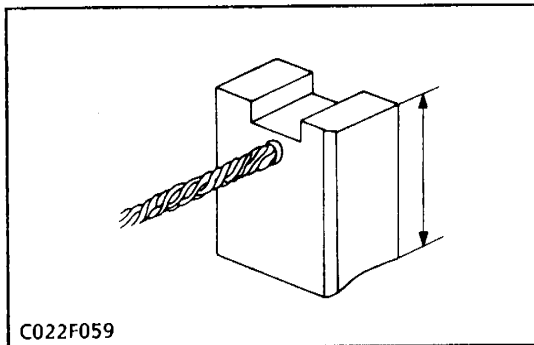

C022F059

Brush Wear

1. Measure the brush length with vernier calipers.
2. If the length is less than the allowable limit, replace it.

Brush length	Factory spec.	16.0 mm 0.6299 in.
	Allowable limit	10.5 mm 0.4134 in.

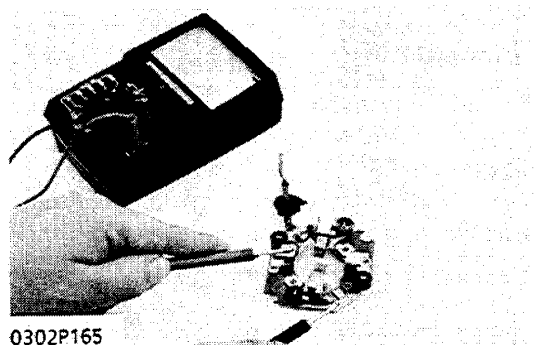

0302P165

Grounding of Brush Holder

1. Check the insulation of the positive brush holder.
2. If the insulation is defective, replace it.

Grounding of brush holder

Factory specification..... Should not be conducted.

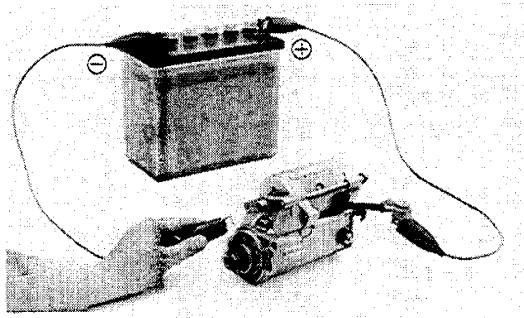
[B2150-B2150HST]

0107P084

Motor Test

1. Disconnect the connecting lead from the "C" terminal of the starter and connect a jumper lead from the connecting lead to the positive battery terminal.
2. Connect a jumper lead momentarily between the starter body and the negative battery terminal.
3. If the motor does not run, check the motor.

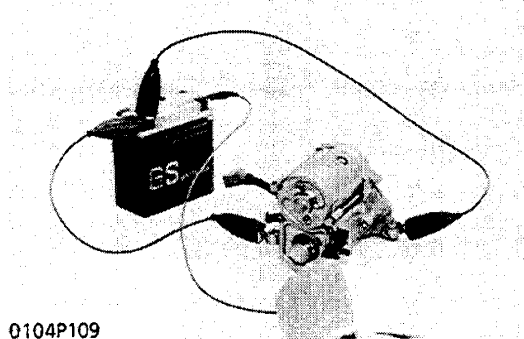

0104P109

Magnet Test

1. Disconnect the connecting lead from the "C" terminal of the starter.
2. Connect jumper leads from the negative terminal of 6 V battery to the body and "C" terminal of the magnet switch.
3. The pinion gear should pop out, when a jumper lead is connected between the positive terminal of the battery to the "S" terminal of the magnet switch.
4. The pinion gear should stay out without the jumper from the negative terminal to the "C" terminal.

■ NOTE

- Each test should be carried out for a short time, about 3 to 5 seconds.

DISASSEMBLING AND ASSEMBLING

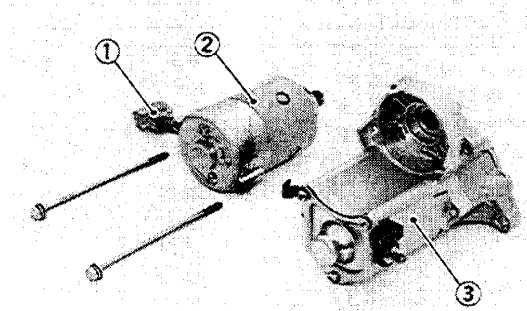

0107P085

Motor

1. Remove the connecting lead (1).
2. Remove the through bolts which tighten the motor (2) and the magnet switch (3).
3. Detach the motor.

(1) Connecting Lead
(2) Motor

(3) Magnet Switch

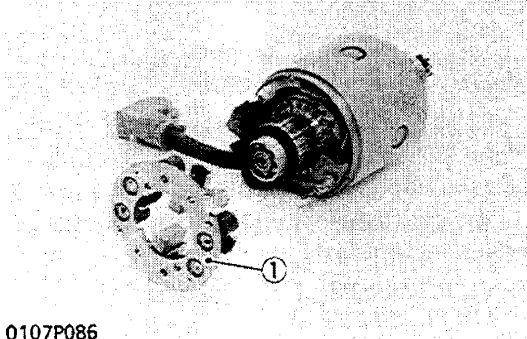

0107P086

Brush Holder

1. Remove the end frame.
2. Draw out the brushes from each holder while lifting the spring up.
3. Remove the brush holder (1).

■ NOTE

- Do not damage the brush, commutator and bearing.

(1) Brush Holder

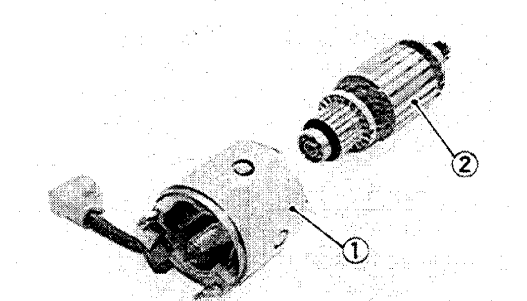

0107P087

Armature

1. Draw out the armature (2) from the yoke (1).

■ NOTE

- Do not damage the bearing and do not let the dust or oil adhere to it.

(1) Yoke

(2) Armature

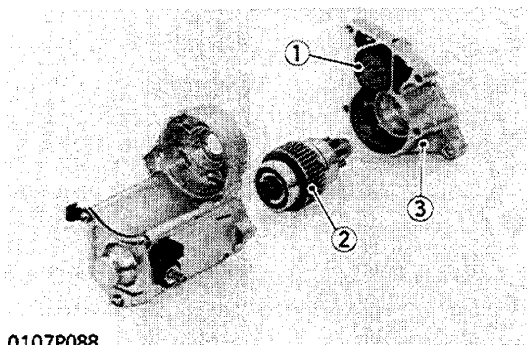

0107P088

Housing, Idle Gear and Clutch

1. Remove the housing (3).
2. Remove the idle gear (1) and the clutch (2).

■ NOTE

- Do not damage the clutch bearing and do not let the dust adhere to it.
- Do not lose the steel ball in the clutch.

(1) Idle Gear
(2) Clutch

(3) Housing

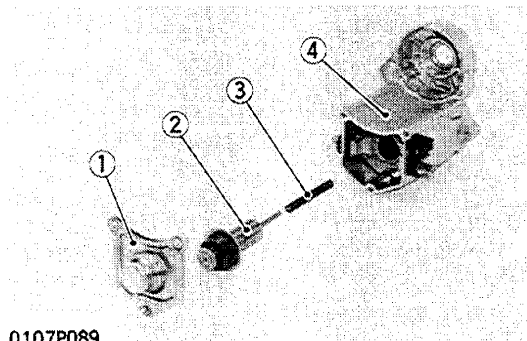

0107P089

Plunger

1. Remove the end cover (1) of magnet switch (4).
2. Remove the plunger (2) and spring (3).

(1) End Cover
(2) Plunger

(3) Spring
(4) Magnet Switch

SERVICING

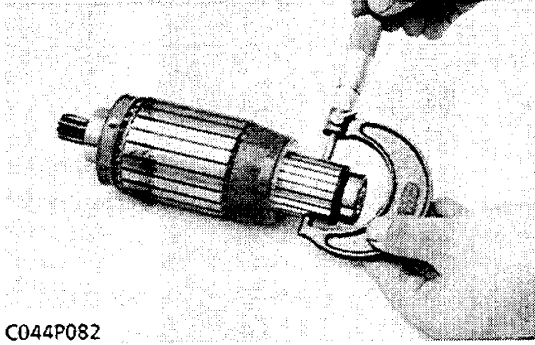

C044P082

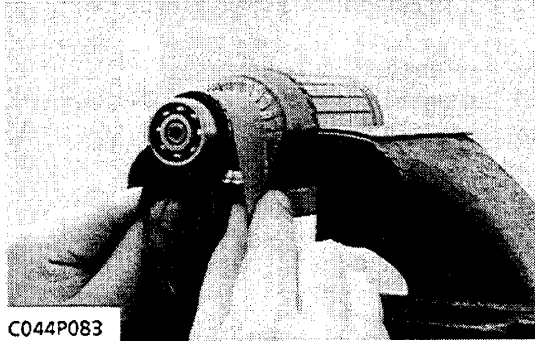

C044P083

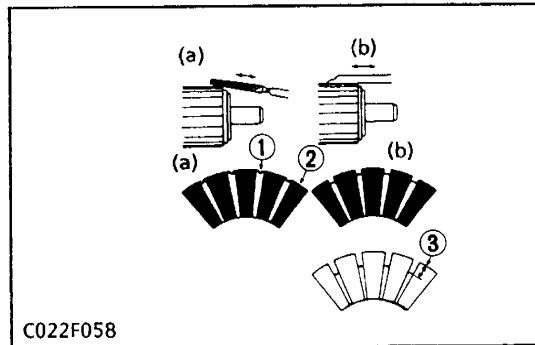

C022F058

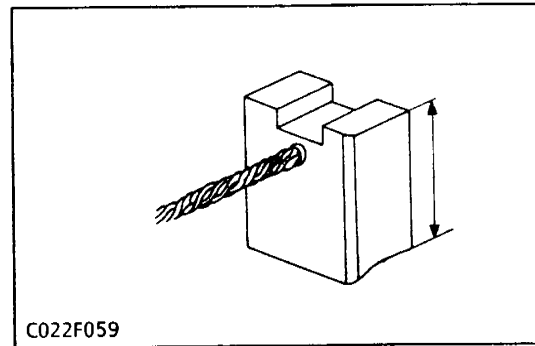

C022F059

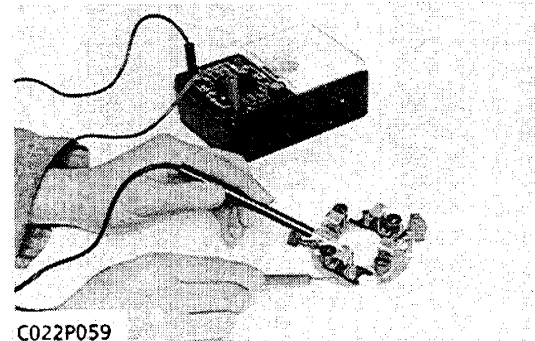

C022P059

Commutator and Mica

1. Check the contact face of the commutator for wear, and grind the commutator with sand paper if it is slightly worn.
2. Measure the commutator O.D. at several points.
3. If the difference of the O.D.'s exceeds the allowable limit, correct the commutator on a lathe to the factory specification.
4. If the minimum O.D. is less than the allowable limit, replace it.
5. Measure the mica undercut.
6. If the undercut is less than the allowable limit, correct with a saw blade and chamfer the segment edges.

Commutator O.D.	Factory spec.	30.0 mm 1.1811 in.
	Allowable limit	29.0 mm 1.1417 in.
Difference of O.D.'s	Factory spec.	Less than 0.1 mm 0.004 in.
	Allowable limit	0.4 mm 0.016 in.
Mica undercut	Factory spec.	0.5 to 0.8 mm 0.020 to 0.031 in.
	Allowable limit	0.2 mm 0.008 in.

- (1) Mica
- (2) Segment
- (3) Depth of Mica
- (a) Bad
- (b) Good

Brush Wear

1. Measure the brush length.
2. If the length is less than the allowable limit, replace it.

Brush length	Factory spec.	13.0 mm 0.512 in.
	Allowable limit	8.5 mm 0.335 in.

Brush Holder

1. Check the continuity across the brush holder and holder support with an ohmmeter.
2. If it conducts, replace it.

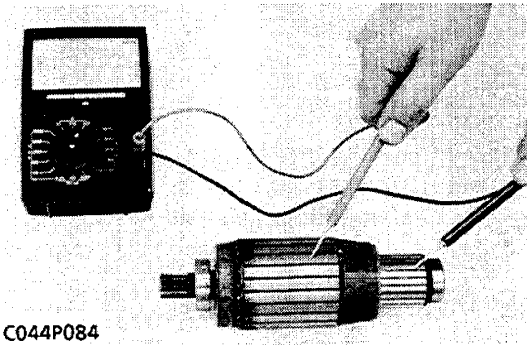

C044P084

Armature Coil

1. Check the continuity across the commutator and armature shaft with an ohmmeter.
2. If it conducts, replace it.

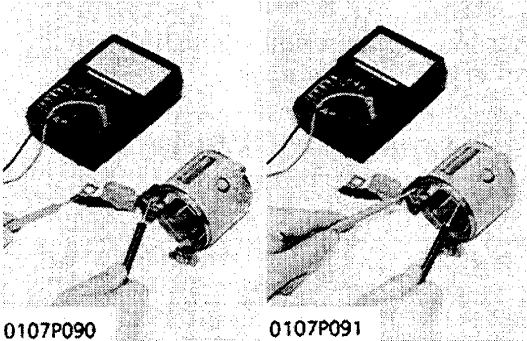

0107P090

0107P091

Field Coil

1. Check the continuity across the lead and brush with an ohmmeter.
2. If it does not conduct, replace them as a unit.
3. Check the continuity across the case and brush.
4. If it conducts, replace them as a unit.

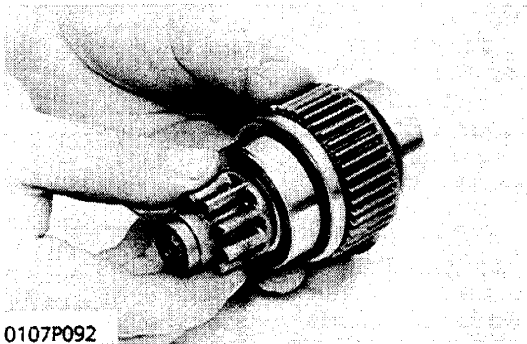

0107P092

Bearing and Clutch

1. Check the bearing and clutch for smooth rotation.
2. The clutch should engage and rotate with the pinion shaft in driving direction and disengage in reverse.

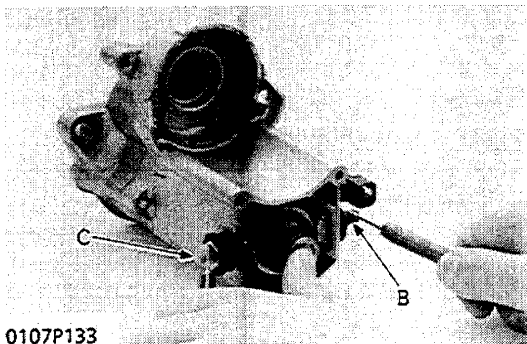

0107P133

Magnet Switch

1. Check the continuity across the "C" terminal and the "B" terminal with an ohmmeter pushing the plunger.
2. If it does not conduct, check the contacts.

[3] ENGINE KEY SWITCH SHUT-OFF SYSTEM

ADJUSTING

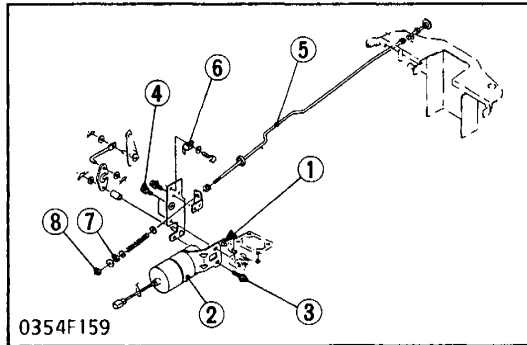

- | | |
|-----------------------------------|------------------|
| (1) Fuel Cut Off Solenoid Plunger | (6) Spring Plate |
| (2) Fuel Cut Off Solenoid | (7) Plain Washer |
| (3) Bolt | (8) Nut |
| (4) Bolt | (9) Stopper Bolt |
| (5) Engine Stop Rod | |

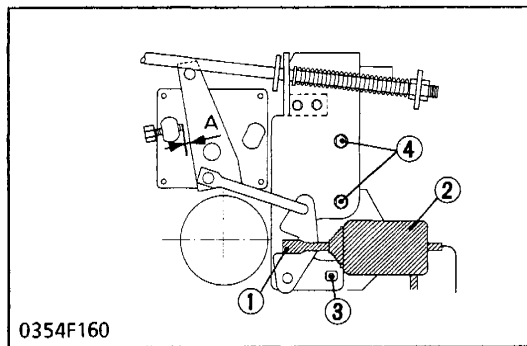
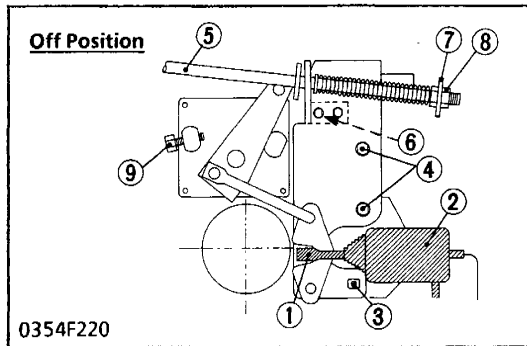

Adjustment 1

1. When the solenoid plunger (1) is attracted completely, adjust the solenoid (2) setting position so that the clearance A (between stopper bolt and lever) is 0 to 3.0 mm (0.118 in.).
2. After adjusting its position, tighten the bolts (3), (4) to fix the solenoid.

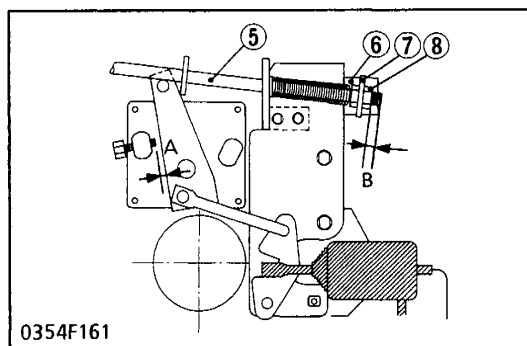

Adjustment 2

1. When strongly pull out the engine stop rod (5), and fix it on the spring plate (6).
2. Adjust the big plain washer (7) position again so that the clearance A is 0 to 3.0 mm (0.118 in.).
3. After adjustment, tighten the lock nut (8).

Distance "B"	Reference value	2 to 5 mm 0.08 to 0.20 in.
--------------	-----------------	-------------------------------

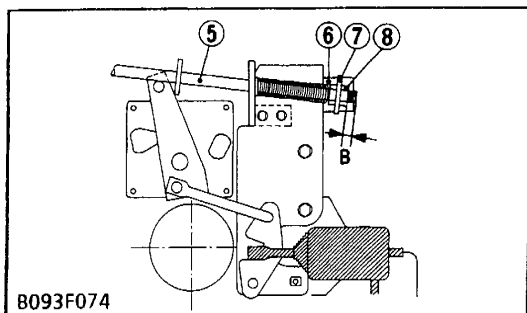

Adjustment (Modified type)

1. As the stopper bolt is not used for the modified models, perform only the adjustment 2.

CHECKING

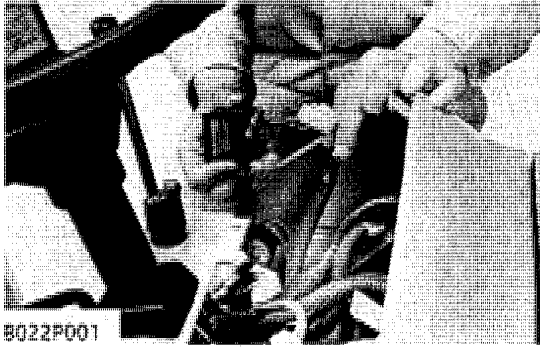

B022P001

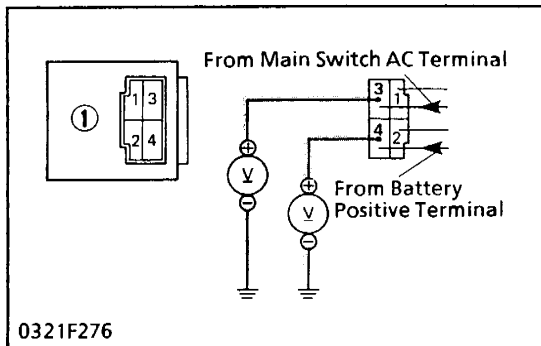

0321F276

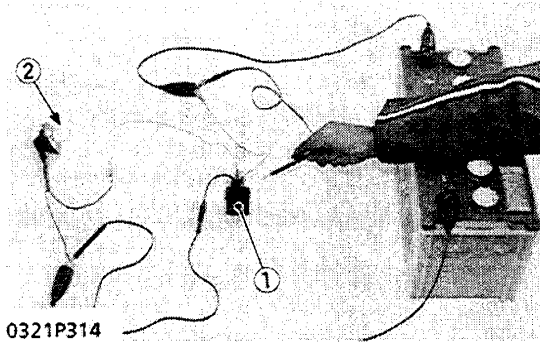

0321P314

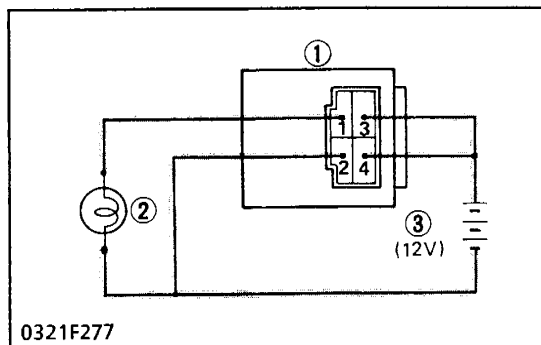

0321F277

Timer Relay

1) Connector Voltage

1. Disconnect the connector from the timer relay after turning the main switch off.
2. Measure the voltage with a voltmeter across the connector 4 terminal and chassis.
3. Turn the main switch on, and measure the voltage across the connector 3 terminal and chassis.
4. If these voltages differ from the battery voltage, the wiring harness or main switch is faulty.

Voltage	Connector 4 terminal - chassis	Approx. battery voltage
	Connector 3 terminal - chassis	

NOTE

- When the timer relay is installed; The timer relay shall be installed with a part of connector down ward. If the timer relay is mounted up-side-down or inclined sideways, water may intrude timer solenoid failure.

2) Test of Timer Relay

1. Remove the timer relay from the tractor.
2. Connect jumper leads across the battery positive terminal and the timer relay 3 terminal, and across the battery positive terminal and the timer relay 4 terminal.
3. Connect jumper leads across the battery negative terminal and the timer relay 2 terminal, and across the battery negative terminal and the bulb terminal.
4. Connect jumper lead across the timer relay 1 terminal and the bulb terminal.
5. The bulb lights up when disconnecting a jumper lead from the 3 terminal and goes off 6 to 13 seconds late, the timer relay is proper.

- (1) Timer Relay
(2) Bulb

- (3) Battery

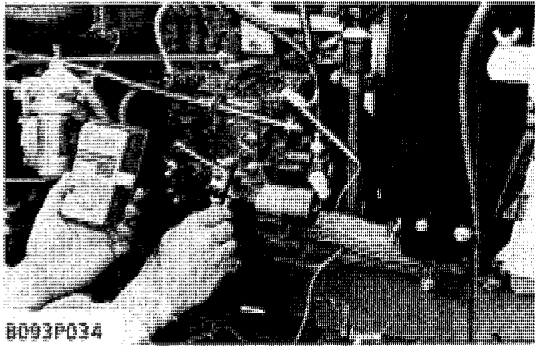

B093P034

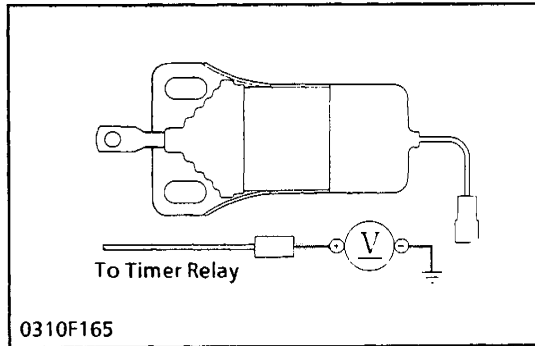

0310F165

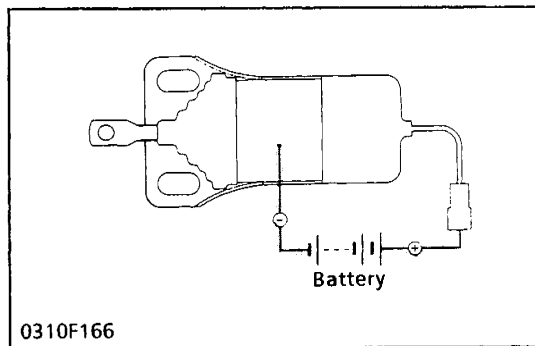

0310F166

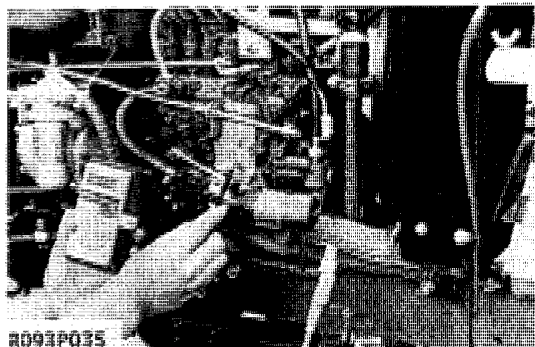

B093P035

Fuel Cut Off Solenoid

1) Lead Terminal Voltage

1. Disconnect the lead from the fuel cut off solenoid after turning the main switch off.
2. Start the engine.
3. Measure the voltage with a voltmeter across the lead terminal of wire harness and the chassis (or solenoid terminal \ominus) just when the main switch is turned off.
4. If correct, 0 voltage is indicated after the battery voltage is indicated for about 10 seconds.
5. If the battery voltage is not indicated for seconds, check the wiring harness, the main switch the timer relay, the regulator, a fuse and the alternator.
6. Connect the lead terminal to solenoid terminal by lead wire and recheck the fuel cut off solenoid operation. And recheck the its operation after starting the engine.

Voltage	Across lead terminal and chassis when main switch turned off	Approx. battery voltage
---------	--	-------------------------

2) Fuel Cut Off Solenoid Test

1. Disconnect the lead from the fuel cut off solenoid after turning the main switch off.
2. Connect jumper leads from the battery positive terminal to the fuel cut off solenoid lead terminal, and from the battery negative terminal to the fuel cut off solenoid body.
3. If the solenoid plunger is not attracted, the fuel cut off solenoid is faulty.

3) Fuel Cut Off Solenoid Resistance

1. Disconnect the lead from the fuel cut off solenoid.
2. Measure the resistance between the fuel cut off solenoid lead terminal and the chassis.

Resistance	Between the fuel cut off lead terminal and the chassis	Approx. 10 Ω
------------	--	---------------------

[4] CHARGING SYSTEM

CHECKING

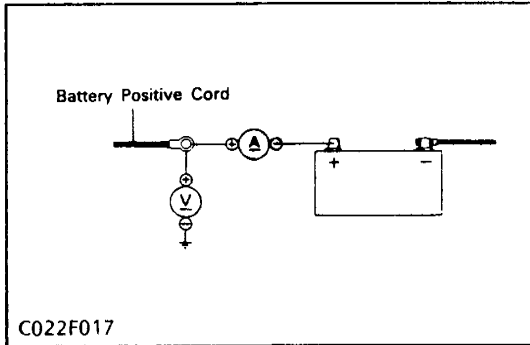

Battery Charging Current

1. After starting the engine, disconnect the battery positive cord (+), and connect an ammeter and voltmeter. Then switch on all electrical loads (such as headlights) and measure the charging current.

■ **NOTE**

- Connect an ammeter only after starting the engine.
- When the electrical loads is considerably low or the battery is fully charged, the specified reading may not be obtained.

Factory spec.	Current	14 to 15A
	Voltage	14 to 15V
	Dynamo speed	5200 r.p.m

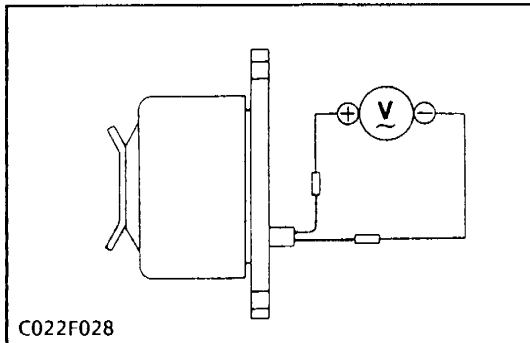

Dynamo No-load Voltage

1. Disconnect the lead wires from the dynamo.
2. Start the engine, and check the generating voltage of the dynamo.

Factory spec.	Voltage	More than AC 20V
	Dynamo speed	5200 r.p.m

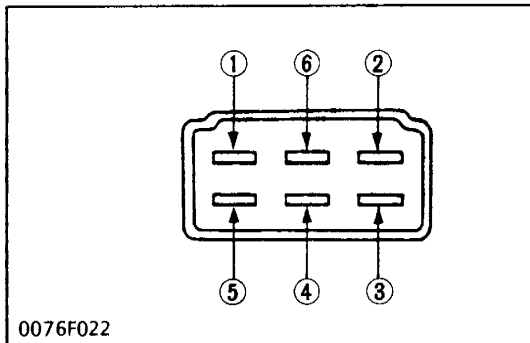

Continuity across Regulator's Terminals

1. Remove the regulator coupler.
2. Check with a tester whether the regulator is in optimum condition or not.

■ **Check Table**

■ **NOTE**

- Type to use a high-resistance tester as far as possible.
- The judgement should be as below table. "ON" if the indicator moves, otherwise "OFF"

- (1) Blue
- (2) Blue
- (3) Red
- (4) Yellow
- (5) Green
- (6) Black

Tester + terminal / Tester - terminal		Cord colours					
		Blue	Blue	Red	Yellow	Green	Black
Cord colours	Blue		OFF	ON	OFF	OFF	OFF
	Blue	OFF		ON	OFF	OFF	OFF
	Red	OFF	OFF		OFF	OFF	OFF
	Yellow	ON	ON	ON		OFF	ON
	Green	OFF	OFF	OFF	OFF		OFF
	Black	OFF	OFF	OFF	OFF	OFF	

[4] CHARGING SYSTEM (Alternator type for Canada)

CHECKING

Alternator

1) Connector Voltage

1. Disconnect the alternator lead and 2P connector from the alternator after turning the main switch off.
2. Measure the voltage across the lead (Red) and the chassis.
3. Turn the main switch to **ON** position and measure the voltage across the 2P connector 2 terminal (RY) and the chassis.
4. If the battery voltage is not indicated, check the main switch or wiring harness.

Voltage	Across connector terminal and chassis	Battery voltage
---------	---------------------------------------	-----------------

(Continued to page S.9-30)

DISASSEMBLING AND ASSEMBLING

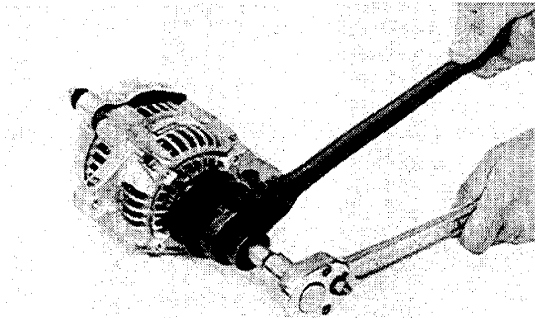

C095P153

Pulley

1. Secure the hexagonal end of the pulley shaft with a double-ended ratchet wrench as shown in the photo, loosen the nut with a socket wrench and remove it.

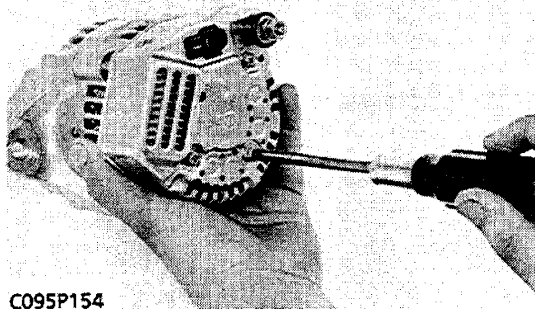

C095P154

Rear End Cover

1. Unscrew three rear end cover screws and the terminal "B" nut and remove the rear end cover.

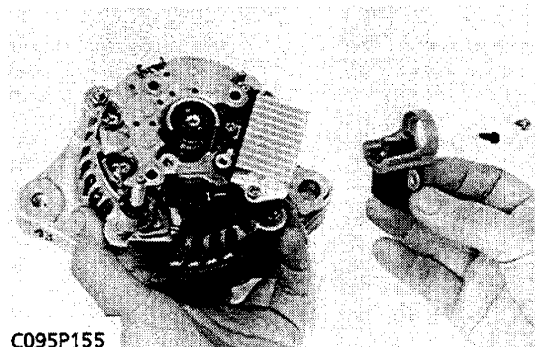

C095P155

Brush Holder

1. Unscrew two screws holding the brush holder and remove the brush holder.

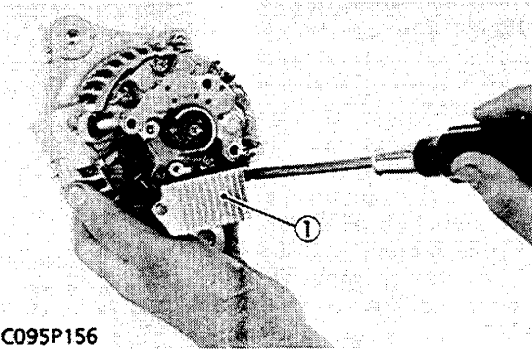

C095P156

IC Regulator

1. Unscrew three screws holding the IC regulator (1) and remove it.

(1) IC Regulator

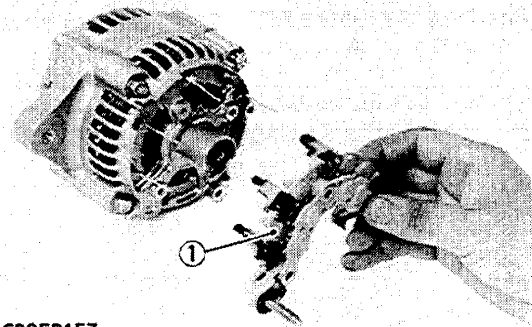

C095P157

Rectifier

1. Remove four screws holding the rectifier (1) and the stator lead wires.

(1) Rectifier

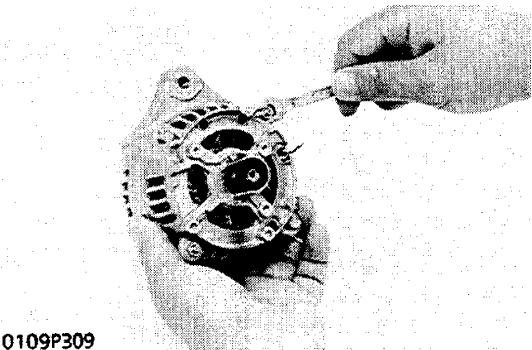

0109P309

Rear End Frame

1. Remove two nuts and two screws holding the drive end frame and the rear end frame.
2. Remove the rear end frame.

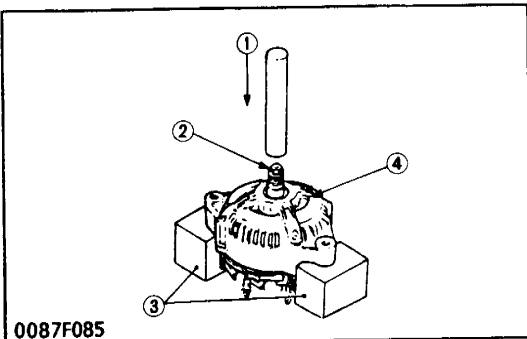

0087F085

Rotor

1. Press out the rotor (2) from drive end frame (4).

■ IMPORTANT

- Take special care not to drop the rotor and damage the slip ring or fan, etc.

(1) Press
(2) Rotor

(3) Block
(4) Drive End Frame

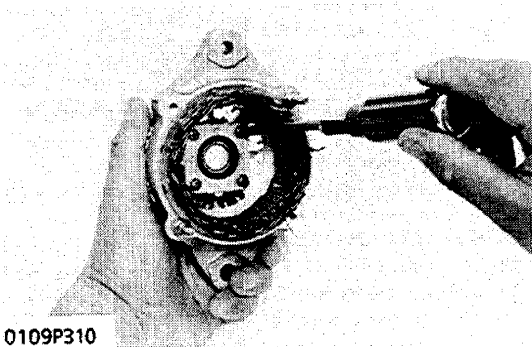

0109P310

Retainer Plate

1. Remove the screws holding the retainer plate and remove the retainer plate.

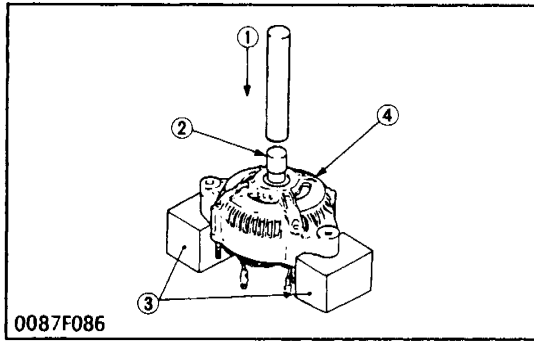

Bearing on the Drive End Side

1. Press out the bearing from drive end frame (4) using with press (1) and jig (2).

- (1) Press
- (2) Jig
- (3) Block
- (4) Drive End Frame

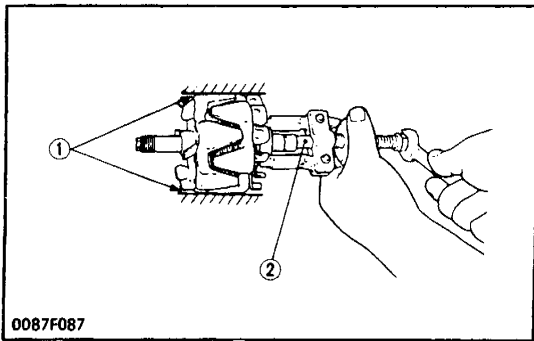

Bearing at the Slip Ring Side

1. Lightly secure the rotor (1) with a vise (2) to prevent damage and remove the bearing using with puller (4).

- (1) Rotor
- (2) Vise
- (3) Bearing
- (4) Puller

SERVICING

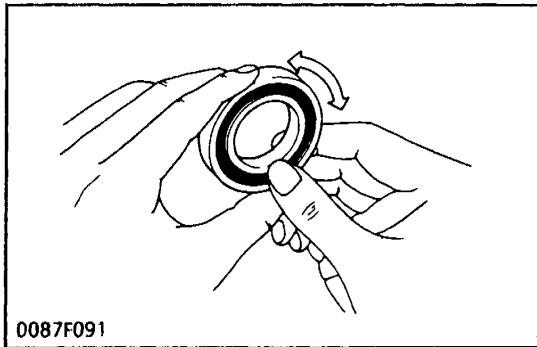

Bearing

1. Check the bearing for smooth rotation.
2. If it does not rotate smoothly, replace it.

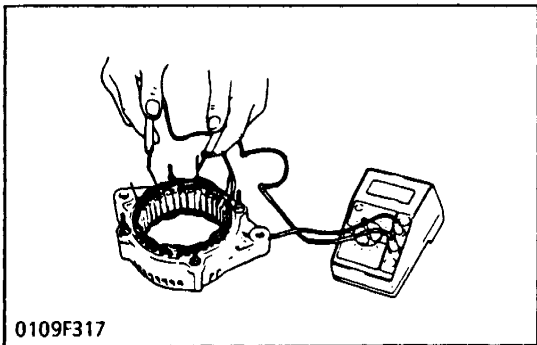

Stator

1. Measure the resistance with an ohmmeter across each lead of the stator coil.
2. If the measurement is not within factory specification, replace it.
3. Check the continuity across each stator coil lead and core with an ohmmeter.
4. If infinity is not indicated, replace it.

Resistance	Factory spec.	Less than 1.0 ohm
------------	---------------	-------------------

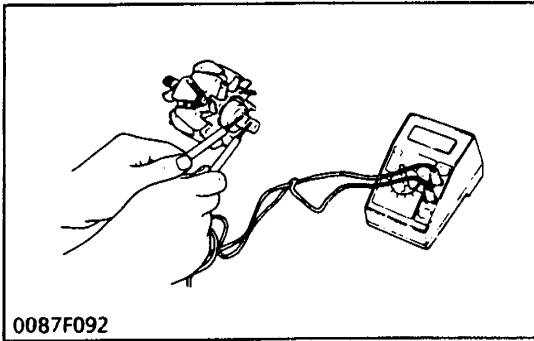

0087F092

Rotor

1. Measure the resistance across the slip rings.
2. If the resistance is not the factory specification, replace it.
3. Check the continuity across the slip ring and core with an ohmmeter.
4. If infinity is not indicated, replace it.

Resistance	Factory spec.	2.9 ohm
------------	---------------	---------

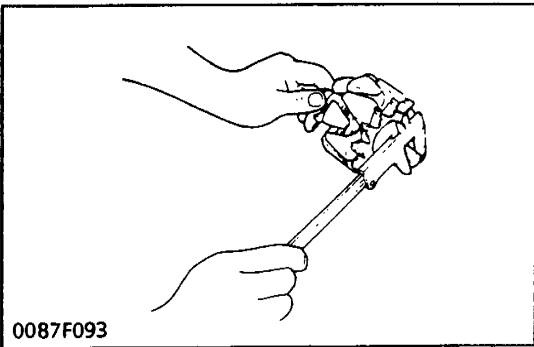

0087F093

Slip Ring

1. Check the slip ring for score.
2. If scored, correct with an sand paper or on a lathe.
3. Measure the outside diameter of slip ring with a vernier caliper.
4. If the measurement exceeds the allowable limit, replace it.

Slip ring O.D.	Factory spec.	14.4 mm 0.57 in.
	Allowable limit	14.0 mm 0.55 in.

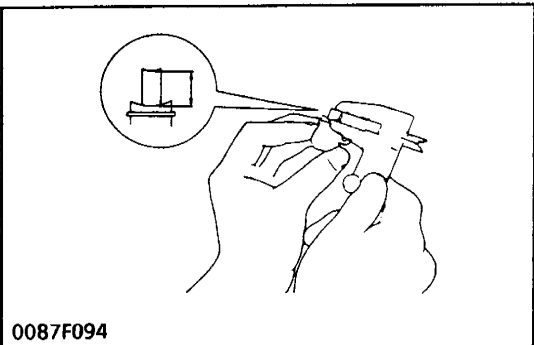

0087F094

Brush Wear

1. Measure the length of brush with a vernier caliper.
2. If the measurement is shorter than allowable limit, replace it.
3. Make sure that the brush moves smoothly.
4. If the brush is defective, replace it.

Brush length	Factory spec.	10.0 mm 0.39 in.
	Allowable limit	1.5 mm 0.059 in.

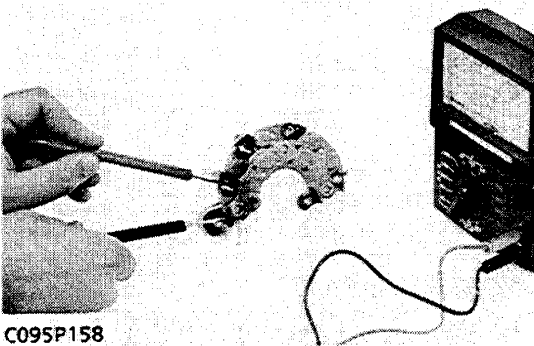

C095P158

Rectifier

1. Check the continuity across each diode of rectifier with an analog ohmmeter. Conduct the test in the (R x 1) setting.
2. The rectifier is normal if the diode in the rectifier conducts in one direction and does not conduct in the reverse direction.

IMPORTANT

- Do not use a 500 V megger for measuring because it will destroy the rectifier.

NOTE

- Do not use an auto digital multimeter. Because it's very hard to check the continuity of rectifier by using it.

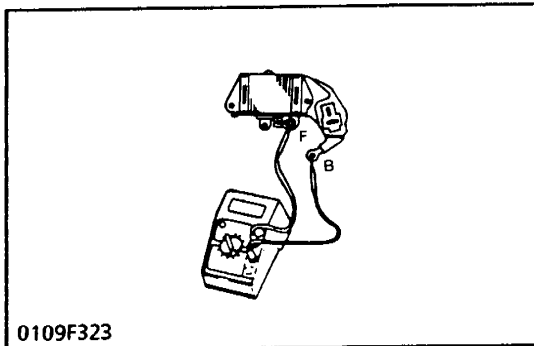

0109F323

IC Regulator

1. Check the continuity across the "B" terminal and the "F" terminal of IC regulator with an analog ohmmeter. Conduct the test in the (R x 1) setting.
2. The IC regulator is normal if the IC regulator conducts in one direction and does not conduct in the reverse direction.

IMPORTANT

- Do not use a 500 V megger for measuring because it will destroy the IC regulator.

NOTE

- Do not use an auto digital multimeter. Because it's very hard to check the continuity of IC regulator by using it.

[5] LIGHTING SYSTEM

CHECKING

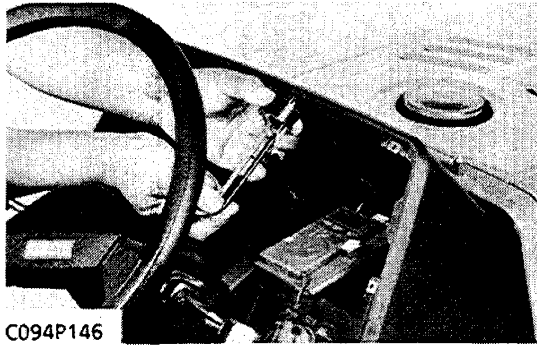

C094P146

Combination Switch

1. Remove the panel board, and disconnect the combination switch connectors after turning the main switch off. Perform the following checkings 1) to 7).

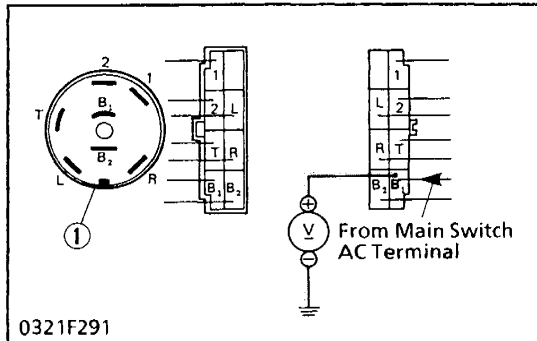

1) Connector Voltage

1. Disconnect the connector from the combination switch after turning the main switch off.
2. Turn the main switch on, and measure the voltage with a voltmeter across the connector **B₁** terminal and the chassis.
3. If the voltage differs from the battery voltage, the wiring harness or main switch is faulty.

Voltage	B₁ - Chassis	Approx. battery voltage
---------	--------------------------------	-------------------------

(1) Combination Switch

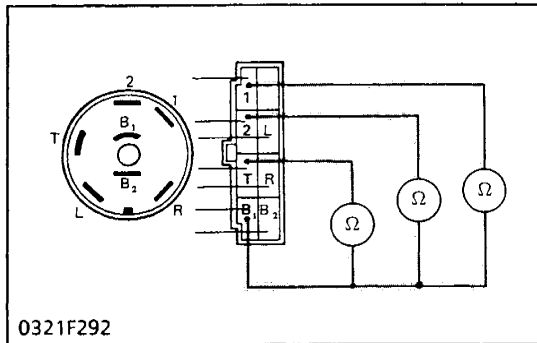

2) Headlight Switch Continuity When Setting Switch Knob at OFF Position

1. Disconnect the connector from the combination switch after turning the main switch off.
2. Set the light switch knob to the **OFF** position.
3. Measure the resistances with an ohmmeter across the **B₁** terminal and 1 terminal, across the **B₁** terminal and 2 terminal, and across the **B₁** terminal and the T terminal.
4. If infinity is not indicated, the combination switch is faulty.

Resistance (Switch knob at OFF position)	B₁ - 1	Infinity
	B₁ - 2	
	B₁ - T	

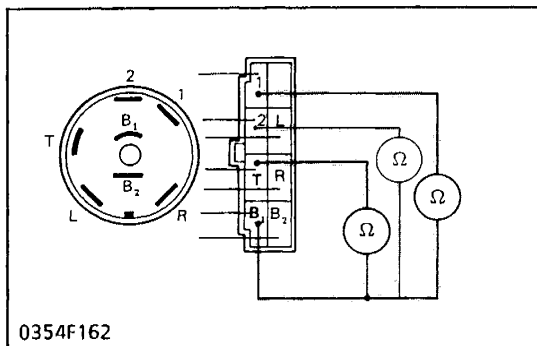

3) Headlight Switch Continuity When Setting Switch Knob at Low-Beam Position

1. Measure the resistance with an ohmmeter across the **B₁** terminal and 2 terminal, and across the **B₁** terminal and T terminal.
2. If 0 ohm is not indicated, the combination switch is faulty.

Resistance (Switch knob at Low-Beam position)	B₁ - 2	0 ohm
	B₁ - T	
	B₁ - 1	Infinity

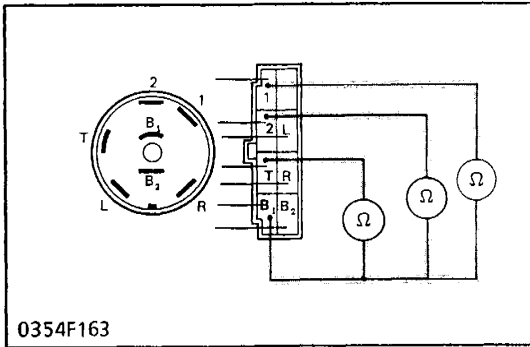

4) Headlight Switch Continuity When Setting Switch Knob at High-Beam Position

1. Measure the resistance with an ohmmeter across the B₁ terminal and 1 terminal, and across the B₁ terminal and T terminal.
2. If 0 ohm is not indicated, the combination switch is faulty.

Resistance (Switch knob at High-Beam position)	B ₁ - 1	0 ohm
	B ₁ - T	
	B ₁ - 2	Infinity

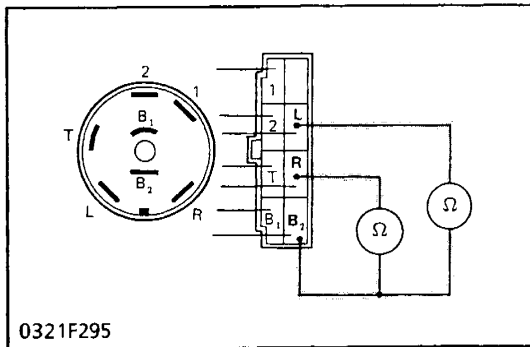

5) Hazard Switch Continuity When Setting Switch Knob at OFF Position

1. Disconnect the connector from the combination switch after turning the main switch off.
2. Set the hazard switch knob to the OFF position.
3. Measure the resistances with an ohmmeter across the B₂ terminal and L terminal, and across B₂ terminal and R terminal.
4. If infinity is not indicated, the combination switch is faulty.

Resistance (Switch knob at OFF position)	B ₂ - L	Infinity
	B ₂ - R	

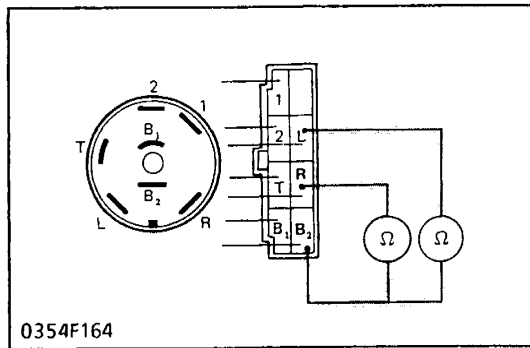

6) Hazard Switch Continuity When Setting Switch Knob at L Position

1. Set the hazard switch knob to the L position.
2. Measure the resistance with an ohmmeter across the B₂ terminal and L terminal.
3. If 0 ohm is not indicated, the combination switch is faulty.

Resistance (Switch knob at L position)	B ₂ - L	0 ohm
	B ₂ - R	Infinity

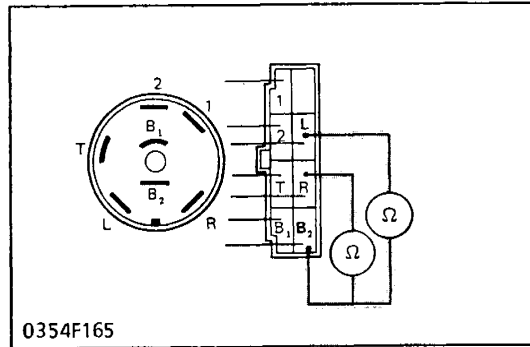

7) Hazard Switch Continuity When Setting Switch Knob at R Position

1. Set the hazard switch knob to the R position.
2. Measure the resistance with an ohmmeter across the B₂ terminal and R terminal.
3. If 0 ohm is not indicated, the combination switch is faulty.

Resistance (Switch knob at R position)	B ₂ - R	0 ohm
	B ₂ - L	Infinity

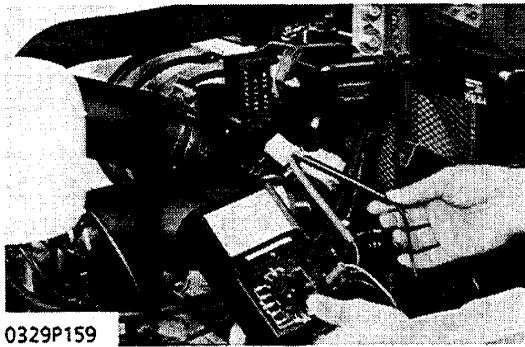

0329P159

Hazard Unit

1) Connector Voltage

1. Disconnect the connector from the hazard unit after turning the main switch off.
2. Turn the main switch on, and measure the voltage with a voltmeter across the connector **B** terminal and **E** terminal.
3. If the voltage differs from the battery voltage, the main switch, fuse or wiring harness is faulty.

Voltage	B - E	Approx. battery voltage
---------	--------------	-------------------------

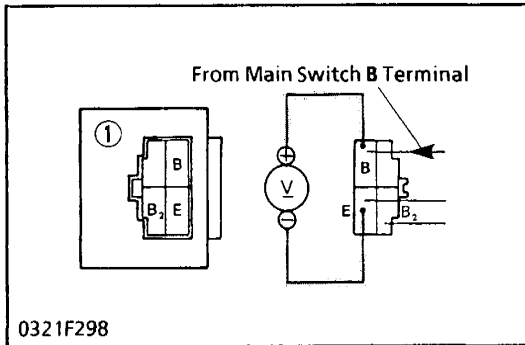

0321F298

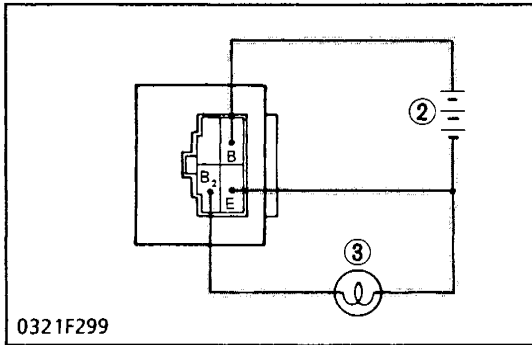

0321F299

- (1) Hazard Unit
- (2) Battery (12V)
- (3) Bulb (25W)

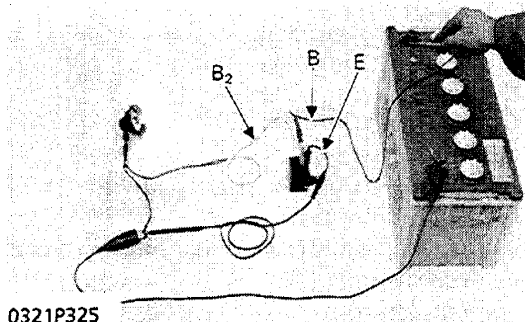

0321P325

2) Hazard Unit Test

1. Remove the hazard unit from the tractor.
2. Connect jumper leads from the **B₂** terminal to the bulb, and from the bulb to the battery negative terminal.
3. Connect jumper lead from the **B** terminal to the battery positive terminal.
4. Connect jumper lead from the **E** terminal to the battery negative terminal.
5. If the bulb does not flicker, the hazard unit is faulty.

[6] EASY CHECKER

CHECKING

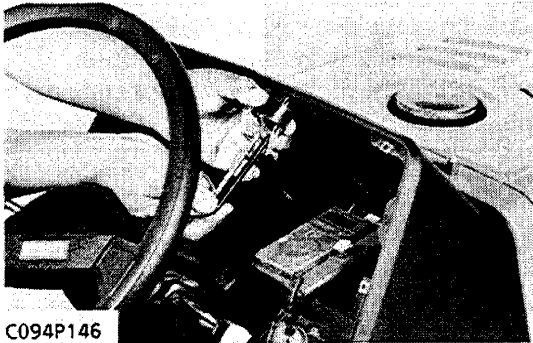

C094P146

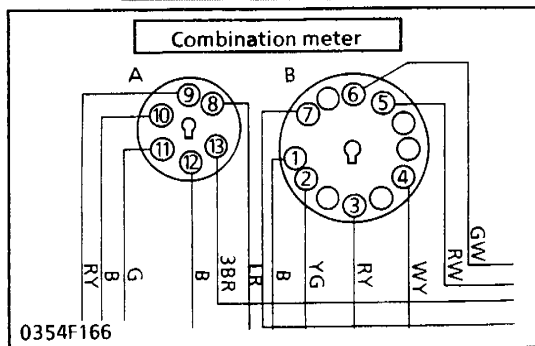

0354F166

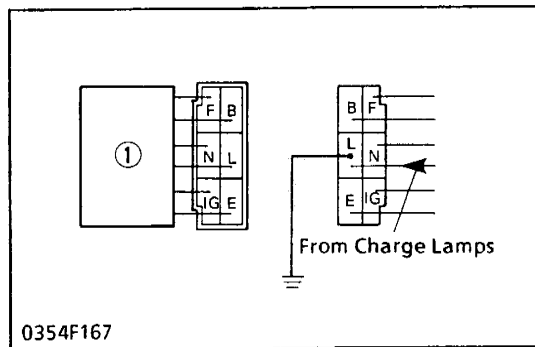

0354F167

Easy Checker

1. After removing the panel board from tractor, disconnect two connectors from it.
2. Turn the main switch on.
3. Measure the voltage with a voltmeter across the B connector terminal (3) (Red-Yellow) and the earth terminal (1) (Black). And also, measure it across the A connector terminal (9) (Red-Yellow) and the earth terminal (10) or (12) (Black).
4. If the voltage differs from the battery voltage, the wiring harness, fuses and main switch should be checked.

(A) Easy Checker

(B) Combination Meter

Charging Circuit (Panel Board and Wiring Harness)

1. Remove the panel board from tractor.
2. Disconnect the 6-P connector from the regulator after turning the main switch off.
3. Turn the main switch on and connect a jumper lead from the wiring harness connector terminal (Green) to the chassis.
4. If the charge lamp does not light, the panel board circuit, regulator, wiring harness, or fuse is fault.

(1) Regulator

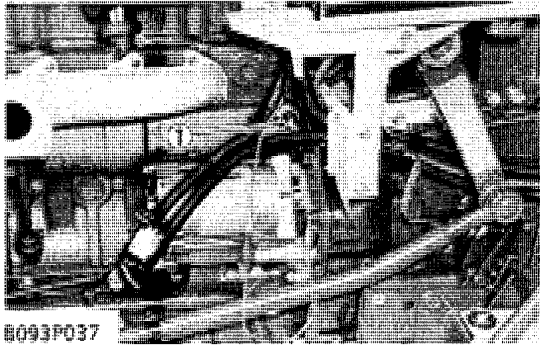

8093F037

Engine Oil Pressure Switch

1) Panel Board and Wiring Harness

1. Disconnect the lead from the engine oil pressure switch after turning the main switch off.
2. Turn the main switch on and connect a jumper lead from the lead terminal to the chassis.
3. If the engine oil pressure indicator lamp does not light, the panel board circuit or the wiring harness is faulty.

(1) Engine Oil Pressure Switch

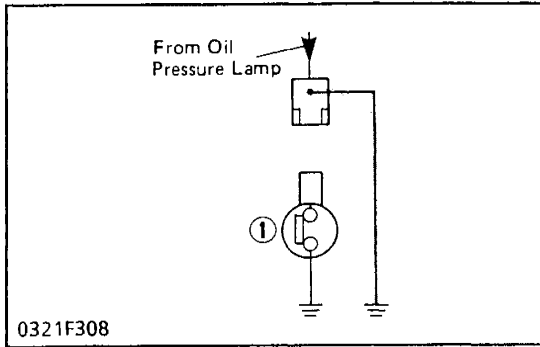

0321F308

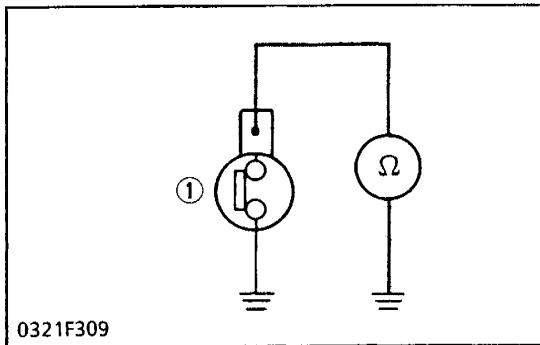

0321F309

2) Switch Continuity

1. Measure the resistance with an ohmmeter across the switch terminal and the chassis.
2. If 0 ohm is not indicated in the normal state, the switch is faulty.
3. If infinity is not indicated at pressure over 4.9 kPa (0.5 kg/cm², 7 psi), the switch is faulty.

Resistance (Switch terminal - Chassis)	In normal state	0 ohm
	At pressure over approx. 4.9 kPa (0.5 kgf/cm ² , 7 psi)	Infinity

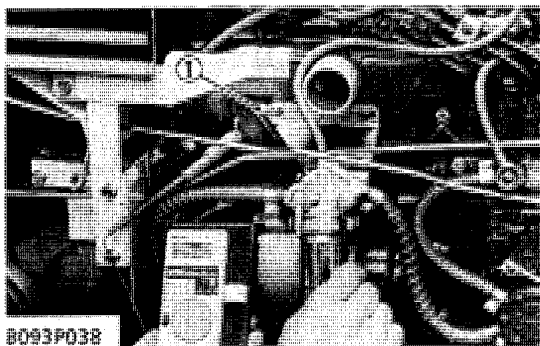

8093F038

Glow Plug

1. Disconnect the lead from the glow plug (1).
2. Connect the tester positive cable to the glow plug lead and negative one to the chassis.
3. Measure its voltage with a voltmeter, after turning the main switch to the preheating or starting position.
4. If its voltage is not approximately the battery one, check the main switch or wiring harness.

(1) Glow Plug

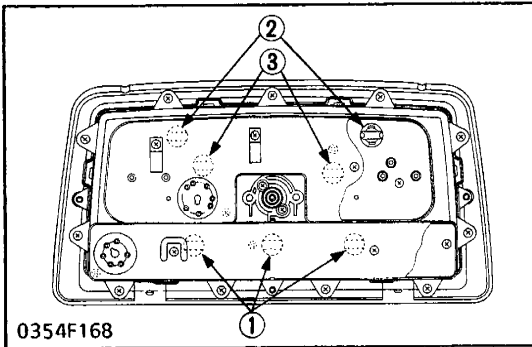

0354F168

- (1) Glow, Engine Oil Pressure, Charge Lamp (from left)
- (2) Pilot Lamp
- (3) Illumination Lamp

Monitor Lamp (for Charge, Engine Oil Pressure and Glow)

1. After removing the panel board from tractor, remove the lower plate behind the panel.
2. Remove the lamp (1).
3. Measure the lamp resistance.
4. If it is infinity, replace the lamp with new.

Lamp spec.	12 V, 3.4 W
------------	-------------

Pilot, Illumination Lamp

1. Remove the upper plate behind the panel.
2. Remove the Lamp (2), (3).
3. Measure the lamp resistance.
4. If it is infinity, replace the lamp.

Lamp spec.	12 V, 3.4 W
------------	-------------

[7] GAUGE CHECKING

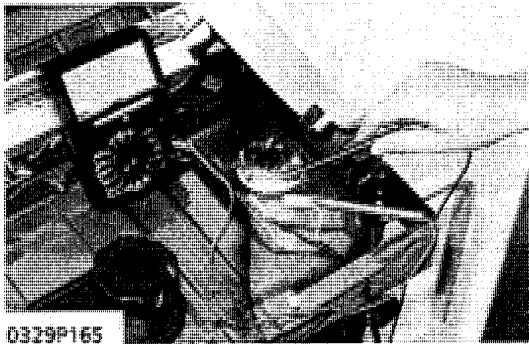

0329P165

Fuel Level Sensor

1) Lead Terminal Voltage

1. Disconnect the connector from the fuel gauge unit after turning the main switch off.
2. Turn the main switch on and measure the voltage with a voltmeter across the connector terminal and the chassis.
3. If the voltage differs from the battery voltage, the wiring harness is faulty.

Voltage	Lead terminal - Chassis	Approx. battery voltage
---------	-------------------------	-------------------------

2) Sensor Continuity

1. Remove the fuel level sensor from the fuel tank.
2. Measure the resistance with an ohmmeter across the sensor terminal and its body.
3. If the reference values are not indicated, the sensor is faulty.

Resistance (Sensor terminal - its body)	Reference value	Float at uppermost position	1 to 5 ohms
		Float at lowermost position	103 to 107 ohms

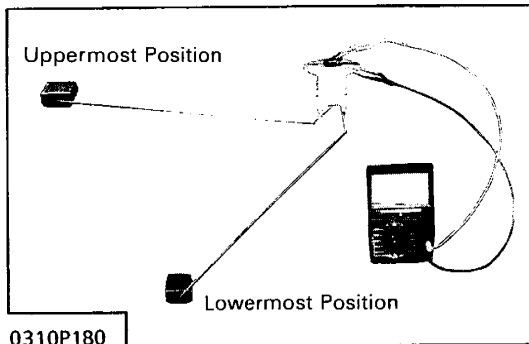

0310P180

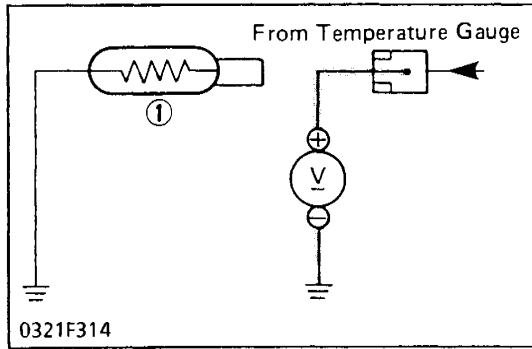

Coolant Temperature Sensor

1) Lead Terminal Voltage

1. Disconnect the lead from the coolant temperature sensor after turning the main switch off.
2. Turn the main switch on and measure the voltage with a voltmeter across the lead terminal and the chassis.
3. If the voltage differs from the battery voltage, the wiring harness, fuse or coolant temperature gauge is faulty.

Voltage	Lead terminal – Chassis	Approx. battery voltage
---------	-------------------------	-------------------------

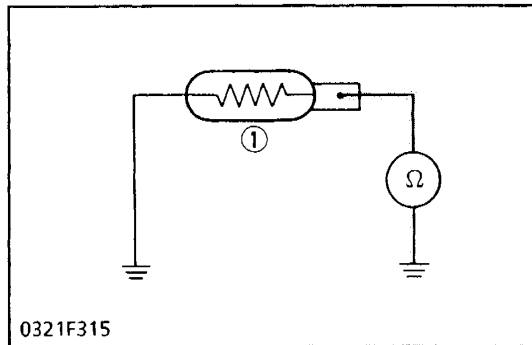

2) Sensor Continuity

1. Measure the resistances with an ohmmeter across the sensor terminal and the chassis.
2. If the reference value is not indicated, the sensor is faulty.

Resistance (Sensor terminal – Chassis)	Reference value	Approx. 12.2 ohms at 130°C (266°F)	Approx. 23.6 ohms at 105°C (221°F)	Approx. 51.9 ohms at 80°C (176°F)	Approx. 153.9 ohms at 50°C (122°F)
--	-----------------	------------------------------------	------------------------------------	-----------------------------------	------------------------------------

(1) Coolant Temperature Sensor

Fuel Gauge, Coolant Temperature Gauge

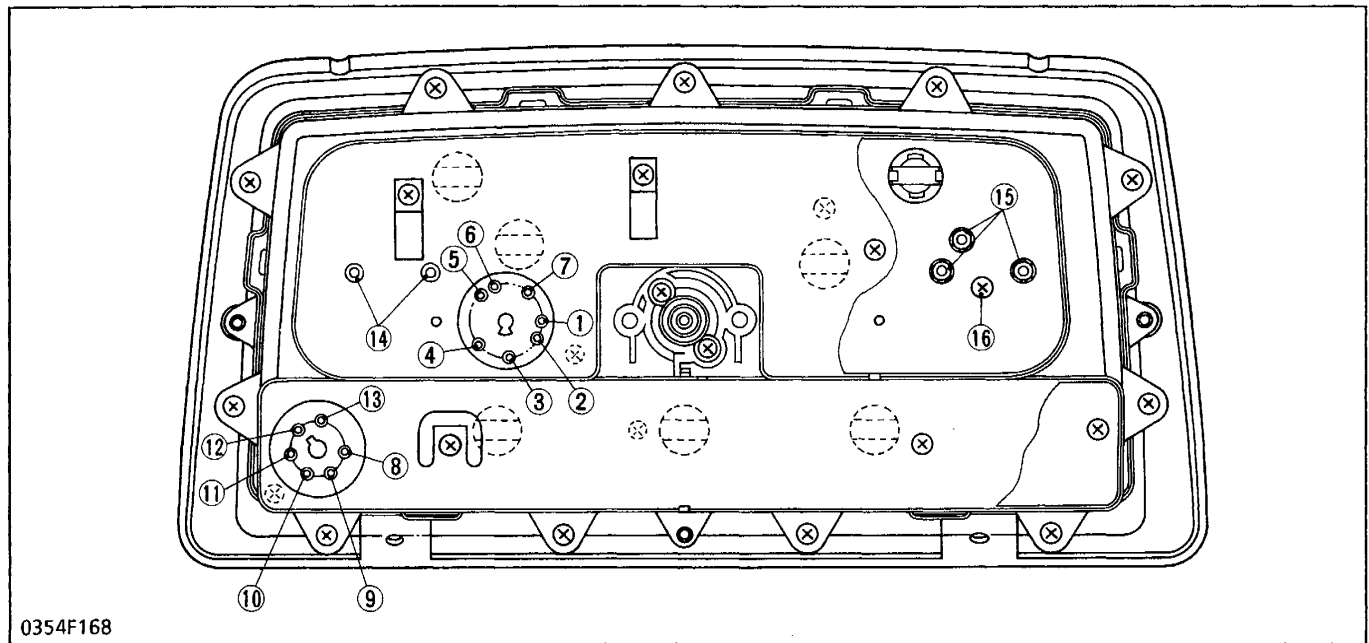

- | | | | |
|------------------------------------|----------------------------------|---------------------|---------------------------------------|
| (1) GND [B] | (5) Right Pilot [RW] | (10) Charge (-) [B] | (14) Coolant Temp. Gauge Setting Nuts |
| (2) Fuel Gauge [YG] | (6) Left Pilot [GW] | (11) Charge (+) [B] | (15) Fuel Gauge Setting Nuts |
| (3) IGN [BY] | (7) Illumination [Y] | (12) Glow (-) [B] | (16) Earth Screw |
| (4) Coolant Temperature Gauge [WY] | (8) Engine Oil Pressure (-) [LR] | (13) Glow (+) [3BR] | |
| | (9) Engine Oil Pressure (+) [RY] | | |

1. Remove the panel board from the tractor.
2. Measure the resistances with an ohmmeter across the FU terminal (2) and GND (1) terminal.
3. If the reference values are not indicated, the fuel gauge is faulty.
4. Measure the resistances with an ohmmeter across the TU (4) terminal and IGN (3) terminal.
5. If the reference values are not indicated, the coolant temperature gauge is faulty.

Fuel Gauge			
Resistance	Reference value	FU – GND	Approx. 125Ω

Coolant Temperature Gauge			
Resistance	Reference value	TU – IG	Approx. 55Ω

(Continued from page S.9-22-1)

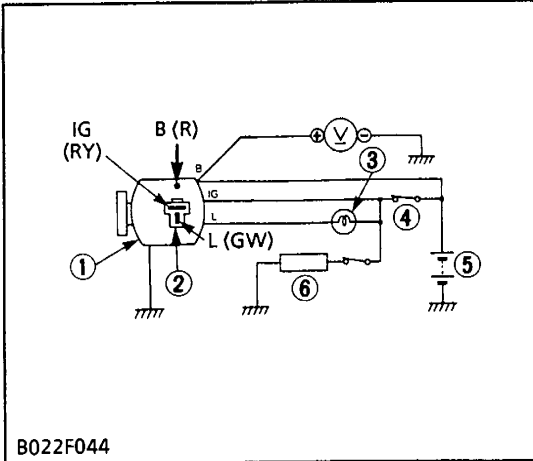

- (1) Alternator
- (2) Alternator 2P Connector
- (3) Bulb
- (4) Main Switch
- (5) Battery
- (6) Load

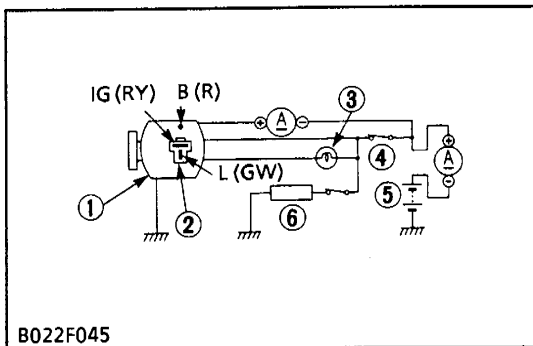

- (1) Alternator
- (2) Alternator 2P Connector
- (3) Bulb
- (4) Main Switch
- (5) Battery
- (6) Load

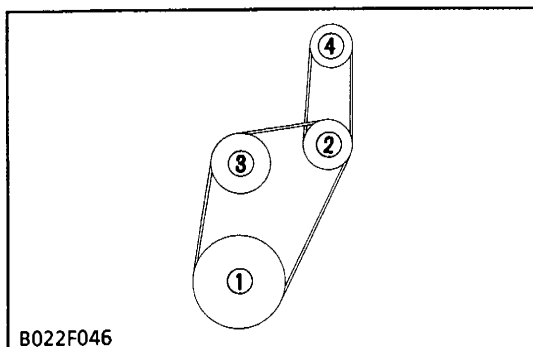

- (1) Crankshaft Pulley
- (2) Tension Pulley
- (3) Cooling Fan Pulley
- (4) Alternator Pulley

2) No-Load Test

1. Disconnect the connector (2) from the alternator.
2. Connect the leads with the terminals as shown in the figures.
3. Start the engine and set its speed approx. 2250 rpm.
4. Disconnect the battery \ominus cord from the battery (5).
5. Measure the voltage across the alternator B terminal and the chassis.
6. If the measurement is less than the factory specification, disassemble the alternator and check the IC regulator.

Voltage	Factory spec.	14.2 to 14.8 V (at 25°C)
---------	---------------	--------------------------

(Reference)

- Once the engine has started, the alternator temperature rises quickly up to an ambient temperature of 70~90°C. As the temperature goes higher than 50°C, the alternator voltage slowly drops; at higher than 100°C, it drops by about 1 V.

3) Output Current

1. Light up the headlight and work light.
2. Set the engine speed at approx. 2250 rpm, and measure the output current.
3. If the measurement is less than the factory specification, the alternator is defective.

Output current	Factory spec.	More than 43 A
----------------	---------------	----------------

4. Run the engine at idling speed (low rpm) to see if the ammeter reads a negative (-) value (discharge). Then increase the engine rpm to make sure the ammeter reads a positive (+) value (charge).

(Reference)

- Pulley revolution

Engine Pulley		Rated revolution	2250 rpm	Idling speed	
(1) (rpm)	40 A Alt.	2600	2250	B1550-B1750	920~1100
				B2150	950~1050
(4) (rpm)	40 A Alt.	5780	5000	B1550-B1750	2040~2440
				B2150	2110~2330

TO THE READER

In this section, the altered points of New HYDROSTATIC TRANSMISSION from the previous HST are explained separately in two items, "Mechanism" and "Servicing".

The serial number of tractors, new HST has been affected, is as follows.

B1550HST (2WD)	above 20001
B1550HST (4WD)	above 60001
B1750HST (2WD)	above 20001
B1750HST (4WD)	above 60001

As for the items which are not explained in this section, refer to Workshop Manual for B1550·B1550HST·B1750·B1750HST·B2150·B2150HST.

All information, illustrations and specifications contained in this manual are based on the latest production information available at the time of publication.

The right is reserved to make changes in all information at any time without notice.

July '89

© KUBOTA Corporation 1993

CONTENTS

MECHANISM

3 TRANSMISSION	BM.3-1
[1] TRAVELING SYSTEM	BM.3-1
(2) Hydrostatic Transmission	BM.3-1

SERVICING

3 TRANSMISSION	BS.3-1
SERVICING SPECIFICATIONS	BS.3-1
TIGHTENING TORQUES	BS.3-2
CHECKING, DISASSEMBLING AND SERVICING	BS.3-3
[1] SPEED SET DEVICE (B1550HST-1750HST)	
DISASSEMBLING AND ASSEMBLING	BS.3-3
[2] HYDROSTATIC TRANSMISSION	
CHECKING AND ADJUSTING	BS.3-4
DISASSEMBLING AND ASSEMBLING	BS.3-8
SERVICING	BS.3-12

3 TRANSMISSION

[1] TRAVELING SYSTEM (2) Hydrostatic Transmission

■ NOTE

- Tractor serial number B1550HST-E above 20001
- B1550HST-D above 60001
- B1750HST-E above 20001
- B1750HST-D above 60001

■ B1550HST-B1750HST

1. Structure

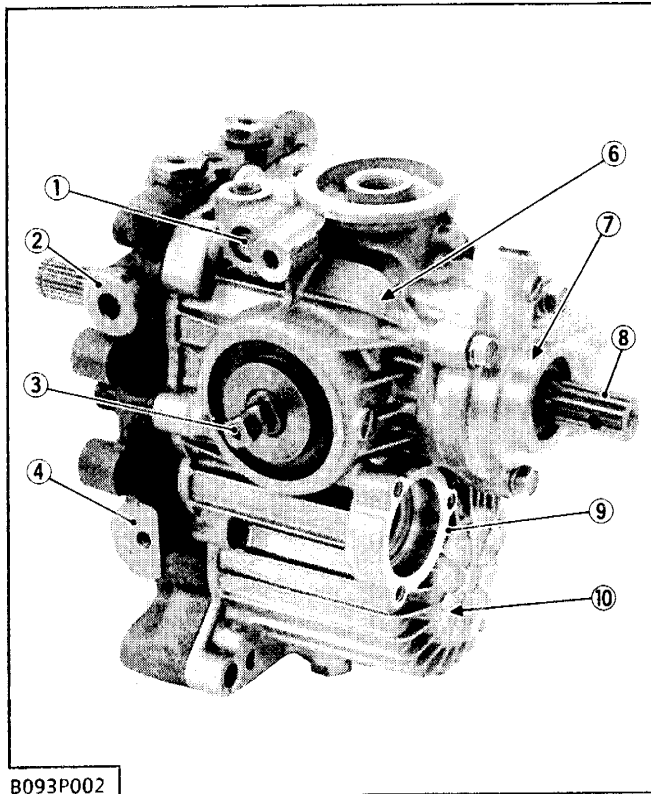

B093P002

- (1) Charge Relief Valve
- (2) Check and High Pressure Relief Valve
- (3) Trunnion Shaft
- (4) Port Block
- (5) Neutral Valve

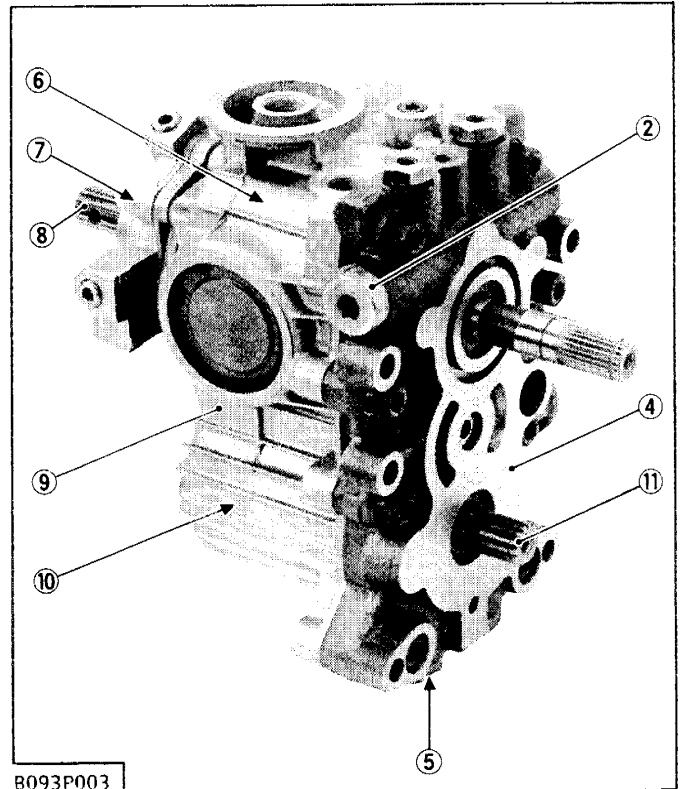

B093P003

- (6) Variable Displacement Piston Pump
- (7) Charge Pump
- (8) Input Shaft
- (9) Case
- (10) Fixed Displacement Piston Motor
- (11) Output Shaft

Hydrostatic transmission is composed of a variable displacement piston pump, fixed displacement piston motor, charge pump and valve system.

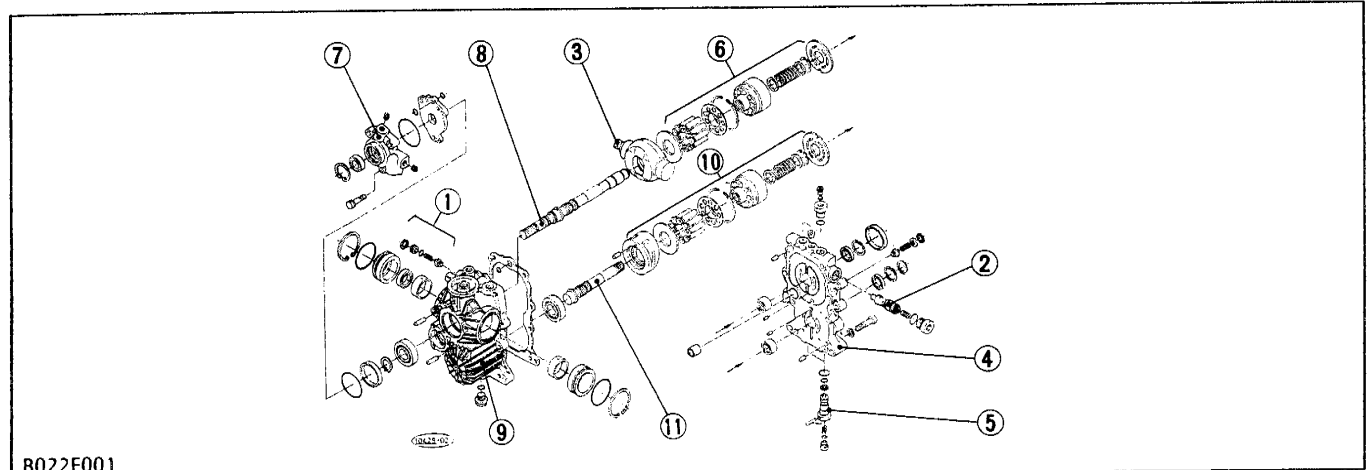

B022F001

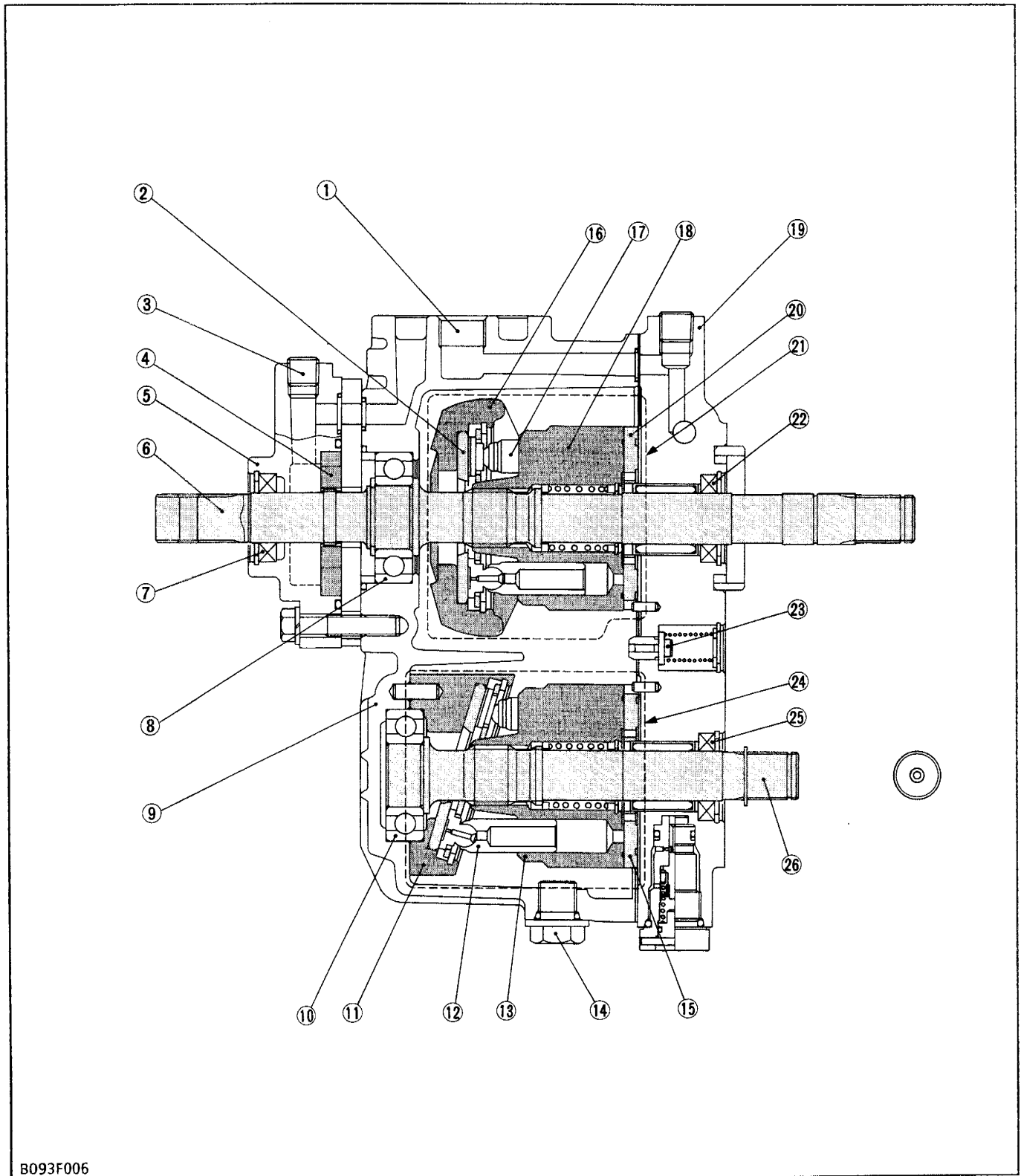

B093F006

- | | | | |
|-----------------------------|-----------------------|--|--------------------------------------|
| (1) Oil Outlet | (8) Ball Bearing | (16) Variable Swashplate | (22) Oil Seal |
| (2) Thrust Plate | (9) Case | (17) Piston | (23) Case Relief Valve |
| (3) P3 Port | (10) Ball Bearing | (18) Cylinder Block | (24) Fixed Displacement Piston Motor |
| (4) Trochoid Rotor Assembly | (11) Fixed Swashplate | (19) Port Block | (25) Oil Seal |
| (5) Charge Pump Case | (12) Piston | (20) Valve Plate | (26) Output Shaft |
| (6) Input Shaft | (13) Cylinder Block | (21) Variable Displacement Piston Pump | |
| (7) Oil Seal | (14) Drain Plug | | |
| | (15) Valve Plate | | |

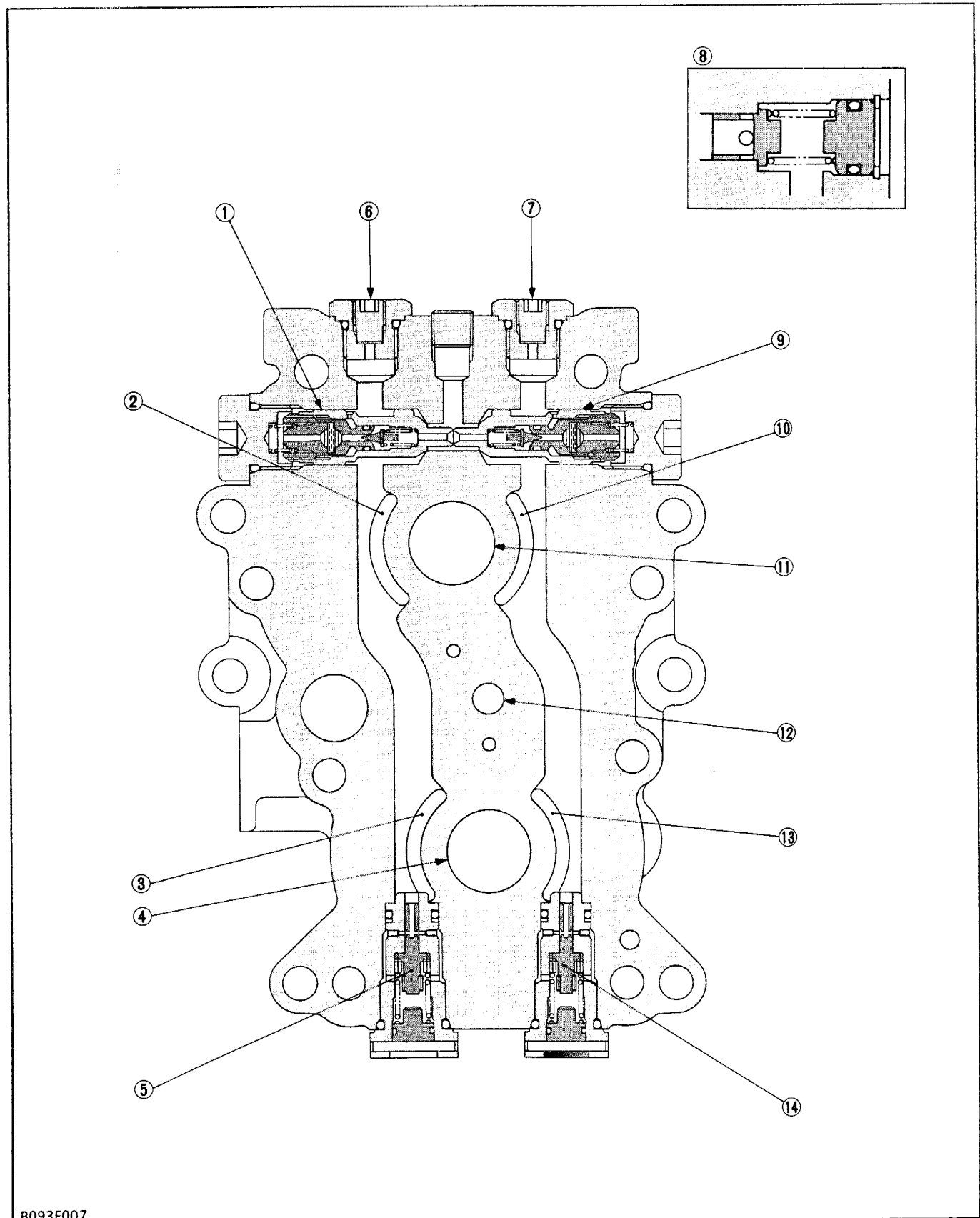

B093F007

- | | | | |
|--|-----------------------------|--|------------------------------|
| (1) Check and High Pressure Relief Valve (Forward) | (4) Output Shaft | (8) Charge Relief Valve | (11) Input Shaft |
| (2) Pump Kidney Port A | (5) Neutral Valve (Forward) | (9) Check and High Pressure Relief Valve (Reverse) | (12) Case Relief Valve |
| (3) Motor Kidney Port C | (6) P1 Port | (10) Pump Kidney Port B | (13) Motor Kidney Port D |
| | (7) P2 Port | | (14) Neutral Valve (Reverse) |

2. Pump and Motor

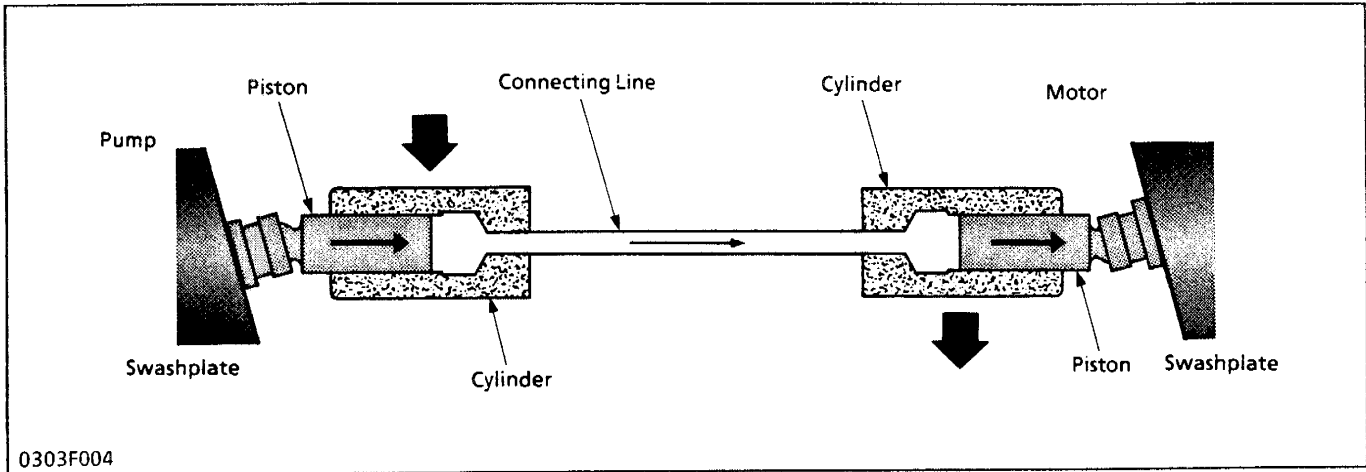

Pump and motor cylinder, each containing pistons, are connected by lines. Cylinders and lines are filled with oil. Pistons ride against swashplates located in pump and motor.

In the pump, as the cylinder rotates, pistons move across the sloping face of swashplate and slide in or out of their cylinder bores.

The oil, forced out by the pump pistons, causes the motor pistons to slide out of their cylinder bores. In the motor, sliding out of the cylinder and moving across the sloping face of swashplate, the pistons rotate the cylinder.

3. Variable Swashplate

This pump is variable displacement one. The angle of its swashplate can be varied so that the volume and pressure of oil pumped by the pistons can be changed or the direction of oil flow can be reversed. The swashplate is moved around the trunnion shaft with the neutral holder, by stepping on the speed control pedal linked to the neutral holder.

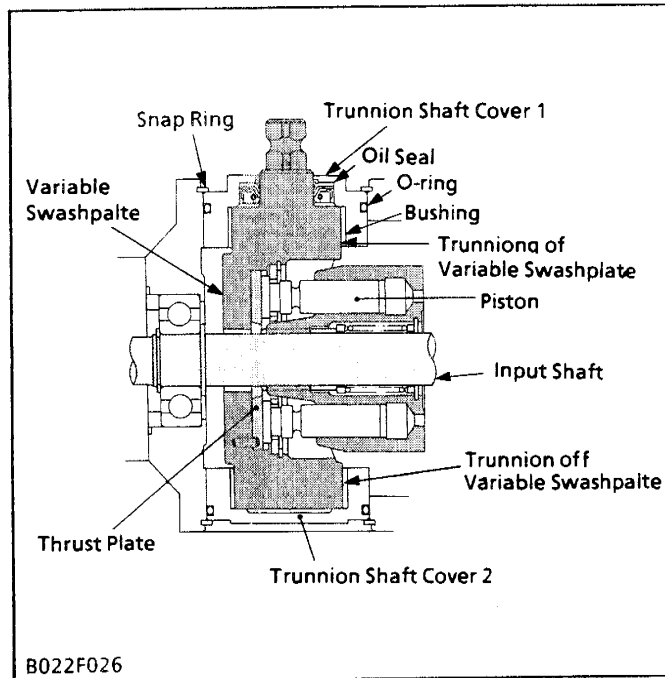

4. Oil Flow and Valves

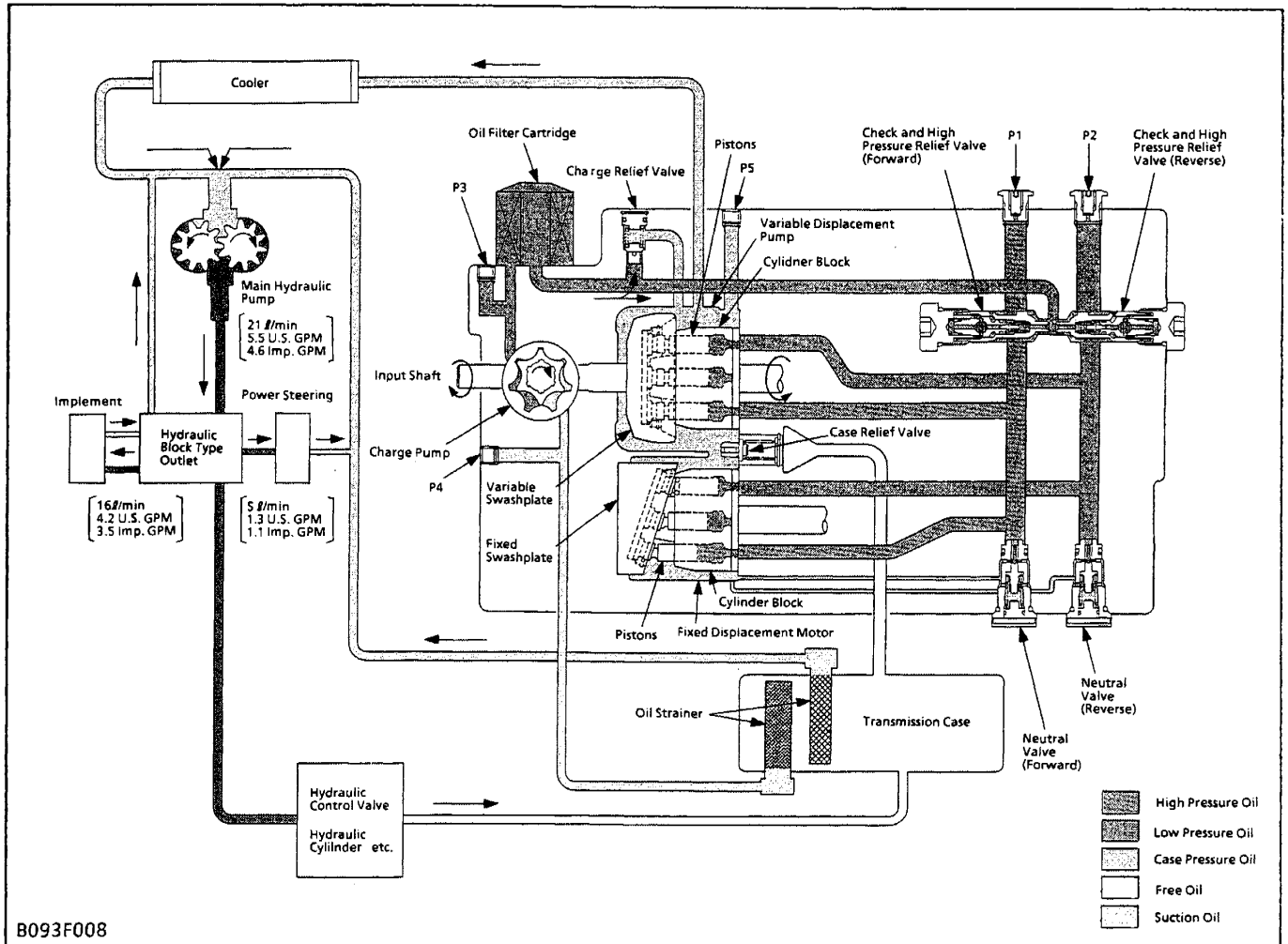

P1: Port for checking high pressure (forward)
 P2: Port for checking high pressure (reverse)
 P3: Port for checking case pressure

P4: Port for checking vacuum
 P5: Port for checking case pressure

The pump and motor are joined in a closed hydraulic loop and most of oil circulates within the main oil circuit. A little oil lubricates and oozes out from the clearance between the moving parts of the case. Then oil in the main oil circuit of the hydrostatic transmission needs to be supplied a want. So all of oil fed from the main hydraulic pump flows to the hydrostatic transmission for charging.

Only return oil from the hydraulic cylinder drops to the transmission case.

The charge oil aids smooth operation of piston pump and motor. The rest of the oil passes through the charge relief valve into the case. Then the oil passes to the main hydraulic pump through a cooler.

■ Charge Relief Valve

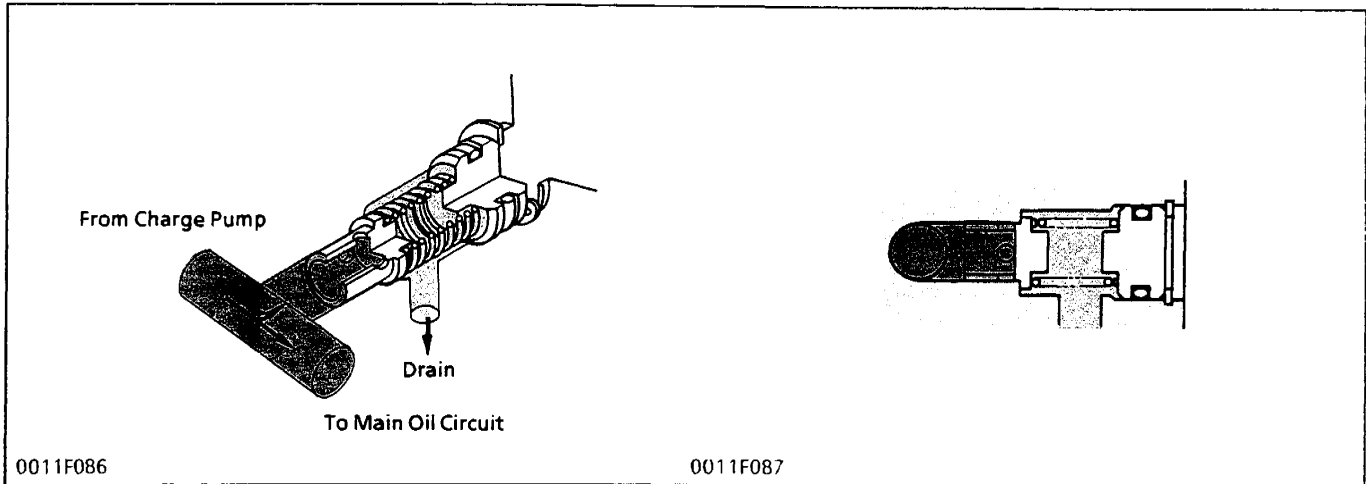

While pumped and filtered oil flows into the main oil circuit through the check valves, excessive oil passes to the case through the charge relief valve.

Oil temperature	Valve operating pressure
50°C (122°F)	392 to 588 kPa (4.0 to 6.0 kgf/cm ² , 57 to 85 psi) more than case pressure

■ Neutral Valve

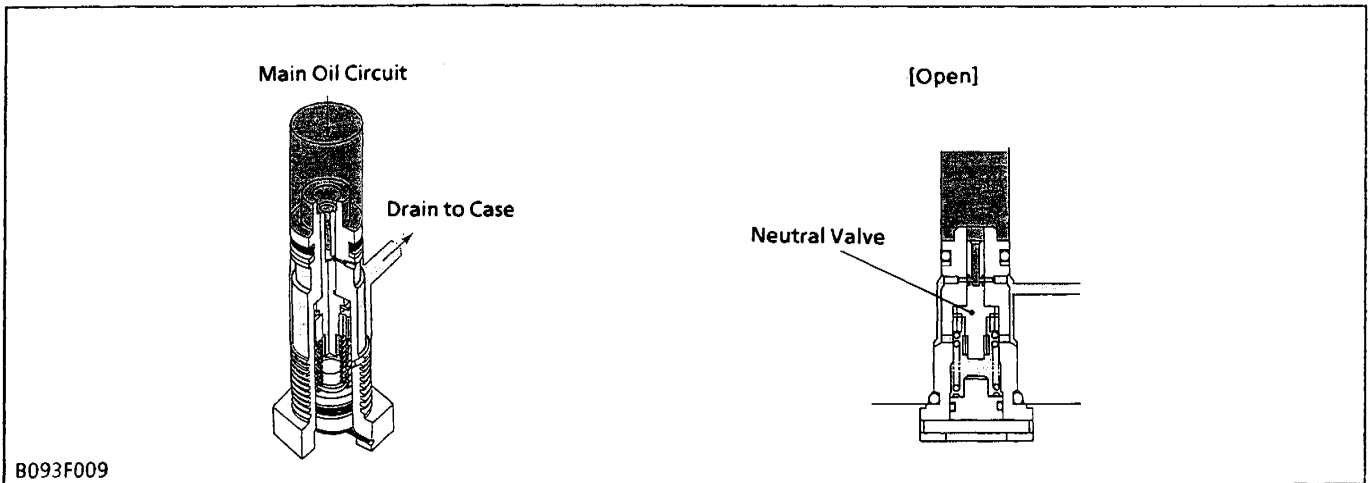

The neutral valves in the main oil circuit lines are open and pass the oil to the case when in neutral, and the oil pressure in their lines becomes low. And when the oil pressure in the high pressure line increases to a specified pressure, the neutral valve closes.

Oil temperature	Valve operating pressure	
50°C (122°F)	Close	2.45 to 3.73 MPa (25 to 38 kgf/cm ² , 356 to 540 psi)
	Open	1.47 MPa (15 kgf/cm ² , 213 psi)

■ Check and High Pressure Relief Valve

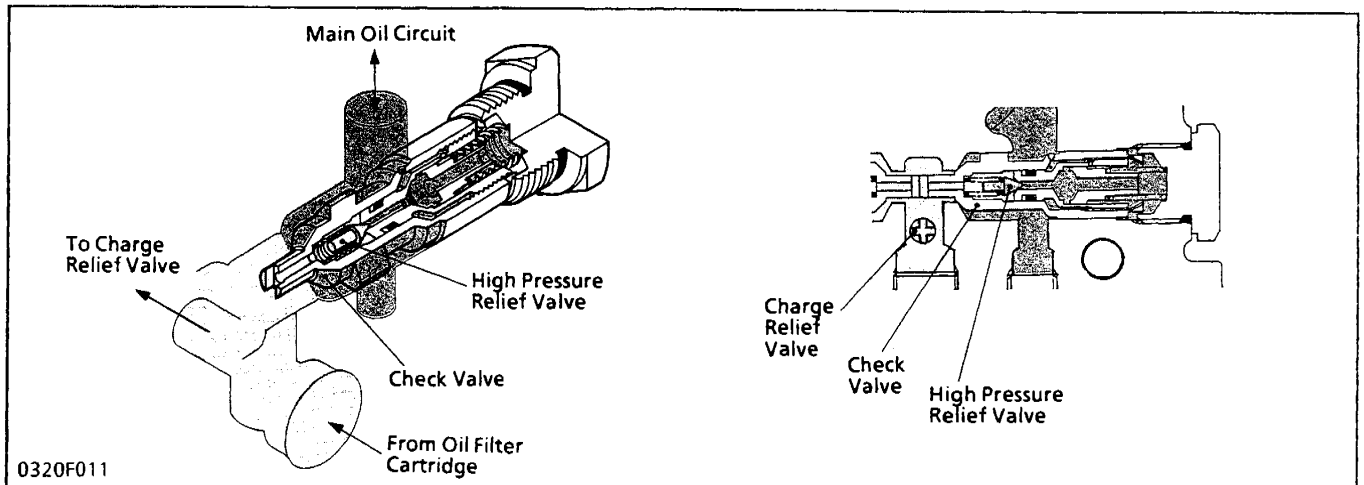

0320F011

The check and high pressure relief valves monitor the oil pressure in each line of the main oil circuit.

In neutral, both valves are open and charging oil enters into the main oil circuit through the valves.

At normal operation, the check valve in the high pressure side is closed and it pushes and opens the another one.

When excessively high pressure is built up in one line, the high pressure relief valve located in this line is open and the oil flows into another line.

Oil temperature	Relief valve operating pressure
50°C (122°F)	24.0 to 25.0 Mpa (245 to 255 kg/cm ² , 3485 to 3627 psi)

■ Case Relief Valve

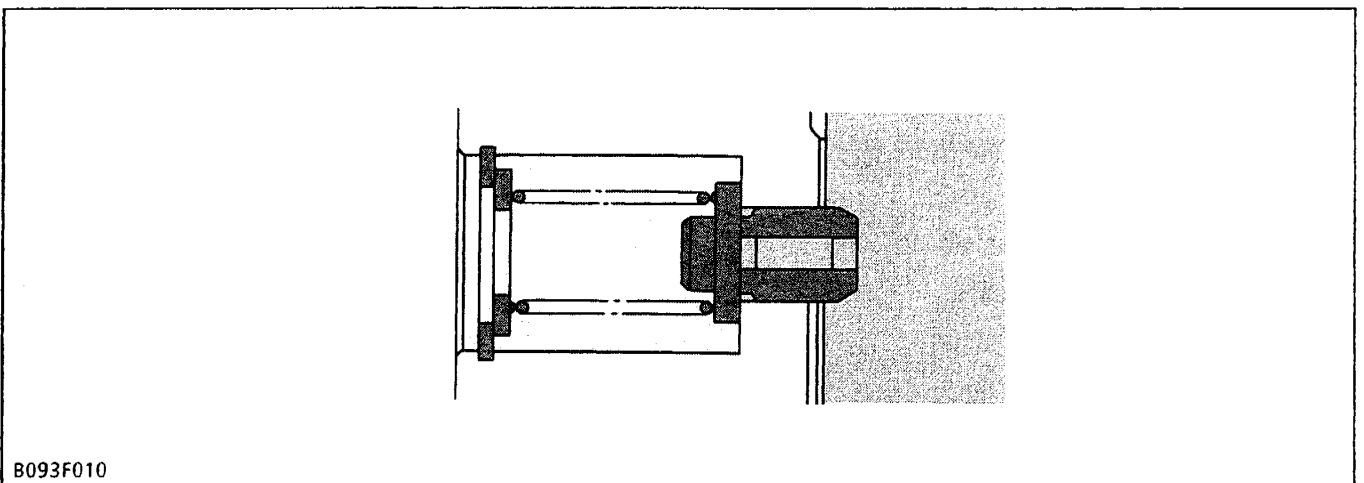

B093F010

The case relief valve monitors the oil pressure in the hydrostatic transmission case. When the oil pressure rises, it opens and flows the oil directly to the transmission case, so that the oil may not leak against the sealings.

Oil temperature	Valve operating pressure
50°C (122°F)	98 to 294 kpa (1 to 3 kgf/cm ² , 14 to 43 psi)

5. Operation

■ Neutral

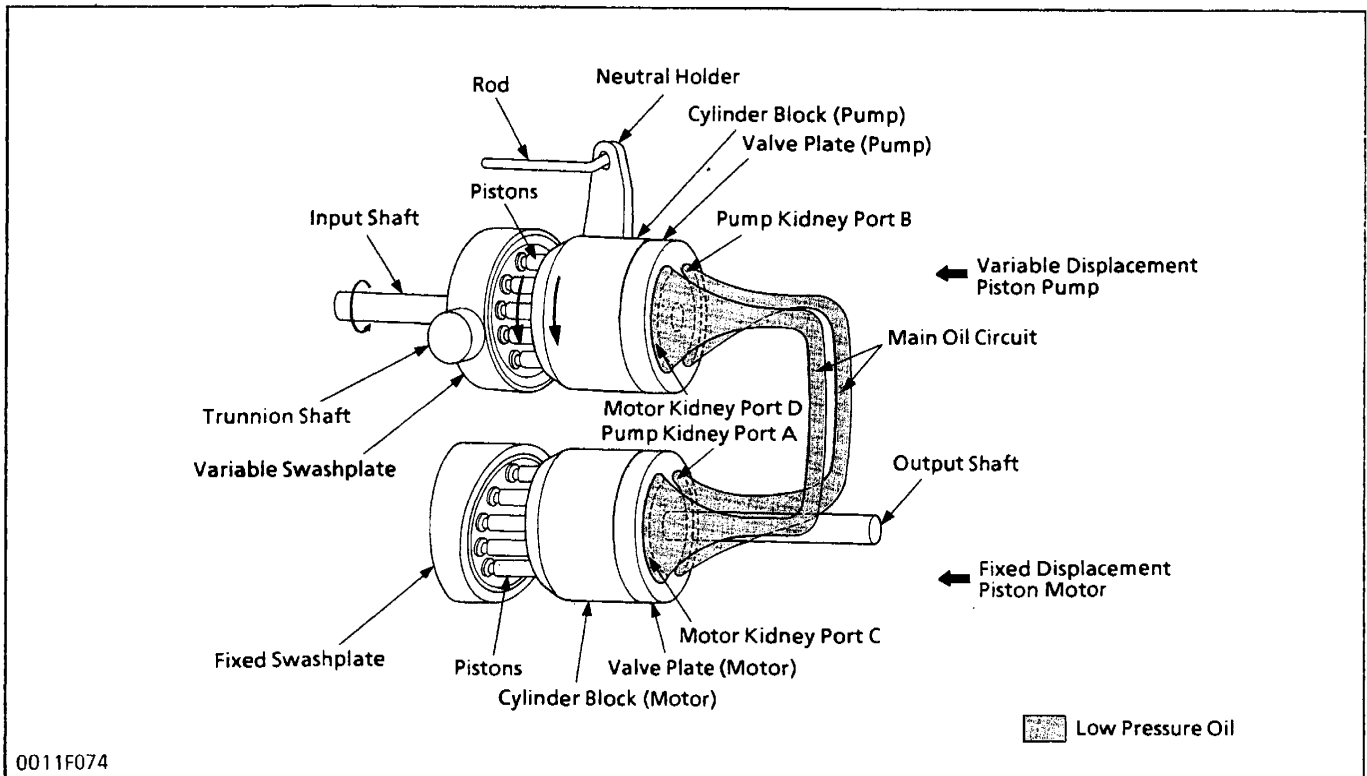

When the speed control pedal is in neutral, the variable swashplate is at right angles to the pump pistons and they only rotate with cylinder block without reciprocating. Since the oil is not being

pumped to the motor, the cylinder block in the motor is stationary and the output shaft does not move.

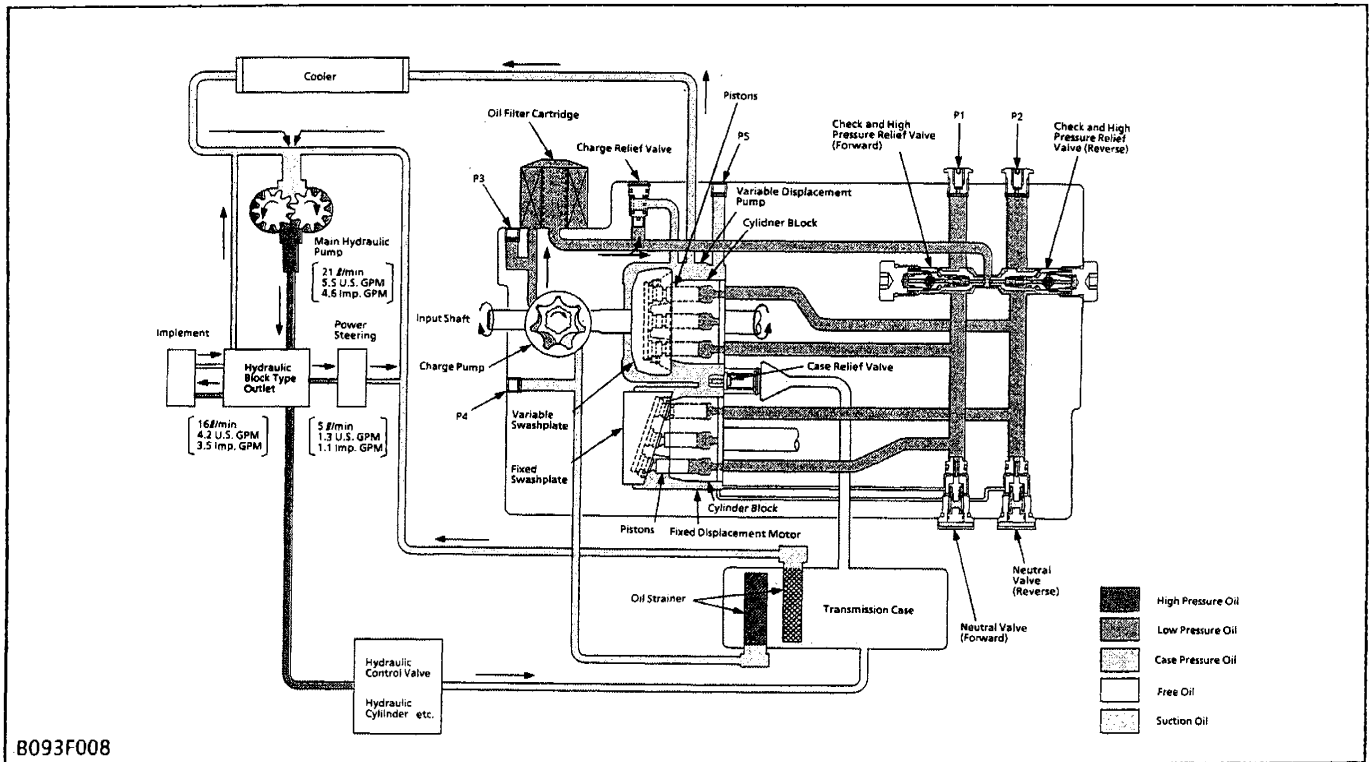

■ Forward

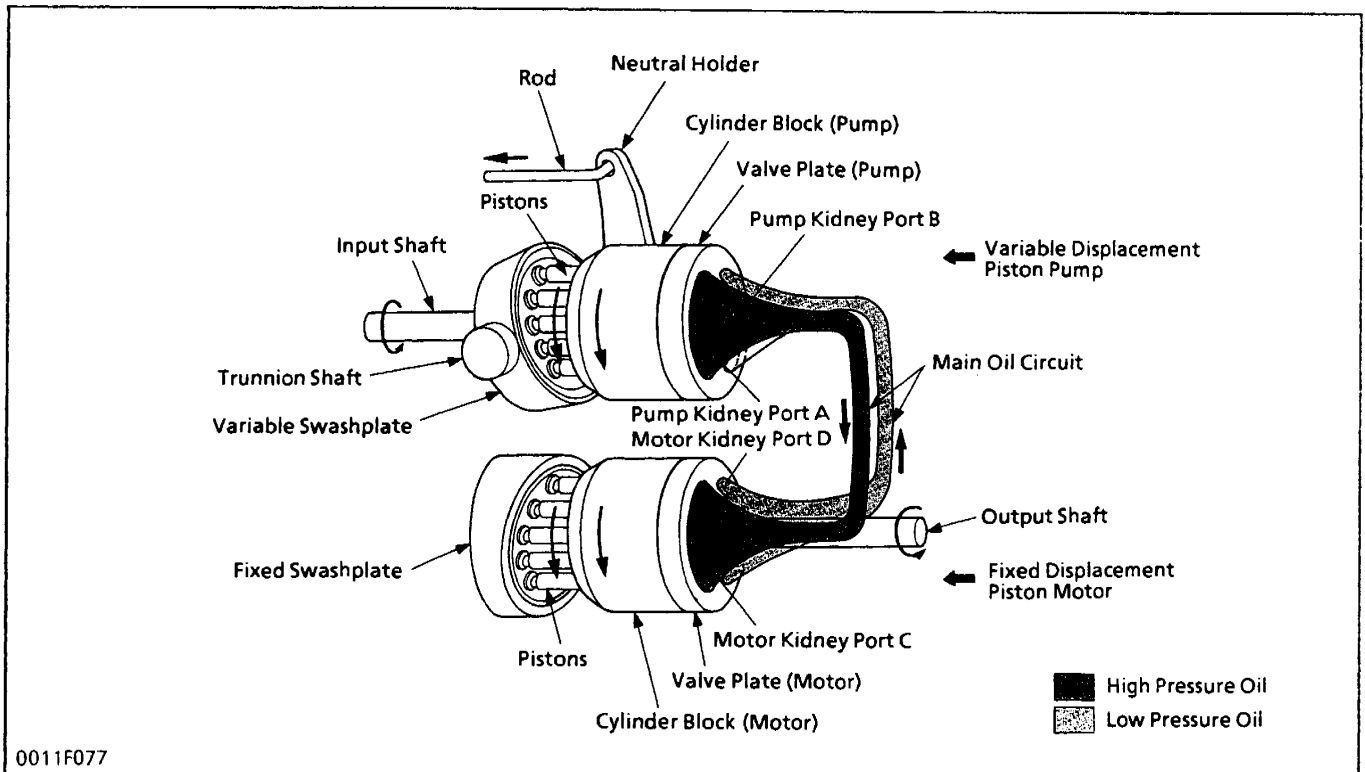

When the speed control pedal is stepped on and in forward, the variable swashplate is tilted as shown in figure above.

As the pump cylinder block rotates with the input shaft, oil is forced out of pump kidney port A at high pressure. As pressure oil enters motor kidney port C, the pistons, which align with port C, are pushed against the swashplate and slide down the inclined surface.

Then the output shaft rotates with the motor cylinder block. This drives the machine forward and the angle of pump swashplate determines the output shaft speed.

As the motor cylinder block continues to rotate, oil is forced out of motor kidney port D at low pressure and returns to the pump.

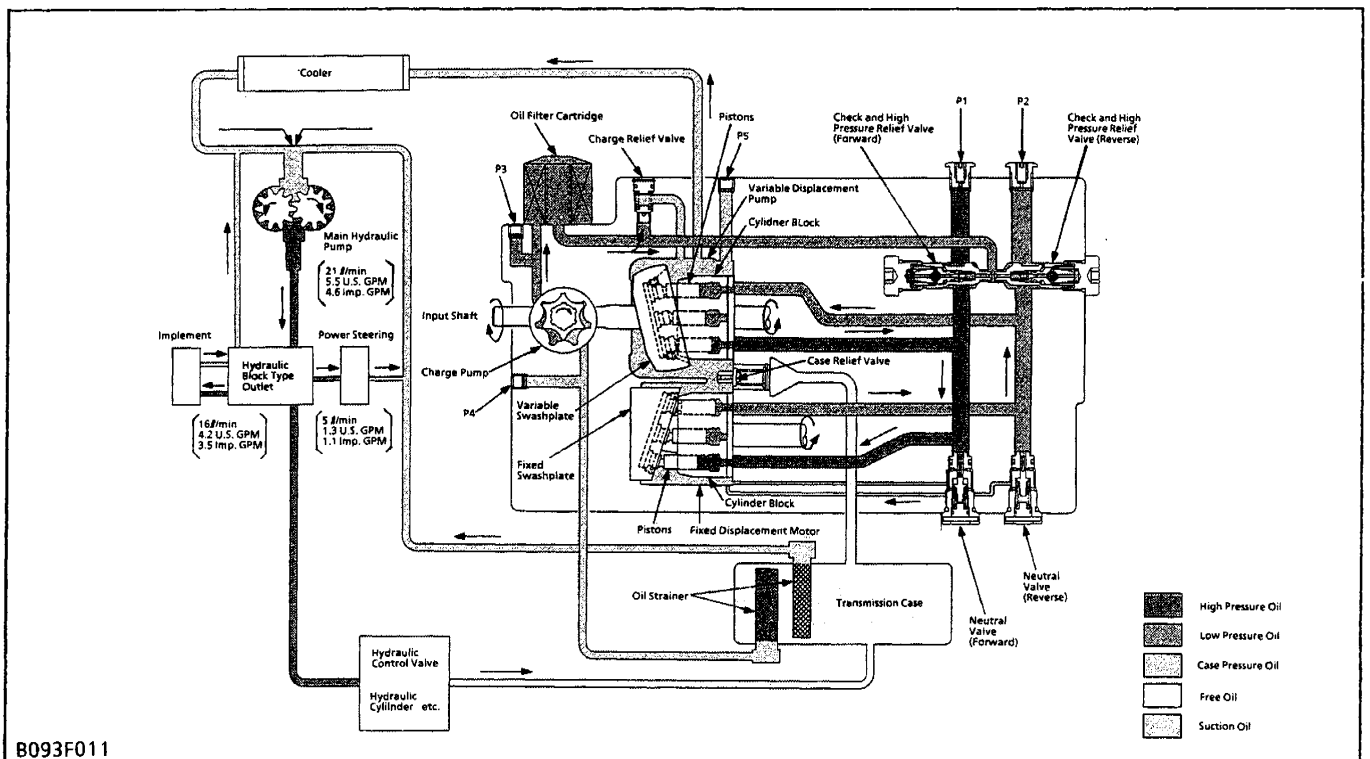

Reverse

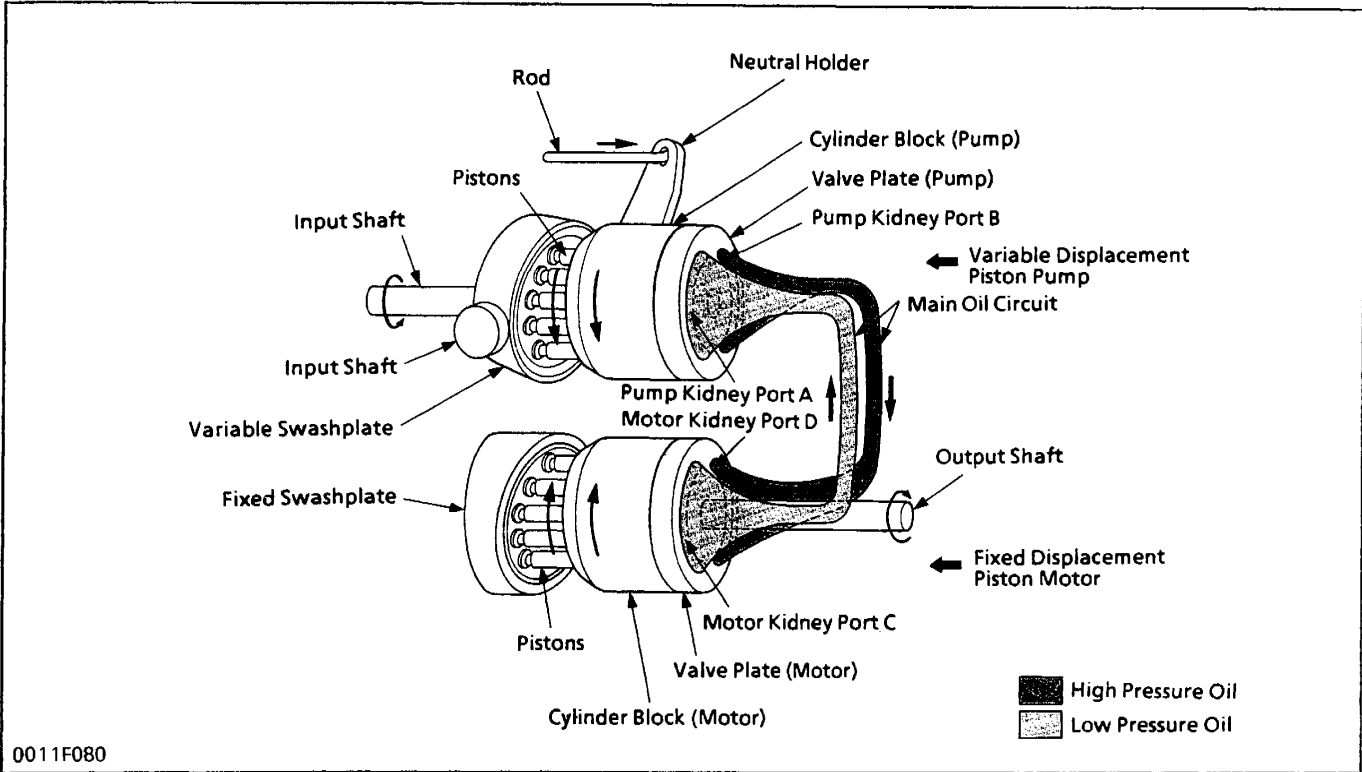

0011F080

When the speed control pedal is stepped on and in reverse, the variable swashplate is tilted as shown in figure above.

As the pump cylinder block rotates with the input shaft, oil is forced out of pump kidney port B at high pressure. As pressure oil enters motor kidney port D, the pistons, which align with port D, are pushed against the swashplate and slide down the inclined surface.

Then the output shaft rotates with the motor cylinder block. This drives the machine rearward and the angle of pump swashplate determines the output shaft speed.

As the motor cylinder block continues to rotate, oil is forced out of motor kidney port C at low pressure and returns to the pump.

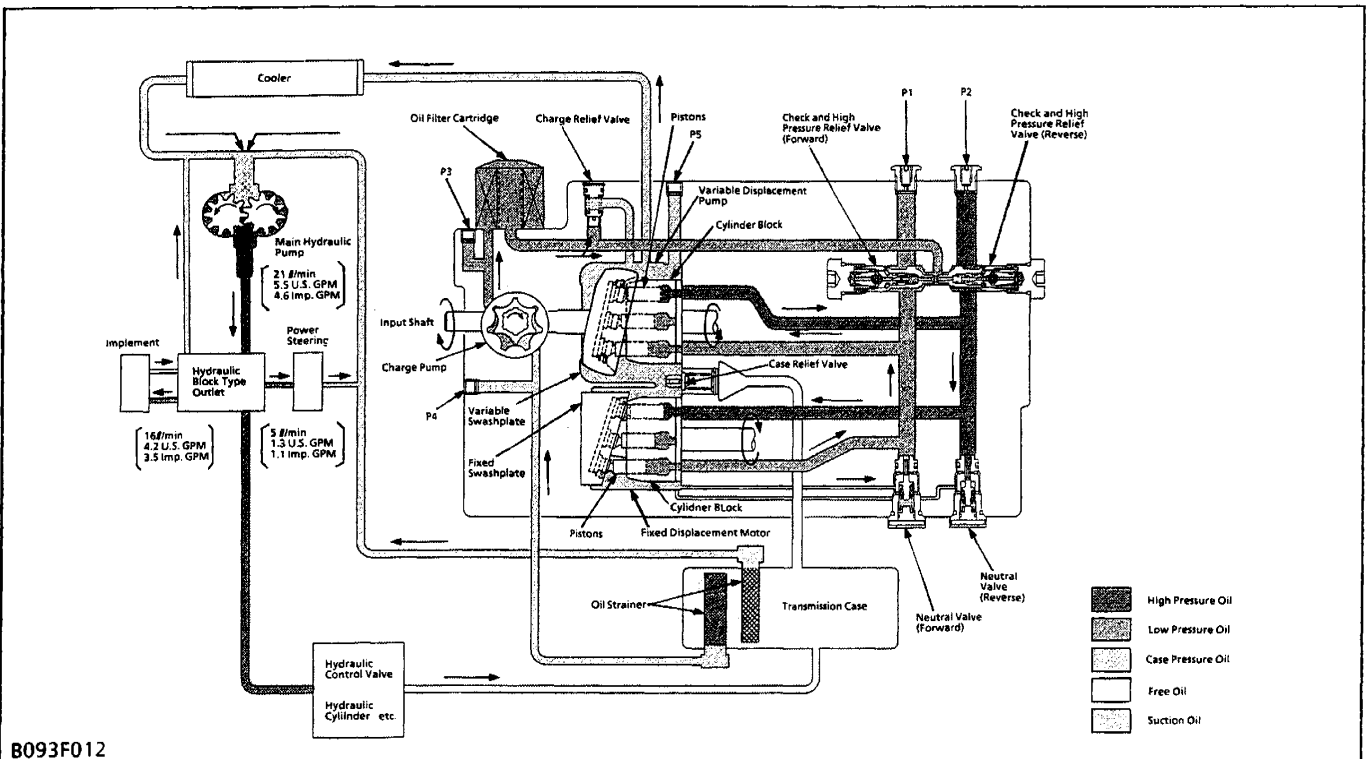

B093F012

6. Control Linkage

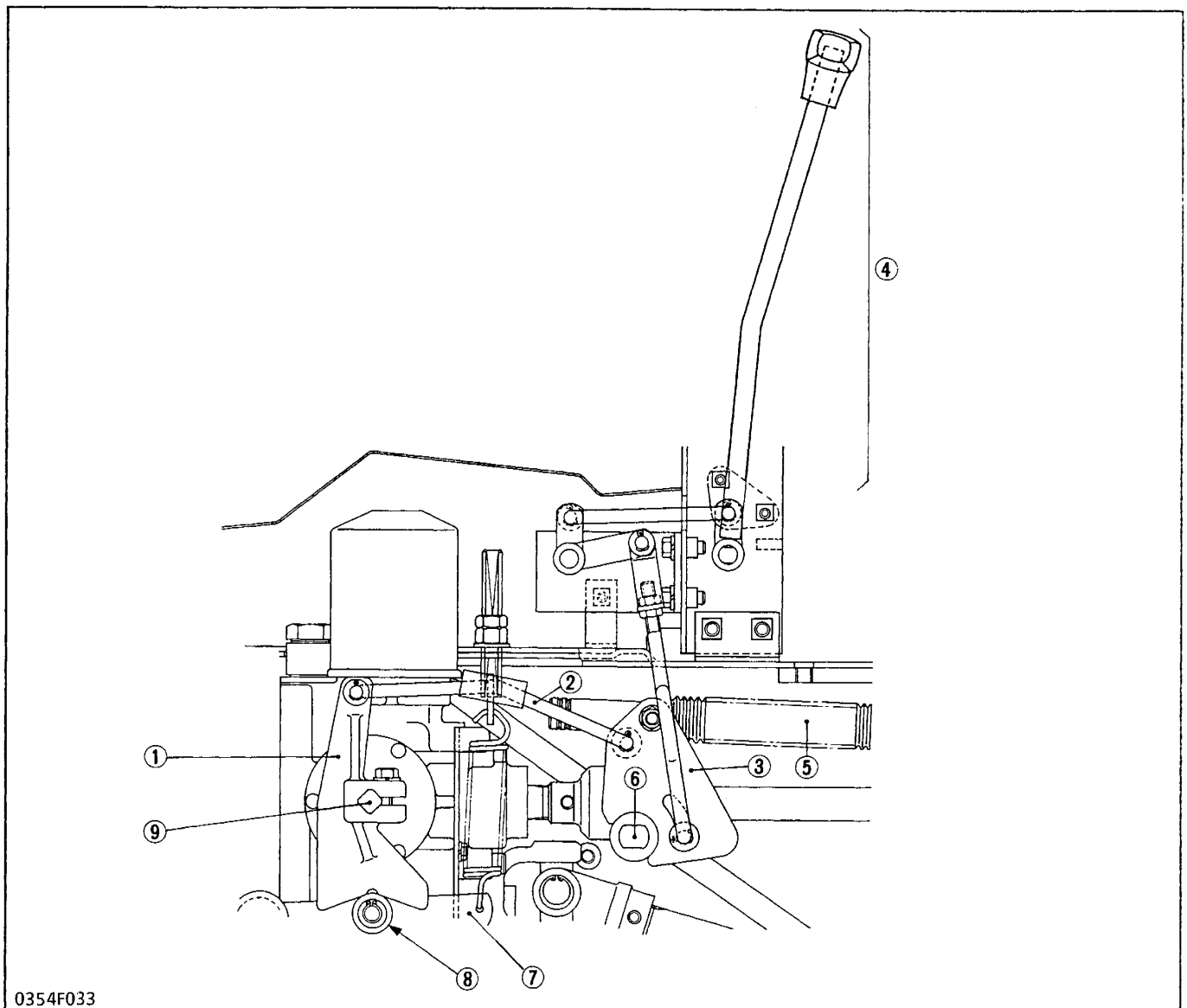

0354F033

- | | | | |
|-----------------------|----------------------|-------------------------------|--------------------|
| (1) Neutral Holder | (4) Speed Set Device | (6) Speed Control Pedal Shaft | (8) Roller |
| (2) Speed Control Rod | (5) Damper | (7) Neutral Holder Arm | (9) Trunnion Shaft |
| (3) Rod Guide | | | |

The speed control pedal and the trunnion shaft (9) of variable swashplate are linked with the rod guide (3), the speed control rod (2) and the neutral holder (1). As the front footrest of the pedal is depressed, the swashplate rotates and forward travelling speed increases. Depressing the rear footrest increases reverse speed.

The roller (8) on the neutral holder arm (7) hanged with spring seats the detent of the neutral holder (1) so that the neutral holder returns to neutral.

Then, the swashplate is returned to neutral with the neutral holder, when the pedal is released. The damper (5) connected to the rod guide (3) restricts the movement of the linkage to prevent abrupt operation or reversing.

The speed set device (4) linked to the rod guide (3) enables the linkage not to return to neutral and to keep a certain forward speed while the speed control pedal (6) is released.

3 TRANSMISSION

NOTE

- Tractor serial number B1550HST-E above 20001
B1550HST-D above 60001
B1750HST-E above 20001
B1750HST-D above 60001

SERVICING SPECIFICATIONS

Item		Factory Specification	Allowable Limit
Speed Set Lever	Force (See page BS.3-3)	29.4 to 34.3 N 3.0 to 3.5 kgf 6.6 to 7.7 lbs.	—
Check and High Pressure Relief Valve	Setting Pressure [Relief Valve]	24.0 to 25.0 Mpa 245 to 255 kgf/cm ² 3485 to 3627 psi (Oil temperature at 50°C, 122°F)	—
	Spring Length (short) [Relief Valve]	(free) 12.4 mm 0.488 in. load 41.84 N, 4.27 kgf, 9.41 lbs 10.5 mm 0.413 in.	—
	Spring Length (long) [Check Valve]	(free) 18.2 mm 0.717 in. load 3.43 N, 0.35 kgf, 0.77 lbs 14.5 mm 0.571 in.	—
Case Relief Valve	Setting Pressure	98 to 294 kPa 1 to 3 kgf/cm ² 14 to 43 psi (Oil temperature at 50°C, 122°F)	—
Case Relief Valve Spring	Spring Length	(free) 23.0 mm 0.906 in. load 29.4 N, 3.0 kgf, 6.6 lbs 15.0 mm 0.591 in.	—
Charge Relief Valve	Setting Pressure	392 to 558 kPa 4.0 to 6.0 kgf/cm ² 57 to 85 psi more than case pressure (Oil temperature at 50°C, 122°F)	—
Piston to Bore	Clearance	0.02 mm 0.0008 in.	0.04 mm 0.0016 in.
Slipper	Thickness	3.00 mm 0.118 in.	2.90 mm 0.114 in.

SERVICING SPECIFICATIONS (Continued)

Item		Factory Specification	Allowable Limit
Vacuum	Setting Pressure	120 mmHg (Oil temperature at 25°C, 77°F)	—
		60 mmHg (Oil temperature at 50°C, 122°F)	—
		35 mmHg (Oil temperature at 80°C, 176°F)	220 mmHg (Oil temperature at 80°C, 176°F)
Neutral Valve	Setting Pressure	Close 2.45 to 3.73 Mpa [25 to 38 kgf/cm ² , 356 to 540 psi] Open 1.47 Mpa [15 kgf/cm ² , 213 psi] (Oil temperature at 50°C, 122°F)	—
	Spring Length	(free) 18.4 mm 0.7244 in. load 43.2 N, 4.4 kgf, 9.7 lbs 13.9 mm 0.5472 in.	— —

TIGHTENING TORQUES

Item	N·m	kgf·m	ft-lbs
Neutral Adjuster	18.6 to 32.3	1.9 to 3.3	13.7 to 23.9
Charge Pump	23.5 to 27.5	2.4 to 2.8	17.4 to 20.3
Motor Swashplate	15.7 to 20.6	1.6 to 2.1	12 to 15
Port-block	48.1 to 55.9	4.9 to 5.7	35.4 to 41.2
High Relief Valve Seat	23.5 to 29.4	2.4 to 3.0	17.4 to 21.7
High Relief Valve Cap Nut	58.8 to 68.6	6.0 to 7.0	43.4 to 50.6
Neutral Valve	53.9 to 63.7	5.5 to 6.5	39.8 to 47.0
Plug (Drain)	49.0 to 58.8	5.0 to 6.0	36.2 to 43.4
Plug (P1, P2)	19.6 to 24.5	2.0 to 2.5	14.5 to 18.1
Plug (P1, P2) PT 3/8	29.4 to 39.2	3.0 to 4.0	21.7 to 28.9
Plug Seat (P1, P2)	49.0 to 58.8	5.0 to 6.0	36.2 to 43.4
Plug (P3, P4, P5)	8.8 to 10.8	0.9 to 1.1	6.5 to 8.0
HST Case to Transmission Case	48.1 to 55.9	4.9 to 5.7	35.4 to 41.2
Mid PTO Case Bearing Holder	13.7 to 19.6	1.4 to 2.0	10.1 to 14.5
Case Cover to Case			
Mid PTO Case to Transmission Case	48.1 to 55.9	4.9 to 5.7	35.4 to 41.2
Rear Cover Mounting Screw	39.2 to 64.7	4.0 to 6.6	28.9 to 47.7
PTO Shaft Screw	18.6 to 32.4	1.9 to 3.3	13.7 to 23.9

■ NOTE

- Tractor serial number B1550HST-E above 20001
 B1550HST-D above 60001
 B1750HST-E above 20001
 B1750HST-D above 60001

CHECKING, DISASSEMBLING AND SERVICING

[1] SPEED SET DEVICE (B1550HST-B1750HST)

DISASSEMBLING AND ASSEMBLING

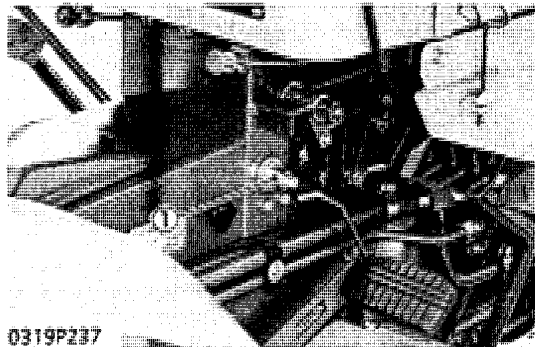

Speed Set Lever

1. Measure the force to move the speed set lever (A) forward at its top (grip).
2. If the force is not within the factory specification, turn the nut (1) to adjust.

Force to move the lever	Factory spec.	29.4 to 34.3 N 3.0 to 3.5 kgf 6.6 to 7.7 lbs
-------------------------	---------------	--

(When reassembling)

- After installing the spring (3), align the head of nut (2) with the punched mark (4).

- (1) Nut
- (2) Nut
- (3) Spring
- (4) Punched Mark

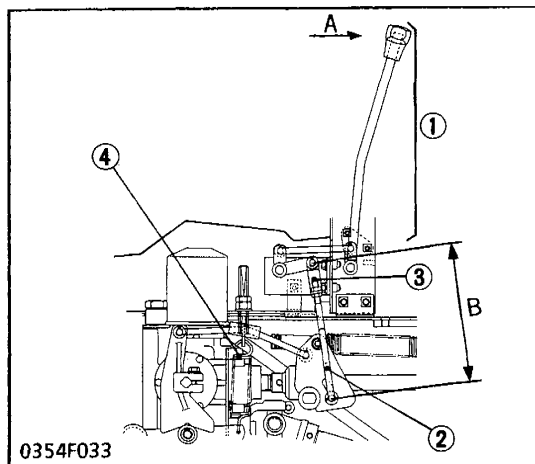
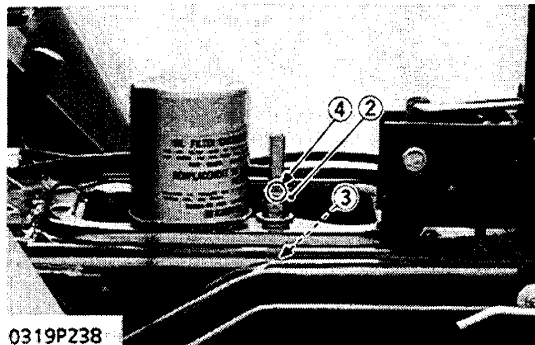

Setting Length of Lower Rod

1. Measure the length "B".
2. If the measurement is not within the factory specifications, adjust with the yoke (3) of the lower rod (2).

Setting length of lower rod	Factory spec	178 mm 7.01 in.
-----------------------------	--------------	--------------------

- (1) Speed Set Lever
- (2) Lower Rod
- (3) Yoke
- (4) Spring

[2] HYDROSTATIC TRANSMISSION (B1550HST-B1750HST)

CHECKING AND ADJUSTING

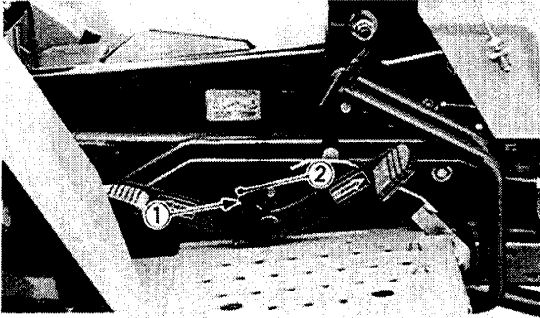

0319P239

Reverse Speed

1. Lift the rear of the tractor so that the rear wheels are off the ground.
2. Set the engine speed at 2600 rpm and depress the differential lock pedal.
3. If the rear wheels do not turn within the factory specifications, loosen the lock nut (1) and adjust the bolt (2)

Rear wheel rpm	Factory spec.	127 to 137 rpm (Engine at 2600 rpm)
----------------	---------------	--

(1) Lock Nut

(2) Bolt

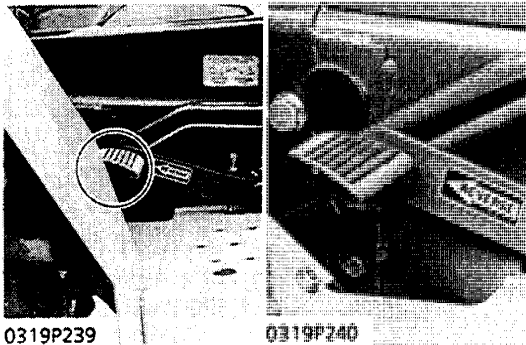

0319P239

0319P240

Neutral

1. Lift the rear of the tractor so that the rear wheels are off the ground and run the engine at low idling and drive only rear wheels.
2. Depress the one end of speed control pedal and release, and do the same at the other end.
3. If the rear wheels do not stop turning, adjust as following procedure.

NOTE

- Loosen the screw and be sure to place the neutral adjuster with its longer groove upward.

Adjusting Neutral

1. Rotate the neutral adjuster counterclockwise so that the rear wheels turn forward.
2. Then rotate it clockwise until wheels stop completely.
3. Put a mark on the clutch housing aligning the groove on neutral adjuster.
4. Rotate the neutral adjuster clockwise so that the rear wheels turn reverse.
5. Then rotate it counterclockwise until wheels stop completely.
6. Put a mark on the clutch housing aligning the groove on neutral adjuster.
7. Hold the neutral adjuster so that its groove is at the middle of the marks and tighten the screw.

NOTE

- When the wheels tend to turn forward, rotate the neutral adjuster clockwise.
- When the wheels tend to turn reverse, rotate the neutral adjuster counterclockwise.

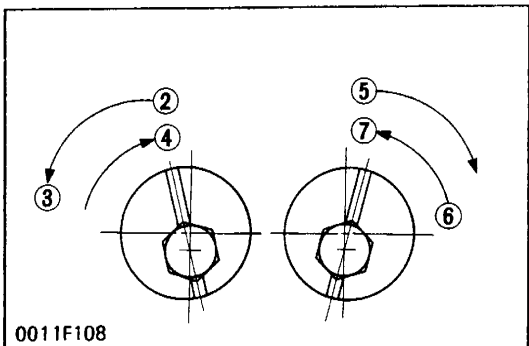

0011F108

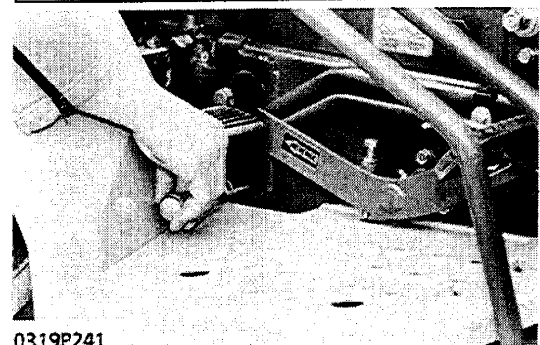

0319P241

Tightening torque	Neutral adjuster to case	19 to 32 N·m 1.9 to 3.3 kgf·m 13 to 24 ft·lbs
-------------------	--------------------------	---

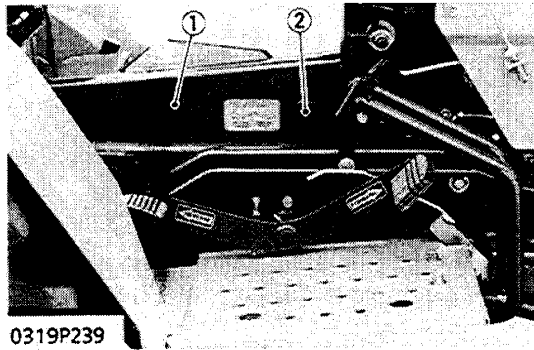

0319P239

Oil Pressure in Hydrostatic Transmission

1. Clean and clear the work area, and fully engage the parking brake.
2. Remove the knob screws (2) and sub cover (1).
3. Measure the following oil pressures using Hydrostatic Transmission Testing Kit (Code No. 07916-52040) as instructed.

(1) Sub Cover

(2) Knob Screw

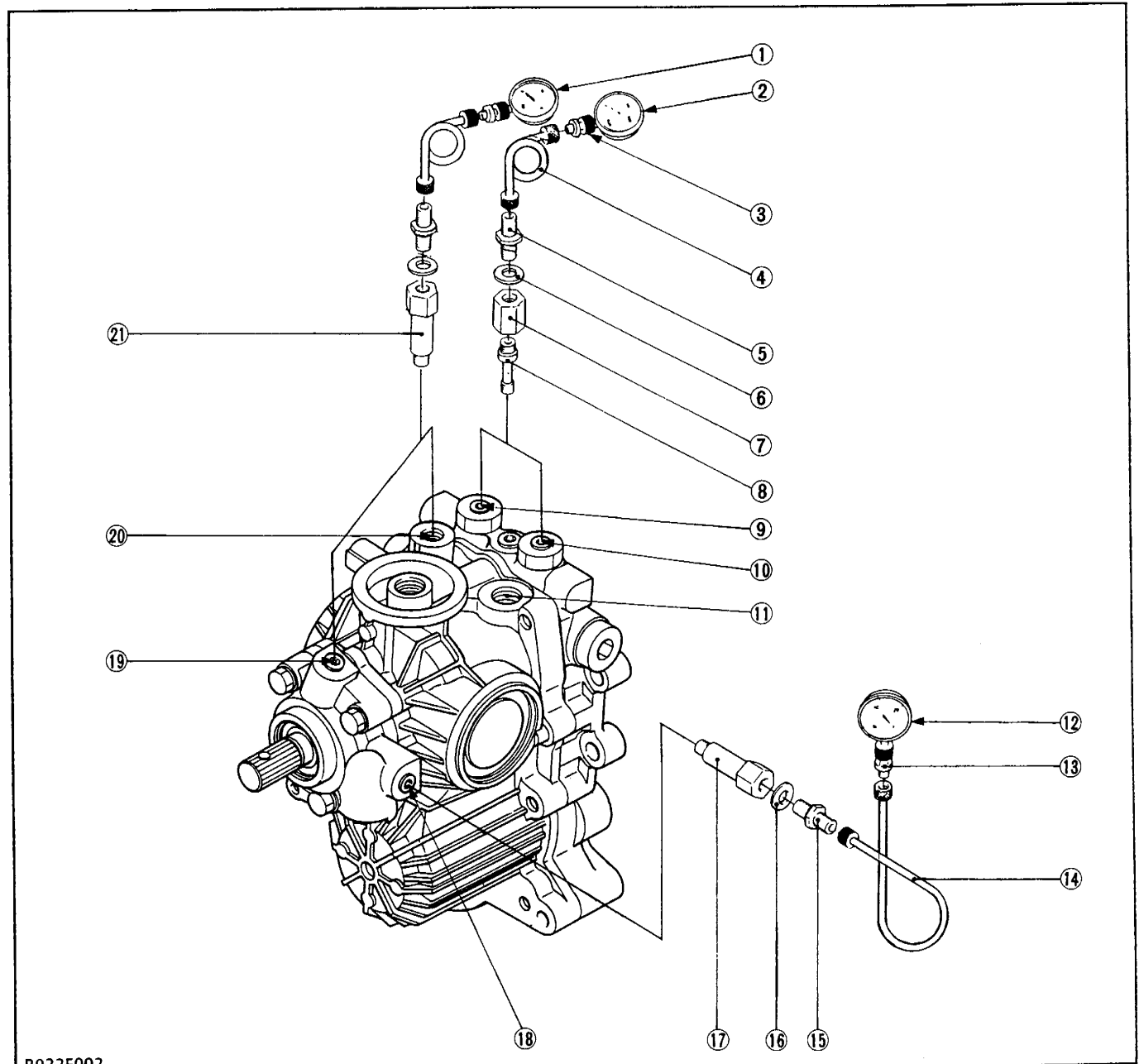

B022F002

- | | | |
|--|--|-----------------------------------|
| (1) Pressure Gauge (07916-51301) | (7) Connector 1 (07916-60811) | (14) Cable (07916-50331) |
| (2) Pressure Gauge (High Pressure)(07916-50322) | (8) Connector 2 (07916-60821) | (15) Thread Joint (07916-50341) |
| (3) Threaded Joint in Relief Valve Pressure Tester (07916-50401) | (9) High Pressure (Reverse), P2 port | (16) Gasket (04714-00200) |
| (4) Cable (07916-51331) | (10) High Pressure (Forward), P1 port | (17) Long Connector (07916-60831) |
| (5) Thread Joint (07916-50341) | (11) T1 port | (18) Vacuum, P4 port |
| (6) Gasket(04714-00200) | (12) Vacuum Gauge (07916-51331) | (19) Charge Pressure, P3 port |
| | (13) Treaded joint in Relief Valve Pressure Tester (07916-50401) | (20) Case Pressure, P5 port |
| | | (21) Long Connector (07916-60831) |

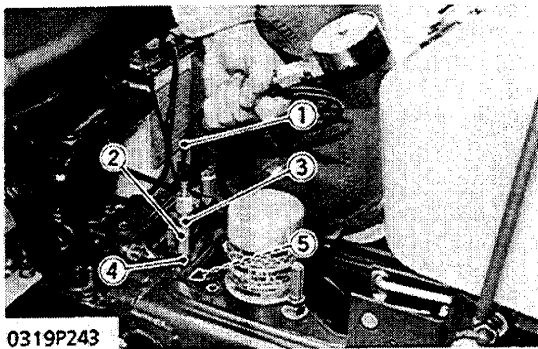
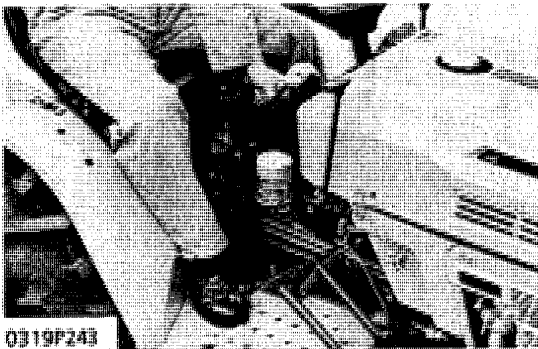
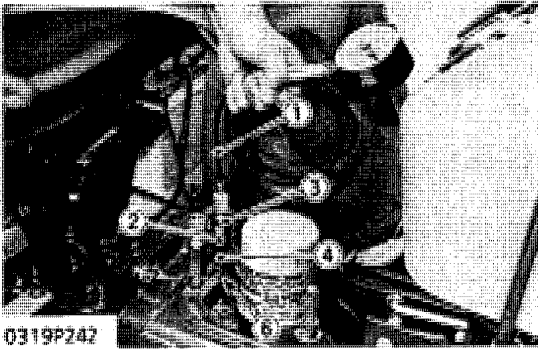

High Relief Pressure

1. Remove the M 10 hex socket head plug from P1 (6) or P2 (5) port (P1 is for forward and P2 is for reverse).
2. Install connector 2 (4) to P1 (forward) or P2 (reverse) port.
3. Assemble connector 1 (2) and threaded joint (3) with the gasket between them.
4. Install the assembled connector 1 (2) and threaded joint (3) to connector 2 (4).
5. Install the cable (1), threaded joint in relief valve set pressure tester and high pressure gauge to threaded joint (3) in order.
6. Run the engine at 2600 rpm.
7. Place the high-low shift lever in high.
8. Depress the speed control pedal approx. 10 mm (0.39 in.) which rotates the trunnion shaft 0.087 rad (5.0°).

High relief pressure (Oil temperature at 50°C, 122°F)	Factory spec.	24.0 to 25.0 MPa 245 to 255 kgf/cm ² 3485 to 3627 psi
---	---------------	--

IMPORTANT

- Measure quickly so that the relief valve may not be in operation more than 10 seconds.

NOTE

- High pressure gauge is 30 MPa (300 kgf/cm², 4260 psi) full scale.

(When reassembling)

- Install the M 10 plug to the port with the gasket laying on its seat.

Tightening torque	Plug (P1, P2 port)	19.6 to 24.5 N·m 2.0 to 2.5 kgf·m 14 to 18 ft·lbs
	Plug seat (P1, P2 port)	49.0 to 58.8 N·m 5.0 to 6.0 kgf·m 36.2 to 43.4 ft·lbs

- | | |
|--------------------|-----------------|
| (1) Cable | (4) Connector 2 |
| (2) Connector 1 | (5) P2 Port |
| (3) Threaded Joint | (6) P1 Port |

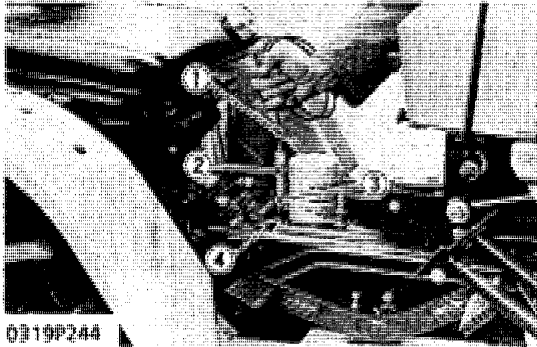

0319P244

- (1) Cable
- (2) Threaded Joint
- (3) Long Connector
- (4) P5 Port

Case Relief Pressure

1. Remove the PT 1/4 plug from P5 port (4), with care not to allow any particle of sealing tape enter into the port.
2. Install the long connector (3) to P5 port with sealing tape on its thread.
3. Install the threaded joint (2) to long connector with the gasket between them.
4. Install the cable (1), threaded joint in relief valve set pressure tester and low pressure gauge to threaded joint in order.
5. Run the engine at 2600 rpm.
6. Place the high-low shift lever in neutral
7. Release the speed control pedal to set in neutral.
8. After measuring the case pressure, remove the eye joint from T1 port and plug the port with PF 3/8 screw to measure the case relief pressure.

Case relief pressure (Oil temperature at 50°C, 122°F)	Factory spec.	98 to 294 kPa 1 to 3 kgf/cm ² 14 to 43 psi
---	---------------	---

NOTE

- Low pressure gauge is 2 MPa (20 kgf/cm², 284 psi) full scale.

(When reassembling)

- Install the PT 1/4 plug to the P3 port with the sealing tape on its thread.

Tightening torque	Plug (P5 port)	8.8 to 10.8 N·m 0.9 to 1.1 kgf·m 6.5 to 7.9 ft·lbs
-------------------	----------------	--

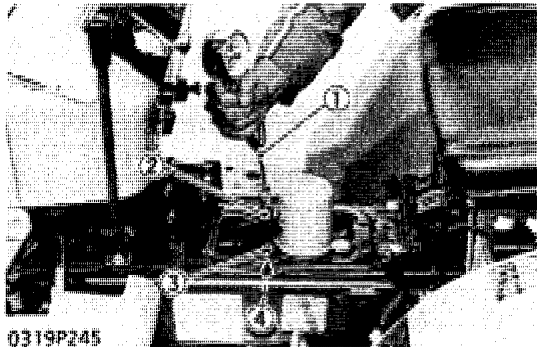

0319P245

- (1) Cable
- (2) Threaded Joint
- (3) Long Connector
- (4) P3 Port

Charge Pressure

1. Remove the PT 1/4 plug from P3 port (4), with care not to allow any particle of sealing tape enter into the port.
2. Install the long connector (3) to P3 port with sealing tape on its thread.
3. Install the threaded joint (2) to long connector with the gasket between them.
4. Install the cable (1), and threaded joint in order.
5. Run the engine at 2600 rpm.
6. Place the high-low shift lever in neutral.
7. Release the speed control pedal to set in neutral.

Charge pressure (Oil temperature at 50°C, 122°F)	Factory spec.	392 to 558 kPa 4.0 to 6.0 kgf/cm ² 57 to 85 psi
--	---------------	--

NOTE

- Low pressure gauge is 2 MPa (20 kgf/cm², 284 psi) full scale.

(When reassembling)

- Install the PT 1/4 plug to the P3 port with the sealing tape on its thread.

Tightening torque	Plug (P3 port)	8.8 to 10.8 N·m 0.9 to 1.1 kgf·m 6.5 to 7.9 ft·lbs
-------------------	----------------	--

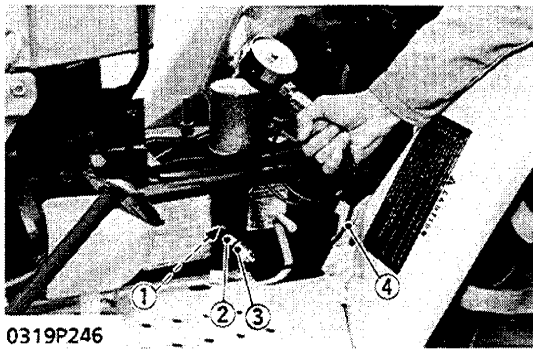

0319P246

- (1) P4 Port
- (2) Long Connector
- (3) Threaded Joint
- (4) Cable

Vacuum

1. Remove the PT 1/4 plug from P4 port (1), with care not to allow any particle of sealing tape enter into the port.
2. Install the long connector (2) to P4 port with sealing tape on its thread.
3. Install the threaded joint (3) to long connector with the gasket between them.
4. Install the cable (4), threaded joint in relief valve set pressure tester and vacuum gauge to threaded joint (3) in order.
5. Run the engine at 2600 rpm.
6. Place the high-low shift lever in neutral.
7. Release the speed control pedal to set in neutral.

Vacuum (Oil temperature)	Factory spec.	120 mm Hg (at 25°C, 77°F) 60 mm Hg (at 50°C, 122°F) 35 mm Hg (at 80°C, 176°F)
	Allowable limit	220 mm Hg (at 80°C, 176°F)

NOTE

- Vacuum gauge is 760 mm Hg (30 in. Hg) full scale.

(When reassembling)

- Install the PT 1/4 plug to the P4 port with the sealing tape on its thread.

Tightening torque	Plug (P3 port)	8.8 to 10.8 N·m 0.9 to 1.1 kgf·m 6.5 to 7.9 ft·lbs
-------------------	----------------	--

DISASSEMBLING AND ASSEMBLING

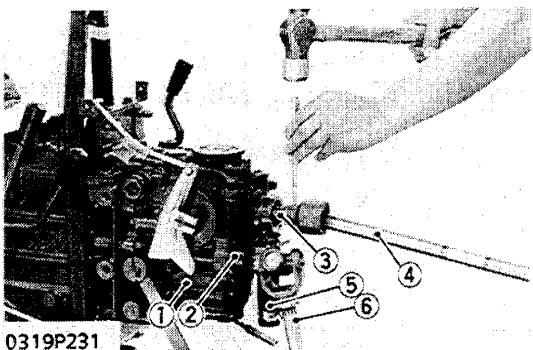

0319P231

- (1) HST
- (2) Front Wheel Drive Shaft
- (3) 1st Shaft
- (4) Propeller Shaft
- (5) Hose
- (6) Drive Shaft

Hydrostatic Transmission

1. Remove the propeller shaft (4) from the 1st shaft (3).
2. Remove the drive shaft (6) from the front wheel drive shaft (2). (4WD type only)
3. Loosen the hose clamp and remove the hose (5).
4. Remove the HST mounting screws, and remove the HST (1).

(When reassembling)

- After inserting the spring pin into the 1st shaft and drive shaft, lock the spring pin with a wire.
- Be sure to replace the gasket with a new one.

Tightening torque	HST mounting screw	48.1 to 55.9 N·m 4.9 to 5.7 kgf·m 35.4 to 41.2 ft·lbs
-------------------	--------------------	---

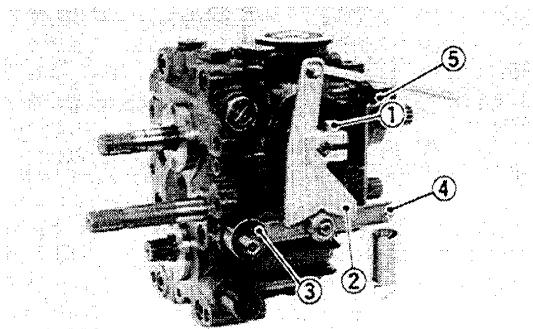

0319P256

- (1) Screw
- (2) Neutral Holder
- (3) Neutral Adjuster
- (4) Neutral Holder Arm
- (5) Spring Holder

Neutral Holder

1. Place parting marks on the neutral adjuster (3) and the neutral holder arm (4).
2. Remove the screws and spring holder (5).
3. Remove the screw and the neutral holder arm (4).
4. Remove the screw (1) and pull out the neutral holder (2).

(When reassembling)

- Aligning the parting marks, install the neutral adjuster and the neutral holder arm.

Tightening torque	Neutral holder arm mounting screw	18.6 to 32.4 N·m 1.9 to 3.3 kgf·m 14 to 24 ft·lbs
-------------------	-----------------------------------	---

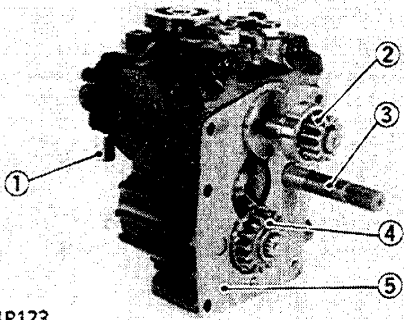

0011P123

- (1) Hose Joint
- (2) 14T Gear
- (3) Front Wheel Drive Shaft 1
- (4) 16T Gear
- (5) Gasket

Front Wheel Drive Shaft 1 and Gears

1. Pull out the front wheel drive shaft 1 (3) forward.
2. Remove the external snap ring and 14T gear (2).
3. Remove the external snap ring and 16T gear (4).
4. Remove the hose joint (1) and gasket (5).

(When reassembling)

- Install the snap ring with its rounded edge facing the gear or bearing so that its sharp edge in the groove keeps itself in place against the force.

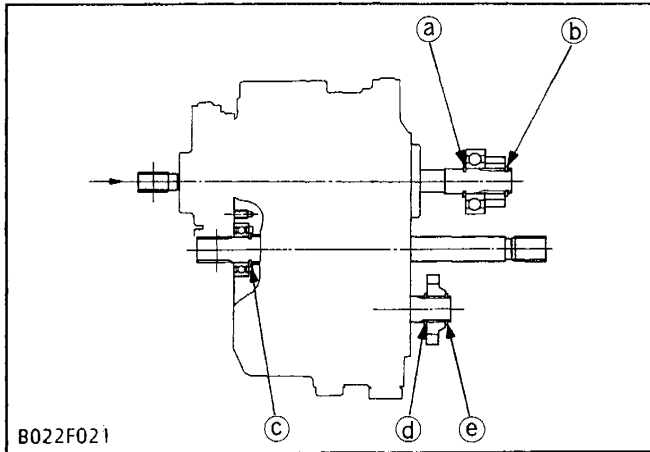

B022F021

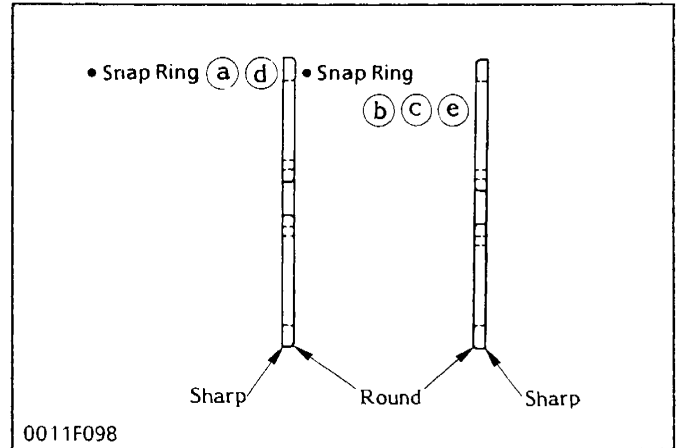

0011F098

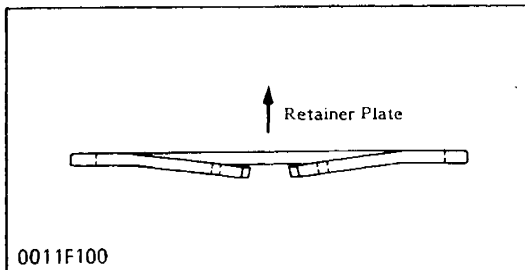

0011F100

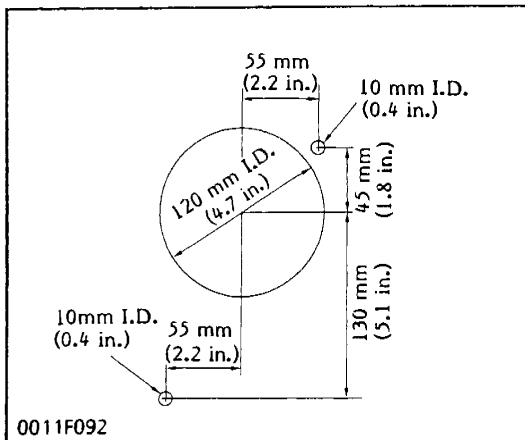

0011F092

Repair-stand for Assembling and Disassembling

1. To facilitate disassembling and assembling, make a repair stand as shown in the figure.

■ IMPORTANT

- Clean the repair-stand and the outside of the hydrostatic transmission case.
- Hydrostatic transmission is composed of many precision parts and they have highly finished or polished surface.
- Take extreme care to prevent damage or dirt during disassembling and assembling.
- Coat hands with hydrostatic transmission oil before handling the parts to minimize the possibility of rust.
- Clean the parts and coat them with hydrostatic transmission oil before assembling.

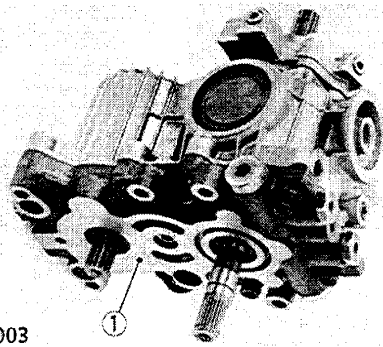

B093P003

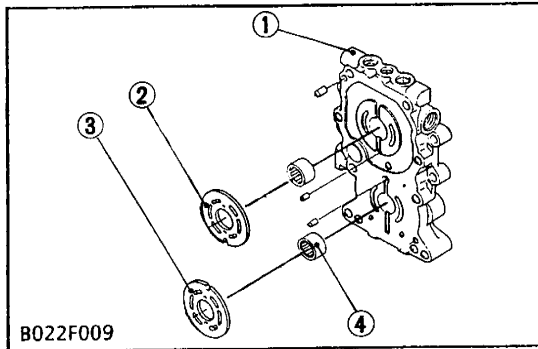

B022F009

Port Block

1. Remove the port block mounting screws, and tap the front of port block (1) with a soft hammer to separate from the case.

(When reassembling)

- Cover the splines of each shaft with thin tape to protect the sealing lip.
- Install port block with gasket, O-ring and valve plate in place.

■ IMPORTANT

- Valve plates (2), (3) may stick to the port block, but they are not fixed. Take care not to drop them.
- Valve plates are not interchangeable. Valve plate of the pump has two notches and the valve of the motor has no notches.

Tightening torque	Port block to case	48.1 to 55.9 N·m 4.9 to 5.7 kgf·m 35.4 to 41.2 ft·lbs
-------------------	--------------------	---

- | | |
|----------------------|-----------------------|
| (1) Port Block | (3) Motor Valve Plate |
| (2) Pump Valve Plate | (4) Needle Bearing |

Motor Cylinder Block

1. Hold the output shaft (1) and slightly tap the rear of case flange with a soft hammer to separate the motor cylinder block assembly.
2. Slide out the motor cylinder block (2) with pistons (3), retainer plate (4) and retainer holder (5).

(When reassembling)

- Aligning the hole on the swashplate to the dowel pin in the case, and install the output shaft assembly in the case.

- | | |
|--------------------------|---------------------|
| (1) Output Shaft | (4) Retainer Plate |
| (2) Motor Cylinder Block | (5) Retainer Holder |
| (3) Piston | |

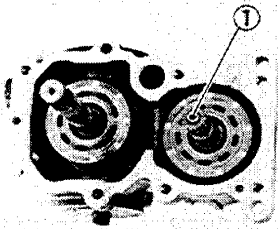

D011P147

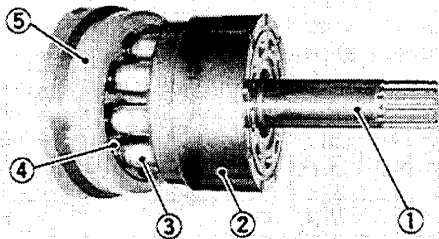

O306P003

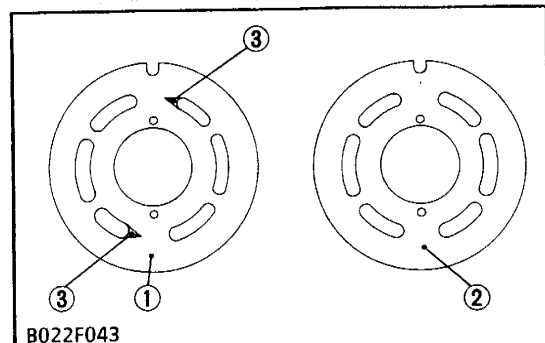

B022F043

■ IMPORTANT

- Valve plate of the pump (with two notches) should be mounted on the pump side of the port block.
- The notch side of pump valve plate should be directed to the side of the pump cylinder block.

- | |
|-----------------------|
| (1) Pump Valve Plate |
| (2) Motor Valve Plate |
| (3) Notch |

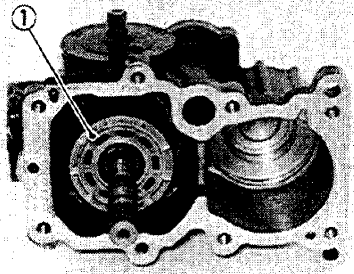

0303P037

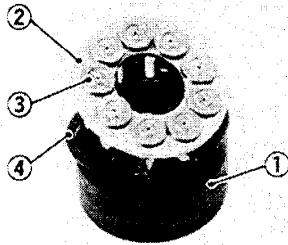

0011P146

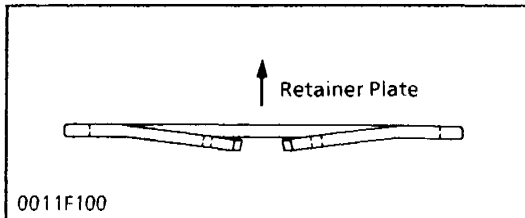

0011F100

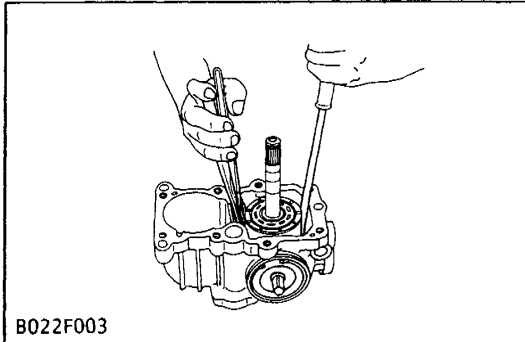

B022F003

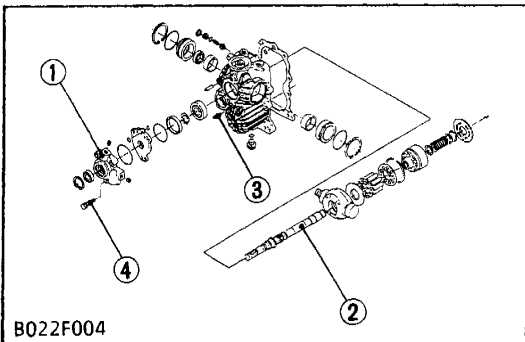

B022F004

Pump Cylinder Block

1. Remove the internal snap ring retaining the retainer plate of pump.
2. Slide out pump cylinder block (1) with pistons (3) retainer plate (2) and internal snap ring (4).
3. Draw out the thrust plate from the variable swashplate.

(When reassembling)

- Check that internal snap ring (4) faces correct in the direction, and install it to pump swashplate.
- Squeeze the snap ring (4) and slip into the hole its arc first by pushing down with a screwdriver to fit surely.

- | | |
|-------------------------|---------------|
| (1) Pump Cylinder Block | (3) Piston |
| (2) Retainer Plate | (4) Snap Ring |

Charge Pump and Input Shaft

1. Remove the screws (4) for retaining the charge pump case (1).
2. Tapping the rear end of the input shaft (2) with a soft hammer, separate the charge pump case (1) with the input shaft (2) from the case.
3. Remove two dowel pins (3).

Tightening torque	Charge pump case to case	23.5 to 27.5 N·m 2.4 to 2.8 kgf·m 17.4 to 20.3 ft-lbs
-------------------	--------------------------	---

- | | |
|----------------------|---------------|
| (1) Charge Pump Case | (3) Dowel Pin |
| (2) Input Shaft | (4) Screw |

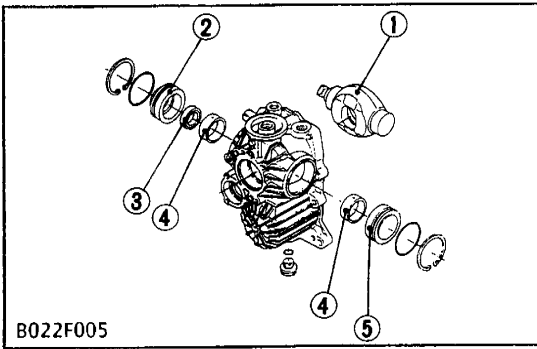

B022F005

Cover "A", "B" and Trunnion Shaft

1. Remove the internal snap ring.
2. Tap the trunnion shaft (1) using a soft hammer to create a clearance between the case and the cover "A" (2). Then, pry the cover "A" (2) open with a screw-driver. Pry the cover "B" (5) in the same way.
3. Pull out the trunnion shaft (1).

- (1) Trunnion Shaft
- (2) Cover A
- (3) Oil Seal
- (4) Seam of Bearing
- (5) Cover B

SERVICING

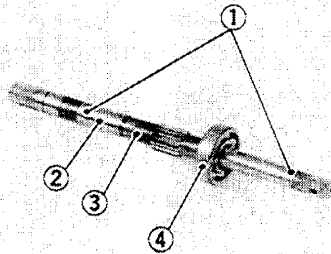

0011P132

Input Shaft

1. Pull out input shaft (3) with the bearing on it from the charge pump case.
2. Check the seal surface (1), the bearing surface (2) and the bearing (4).
3. If the shaft is rough or grooved, replace.
4. If the bearing is worn, replace.

- (1) Seal Surface
- (2) Bearing Surface
- (3) Input Shaft
- (4) Bearing

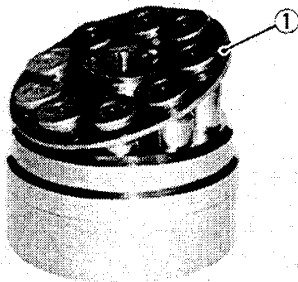

0306P008

Cylinder Block Bore and Pistons

1. Lift all the pistons gently with the retainer plate (1).
2. Check the pistons for their free movement in the cylinder block bores.
3. If the piston or the cylinder block bore is scored, replace the cylinder block assembly.

Clearance between piston and bore	Factory spec.	0.02 mm 0.0008 in.
-----------------------------------	---------------	-----------------------

- (1) Retainer Plate

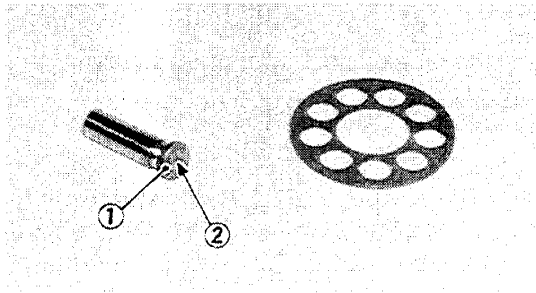

0306P009

Piston Slipper and Retainer Plate

1. Check the slipper (1) for flatness.
2. If rounded, replace.
3. Measure the thickness of piston slipper.
4. If the measurement is less than the allowable limit, replace.
5. Check the lubricant hole (2) for clogging.
6. If clogged, open hole with compressed air.

Thickness of slipper	Factory spec.	3.00 mm 0.118 in.
	Allowable limit	2.90 mm 0.114 in.

(1) Piston Slipper

(2) Lubricant Hole

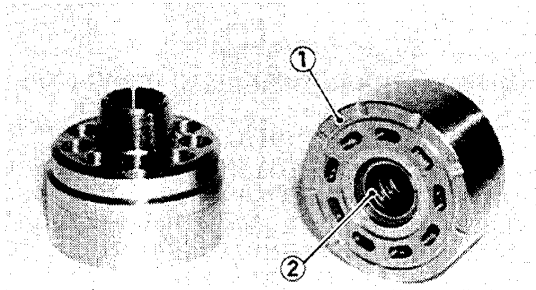

0306P010

Cylinder Block Face

1. Check the polished face (1) of cylinder block for scoring.
2. If scored, replace the cylinder block assembly.
3. Check the spring (2) for breakage.
4. If broken, replace the cylinder block assembly.

(1) Polished Face

(2) Spring

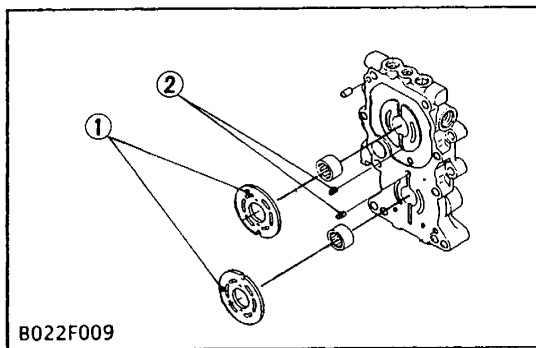

B022F009

Valve Plate

1. Check the engagement of the valve plate (1) and the dowel pin (2).
2. Pushing the valve plate against the dowel pin, lift it to remove.
3. Check the valve plate for foreign particles.
4. Clean the valve plate and dry with compressed air.
5. Check the valve plate for scratches, wear and erosion.
6. If worn or scored, replace.

NOTE

- Run a fingernail across the valve plate surface. If worn, it will be felt. After checking, coat them with hydrostatic transmission oil.

(1) Valve Plate

(2) Dowel Pin

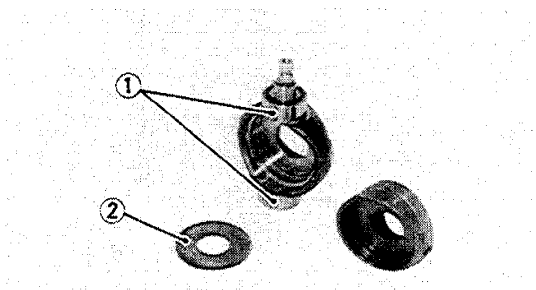

0319P258

Swashplate and Thrust Plate

1. Check the bearing surface of trunnion shaft (1) for scratches and excessive wear.
2. If worn or scored, replace.
3. Check the thrust plate (2) for scratches and excessive wear.
4. If worn or scored, replace.

(1) Bearing Surface

(2) Thrust Plate

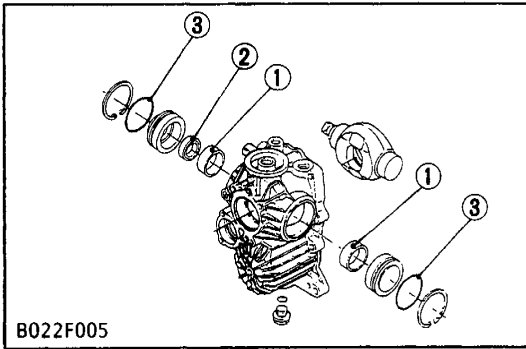

Trunnion Shaft Cover

1. Check the bearings (1) for scratches and excessive wear.
2. If worn or scored, replace.
3. Check the oil seal (2) and the O-ring (3) for damage.

■ **NOTE**

- After checking, coat the bearing with hydrostatic transmission oil, and the oil seal lip and the O-ring with grease.

- | | |
|--------------|------------|
| (1) Bearing | (3) O-ring |
| (2) Oil Seal | |

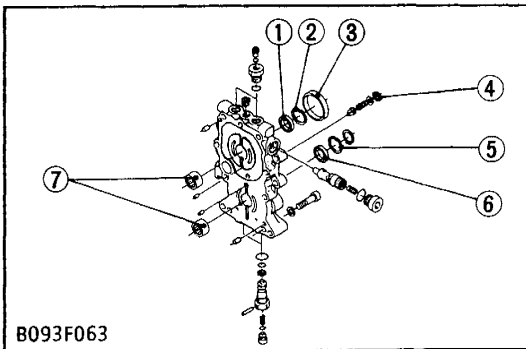

Oil Seal and Bearing

1. Remove the collar (3) and internal snap ring (2), (5) and check the oil seals (1), (6) for damage.
2. Check the bearings (7) for wear.
3. If the bearings are worn, replace.

■ **NOTE**

- After checking, coat the bearing with hydrostatic transmission oil and the oil seal lip with grease.
- When replacing the bearing, press it in the port block so that its mark faces outside and 4.5 mm (0.177 in.) of it remains above the machined surface.
- When reassembling, always replace the oil seal as follows.

- | | |
|------------------------|------------------------|
| (1) Oil Seal | (5) Internal Snap Ring |
| (2) Internal Snap Ring | (6) Oil Seal |
| (3) Collar | (7) Needle Bearing |
| (4) Internal Snap Ring | |

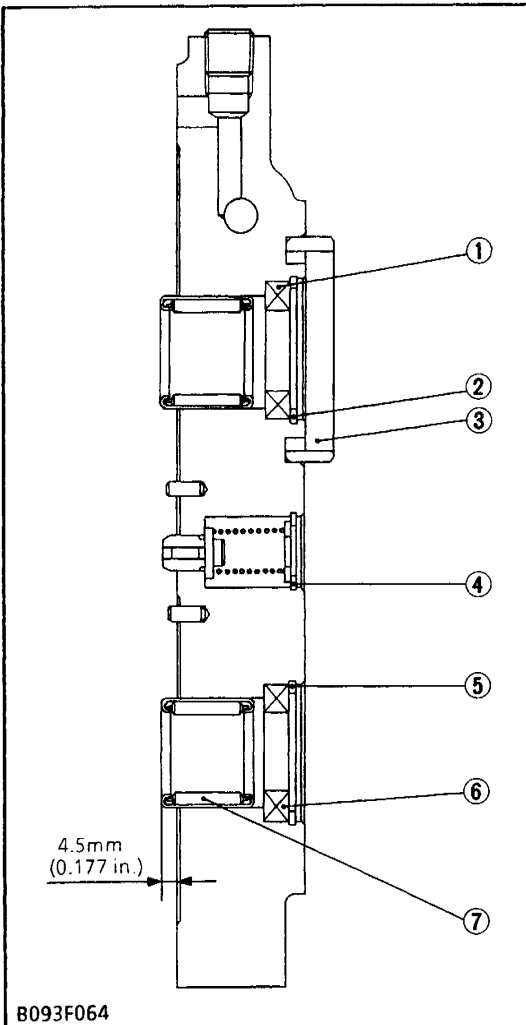

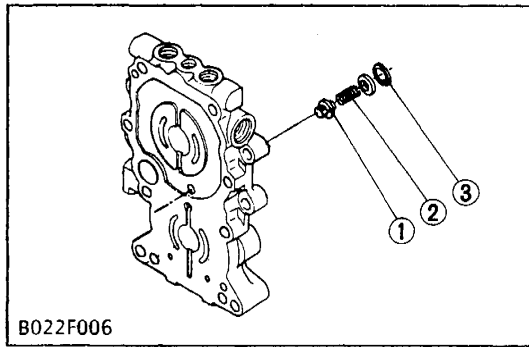

B022F006

Case Relief Valve

1. Check the valve and the spring for excessive wear and breakage.
2. If worn or broken, replace.

Length of valve spring	Factory spec.	23.0 mm, 0.906 in. (free)
		15.0 mm, 0.591 in. (load 29.4 N, 3.00 kgf, 6.62 lbs)

(1) Case Relief Valve
(2) Spring

(3) Internal Snap Ring

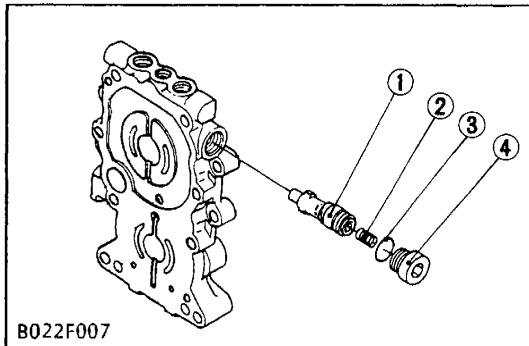

B022F007

Check and High Pressure Relief Valve

1. Check the valve (1) for scratches and damage.
2. Check the valve seat in the port block for damage.
3. Check the spring (2) for breakage and wear.
4. If anything unusual, replace the check and high pressure relief valve complete assembly.

Length of valve spring	Factory spec.	18.2 mm, 0.717 in. (free)
		14.5 mm, 0.571 in. (load 3.43 N, 0.35 kgf, 0.77 lbs)
Length of valve spring	Factory spec.	12.4 mm, 0.488 in. (free)
		10.5 mm, 0.413 in. (load 41.87 N, 4.27 kgf, 9.41 lbs)
Tightening torque	Cap nut	53.9 to 63.7 N·m 5.5 to 6.5 kgf·m 39.8 to 47.0 ft·lbs

(1) Valve
(2) Spring
(3) O-ring
(4) Cap Nut

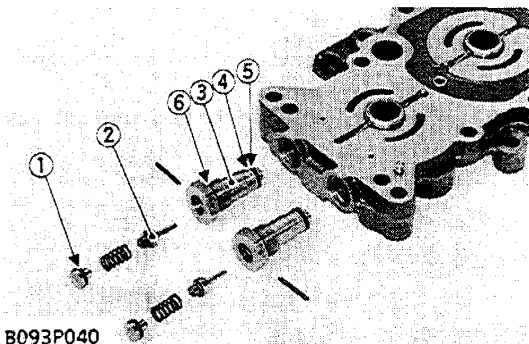

B093P040

Neutral Valve

1. Remove the valve assembly and disassemble it.
2. Check the neutral valve (2) for their free movement on or in the valve body (3).
3. If the valve surface is scored, replace.
4. Check the holes of the valve body (3) and the neutral valve (2) for clogging.
5. If clogged, open hole with compressed air.
6. Check the O-rings (1), (5) and the backup ring (4) for scratches and damage.
7. Check the springs for breakage and wear.
8. If anything unusual, replace.

Length of valve spring	Factory spec.	18.4 mm, 0.7244 in. (free)
		13.9 mm, 0.5472 in. (load 43.2 N, 4.4 kgf, 9.7 lbs)

(1) O-ring
(2) Neutral Valve
(3) Valve Body
(4) Backup Ring
(5) O-ring
(6) O-ring

NOTE

- When reassembling, replace the O-ring and the backup rings.

Tightening torque	Valve body to case	53.9 to 63.7 N·m 5.5 to 6.5 kgf·m 39.8 to 47.0 ft·lbs
-------------------	--------------------	---

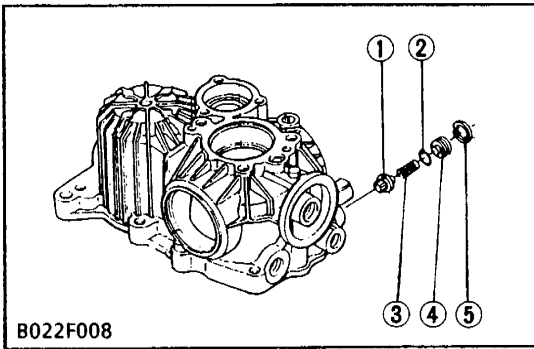

- (1) Valve
- (2) O-ring
- (3) Spring
- (4) Spring Holder
- (5) Snap Ring

Charge Relief Valve

1. Remove the internal snap ring (5) and draw out the spring holder (4) after pushing it a several time.
2. Check the spring (3) for breakage and wear.
3. Check the O-ring (2) for damage.
4. If anything unusual, replace.

NOTE

- Install the internal snap ring with its sharp edge facing outside.

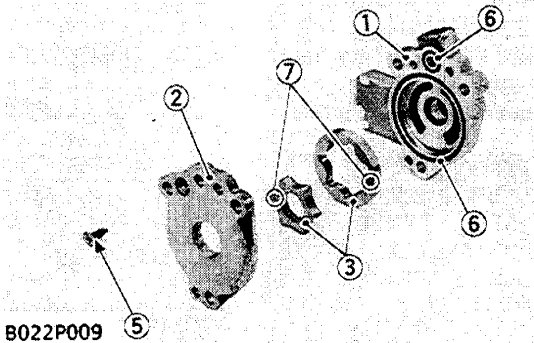

B022P009

Charge Pump

1. Check the charge pump case (1), the plate (2) and the gerotor set (3) for scratches and wear.
2. If scratched or worn, replace the charge pump complete assembly.
3. Measure the side clearance referring to the figure.
4. If the clearance exceeds the factory specification, replace the charge pump complete assembly.

Side clearance	Factory spec	0.030 to 0.060 mm 0.0012 to 0.0024 in.
----------------	--------------	---

NOTE

- When reassembling, replace the O-rings (6) and the oil seals, and grind the surface of the plate (2) and the charge pump case (1) with finest oil stone.

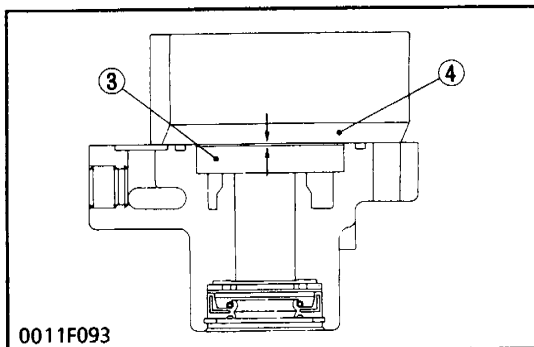

0011F093

- (1) Charge Pump Case
- (2) Plate
- (3) Gerotor Set
- (4) Straight Edge
- (5) Screw
- (6) O-ring
- (7) Marks

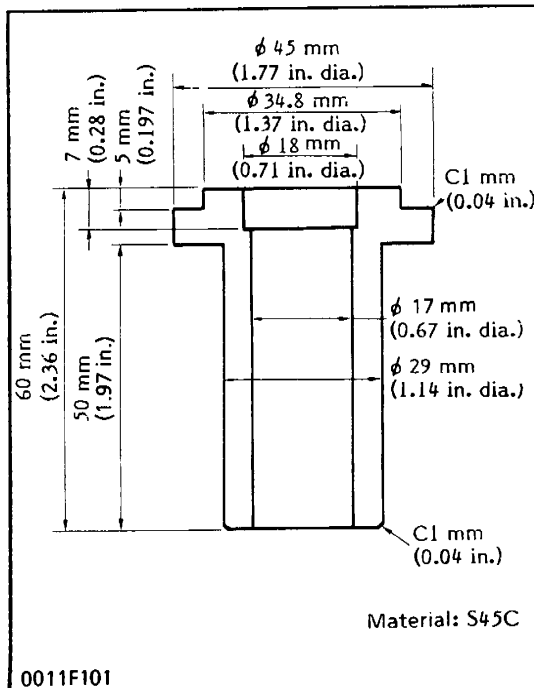

0011F101

Special Tool A for Pressing Oil Seal

1. Make the special tools shown in figure and reassemble the charge pump according to following directions.

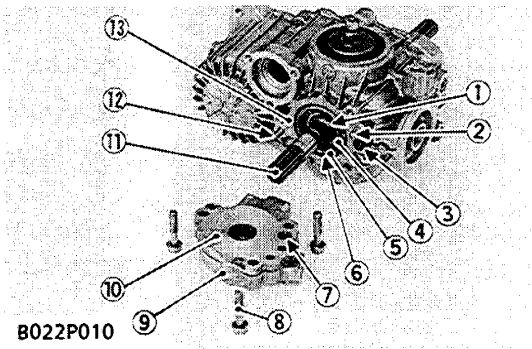

Reassembling

1. Place the swashplate in neutral and install the input shaft (11) to the case (13) with the bearing (4) on it.
2. Install the collar (5) on the bearing (4).
3. Coat the O-rings (3), (6) with hydrostatic transmission oil and install them on the case (13).
4. Install the dowel pins (2), (12).
5. Press the oil seal in the charge pump case, using the special tool A, until it is 4 mm (0.157 in.) below the machined surface.
6. Install the internal snap ring with its sharp edge facing outside.
7. Coat the O-rings with hydrostatic transmission oil and install them on the charge pump case (9).
8. Install the gerotor set on the charge pump case and set the plate (10) to it.
9. Set the screw (7) and tighten it, aligning each hole on the plate to each hole on the charge pump case, each other.
10. Install this charge pump assembly to the input shaft, aligning the gerotor splines to the shaft splines and two holes to two dowel pins.
11. Tighten three screws (8).

Tightening torque	Charge pump case to case	23.5 to 27.5 N·m 2.4 to 2.8 kgf·m 17.4 to 20.3 ft·lbs
-------------------	--------------------------	---

- | | |
|------------------------|----------------------|
| (1) External Snap Ring | (8) Screw |
| (2) Dowel Pin | (9) Charge Pump Case |
| (3) O-ring | (10) Plate |
| (4) Bearing | (11) Input Shaft |
| (5) Collar | (12) Dowel Pin |
| (6) O-ring | (13) Case |
| (7) Screw | |

CONTENTS

MECHANISM

6 FRONT AXLE	CM.6-1
■ Bi-speed Turn (B2150-B2150HST)	CM.6-1

SERVICING

6 FRONT AXLE	CS.6-1
[B2150-B2150HST BI-SPEED TURN]	
TROUBLESHOOTING	CS.6-1
SERVICING SPECIFICATIONS	CS.6-1
TIGHTENING TORQUES	CS.6-2
CHECKING, DISASSEMBLING AND SERVICING	CS.6-2
CHECKING AND ADJUSTING	CS.6-2
DISASSEMBLING AND ASSEMBLING	CS.6-3
SERVICING	CS.6-6

TO THE READER

In this section, the main additional functions of BI-SPEED TURN for B2150-B2150HST tractor are explained separately in two items, "Mechanism" and "Servicing".

As for the items which are not explained in this section, refer to Workshop Manual for B1550-B1750-B2150-B1550HST-B1750HST-B2150HST.

■ Mechanism

Information on construction and function are included for B2150-B2150HST BI-SPEED TURN tractor. This part should be understood before proceeding with troubleshooting, disassembling and servicing.

■ Servicing

For B2150-B2150HST BI-SPEED TURN tractor, there are troubleshooting, servicing specification lists, checking and adjusting, disassembling and assembling, and servicing which cover procedures, precautions, factory specifications and allowable limits.

All information, illustrations and specifications contained in this manual are based on the latest production information available at the time of publication.

The right is reserved to make changes in all information at any time without notice.

July '90

6 FRONT AXLE

■ Bi-speed Turn (B2150-B2150HST)

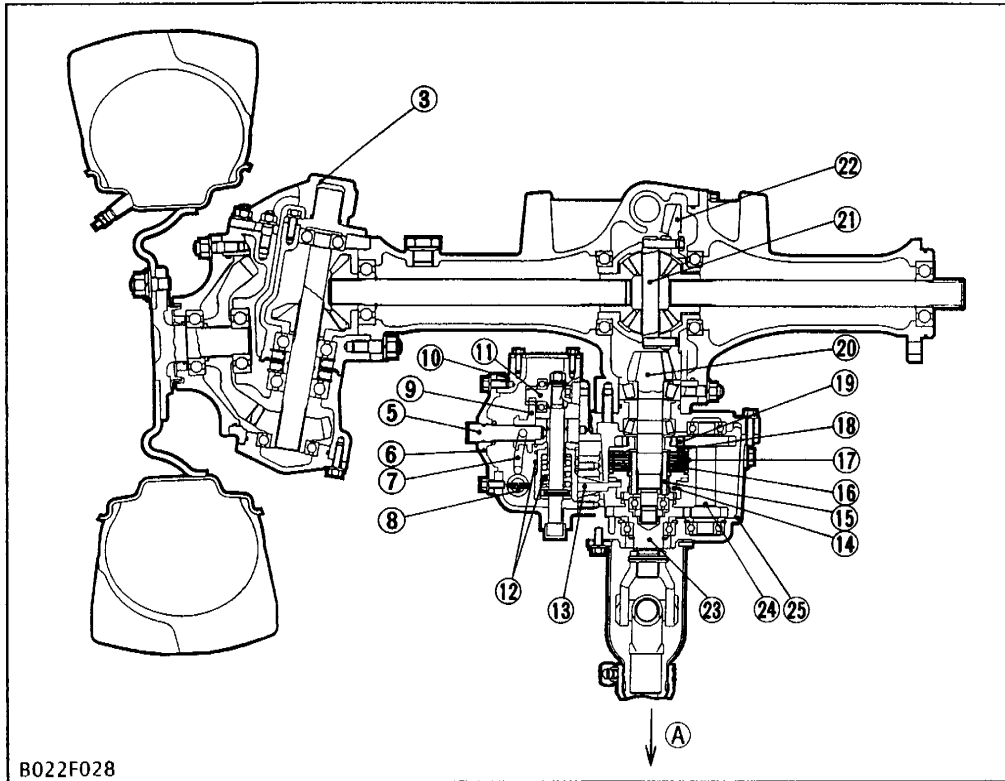

- (1) Bi-speed Turn Change Lever
 - (2) Bi-speed Turn Change Rod
 - (3) Knuckle Arm
 - (4) Shift Rod
 - (5) Shift Lever
 - (6) Shift Lever Fulcrum
 - (7) Change Fork
 - (8) Change Lever
 - (9) Shift Cam
 - (10) Bi-speed Turn Case
 - (11) Shift Roller Shaft
 - (12) Spring
 - (13) Bi-speed Turn Shift Fork
 - (14) Shifter
 - (15) Coupling
 - (16) Clutch Disc
 - (17) Friction Plate
 - (18) Clutch Drum
 - (19) 17T Gear
 - (20) Spiral Bevel Pinion Shaft
 - (21) Front Differential Assembly
 - (22) Bevel Gear
 - (23) Gear Shaft
 - (24) Gear Shaft
 - (25) Bi-speed Turn Gear Case
- A : Front

B022F028

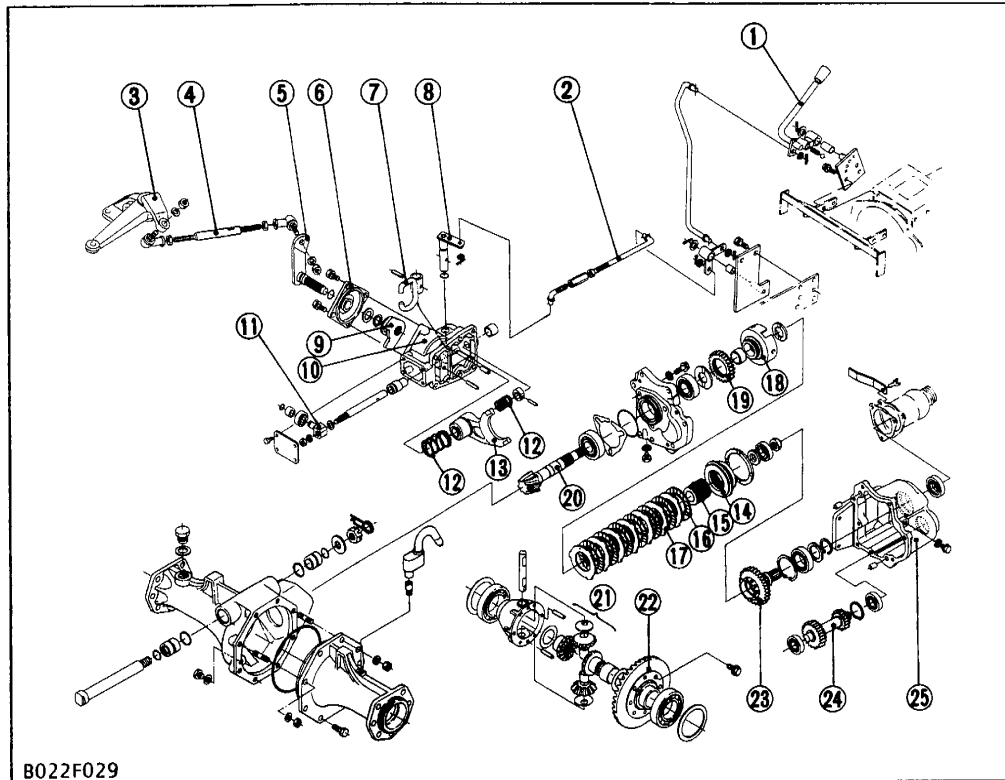

B022F029

The front axle with bi-speed turn of B2150 and B2150HST is constructed as shown above. Front wheel speed change mechanism, which is located in the bi-speed turn gear case (25) and bi-speed turn

case (10), consists of the bi-speed turn change lever (1), shift rod (4), shift cam (9), shift fork (13), bi-speed turn clutch assembly (14 to 18), gears (19) (23) (24) and so on.

■ Bi-speed Turn Power Train

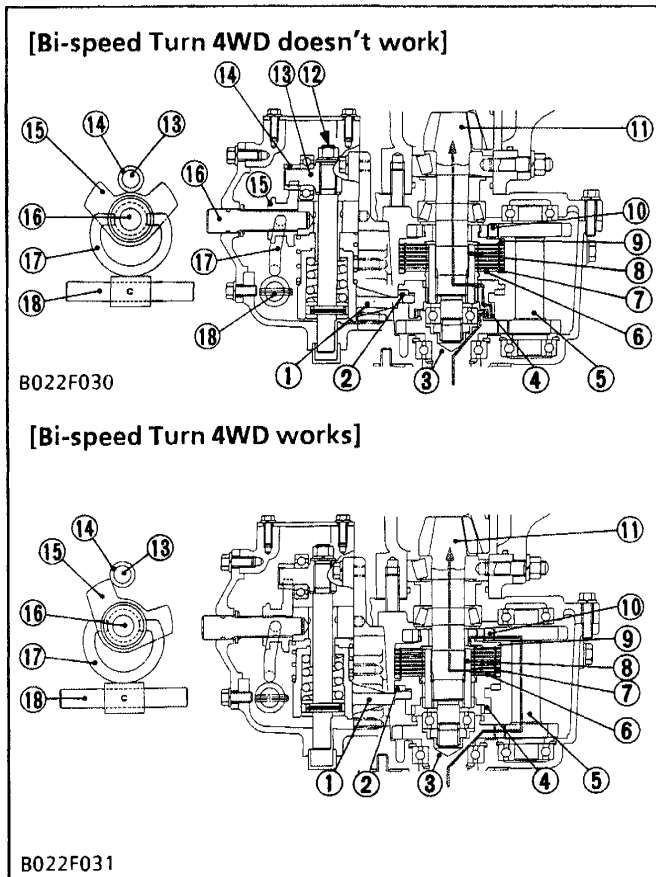

Bi-speed clutch is mechanically engaged when front wheel reaches approximately 28 degree turning angle.

This bi-speed turn front wheel speed is 1.7 times higher than the standard front wheel speed.

■ Standard 4WD

21T Gear Shaft (3) → Shifter (4) → Bi-speed Turn Coupling (8) → Spiral Bevel Pinion Shaft (11) → Front Axle.

■ Bi-speed Turn 4WD

21T Gear Shaft (3) → 14T-10T Gear Shaft (5) → 17T Gear (10) → Bi-speed Turn Clutch Drum (9) → Friction Plate (7) → Clutch Disc (6) → Bi-speed Turn Coupling (8) → Spiral Bevel Pinion Shaft (11) → Front Axle.

- | | |
|-------------------------------|--------------------------------|
| (1) Shift Fork | (10) 17T Gear |
| (2) Shifter Collar | (11) Spiral Bevel Pinion Shaft |
| (3) 21T Gear Shaft | (12) Shift Rod |
| (4) Shifter | (13) Shift Roller Shaft |
| (5) 14T-10T Gear Shaft | (14) Shift Roller |
| (6) Clutch Disk | (15) Shift Cam |
| (7) Friction Plate | (16) Shift Lever |
| (8) Bi-speed Turn Coupling | (17) Change Fork |
| (9) Bi-speed Turn Clutch Drum | (18) Change Lever |

■ Bi-speed Cam

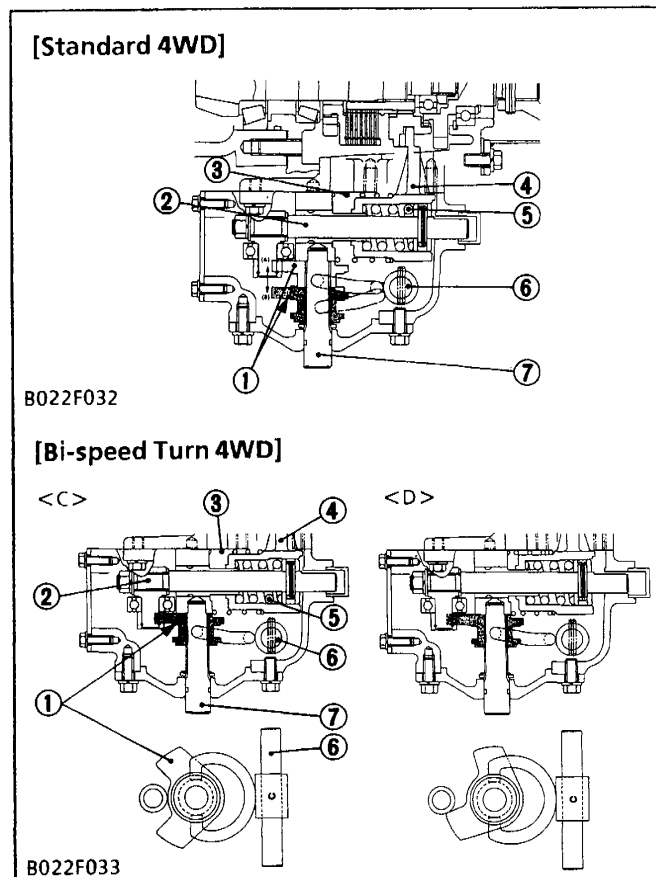

Bi-speed turn 4WD and standard 4WD positions are selected by change lever (6) to move the position of shift cam (1). This lever is operated by the bi-speed turn change lever located on the right side of the clutch housing.

■ Standard 4WD Position

The bi-speed turn change lever is shifted to the "OFF" position.

The shift cam (1) is free to turn, so that the shift rod (2) and shift fork (4) are remained in standard 4WD position by springs (3), (5).

■ Bi-speed Turn 4WD Position

The bi-speed turn change lever is shifted to the "ON" position.

When the steering wheel is turned more than approx. 28 degree turning angle, the shift lever (7) and shift cam (1) are turned together. This cam make the shift rod (2) move the arrow direction so that the shifter is engaged with the bi-speed turn clutch.

When the steering wheel is turned less than approx. 28 degree turning angle, the shift rod doesn't move in spite of the cam rotation.

- | | |
|---------------------------------|-------------------------|
| (1) Shift Cam | (5) Spring |
| (2) Shift Rod | (6) Change Lever |
| (3) Spring | (7) Shift Lever |
| (4) Shift Fork | |
| (A) Bi-speed turn "ON" | (B) Bi-speed turn "OFF" |
| (C) Less than 28° turning angle | (D) More than 28° |

6 FRONT AXLE

TROUBLESHOOTING

Symptom	Probable Cause	Solution	Reference Page
Bi-speed Turn System Does Not Operate or Slipping	<ul style="list-style-type: none"> ● Bi-speed turn clutch friction torque too low ● Shift fork spring weaken or damaged ● Shift fork deformed, worn or broken ● Change fork deformed or broken ● Shift cam rusted ● Shift roller worn ● Clutch disc worn ● Friction plate worn or deformed ● Gear broken ● Shifter collar worn ● Wrong assembly of shift cam ● Wrong linkage adjustment 	Adjust Replace Replace Replace Repair or Replace Replace Replace Replace Replace Replace Reinstall Readjust	CS.6-6 CS.6-7 CS.6-6 CS.6-4 CS.6-3 CS.6-4 CS.6-5, 7 CS.6-5, 7 CS.6-5 CS.6-5 CS.6-4 CS.6-2
Bi-speed Turn Does Not Return to Standard 4WD Position	<ul style="list-style-type: none"> ● Shift fork deformed ● Shift cam deformed ● Wrong linkage adjustment 	Replace Replace Readjust	CS.6-6 CS.6-3, 4 CS.6-2
Different Bi-speed Turn Starting Angle Between Right and Left turning	<ul style="list-style-type: none"> ● Shift rod improperly adjusted ● Shift lever and shift cam improperly assembled ● Shift cam worn 	Adjust Reassemble Replace	CS.6-2 CS.6-4 CS.6-3, 4

SERVICING SPECIFICATIONS

Item		Factory Specification	Allowable Limit
Bi-speed Turn Clutch	Dynamic Friction Torque on front drive shaft	83 to 118 N·m 8.5 to 12 kgf·m 61 to 87 ft·lbs	—
Shift Fork to Shifter Groove (with Shifter Collar)	Clearance	0.1 to 0.7 mm 0.004 to 0.028 in.	1.0 mm 0.04 in.
Bi-speed Turn Spring (short)	Free Length	32.5 to 33.5 mm 1.280 to 1.319 in.	—
	Maximum Setting Length	25.5 mm, 1.00 in. (load 1613 N, 164.5 kgf·m, 362.7 lbs)	25.5 mm, 1.00 in. (load 1411 N, 143.9 kgf, 317.4 lbs)
Bi-speed Turn Spring (long)	Free Length	52.0 mm, 2.047 in.	—
	Setting Length	35.0 mm, 1.378 in. (load 86.3 N, 8.8 kgf, 19.4 lbs)	35.0 mm, 1.378 in. (load 75.5 N, 7.7 kgf, 17.0 lbs)
Bi-speed Turn Clutch Disc	Thickness	1.7 to 1.9 mm 0.067 to 0.075 in.	1.4 mm 0.055 in.
Bi-speed Turn Friction Plate	Thickness	0.95 to 1.05 mm 0.037 to 0.041 in.	0.8 mm 0.0315 in.

TIGHTENING TORQUES

Tightening torques of screws and nuts on the table below are especially specified.

Item	N·m	kgf·m	ft·lbs
Shift lever fulcrum mounting screws	17.7 to 20.5	1.8 to 2.1	13.0 to 15.2
Bi-speed turn case mounting screws	23.6 to 27.4	2.4 to 2.8	17.4 to 20.2
Bi-speed turn gear case mounting screws	23.6 to 27.4	2.4 to 2.8	17.4 to 20.2
Bearing holder mounting screws	48.1 to 55.8	4.9 to 5.7	35.5 to 41.2
Spiral bevel pinion shaft staking nut	127 to 167	13 to 17	94.0 to 123.0

CHECKING, DISASSEMBLING AND SERVICING

CHECKING AND ADJUSTING

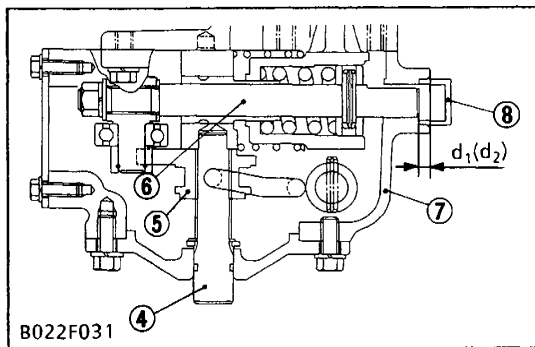
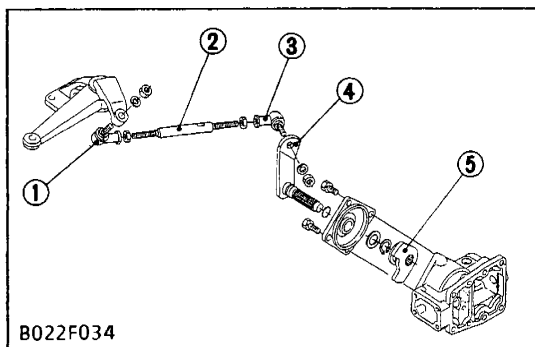

Bi-speed Turn Shift Rod

1. Remove the cap (8).
2. Steer the wheels to the extreme right, and measure the depth (d_1) of the shift rod (6) from the edge of the bi-speed turn case with a depth gauge.
3. Steer the wheels to the extreme left, and measure the depth (d_2) of the shift rod (6) from the edge of the bi-speed turn case with a depth gauge.
4. Adjust these depths with the shift rod (2) so that the difference ($d_1 \sim d_2$) is less than 1 mm (0.039 in.).
5. After adjustment, be sure to tighten the lock nut and drive the tractor to check this operation.

Depth (d_1 and d_2)	Factory spec.	11.5 to 13.5 mm 0.45 to 0.53 in.
Bi-speed turn steering angle *(R & L)	Factory spec.	26° to 30°

* When the wheels are steered to this, the bi-speed turn starts to work.

NOTE

- When the wheels are steered to the max. angle, the shift rod end (1), (3) should have a play.

- | | |
|----------------------|------------------------|
| (1) Shift Rod End RH | (5) Shift Cam |
| (2) Shift Rod | (6) Shift Rod |
| (3) Shift Rod End LH | (7) Bi-speed Turn Case |
| (4) Shift Lever | (8) Cap |

Bi-speed Turn Change Rod

1. Shift the bi-speed turn change lever (1) to the "ON" position.
2. Adjust the bi-speed turn change rod (3) length with the turnbuckle so that this rod is free between two rod ends while keeping the change lever (2) on the "ON" position. (that is, the rod end is able to be reset smoothly after taking it off from the change lever (2).)

- | | |
|--------------------------------|------------------------------|
| (1) Bi-speed Turn Change Lever | (3) Bi-speed Turn Change Rod |
| (2) Change Lever | |

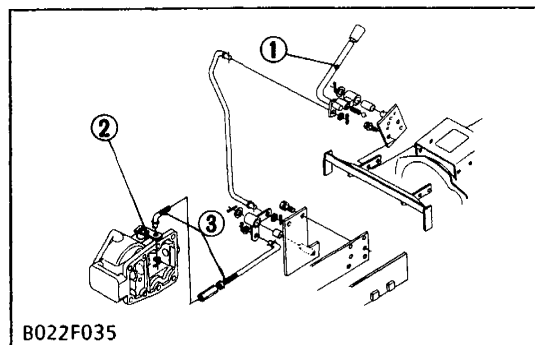

DISASSEMBLING AND ASSEMBLING

Draining Front Axle Diff. Case Oil

1. Remove the drain plug to drain oil from the front axle differential case and bi-speed turn case.

Place	Capacity	Lubricants
Front axle diff. case	2.9 ℓ 3.06 U.S. qts. 2.55 Imp. qts.	Gear oil SAE 80 or SAE 90

NOTE

- Remove the filling port plug to drain oil completely.

Joint Case

1. Remove the stay (2) and joint case (4).
2. Tap out the spring pin, and remove the joint assembly (3) from the spiral bevel pinion shaft.

(When reassembling)

- The cap (1) should be firmly held by the stay (2).

- (1) Cap (3) Joint Assembly
(2) Stay (4) Joint Case

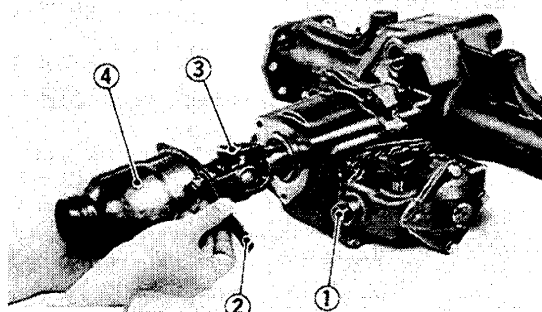

B022P002

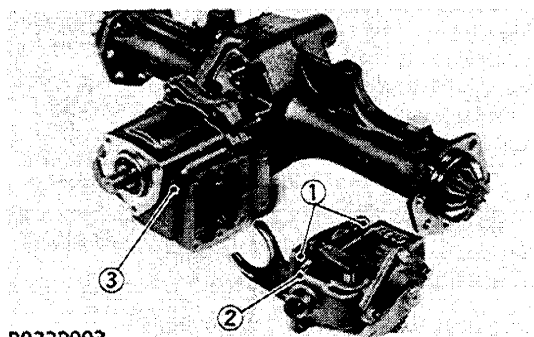

B022P003

- (1) Screws (3) Bi-speed Turn Gear Case
(2) Bi-speed Turn Case

Separation of Bi-speed Turn Case

1. Remove the bi-speed turn case mounting screws (1) and separate the bi-speed turn case (2) from the bi-speed turn gear case (3).

(When reassembling)

- Install the bi-speed turn case to the bi-speed turn gear case, noting the position of shifter collar. (Place the shifter collar between shift fork and shifter)

Tightening torque	Bi-speed turn case mounting screw	23.6 to 27.4 N·m 2.4 to 2.8 kgf·m 17.4 to 20.2 ft·lbs

- After shifting the bi-speed turn shifter to the spiral bevel pinion shaft side, mount the shift fork on the shifter and install the case to the gear case.

Shift Cam

1. Remove the shift lever fulcrum (2) with the shift lever and shift cam (5).
2. Remove the external snap ring (4) and collar (3).
3. Remove the shift lever (1).

NOTE

- The white marks is painted on the shift lever (1) for aligning the shift cam.

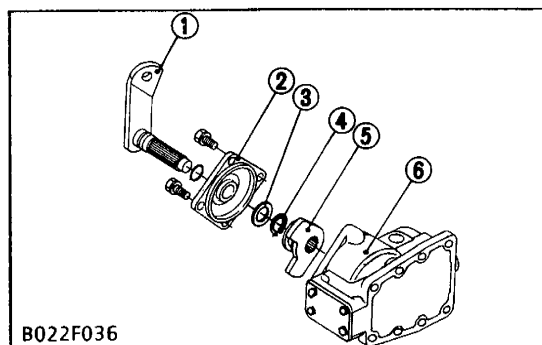

B022F036

- (1) Shift Lever (6) Bi-speed Turn Case
(2) Shift Lever Fulcrum (7) Center Line
(3) Collar (8) White Painted (4th
(4) External Snap Ring Tooth Base from the
(5) Shift Cam center)

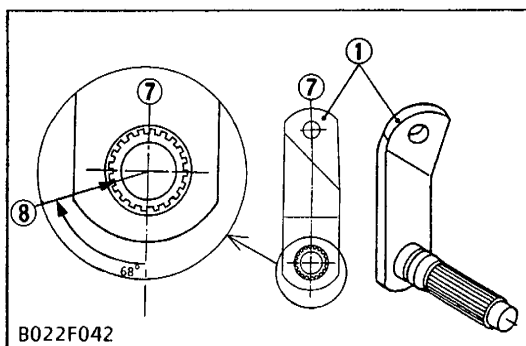

B022F042

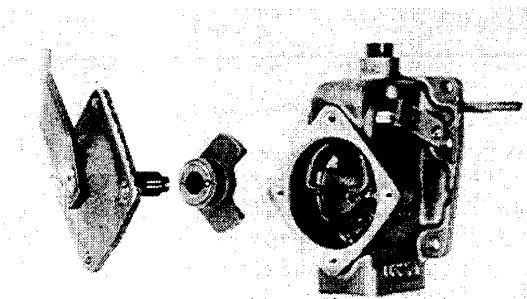

B022P004

(When reassembling)

- When installing the shift cam, be sure to align the marks on the shift cam and shift lever.
- The change lever should be set as shown in page CS.6-2.

Tightening torque	Shift lever fulcrum mounting screw	17.7 to 20.5 N·m 1.8 to 2.1 kgf·m 13.0 to 15.2 ft·lbs
-------------------	------------------------------------	---

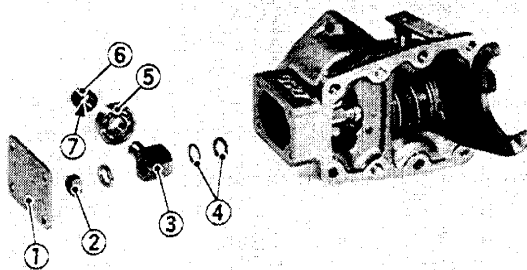

B022P005

(When reassembling)

- Install the shift roller shaft, aligning the mark on the shift rod to the center of the ball bearing.

Shift Roller Shaft

1. Remove the cover (1).
2. Remove the nut (2) and the shift roller shaft ass'y.
3. Tap out the shift roller shaft (3), while holding the bearing (5) to remove the shift roller (6). The retainer ring (7) is mounted inside of the roller.

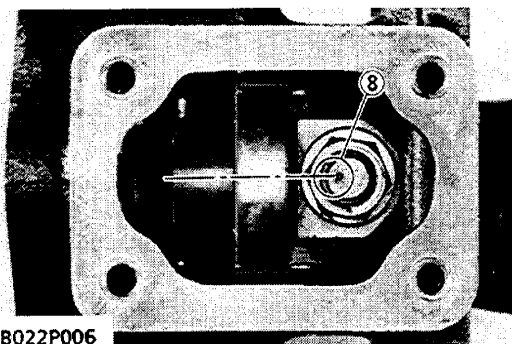

B022P006

- (1) Cover
- (2) Nut
- (3) Shift Roller Shaft
- (4) Adjusting Shim
- (5) Ball Bearing
- (6) Shift Roller
- (7) Retainer Ring
- (8) Mark

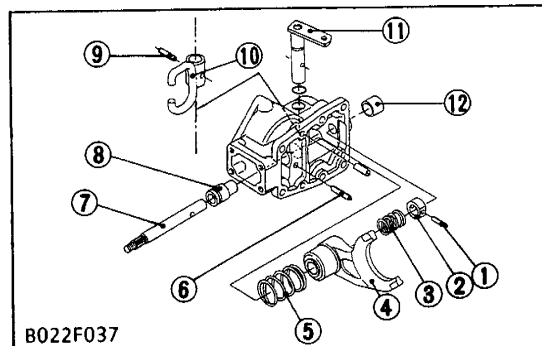

B022F037

Shift Fork, Shift Rod and Change Lever

1. Push the shift fork to the front till the spring pin (1) can be seen and tap out the spring pin (1).
2. Remove the cap (12) and tap out the shift rod (7) to the front.
3. Tap out the spring pin (6).
4. Tap out the shift rod collar (8) by the rod to the front.
5. Take off the shift fork (4), springs (3) (5) and pressure collar (2) together.
6. Tap out the spring pin (9), using the screw hole for the fulcrum mounting screw on the case. Remove the change lever (11) and change fork (10).

- (1) Spring Pin
- (2) Pressure Collar
- (3) Spring
- (4) Shift Fork
- (5) Spring
- (6) Spring Pin
- (7) Shift Rod
- (8) Shift Rod Collar
- (9) Spring Pin
- (10) Change Fork
- (11) Change Lever
- (12) Cap

(When reassembling)

- Apply adhesive to the cap.

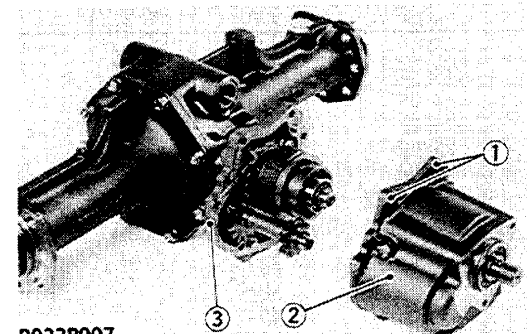

B022P007

Separation of Bi-speed Turn Gear Case

1. Remove the bi-speed turn gear case mounting screws (1).
2. Separate the bi-speed turn gear case (2) from the bearing holder (3).

(When reassembling)

- Apply liquid gasket (Three Bond 1208 D or equivalent) to the bi-speed turn gear case.

Tightening torque	Bi-speed turn gear case mounting screw	23.6 to 27.4 N·m 2.4 to 2.8 kgf·m 17.4 to 20.2 ft·lbs
-------------------	--	---

- (1) Bi-speed Turn Gear Case Mounting Screws
- (2) Bi-speed Turn Gear Case
- (3) Bearing Holder

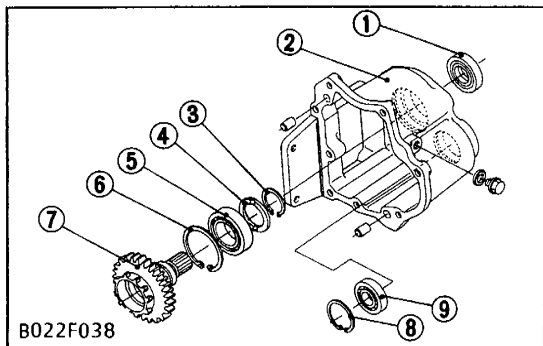

Ball Bearing and Oil Seal

1. Remove the oil seal (1) and remove the external snap ring (3) and thrust collar (4).
2. Tap out the gear shaft (7).
3. Remove the internal snap ring (6) and remove the bearing (5) from the bi-speed turn gear case (2).
4. Remove the internal snap ring (8) and ball bearing (9) from the bi-speed turn case (2).

(When reassembling)

- Apply grease to the oil seal.

- | | |
|-----------------------------|------------------------|
| (1) Oil Seal | (6) Internal Snap Ring |
| (2) Bi-speed Turn Gear Case | (7) Gear Shaft |
| (3) External Snap Ring | (8) Internal Snap Ring |
| (4) Thrust Collar | (9) Ball Bearing |
| (5) Ball Bearing | |

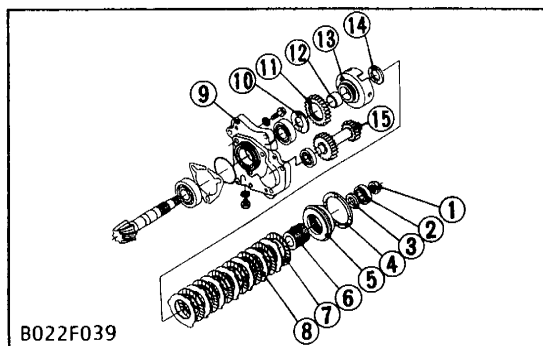

Bi-speed Turn Clutch Assembly

1. Put back the stakes of the nut (1) and remove it.
2. Pull out the ball bearing (2) with a puller and remove the plain washer (3) shifter collar (4) and shifter (5).
3. Remove the bi-speed turn coupling (6), clutch discs (7), friction plates (8), collar (14) and bi-speed turn clutch drum (13).
4. Remove the thrust collar (10), bi-speed turn gear (11) and inner ring (12) from the bi-speed turn clutch drum (13).
5. Remove the gear shaft (15).

(When reassembling)

- Apply molybdenum disulphid (Three bond 1901 or equivalent) to the inner ring.
- Replace the staking nut with a new one and tighten the nut and be sure to stake it.

- | | |
|----------------------------|--------------------------------|
| (1) Nut | (9) Bearing Holder |
| (2) Ball Bearing | (10) Thrust Collar |
| (3) Plain Washer | (11) Bi-speed Turn Gear |
| (4) Shifter Collar | (12) Inner Ring |
| (5) Shifter | (13) Bi-Speed Turn Clutch Drum |
| (6) Bi-Speed Turn Coupling | (14) Collar |
| (7) Clutch Disc | (15) Gear Shaft |
| (8) Friction Plate | |

Tightening torque	Staking nut	127 to 167 N·m 13 to 17 kgf·m 94.0 to 123.0 ft-lbs
-------------------	-------------	--

- After installing the gear shaft with the bearing, reinstall the bi-speed turn clutch ass'y.

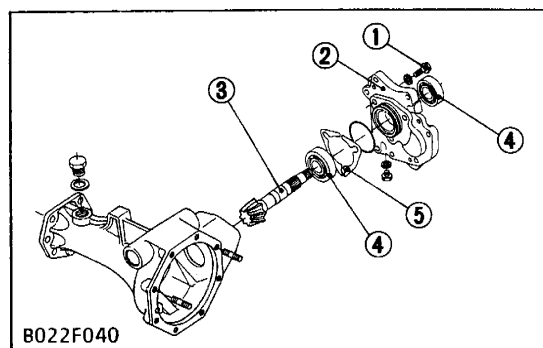

Spiral Bevel Pinion Shaft

1. Remove the bearing holder mounting screws (1).
2. Remove the bearing holder (2).
3. Tap out the spiral bevel pinion shaft (3) from the bearing holder (2).

(When reassembling)

Tightening torque	Bearing holder mounting screw	48.1 to 55.8 N·m 4.9 to 5.7 kgf·m 35.5 to 41.2 ft-lbs
-------------------	-------------------------------	---

- | | |
|-------------------------------|---------------------------|
| (1) Screw | (4) Taper Roller Bearings |
| (2) Bearing Holder | (5) Shims |
| (3) Spiral Bevel Pinion Shaft | |

- Adjust the backlash between the bevel gear and the spiral bevel pinion shaft with shims (5), after mounting the bi-speed turn clutch ass'y and tightening the nut.

SERVICING

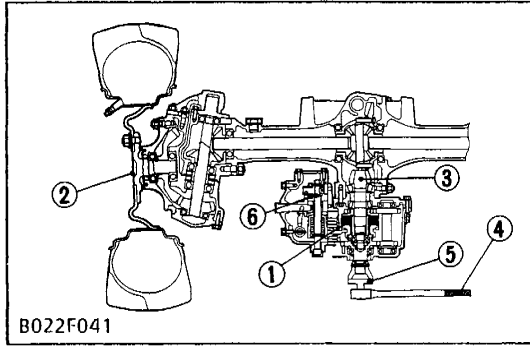

- B022F041
- (1) Bi-speed Turn Clutch
 - (2) Front Wheel Hub
 - (3) Spiral Bevel Pinion Shaft
 - (4) Torque Wrench
 - (5) Jig
 - (6) Shim

Bi-speed Turn Clutch Friction Torque

1. Disconnect the front drive shaft and remove the joint case and joint (1).
2. Engage the bi-speed turn change lever and fully turn the steering wheel to the left (or right).
3. Set the parking brakes and fix both front tires.
4. Set the torque wrench (4) with the special jig on the gear shaft.
5. When the bi-speed turn clutch is slipped, measure its torque.
6. If the torque is not within the factory specifications, adjust it with the shims (6).

Dynamic friction torque of bi-speed turn clutch	Factory spec.	83 to 118 N·m 8.5 to 12 kgf·m 61 to 87 ft-lbs
---	---------------	---

(Reference)

- Thickness of shims.
1.0 mm (0.039 in.), 1.5 mm (0.059 in.)
- Decreasing 1.0 mm (0.039 in.) shim changes the dynamic friction torque of the clutch by 1.5 to 2.5 kgf·m (10.8 to 18.1 ft-lbs, 14.7 to 24.5 N·m).
- When the dynamic friction torque of the bi-speed turn clutch is measured on the front axle wheel hub, its factory specification is as follows.

Dynamic friction torque of bi-speed turn clutch on the front axle wheel	Factory spec.	451.1 to 500.2 N·m 46 to 51 kgf·m 322.7 to 368.9 ft-lbs
---	---------------	---

■ IMPORTANT

- When the dynamic friction torque of the bi-speed turn clutch is readjusted, 1.5 mm shim should be always mounted between the shift rod and the shift roller shaft.

■ NOTE

- Check the springs, clutch discs and friction plates if the correct torque can't be adjusted.

Clearance between Shift Fork and Shifter Groove

1. Place the shift fork in the shifter groove and measure the clearance with a feeler gauge.
2. If the clearance exceeds the allowable limit, replace.

Clearance between shift fork and shifter groove	Factory spec.	0.1 to 0.7 mm 0.004 to 0.028 in.
	Allowable limit	1.0 mm 0.04 in.

■ NOTE

- When measuring the clearance, be sure to place the shifter collar between the shift fork and shifter.

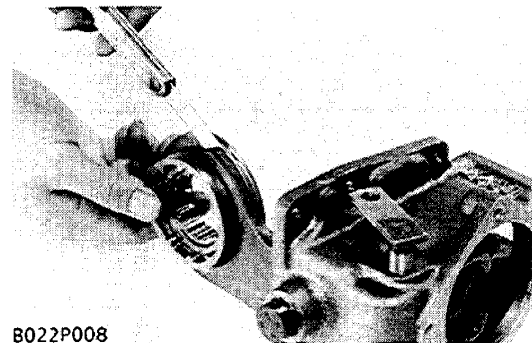

B022P008

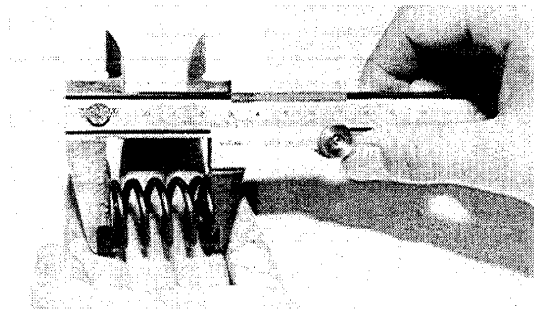

0011P069

Free Length of Bi-speed Turn Spring

1. Measure the free length of the spring with vernier calipers.
2. If the measurement is less than the allowable limit, replace it.

Free length of bi-speed turn spring (short)	Factory spec.	32.5 to 32.6 mm 1.280 to 1.283 in.
	Allowable limit	28.5 mm, 1.22 in.

Free length of bi-speed turn spring (long)	Factory spec.	52.0 mm 2.047 in.
	Allowable limit	45.5 mm 1.791 in.

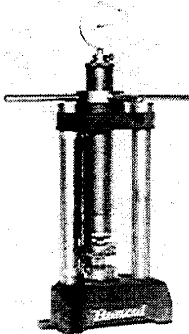

0011P071

Working Load of Bi-speed Turn Spring

1. Put the spring on the spring tester and compress it to the specified length.
2. Read the compression load on the gauge.
3. If the measurement is less than the allowable limit, replace it.

Working load of bi-speed turn spring (short)	Factory spec.	Load 1613 N/Setting length 25.5 mm 164.5 kgf/25.5 mm 362.7 lbs/1.00 in.
	Allowable limit	Load 1411 N/Setting length 25.5 mm 143.9 kgf/25.5 mm 317.4 lbs/1.00 in.

Working load of bi-speed turn spring (long)	Factory spec.	Load 86.3 N/Setting length 35.0 mm 8.8 kgf/35.0 mm 19.4 lbs/1.378 in.
	Allowable limit	Load 75.5 N/Setting length 35.0 mm 7.7 kgf/35.0 mm 17.0 lbs/1.378 in.

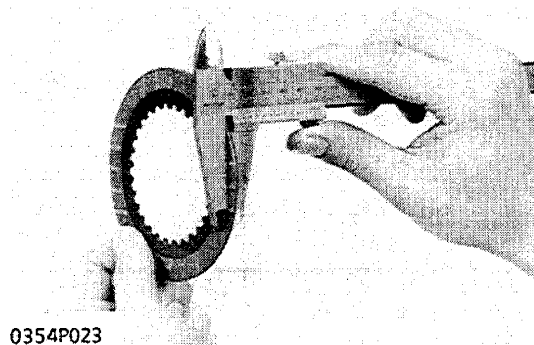

0354P023

Clutch Disc Wear and Friction Plate Wear

1. Measure the thickness of the clutch disc and friction plate (steel plate) with vernier calipers.
2. If the thickness is less than the allowable limit, replace it.

Thickness of clutch disc	Factory spec.	1.7 to 1.9 mm 0.067 to 0.075 in.
	Allowable limit	1.4 mm 0.055 in.

Thickness of friction plate	Factory spec.	0.95 to 1.05 mm 0.037 to 0.075 in.
	Allowable limit	0.8 mm 0.0315 in.

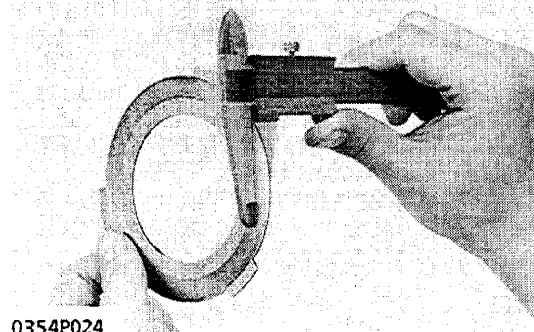

0354P024

(When reassembling)

- After keeping clutch discs in transmission oil for several seconds and apply transmission oil to friction plate, reassembling them in order.

I.1 MOWER
RC54-BB+RC60-B
RC60-21B+RC72-B

CONTENTS

GENERAL	I.1-1
[1] SPECIFICATIONS	I.1-1
[2] EXTERIOR VIEW AND APPELLATION	I.1-2
MECHANISM	I.1-3
[1] POWER TRANSMISSION	I.1-3
[2] LIFTING MECHANISM	I.1-4
SERVICING	I.1-5
TROUBLESHOOTING	I.1-5
SERVICING SPECIFICATIONS	I.1-5
TIGHTENING TORQUES	I.1-5
CUTTING HEIGHT	I.1-6
MAINTENANCE	I.1-6
[1] LUBRICANTS	I.1-6
[2] MAINTENANCE CHECK LIST	I.1-7
[3] CHECK AND MAINTENANCE	I.1-7
[4] ADJUSTING	I.1-9
DISMOUNTING MOWER	I.1-10
SETTING UP	I.1-12
CHECKING, DISASSEMBLING AND SERVICING	I.1-18
CHECKING AND ADJUSTING	I.1-18
DISASSEMBLING AND ASSEMBLING	I.1-18

GENERAL

[1] SPECIFICATIONS

Model of Mower		RC54-B	RC60-B	RC60-21B	RC72-B
Suitable Tractor		B1550, B1750 B1550HST, B1750HST		B2150, B2150HST	
Mounting method		Parallel linkage			
Adjustment of cutting height		Gauge wheel			
Cutting width		1372 mm (54 in.)	1524 mm (60 in.)		1828 mm (72 in.)
Cutting height		38 to 114 mm (1.5 to 4.0 in.)			
Weight (Approx.)		148 kg (327 lbs)	168 kg (371 lbs)		214 kg (472 lbs)
Deck thickness		3.3 mm (0.13 in.)	3.6 mm (0.14 in.)		
Blade spindle speed		52.9 r/s (3171 rpm)	47.9 r/s (2875 rpm)	47.4 r/s (2841 rpm)	41.8 r/s (2507 rpm)
Blade tip velocity		78.7 m/s (15500 fpm)		77.7 m/s (15300 fpm)	82.3 m/s (16200 fpm)
Blade length		475 mm (18.7 in.)	523 mm (20.6 in.)		625 mm (24.6 in.)
Number of blades		3			
Dimensions	Total length	1008 mm (39.7 in.)	1060 mm (41.7 in.)		1282 mm (50.5 in.)
	Total width	1758 mm (69.2 in.)	1881 mm (74 in.)		2237 mm (88.1 in.)
	Total height	345 mm (13.6 in.)	345 mm (13.6 in.)		430 mm (16.9 in.)

[2] EXTERIOR VIEW AND APPELLATION

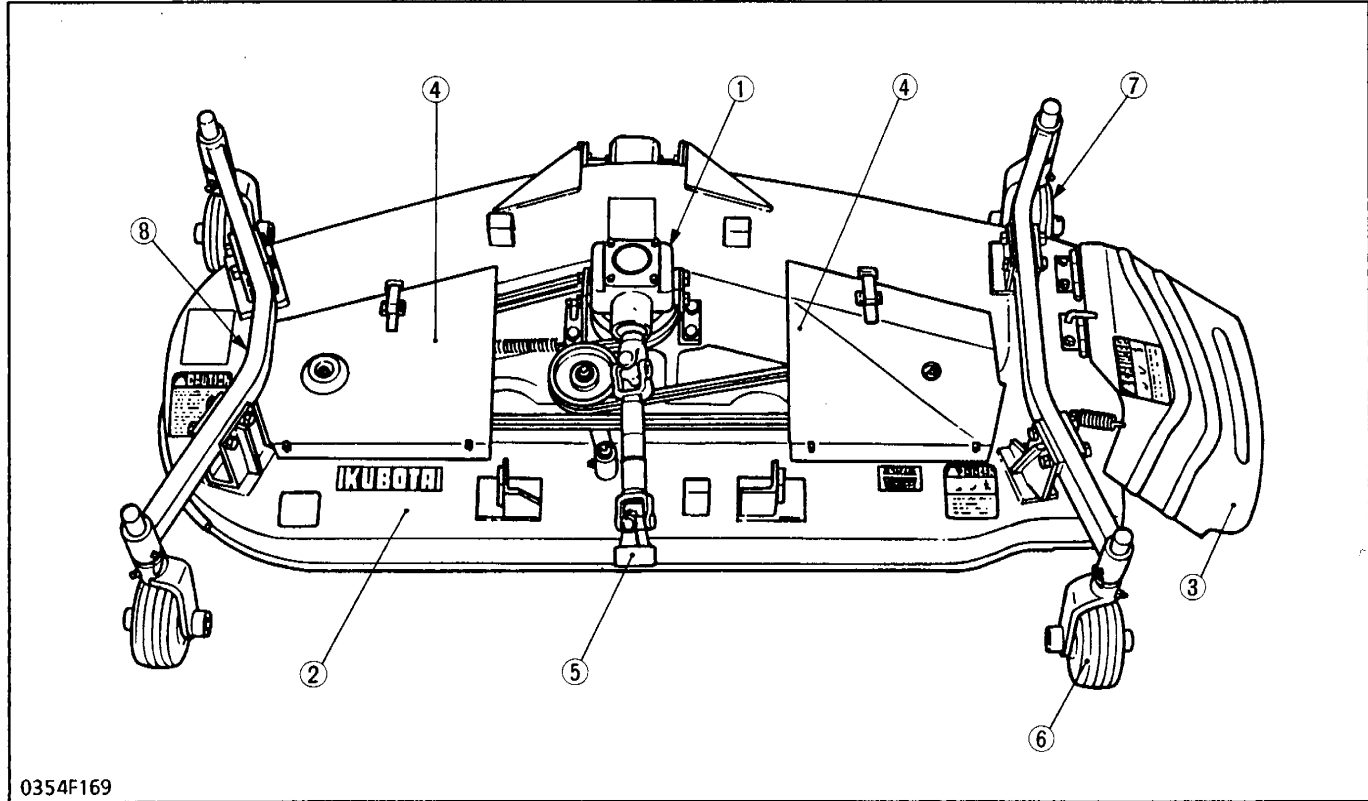

- | | | | |
|--------------|-------------------------|----------------------|-----------------------|
| (1) Gear Box | (3) Discharge Deflector | (5) Universal Joint | (7) Front Gauge Wheel |
| (2) Deck | (4) Shield | (6) Rear Gauge Wheel | (8) Gauge Wheel Stay |

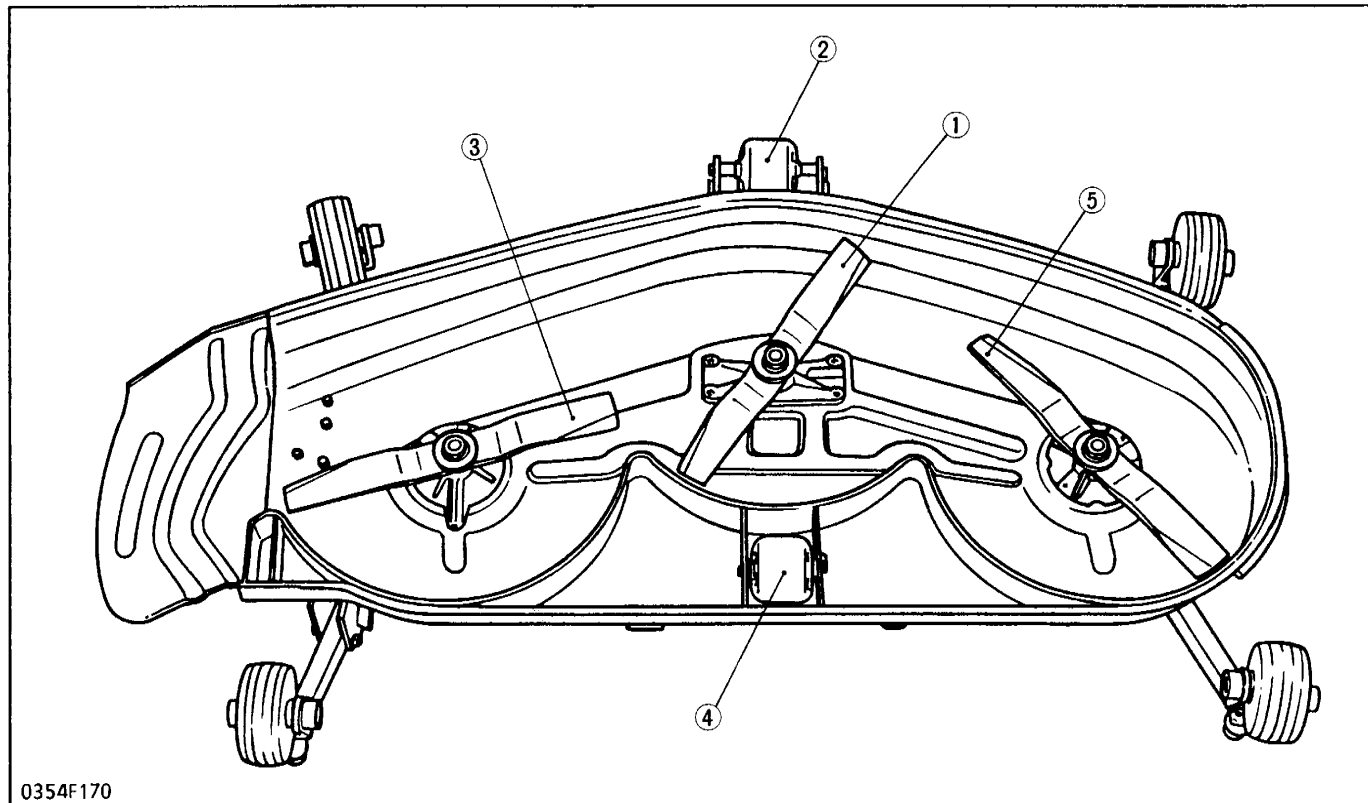

- | | | | |
|-----------------------------|-----------------|----------------------------|-----------------|
| (1) Center Blade | (3) Outer Blade | (4) Rear Anti-scalp Roller | (5) Outer Blade |
| (2) Front Anti-scalp Roller | | | |

MECHANISM

[1] POWER TRANSMISSION

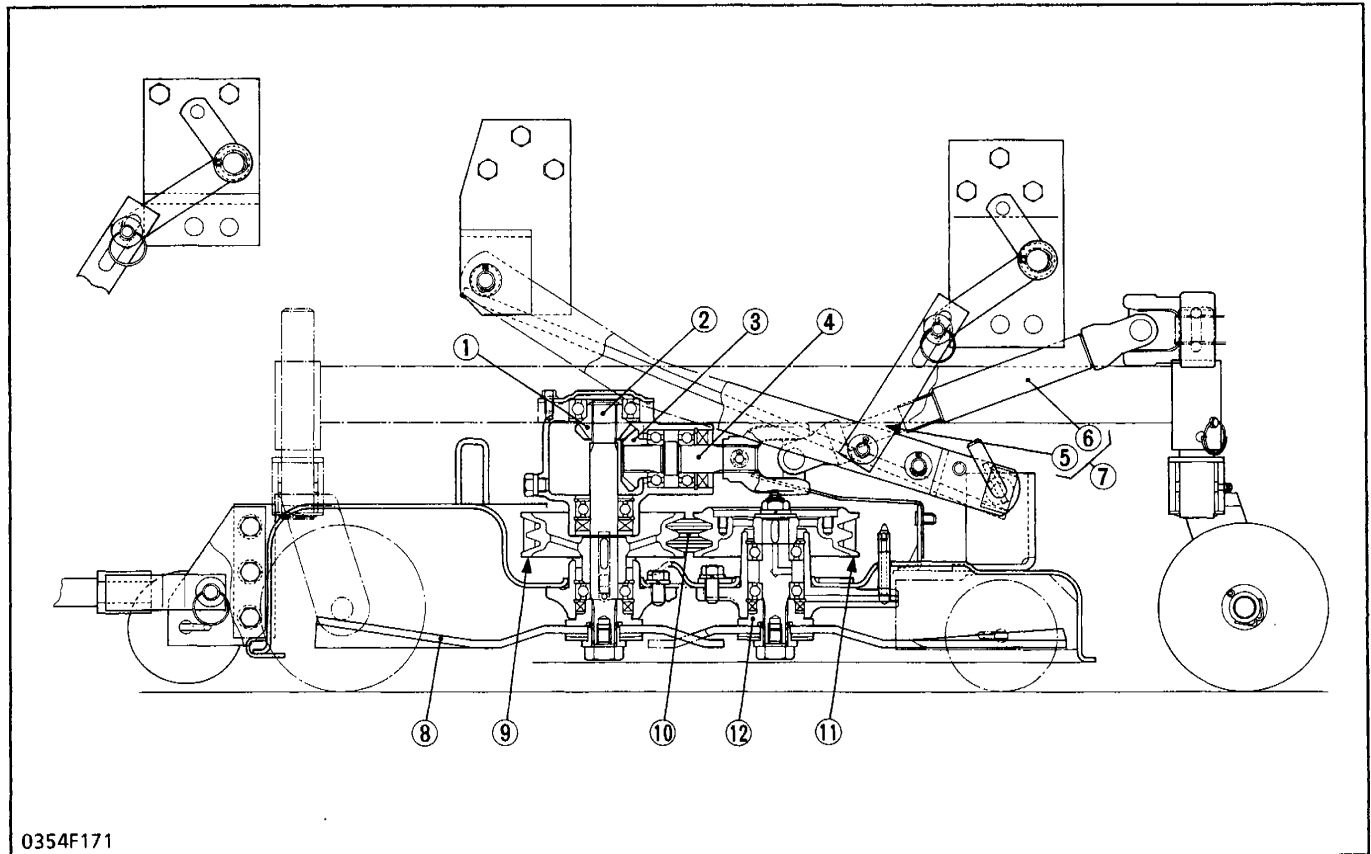

0354F171

- | | | | |
|--------------------|------------------|---------------------|-------------------|
| (1) 15T Bevel Gear | (4) Pinion Shaft | (7) Universal Joint | (10) V-belt |
| (2) Spindle Shaft | (5) Shaft Yoke | (8) Blade | (11) Side Pulley |
| (3) 22T Bevel Gear | (6) Spline Yoke | (9) Center Pulley | (12) Cutter Shaft |

The power is transmitted from mid PTO to blades (8) as follows:

Mid PTO → Universal Joint (7) → Pinion Shaft (4)
 → 22T Bevel Gear (3) → 15T Bevel Gear (1) → Bevel
 Gear Shaft (2) → Center Pulley (9) → V-belt (10) →
 Side Pulley (11)

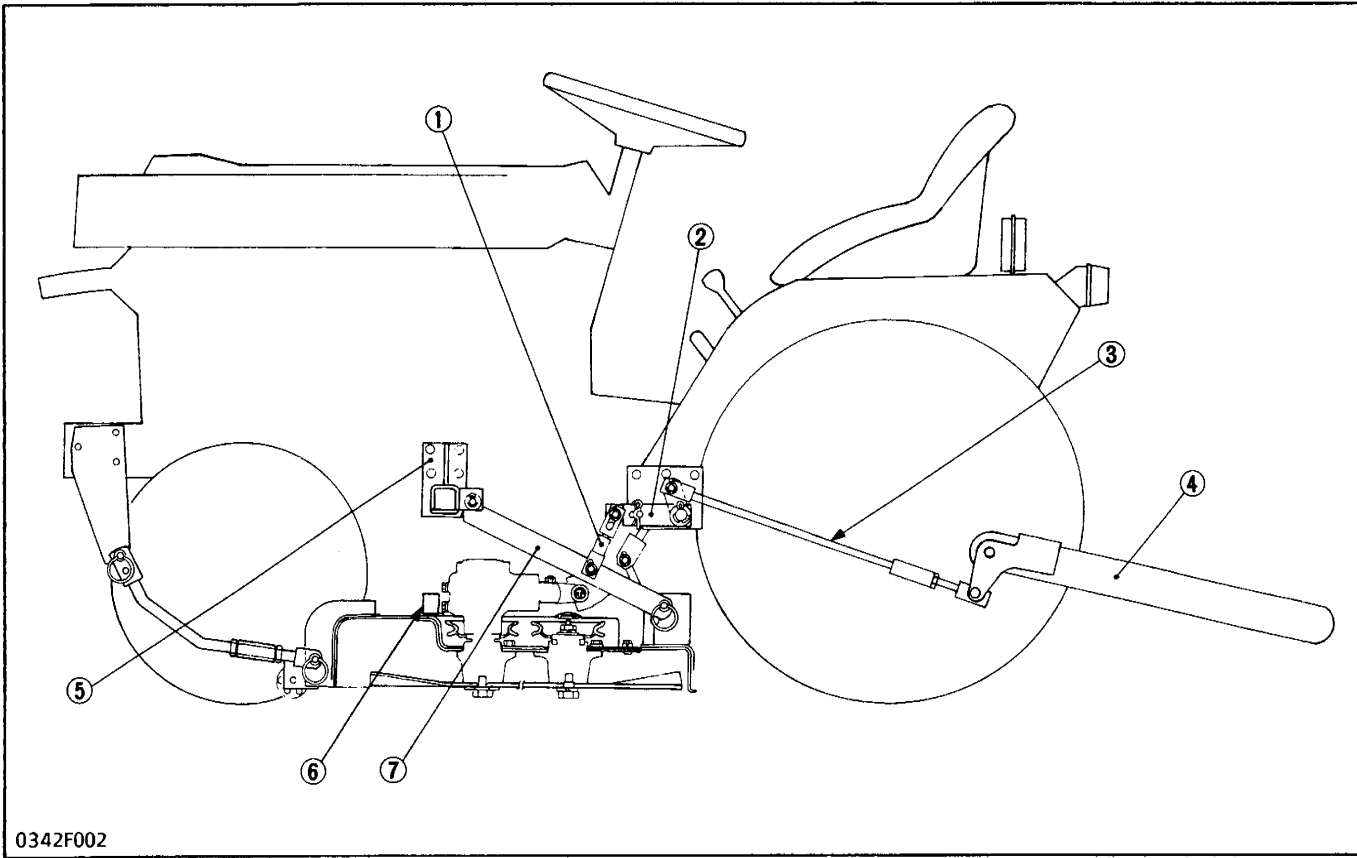
[2] LIFTING MECHANISM

0342F002

(1) Lift Rod
(2) Lift Link

(3) Connecting Rod
(4) Lower Link

(5) Hanger or Stop Bracket
(6) Stopper

(7) Link

The lifting of mower is performed by the hydraulic system installed on the tractor. (Refer to M.8 "HYDRAULIC SYSTEM")

For avoiding danger, the mower should be kept lifting when travelling. When the control lever is moved to the LIFT position, the lower link (4) is risen by the oil pressure of hydraulic system, and the connecting rod (3) is pulled rearward.

Then lift link (2) rounds and the link (7) is raised upward so that the dimension "L" (between the hanger bracket and stopper) is 2 to 5 mm (0.08 to 0.20 in.). Therefore, the mower is lifted.

As the upper link system is a pantographic linkage, the mower can be kept parallel at every position.

⚠ CAUTION

- Never operate mower in transport position.

SERVICING

TROUBLESHOOTING

Symptom	Probable Cause	Solution	Reference Page
Blade Does Not Turn	<ul style="list-style-type: none"> Broken belt 	Replace	I.1-18
Blade Speed Is Slow	<ul style="list-style-type: none"> Loosen belt Clogged grass Flattened out or worn cup washer 	Adjust tension properly or Replace Remove Replace	I.1-18 I.1-18,19 I.1-19
Cutting Is Poor	<ul style="list-style-type: none"> Worn and broken blade 	Sharpen blade or Replace	I.1-18,19
Mower Is Not Lifted	<ul style="list-style-type: none"> Broken rod or link Trouble of hydraulic system 	Replace Check hydraulic system	- S.8 (HYDRAULIC SYSTEM)

SERVICING SPECIFICATIONS

Item		Model	Factory Specification
Bevel Gear	Backlash	All	0.10 to 0.20 mm 0.0039 to 0.0079 in.
Front Link	Length	RC54-B, RC60-B	505 mm, 19.9 in.
		RC60-21B, RC72-B	535 mm, 21.0 in.
Connecting Rod	Length	RC54-B, RC60-B	640 mm, 25.2 in.
		RC60-21B, RC72-B	710 mm, 28.0 in.
Lift Link	Length	for B1550-B1750	Left: 60 mm, 2.4 in. Right: 82 mm, 3.2 in.
		for B1550HST-B1750HST	Left: 60 mm, 2.4 in. Right: 100 mm, 3.9 in.

TIGHTENING TORQUES

Tightening torques of screws and nuts on the table below are especially specified.
(For general use screws and nuts: See page S.G-4)

Item	N·m	kgf·m	ft-lbs
Blade Screw (Center, Outer)	98 to 118	10 to 12	72 to 87
Gear Box Bracket Mounting Screw	77.5 to 90.2	7.9 to 9.2	57.1 to 66.5
Outer Pulley Mounting Nut	196 to 226	20 to 23	142 to 167
Pulley Holder Mounting Screw	77.5 to 90.2	7.9 to 9.2	57.1 to 66.5

CUTTING HEIGHT

	RC54-B RC60-B, RC60-21B	RC72-B	
CUTTING HEIGHT			
		0354F221	
	WHEEL	FRONT WHEEL	REAR WHEEL
38 mm (1½ in.)	C-X	D-X	D-Y
51 mm (2 in.)	C-Y	D-Y	C-X
64 mm (2½ in.)	B-X	C-X	C-Y
76 mm (3 in.)	B-Y	C-Y	B-X
89 mm (3½ in.)	A-X	B-X	B-Y
102 mm (4 in.)	A-Y	B-Y	A-X
114 mm (4½ in.)	—	A-X	A-Y

■ **NOTE**

- Adjust four wheels according to desired mowing height. Refer to the chart left.
- Use the 1st mid PTO speed if your tractor is B1550 or B1750. And use the 2nd mid PTO speed if your tractor is B2150.

MAINTENANCE

[1] LUBRICANTS

Place	Model	Capacity	Lubricants
Gear Box	RC-54B RC60-B RC60-21B	0.4 ℓ, 0.42 U.S. qts., 0.352 Imp. qts.	SAE 90 gear oil
	RC72-B	0.75 ℓ, 0.79 U.S. qts., 0.660 Imp. qts.	
Front and Rear Gauge Wheel	All	Until grease overflows (2 spots)	Multipurpose type grease
Spindle Shaft (Three)	All	Until grease overflows (3 spots)	
Universal Joint (Grease nipples)	All	Until grease overflows (2 spots)	
(Internal Splines)	All	Sufficiently	
Belt Tension Pivot and Tension Pulley	All	Until grease overflows (2 spots)	

[2] MAINTENANCE CHECK LIST

NO	Check Point	Used hours (Change or check every interval shown below)											After purchase 2 year	Reference page	
		daily check	50	100	150	200	250	300	350	400	450	500			
1	Anything unusual in previous day's operation	O													-
2	Oil leakage check	O													I.1-7
3	Make sure blade capscrews are tight.	O													-
4	Blade wear check	O													I.1-18
5	All hardware check	O													-
6	Make sure all pins are in place.	O													-
7	Mower deck cleaning	O													-
8	Gear box oil change			●				●				●			I.1-7
9	Gear box oil check		O												I.1-7
10	Greasing ● Universal joint ● Front and rear gauge wheels ● Three spindle shafts ● Belt tension pulley ● Belt tension pivot		O	O	O	O	O	O	O	O	O	O	O		I.1-7, 8
11	Gear box oil seal change												O		I.1-7, 21

Note: The jobs indicated by ● must be done at 50 and 100 hours respectively.

[3] CHECK AND MAINTENANCE

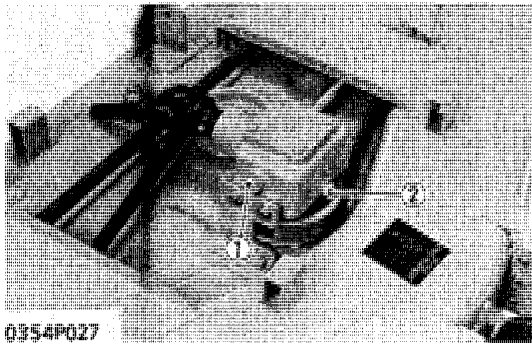

0354P027

(1) Check Plug

(2) Drain Plug

Checking Oil Level in Gear Box

- Place the mower on level ground and loosen the check plug (1).
- Check to see if oil seep from the opening.
- If the oil level is below, add sufficient SAE 90 gear oil.

Gear box oil	RC54-B RC60-B RC60-21B	0.40 ℓ 0.42 U.S. qts. 0.352 Imp. qts.
	RC72-B	0.75 ℓ 0.79 U.S. qts. 0.660 Imp. qts.

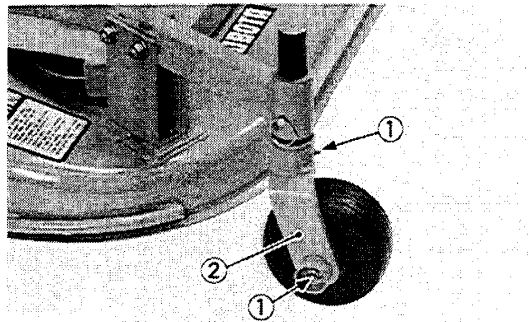

0354P028

(1) Grease Nipple

(2) Gauge Wheel Bracket

Greasing Wheels

- Grease the grease nipple (1) of front and rear gauge wheel, if the amount of grease is insufficient.

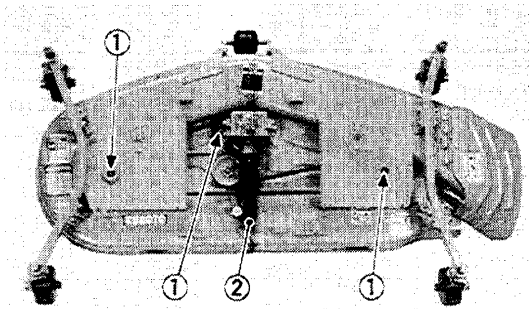

0354P029

Greasing Three Spindle Shafts

1. Grease the grease nipples (1) of the spindle shafts if the amount of grease is insufficient.

- (1) Grease Nipple
- (2) Spline

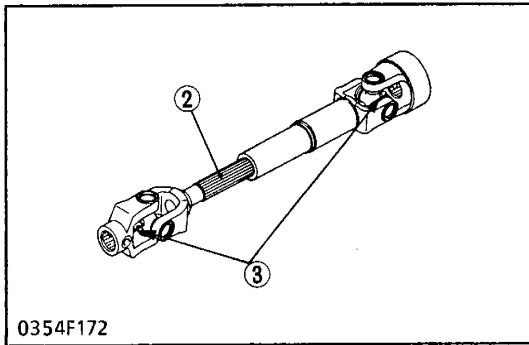

0354F172

Greasing Internal Splines and Grease Nipples of Universal Joint

1. Grease the internal splines (2) and grease nipples (3) of the universal joint if the amount of grease is insufficient.

- (2) Spline
- (3) Grease Nipple

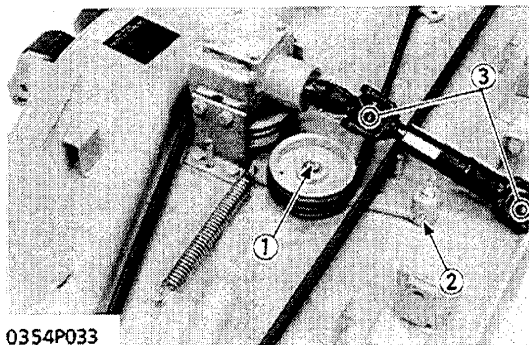

0354P033

Greasing Belt Tension Pivot and Tension Pulley

1. Grease the grease nipples (1), (2) of the belt tension pivot and tension pulley.

NOTE

- Use SAE 90 gear oil in all seasons.
- Change oil in gear box after first 50 hrs. and every 150 hrs. there after.
- After checking above items, replace any worn, damaged or missing parts.
- Dry deck completely before storage, or pulley belt damage can result.

- (1) Grease Nipple (Belt Tension Pulley)
- (2) Grease Nipple (Belt Tension Pivot)
- (3) Grease Nipple (Universal Joint)

[4] ADJUSTING

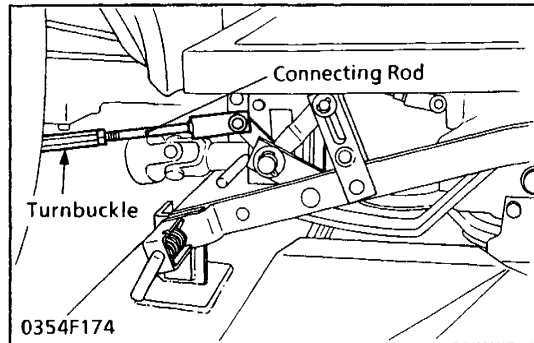
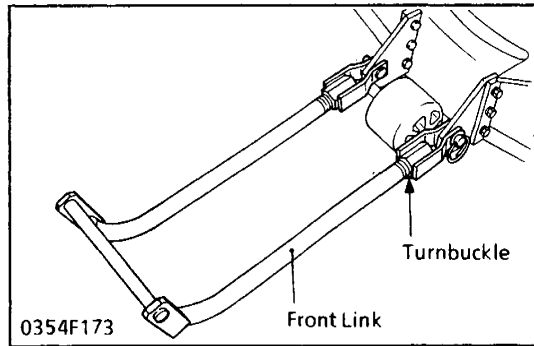

[B1550-B1750]

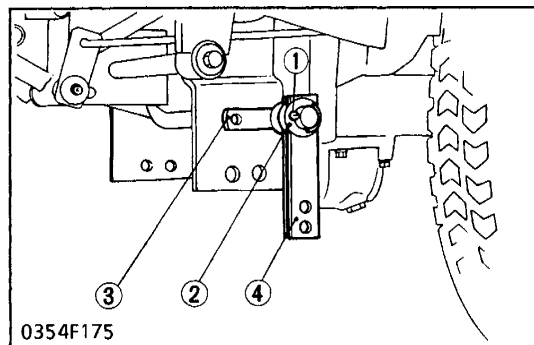

Adjusting Connecting Rods, and Parallel Linkage

1. Park the tractor on level ground with the mower touching the ground.
2. Adjust the height of the four mower gauge wheels the same.
3. If the front wheels are not on the ground, remove the front link to the mower. And adjust the front link turnbuckle until the wheels come into contact with the ground.
4. Attach the front link to the mower.
5. Start the engine.
6. Raise the tractor lower links to the maximum lifting position and shut off the engine.
7. Adjust the turnbuckles of the left and right connecting rods so that the dimension (L) is 2 to 5 mm (0.08 to 0.20 in.)

Dimension "L"	Factory spec.	All	2 to 5 mm 0.08 to 0.20 in.
Front link length	Factory spec.	RC54-B, RC60-B	505 mm, 19.9 in.
		RC60-21B, RC72-B	535 mm, 21.0 in.
Connecting rod length	Factory spec.	RC54-B, RC60-B	640 mm, 25.2 in.
		RC60-21B, RC72-B	710 mm, 28.0 in.
Lift link length	Factory spec.	RC54-B, RC60-B for B1550.B1750	(Right): 82 mm, 3.2 in. (Left): 60mm, 2.4 in.
		RC54-B, RC60-B for B1550HST B1750HST	(Right): 100 mm, 3.9 in. (Left): 60mm, 2.4 in.

NOTE

- Usually no need to adjust the length of stop bolt and front link. But when the parts is removed, adjust them according to following valve.
- Proper adjustment for the mower connecting rod length is very important to avoid damage to the lift frame.

- (1) Cotter Pin
(2) Plain Washer

- (3) Lift Link (LH)
(4) Stop Link

[B1550, B1750]

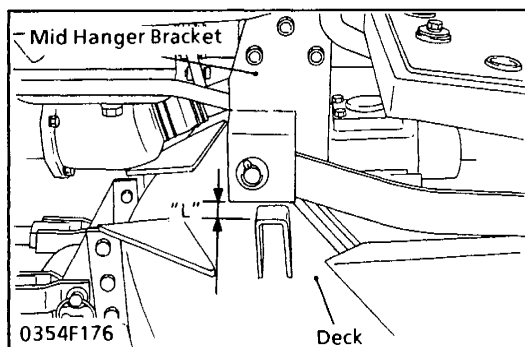

[B1550, B1750 + RC54-B or RC60-B + B1640A]

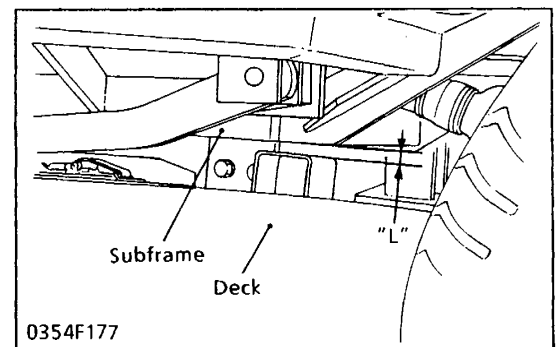

[B2150]

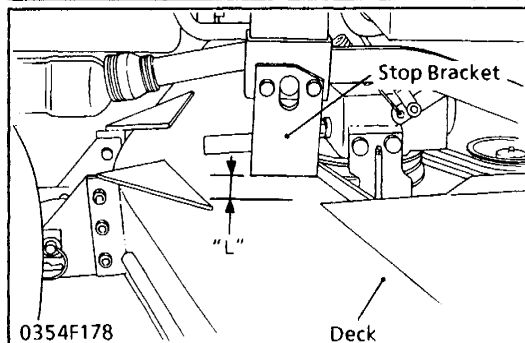

[B2150 + RC60-21B or RC72-B + BF350A]

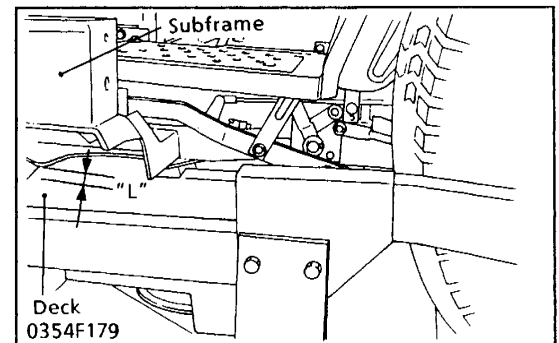

DISMOUNTING MOWER

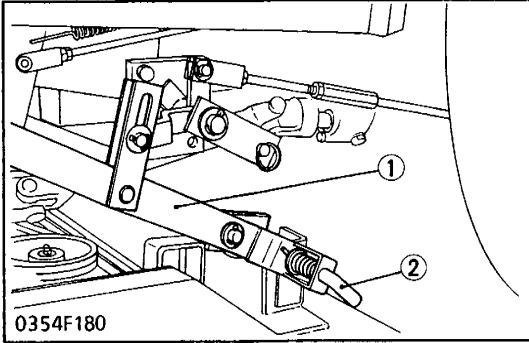

Link

1. Push down the tractor's hydraulic control lever to lower the mower link.
2. Disconnect the mower's rear links (1), pulling the L-pin (2).
3. Start the engine and shift the control lever to the LIFT position.

■ IMPORTANT

- When starting the engine PTO lever must be set to NEUTRAL.

(1) Rear Link

(2) L Pin

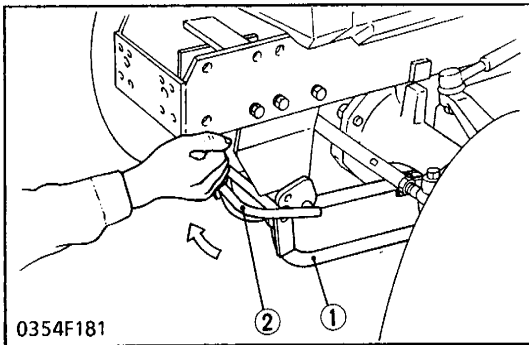

Front Link

1. Push down the link fixing lever (2), pulling the lever fulcrum fixing pin.

(1) Front Link

(2) Link Fixing Lever



Universal Joint

■ NOTE

- The shaft has a master spline to prevent incorrect alignment.

(When reassembling)

- Spread the cotter pin completely.

Taking Out Mower

1. Remove the mower referring to the left chart.

	B1550		B1750		B2150	
	2WD	4WD	2WD	4WD	2WD	4WD
RC54-B					—	—
RC60-B					—	—
RC60-21B	—	—	—	—		
RC72-B	—	—	—	—		

: Drive over forward for removing

: Drive over rearward for removing

: Lateral removing

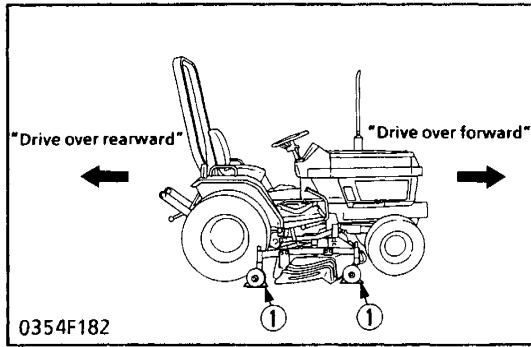

NOTE

[Drive over forward or rearward for removing]

- (1) Chock

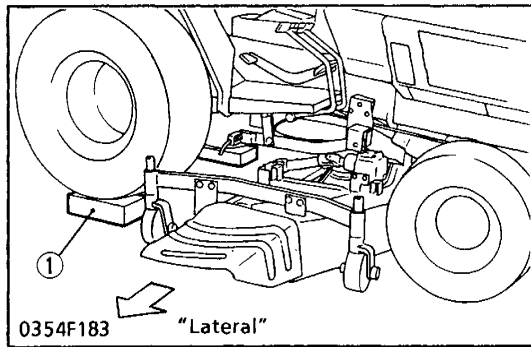

[Lateral removing]

- For lateral removal, run the tractor so that the rear wheels should come on 50 to 100 mm (2 to 4 in.) high blocks.

- (1) Block

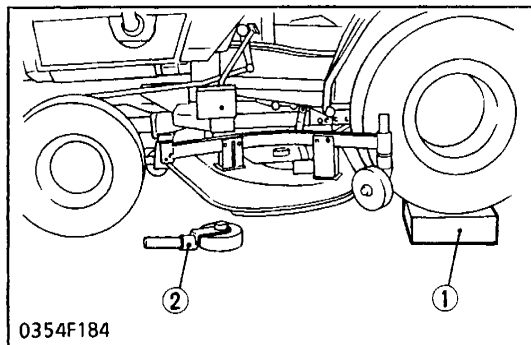

[Taking out the mower from the tractor with Front Loader]

- Remove the left-hand front gauge wheel when taking the mower from the tractor with front loader.

- (1) Block

- (2) Left Side Front Gauge Wheel

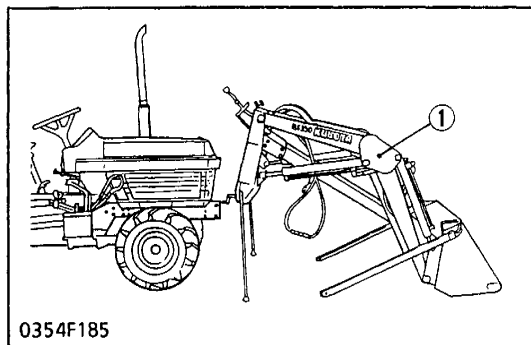

[Mounting the mower to the tractor with Front Loader]

- Remove the front loader from the tractor as illustrated left.
- Mount the mower by lateral matching.

- (1) Front Loader

SETTING UP (before mounting the mower)

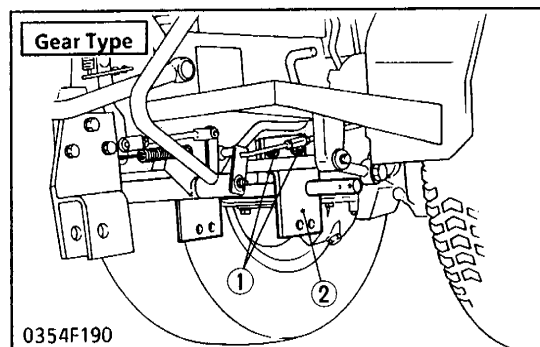
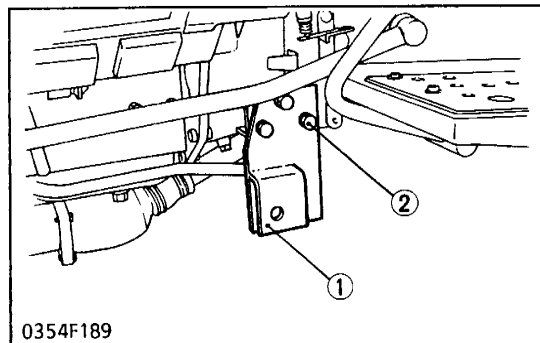
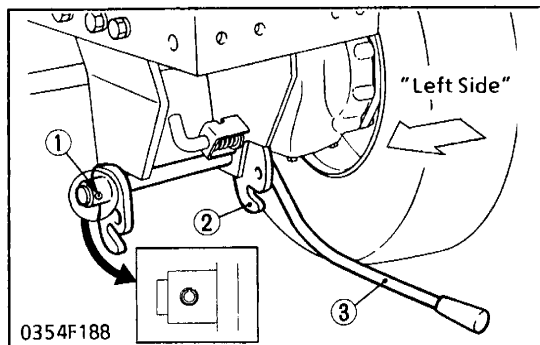
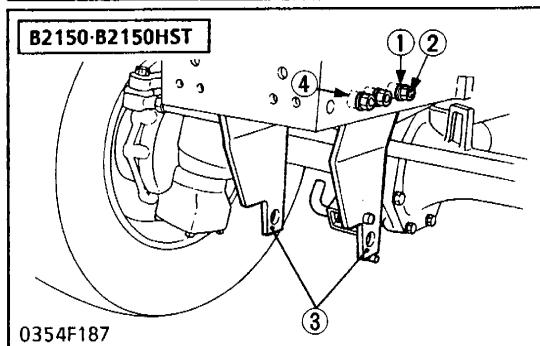
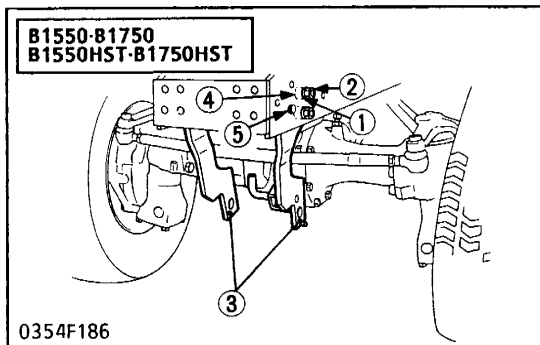

Mounting the Front Hanger Brackets to the Tractor

1. Attach the front hanger brackets to the tractor with M12 bolts, spring washers and nuts.

- | | |
|--------------------------|-------------------------------|
| (1) Spring Washer | (4) Bolt (M12 x length 35 mm) |
| (2) Nut | (5) Bolt (M12 x length 45 mm) |
| (3) Front Hanger Bracket | |

2. Insert the link fixing lever from the left of the stay and mount the link fulcrum in position with the spring pin at the right of the stay.

- | | |
|------------------|-----------------------|
| (1) Spring Pin | (3) Link Fixing Lever |
| (2) Link Fulcrum | |

Mounting the Mid and Rear Hanger Brackets to the Tractor

[B1550-B1750]

1. Attach the mid hanger brackets to the tractor with M10 bolts.

- | | |
|------------------------|-------------------------------|
| (1) Mid Hanger Bracket | (2) Bolt (M10 x length 30 mm) |
|------------------------|-------------------------------|

2. Attach the rear hanger brackets to the tractor with M10 bolts.

- | | |
|-------------------------------|-------------------------|
| (1) Bolt (M10 x length 30 mm) | (2) Rear Hanger Bracket |
|-------------------------------|-------------------------|

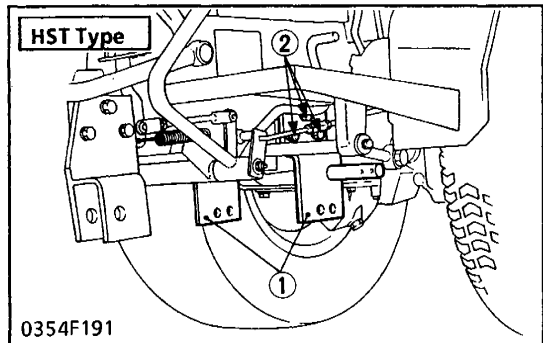

(1) Rear Hanger Bracket

(2) Bolt (M10 x length 30 mm)

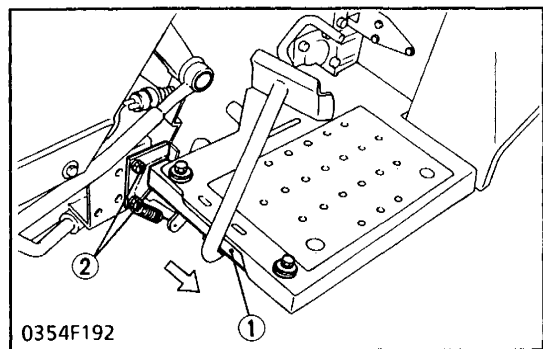

[B2150]

1. Remove the bolts and slide the step brackets out.

(1) Step Bracket

(2) Bolt (M10)

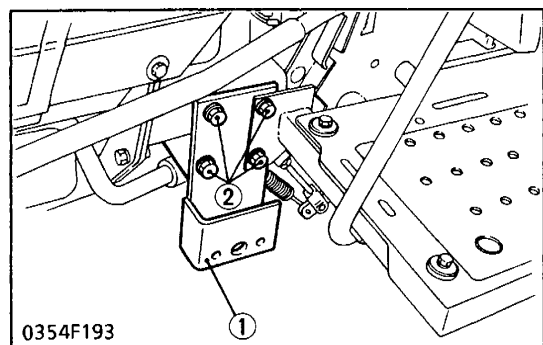

2. Attach the mid hanger brackets to the tractor with M10 bolts.

(1) Mid Hanger Bracket

(2) Bolt (M10 x length 30 mm)

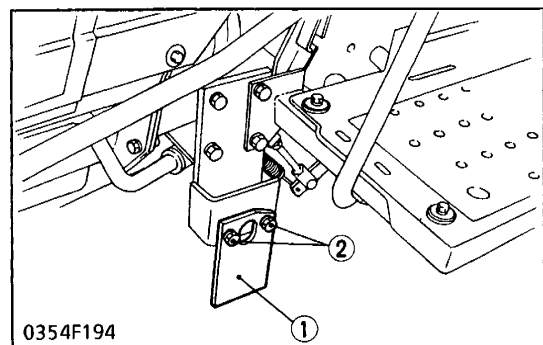

3. Attach the stop brackets to the mid hanger brackets with M10 bolts.

(1) Stop Bracket

(2) Bolt (M10 x length 22 mm)

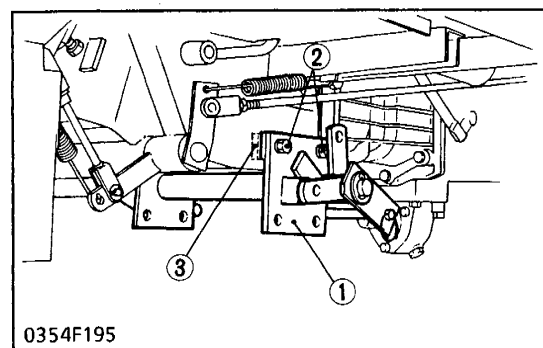

4. Attach the rear hanger brackets to the tractor with M10 bolts.

NOTE

- When attaching the rear hanger brackets to the tractor, use the spacers as illustrated. For HST models, the spacers are not needed.

Bolt(D) = 4-M10X50 (B2150 2WD, 4WD)

Bolt(D) = 4-M10X35 (B2150 HST 2WD, 4WD)

(1) Rear Hanger Bracket

(3) Spacer

(2) Bolt (M10)

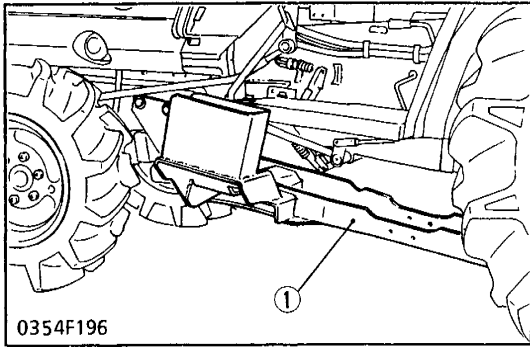

0354F196

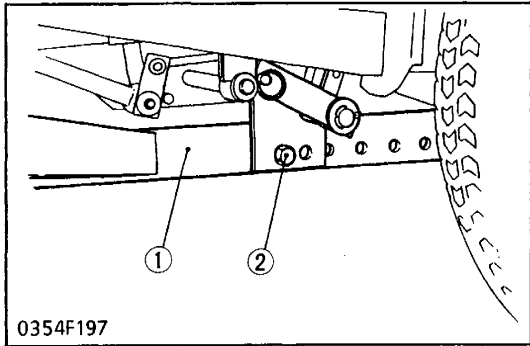

0354F197

**Mounting Hanger Brackets to Tractor with Front Loader
(B1640A)**

1. Install the subframe to the tractor as illustrated left.

(1) Loader Sub Frame

2. Install the mid rear hanger brackets to the tractor. Refer to I.1-12, 13.

3. Install the subframe to the tractor securely. (Refer to loader OPERATOR'S MANUAL.)

4. Install the lift link to the subframe with M10 bolts, spring washers, plain washer and nuts.

(1) Subframe

(2) Bolt (M10 x Pitch 30 mm)

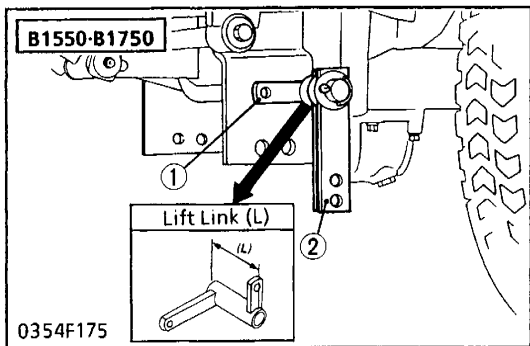

0354F175

Setting Up the Links

1. Attach the lift links and stop links to the mid hanger brackets with plain washers and cotter pins.

Tractor	Type	LIFT LINK (L)	
		Right side	Left side
B1550 B1750	Gear	82 mm (3.2 in.)	60 mm (2.4 in.)
	HST	100 mm (3.9 in.)	

(1) Lift Link (LH)

(2) Stop Link

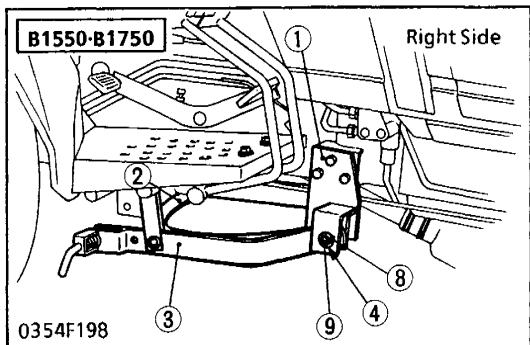

0354F198

2. Attach the parallel links and anti-sway link to the mid hanger brackets with clevis pins, plain washers and cotter pins.

3. Attach the link 1 to the lift links with clevis pins and 2 plain washers.

4. Attach the stop links to the link 1 with snap rings and plain washers (Only for B1550, B1750).

5. Attach the anti-sway link to the parallel links with clevis pins, plain washers and cotter pins.

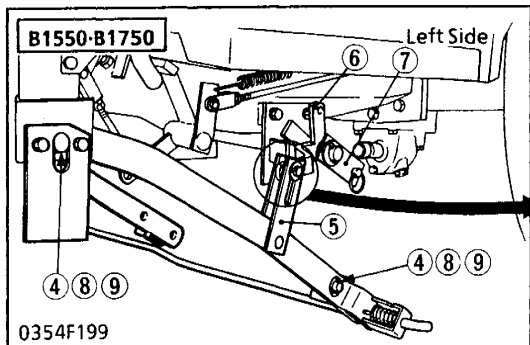

0354F199

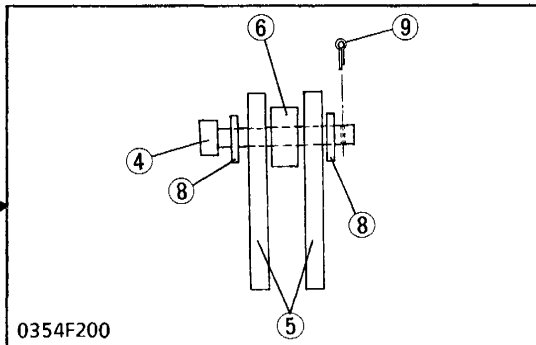

0354F200

- (1) Mid Hanger Bracket
- (2) Anti-sway Link
- (3) Parallel Link
- (4) Clevis Pin
- (5) Link 1
- (6) Lift Link
- (7) Stop Link
- (8) Plain Washer
- (9) Cotter Pin

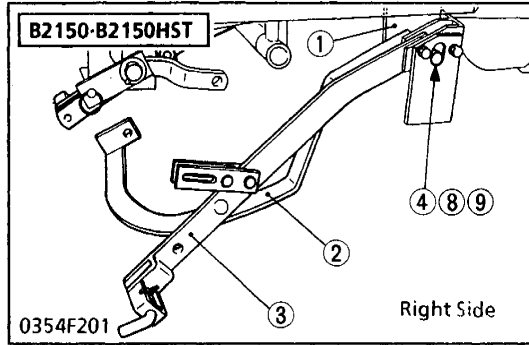

- (1) Mid Hanger Bracket
- (2) Anti-sway Link
- (3) Parallel Link
- (4) Clevis Pin
- (5) Link 1
- (6) Lift Link
- (7) Stop Link
- (8) Plain Washer
- (9) Cotter Pin
- (10) Snap Ring

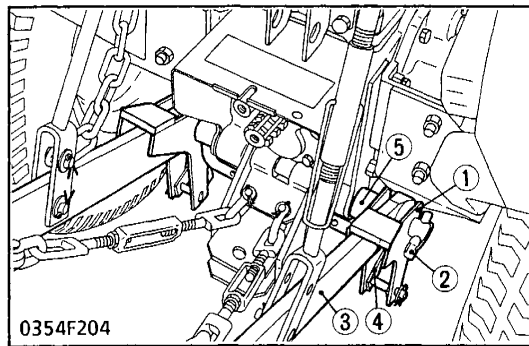
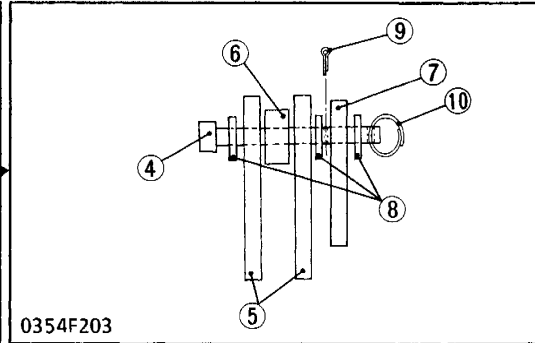
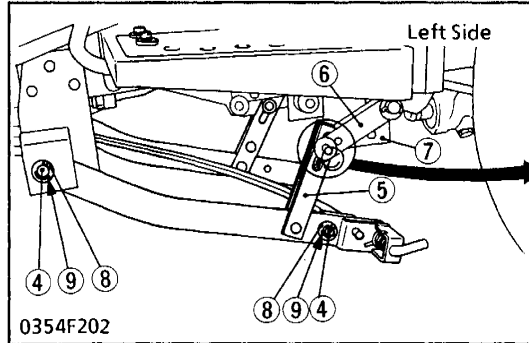

6. Attach the lift brackets.

[B1550-B1750]

- Remove lower links from the tractor.
- Attach both check chain brackets, the lift brackets and lower links to the lower link pins as illustrated.

- (1) Lift Bracket
- (2) Lower Link Pin
- (3) Lower Link
- (4) Connecting Rod
- (5) Check Chain Bracket

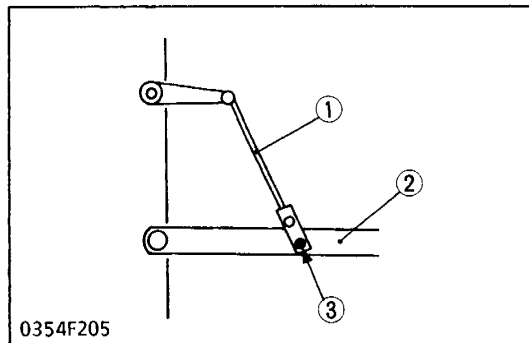

- Connect lift rods to the lower links and adjust the length of both lift rods equally with the turnbuckle of the right lift rod.

- (1) Lift Rods
- (2) Lower Link
- (3) Setting Position

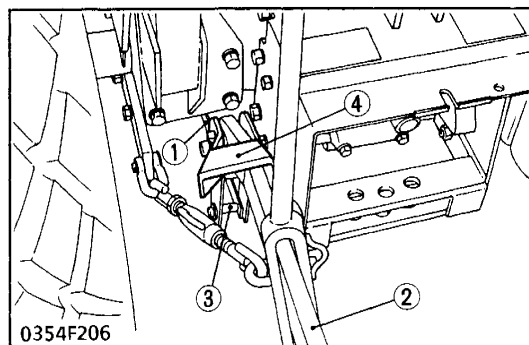

[B2150]

- Remove lower links from the tractor.
- Attach the lift brackets and lower links to the lower link pins as illustrated.

- (1) Lift Rod
- (2) Lower Link (LH)
- (3) Lower Link Pin
- (4) Lift Bracket

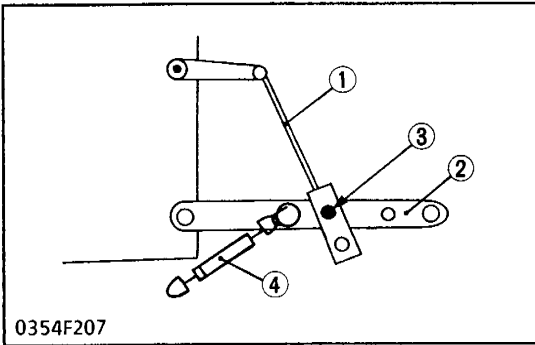

- Connect lift rods to the lower links and adjust the length of both lift rods equally with the turnbuckle of the right lift rod.

- (1) Lift Rod
- (2) Lower Link
- (3) Setting Position
- (4) Check Chain

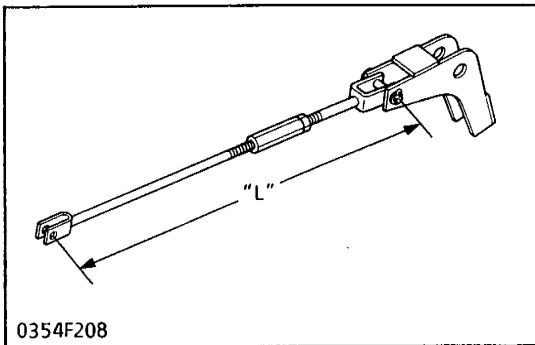

■ NOTE

- Make sure the length (L) of the mower connecting rod is as shown in the chart below.

MOWER	CONNECTING ROD (L)
RC54-B RC60-B	640 mm (25.2 in.)
RC60-21B RC72-B	710 mm (28 in.)

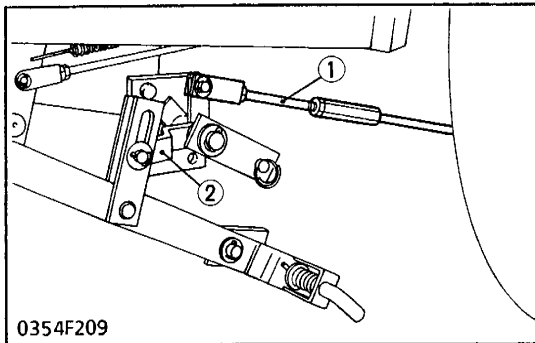

- 7. Connect the connecting rods to the lift links with clevis pins, plain washers and cotter pins.

- (1) Connecting Rod
- (2) Lift Link

Tractor	Tires	Tread
B1550 2WD B1750 2WD	5.00-10	850 mm (33.5 in.)

Mounting Tires to Tractor

■ IMPORTANT

- Adjust tire tread by referring to the figures below. For tires not discussed here, see the operator's manual for the tractor.

- (1) FRONT TIRES (ONLY 2WD tractor with farm tires)
- (2) REAR TIRES (ONLY B1550, B1750 Tractor)

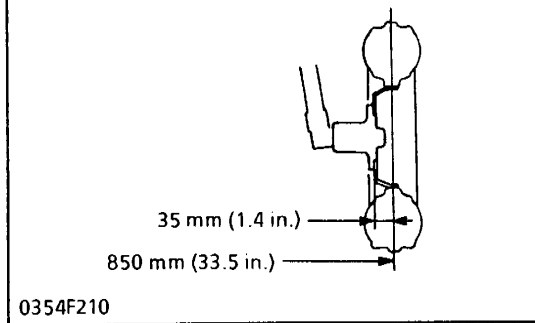

8-16 Farm	9.5-16 Farm	31X13.5-15 Turf
0354F211	0354F212	0354F213

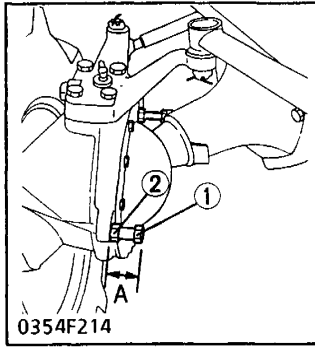

Steering Wheel Angle Adjustment

(4WD tractor with front farm Tires (6-12B) only)
Adjust the length of the adjusting bolts as illustrated.

- B1550 4WD (without Bi-speed turn) + RC54-B or RC60-B

(1) Adjusting Bolt

(2) Lock Nut

Length "A"	Factory spec.	23 mm (0.9 in.)
------------	---------------	-----------------

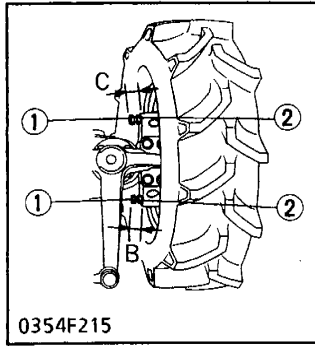

- B1750 4WD (without Bi speed turn) + RC54-B or RC60-B

(1) Adjusting Bolt

(2) Lock Nut

Length "B"	Factory spec.	23 mm (0.9 in.)
Length "C"		31 mm (1.2 in.)

CHECKING, DISASSEMBLING AND SERVICING

CHECKING AND ADJUSTING

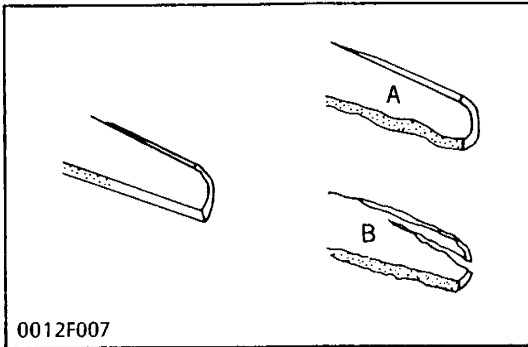

Checking Blade

1. Check the cutting edge of blade.
2. Sharpen the cutting edges, if the blades are as shown in figure A. Replace the blades, if they are as shown in figure B. (Refer to "DISASSEMBLING AND ASSEMBLING")

NOTE

- To sharpen the blades by yourself, clamp the blade securely in a vise and use a large mill file along the original bevel. File to a sharp edge.
- To balance the blade, place a small rod through the center hole and check to see if the blade balances evenly. File heavy side of the blade until it balances out even.

Checking Belt

1. Check to see the belt.
2. Replace the belt with a new one, if there is found surface split at more than 3 positions.

(When replacing belt)

1. Remove the mower from the tractor.
2. Remove the left and right hand shield from the mower deck.
3. Clean around the gear box.
4. Remove the right hand bracket which mounts the gear box to the mower deck.
5. Remove the belt from the tension pulley. Slip the belt over the top of the gear box.
6. To install a new belt, reverse the above procedure.

Tightening torque	Gear box bracket mounting screw	77.5 to 90.2 N·m 7.9 to 9.2 kgf·m 57.1 to 66.5 ft-lbs
-------------------	---------------------------------	---

IMPORTANT

- After setting the gear box bracket mounting screws on the deck without tightening then, mount the other screws on the gear box. And finally tighten them.

(1) Right Hand Gear Box Bracket

(2) Tension Pulley

0012P029

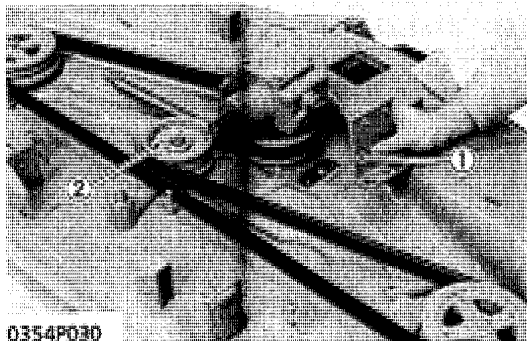

0354P030

DISASSEMBLING AND ASSEMBLING

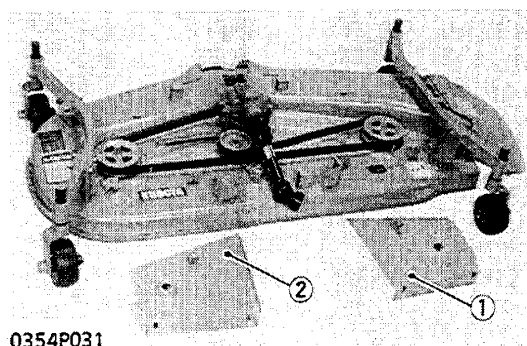

0354P031

Shield

1. Remove the right and left pantograph linkages.
2. Remove the right and left shields.

(When reassembling)

- Spread the cotter pin completely.

(1) R.H. Shield

(2) L.H. Shield

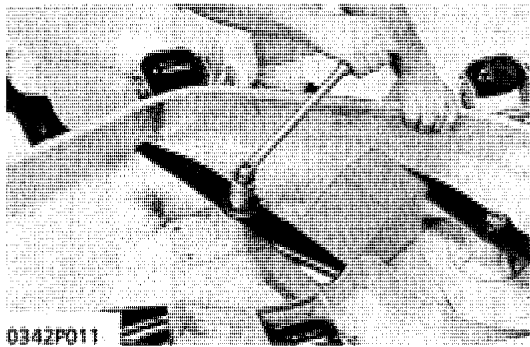

0342P011

Center Blade

1. Turn over the mower.
2. Loosen the blade screw.
3. Remove the blade screw, spline boss, 2-cup washers and blade.

NOTE

- To remove the blade securely, wedge a block of wood between one blade and the housing in such position that it will hold the blade safely while loosening or tightening the blade screw.

(When reassembling)

- Be sure to assemble the friction washer and 2-cup washers between the blade and screw.

IMPORTANT

- Make sure the cup washer is not flattened out or worn, causing blade to slip easily. Replace 2-cup washers and friction washer if either is damaged.

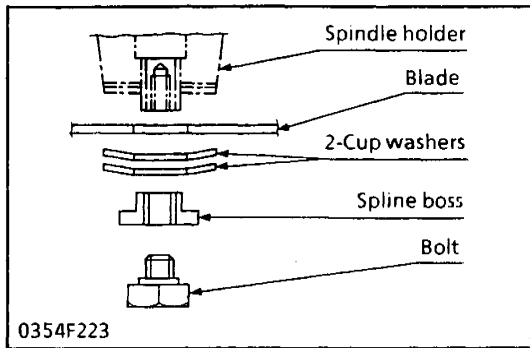

0354F223

Tightening torque	Blade screw	98 to 118 N·m 10 to 12 kgf·m 72 to 87 ft·lbs
-------------------	-------------	--

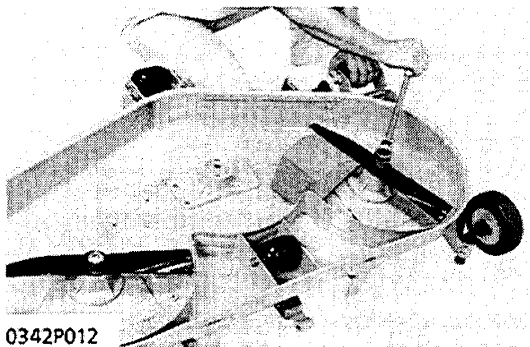

0342P012

Outer Blades

1. Loosen the blade screw.
2. Remove the blade screw, spline boss, 2-cup washers and blade.

Tightening torque	Blade screw	98 to 118 N·m 10 to 12 kgf·m 72 to 87 ft·lbs
-------------------	-------------	--

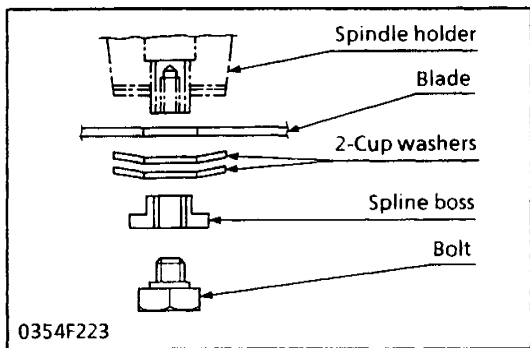

0354F223

NOTE

- To remove the blade securely, wedge a block of wood between one blade and the housing in such position that it will hold the blade safely while loosening or tightening the blade screw.

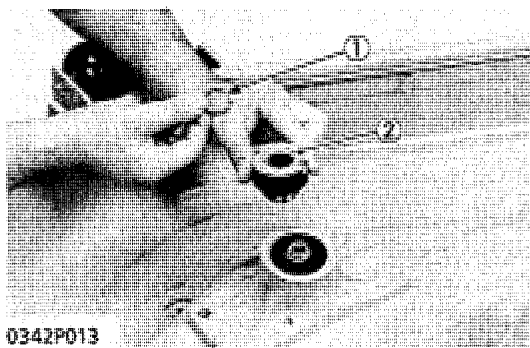

0342P013

Blade Boss

1. Remove the external snap ring (1).
2. Remove the blade boss (2).

(1) External Snap Ring

(2) Blade Boss

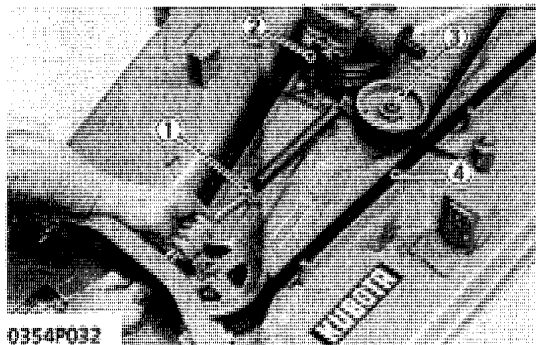

0354P032

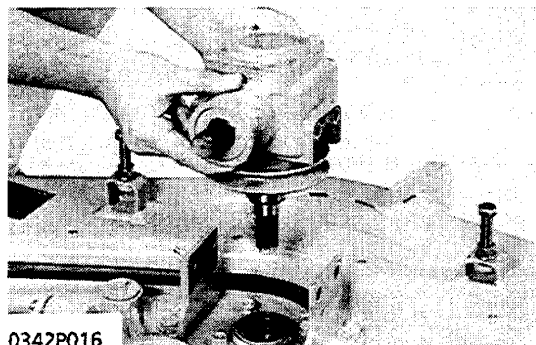

0342P016

Gear Box

1. Pull out the tension spring with a cord and remove it.
2. Remove the right hand gear box bracket and the V-belt (4).
3. Remove the screw of left gear box bracket (2).

- (1) Tension Spring Holder
- (2) Gear Box Bracket
- (3) Tension Pulley
- (4) V-belt

4. Pull out the gear box upward.
5. Loosen the drain plug.
6. Drain out gear oil.

Gear box oil	RC54-B RC60-B RC60-21B	0.40 ℓ 0.42 U.S. qts. 0.352 Imp. qts.
	RC72-B	0.75 ℓ 0.79 U.S. qts. 0.660 Imp. qts.

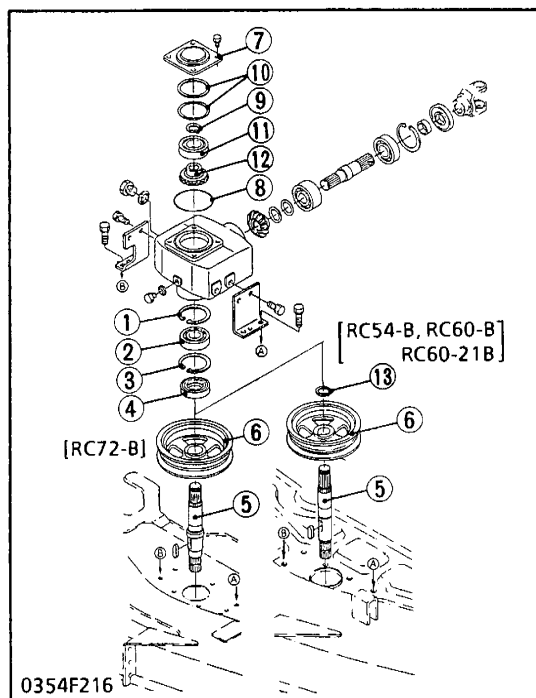

0354F216

Spindle Shaft

1. Remove the bevel case cover (7).
2. Remove the external snap ring (9) and shim (10).
3. Remove the ball bearing (11) and 15T bevel gear (12).
4. Tap out the bevel gear shaft (5) downward.

- (1) Internal Snap Ring
- (2) Ball Bearing
- (3) Internal Snap Ring
- (4) Oil Seal
- (5) Bevel Gear Shaft
- (6) Center Pulley
- (7) Bevel Case Cover
- (8) O-ring
- (9) External Snap Ring
- (10) Shim
- (11) Ball Bearing
- (12) 15T Bevel Gear
- (13) External Snap Ring (RC54-B, RC60-B, RC60-21B)

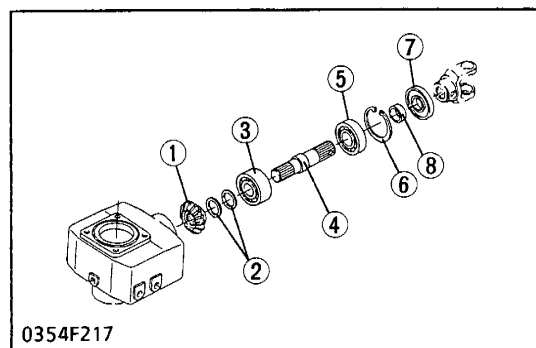

0354F217

Pinion Shaft

1. Remove the bevel gear (1) and shim (2).
2. Remove the oil seal (7) and internal snap ring (6).
3. Tap out the pinion shaft (4).

- (1) 22T Bevel Gear
- (2) Shim
- (3) Ball Bearing
- (4) Pinion Shaft
- (5) Ball Bearing
- (6) Internal Snap Ring
- (7) Oil Seal
- (8) Bush (only RC72-B)

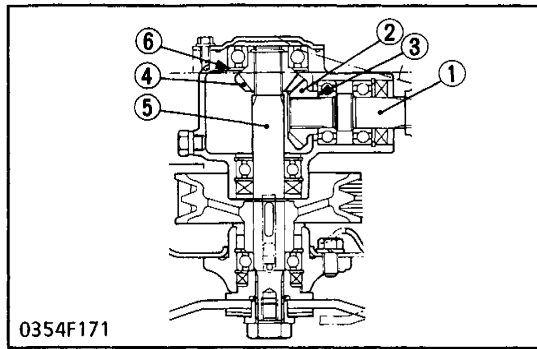

(When reassembling)

- Check the backlash, tooth contact and turning torque. If not proper, adjust with the shims (3), (6).

- (1) Pinion Shaft
- (2) 22T Bevel Gear
- (3) Shim
- (4) 15T Bevel Gear
- (5) Bevel Gear Shaft
- (6) Shim

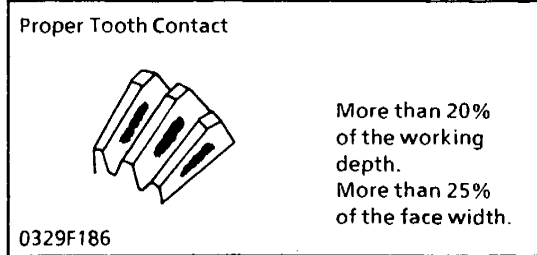

(Reference)

- Thickness of shims (3), (6): 0.1mm (0.004 in.)
0.3 mm (0.012 in.)

Backlash	Factory spec.	0.10 to 0.20 mm 0.0039 to 0.0079 in.
Turning torque	Factory spec.	Less than 0.69 N·m 0.07 kgf·m 0.51 ft·lbs

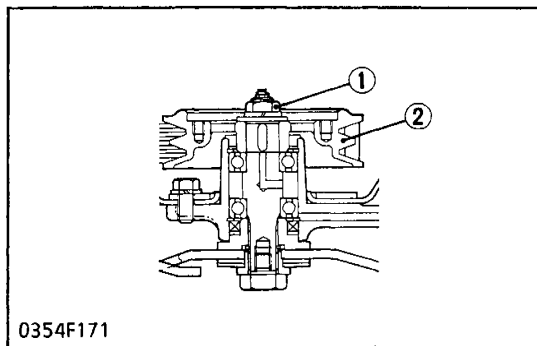

Outer Pulley and Pulley Holder

1. Remove the outer pulley mounting nuts (1) and the dual pulleys (2).
2. Remove the pulley holder mounting screws.
3. Separate the pulley holder from the deck.

Tightening torque	Outer pulley mounting nut	196 to 226 N·m 20 to 23 kgf·m 142 to 167 ft·lbs
	Pulley holder mounting screw	77.5 to 90.2 N·m 7.9 to 9.2 kgf·m 57.1 to 66.5 ft·lbs

- (1) Pulley Mounting Nut
- (2) Dual Pulley

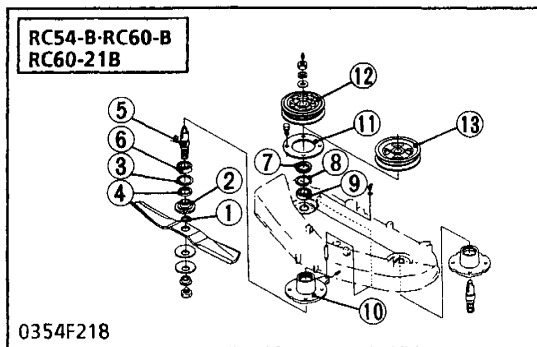

Blade Boss and Blade Shaft Ball Bearings

1. Remove the external snap ring (1).
2. Remove the blade boss (2).
3. Remove the internal snap ring (3) after removing the oil seal (4).
4. Remove the blade shaft (5) and ball bearing (6) downward.
5. Remove the oil seal (7), internal snap ring (8) and ball bearing (9) from the other side.

- (1) External Snap Ring
- (2) Blade Boss
- (3) Internal Snap Ring
- (4) Oil Seal
- (5) Blade Shaft
- (6) Ball Bearing
- (7) Oil Seal
- (8) Internal Snap Ring
- (9) Ball Bearing
- (10) Pulley Holder
- (11) Plate (except RC72-B)
- (12) Outer Dual Pulley (RH)
- (13) Outer Dual Pulley (LH)

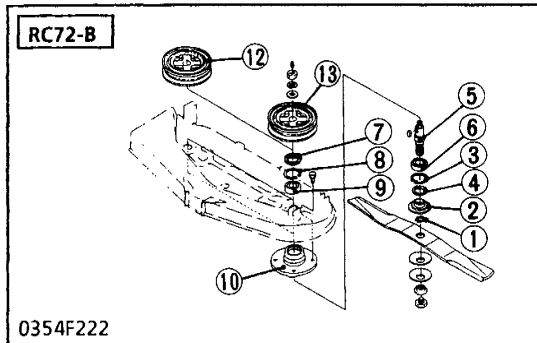

Kubota®

KUBOTA TRACTOR CORPORATION

CORPORATE OFFICE: 3401 DEL AMO BOULEVARD, TORRANCE, CA 90503
WESTERN DIVISION: 6665 Hardaway Road, Stockton, CA 95215 • (209) 931-5051
CENTRAL DIVISION: 14855 F.A.A. Blvd., Fort Worth, TX 76155 • (817) 571-0900
NORTHERN DIVISION: 2626 Port Road, Columbus, OH 43217 • (614) 492-1100
SOUTHEAST DIVISION: 1025 North Brook Parkway, Suwanee, GA 30174 • (770) 995-8855



PRINTED IN JAPAN
2003.07,S,AK,El,e
1998.08,S,AK,AK,e
REPRINTED IN U.S.A.
AUGUST 2003
Code No. 97897-10226

